



INSTALLATION INSTRUCTIONS

FTS24210		DRAG LINK KIT
1	FT50578	DRAG LINK
1	FT50705	TIE ROD END
1	FT50649	M29-1.5 RIGHT HAND THREAD JAM NUT
1	FT50650	M33-1.5 LEFT HAND THREAD JAM NUT
1	FT50651	HARDWARE SUBASSEMBLY

FT50651		HARDWARE SUBASSEMBLY
1	FT24210i	INSTRUCTIONS
1	FT50652	STEERING KNUCKLE INSERT
1	62000005152	5/8" USS FLAT WASHER
1	62000005081	5/8" SAE WASHER
1	FTAS12	STICKER FT BLUE 10X4
1	FTAS16	DRIVER WARNING DECAL
1	FTREGCARD	REGISTRATION CARD

2018-2023 JEEP WRANGLER(JL)/GLADIATOR(JT)

DRAG LINK KIT

FTS24210

NOTE: REFER TO OPTIONAL KIT BOX INSTRUCTIONS PRIOR TO INSTALLATION.

NOTE: TO ORDER WEARABLE REPLACEMENT COMPONENTS DO NOT USE PART NUMBERS SHOWN ON THIS INSTRUCTION SHEET. GO TO FABTECH WEBSITE AND LOOK UP WEARABLE REPLACEMENT PARTS TO FIND THE PROPER PART NUMBER TO ORDER.

Fabtech Motorsports | 12480 East End Ave. Chino, CA 91710

Tech Line: 909-597-7800 | Web: www.fabtechmotorsports.com

- TOOL LIST -

Required Tools (Not Included)

- Basic Hand Tools
- Floor Jack
- Jack Stands
- Torque Wrench
- Assorted Metric and S.A.E sockets, and Allen wrenches
- Die Grinder w/ Cutoff Wheel or Sawzall
- Drill
- 1" Drill Bit

- PRE-INSTALLATION NOTES -

For technical assistance call: **909-597-7800** or e-mail: **info@fabtechmotorsports.com**

READ THIS BEFORE YOU BEGIN INSTALLATION -

Check all parts to the parts list above before beginning installation. If any parts are missing contact Fabtech at 909-597-7800 and a replacement part will be sent to you immediately.

Read all instructions thoroughly from start to finish before beginning the installation. If these instructions are not properly followed severe frame, driveline and / or suspension damage may occur.

Check your local city and state laws prior to the installation of this system for legality. Do not install if not legal in your area.

Prior to the installation of this suspension system perform a front end alignment and record. Do not install this system if the vehicle alignment is not within factory specifications. Check for frame and suspension damage prior to installation.

The installation of this suspension system should be performed by two professional mechanics.

This suspension must be installed with Fabtech shock absorbers.

Use the provided thread locking compound on all hardware.

WARNING- Installation of this system will alter the center of gravity of the vehicle and may increase roll over as compared to stock.

Vehicles that receive oversized tires should check ball joints, uniballs, tie rods ends, pitman arm and idler arm every 2500-5000 miles for wear and replace as needed.

Verify differential fluid is at manufactures recommended level prior to kit installation. Installation of the kit will reposition the differential and the fill plug hole may be in a different position. (For example, if the manufacture recommends 3 quarts of fluid, make sure the diff has 3 quarts of fluid). Check your specific manual for correct amount of fluid.

FOOTNOTES -

-

- INSTRUCTIONS -

FRONT SUSPENSION

1. Jack up the front end of the vehicle and support the frame rails with jack stands. **NEVER WORK UNDER AN UNSUPPORTED VEHICLE!** Remove the front tires.
2. Completely remove the factory drag link from the vehicle. Then disconnect the center link from the passenger side knuckle only. **SEE FIGURE 1**

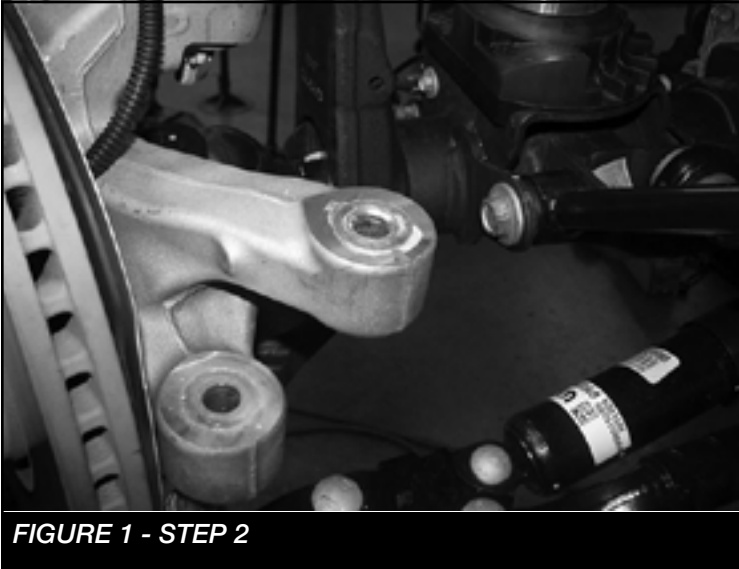

3. Using a 1" drill bit. Drill out the tapered hole on the knuckle where the factory drag link mounted. **SEE FIGURE 2-3**

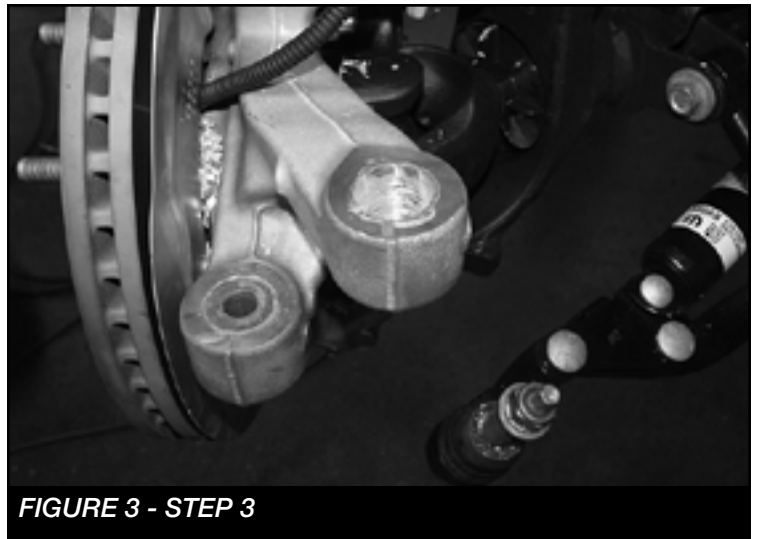
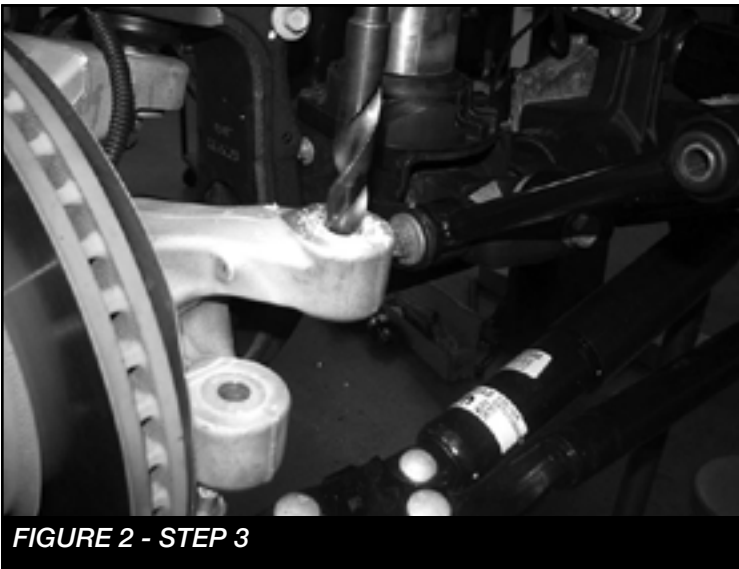

4. Insert the FT50652 (Steering Knuckle Insert) into the knuckle to check it fits correctly and is flush with the bottom side. **SEE FIGURE 4**



5. Locate the factory drag link. Loosen the adjuster and remove the rod end with the collar. **NOTE: There are two variances depending of the year of the vehicle. SEE FIGURE 5**

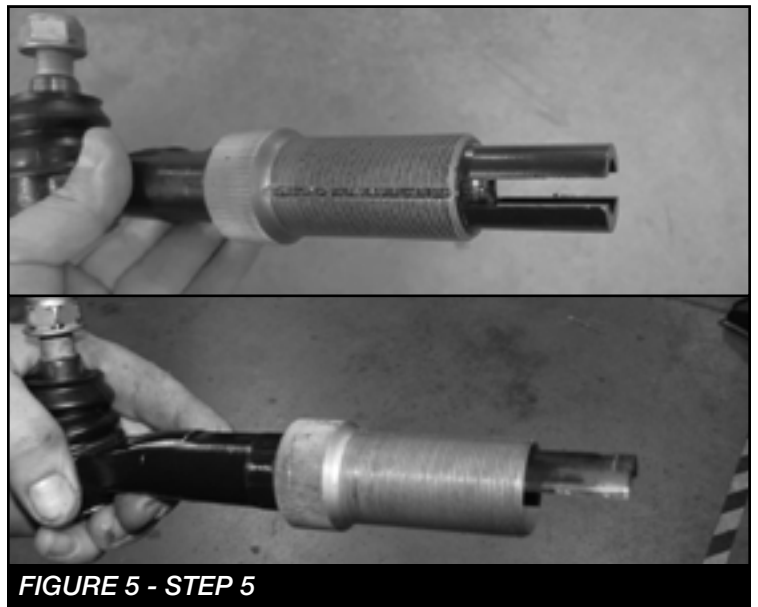

6. Remove the collar from the rod end. The ear on the threaded end will need to be cut off flush. **SEE FIGURE 6**



FIGURE 6 - STEP 6

7. Install the FT50650 (M33-1.5 Jam Nut) onto the factory adjuster. Next, install the adjuster into the FT50578 (Drag Link). **NOTE: When installing leave 3/8" space between the jam nut and the adjuster. This is a starting point, final adjustments will be made when alignment is made. SEE FIGURES 7-8**

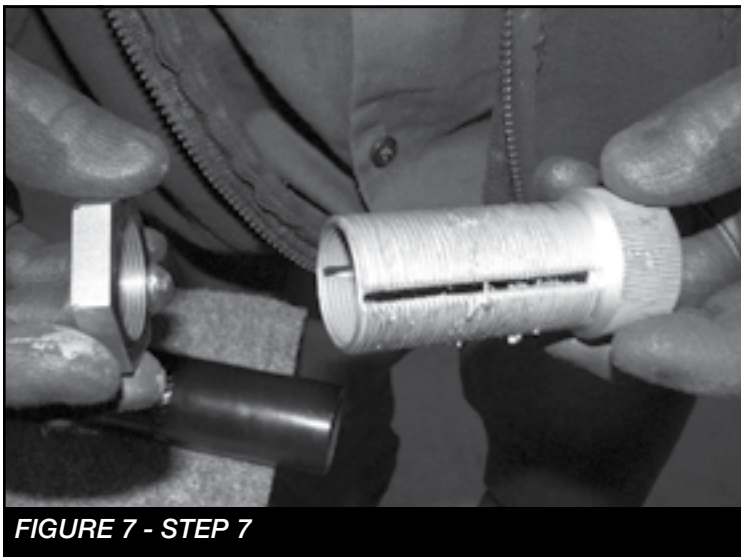

FIGURE 7 - STEP 7

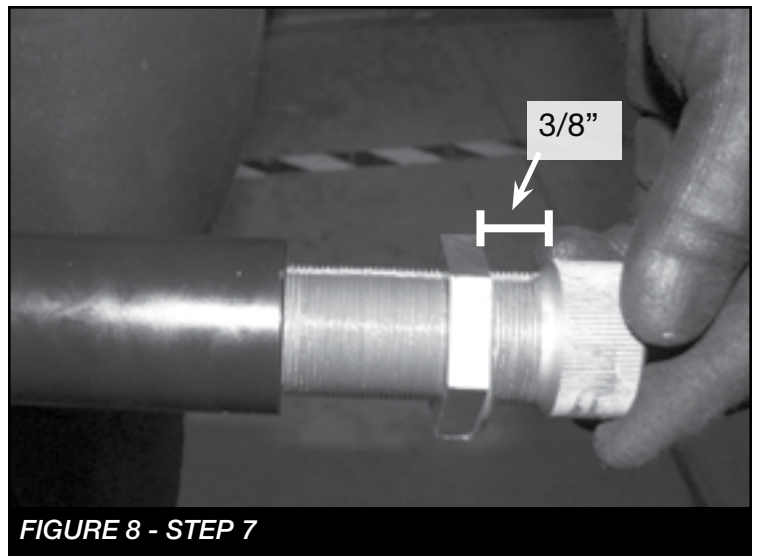

FIGURE 8 - STEP 7

8. Install FT50649 (M29-1.5 Jam Nut) onto the factory rod end. Next, install the rod end into the adjuster. **NOTE: When installing leave 3/8" space between the jam nut and the end of the thread on the rod end. This is a starting point, final adjustments will be made when alignment is made. SEE FIGURES 9-10 for installation and FIGURE 11 for final setup.**



FIGURE 9 - STEP 8

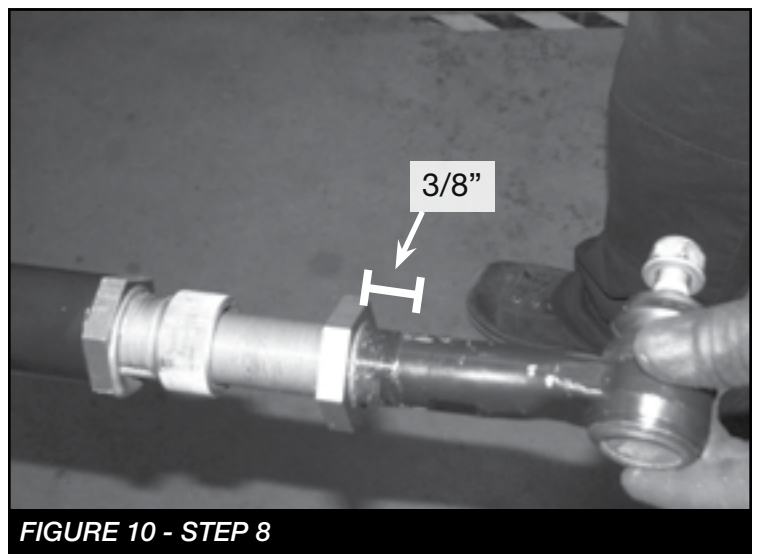

FIGURE 10 - STEP 8

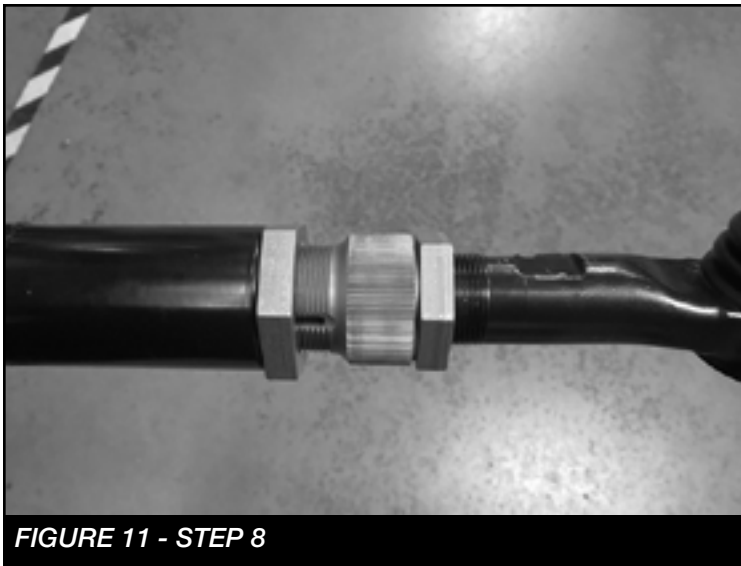

FIGURE 11 - STEP 8

9. Install the supplied Jam Nut on the FT50705 (Tie Rod End). **NOTE: When installing leave 1/2" space between the jam nut and the end of the thread on the rod end. This is a starting point, final adjustments will be made when alignment is made. SEE FIGURE 12.** Install the new rod end into the drag link.

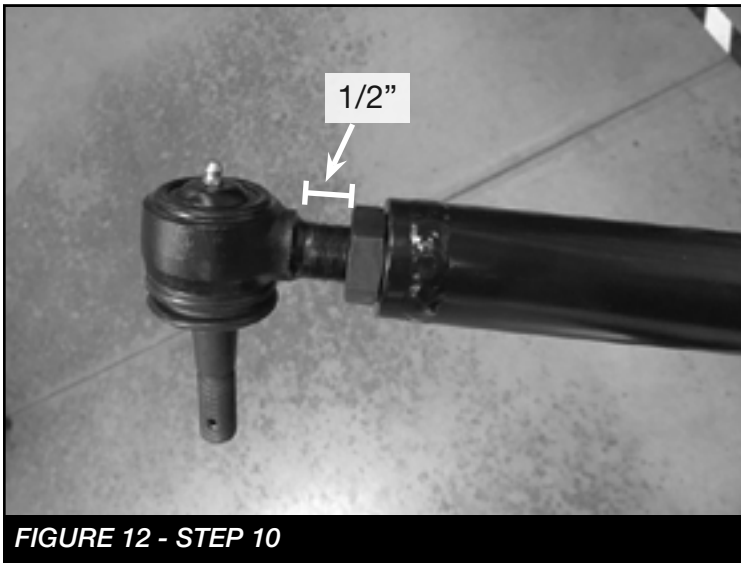

FIGURE 12 - STEP 10

10. Install the new drag link to the pitman arm and knuckle.

Torque to 43 ft-lbs. **NOTE:** The straight end with the factory rod end will attach to the pitman arm. **SEE FIGURE 14**

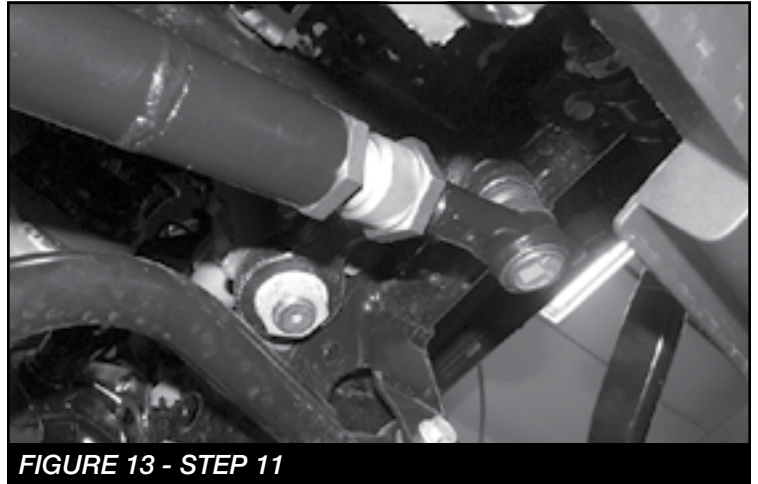

FIGURE 13 - STEP 11

11. Next, install the end with the new rod end to the knuckle like shown in **FIGURE 19** using the supplied 5/8" USS washer & 5/8" SAE washer on the bottom side. Torque to 43 ft-lbs then install cotter pin. **NOTE: Make sure the washer sits completely flush with the knuckle. Grind/sand accordingly for proper fit. SEE FIGURE 15**

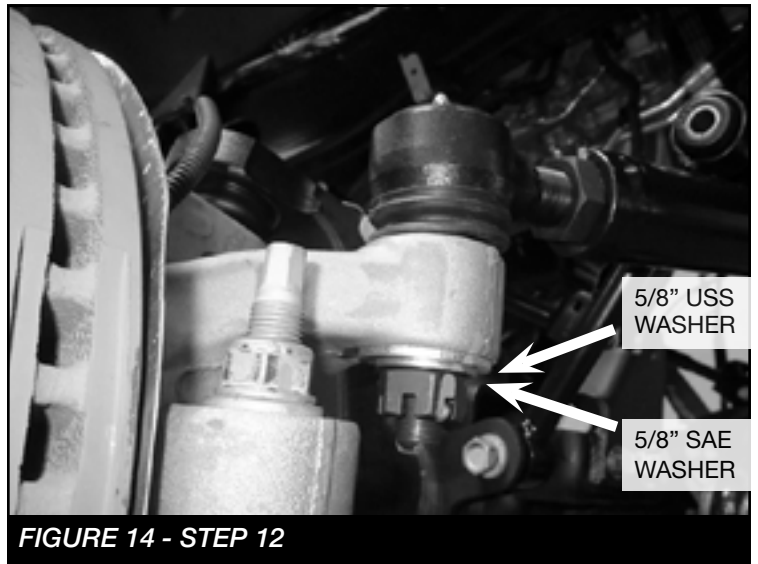

FIGURE 14 - STEP 12

12. Continue with the installation of optional kit boxes at this time.
13. Install Driver Warning Decal. Complete product registration card and mail to Fabtech in order to receive future safety and technical bulletins on this suspension.

Vehicles that will receive oversized tires should check ball joints, uniballs and all steering components every 2500-5000 miles for wear and replace as required.

RETORQUE ALL NUTS, BOLTS AND LUGS AFTER 50 MILES AND PERIODICALLY THEREAFTER.

For technical assistance call: **909-597-7800**

- Product Warranty and Warnings -

Fabtech provides a Limited Lifetime Warranty to the original retail purchaser who owns the vehicle, on which the product was originally installed, for defects in workmanship and materials.

The Limited Lifetime Warranty excludes the following Fabtech items; bushings, bump stops, ball joints, tie rod ends, limiting straps, cross shafts, heim joints and driveshafts. These parts are subject to wear and are not considered defective when worn. They are warranted for 60 days from the date of purchase for defects in workmanship.

Dirt Logic and Performance Coilover take apart shocks are considered a serviceable shock with a one year warranty on leakage only. Service seal kits are available separately for future maintenance. All other shocks are covered under our Limited Lifetime Warranty.

Fabtech does not warrant any product for finish, alterations, modifications and/or installation contrary to Fabtech's instructions. Alterations to the finish of the parts including but not limited to painting, powder coating, plating and/or welding will void all warranties. Some finish damage may occur to parts during shipping, which is considered normal and is not covered under warranty.

Fabtech products are not designed nor intended to be installed on vehicles used in race applications or for racing purposes or for similar activities. (A "RACE" is defined as any contest between two or more vehicles, or any contest of one or more vehicle against the clock, whether or not such contest is for a prize). This warranty does not include coverage for police or taxi vehicles, race vehicles, or vehicles used for government or commercial purposes. Also excluded from this warranty are sales outside of the United States of America.

Installation of most suspension products will raise the center of gravity of the vehicle and will cause the vehicle to handle differently than stock. It may increase the vehicle's susceptibility to a rollover, on road and off road, at all speeds. Extreme care should be taken to operate the vehicle safely at all times to prevent rollover or loss of control resulting in serious injury or death. Fabtech front end Desert Guards may impair the deployment or operation of vehicles equipped with supplemental restraining systems/air bag systems and should not be installed if the vehicle is equipped as so.

Fabtech makes every effort to ensure suspension product compatibility with all vehicles listed on the website, but due to unknown auto manufacturer's production changes and/or inconsistencies by the auto manufacturer, Fabtech cannot be responsible for 100% compatibility, including the fitment of tire and wheel sizes listed. The Tire and Wheel sizes listed in Fabtech's website are only a guideline for street driving with noted fender trimming. Fabtech is not responsible for damages to the vehicle's body or tires. Fabtech is not responsible for premature wear of factory components due to the installation of oversized tires and wheels.

Fabtech's obligation under this warranty is limited to the repair or replacement, at Fabtech option, of the defective product only. All costs of removal, installation or re-installation, freight charges, incidental or consequential damages are expressly excluded from this warranty. Fabtech is not responsible for damages and/or warranty of other vehicle parts related or non related to the installed Fabtech product. This warranty is expressly in lieu of all other warranties expressed or implied. This warranty shall not apply to any product that has been subject to accident, negligence, alteration, abuse or misuse as determined by Fabtech.

Fabtech suspension components must be installed as a complete system including shocks as shown on our website. All warranties will become void if Fabtech parts are combined and/or substituted with other aftermarket suspension products. Combination and/or substitution of other aftermarket suspension parts may cause premature wear and/or product failure resulting in an accident causing injury or death. Fabtech does not warrant products not manufactured by Fabtech.

Depending on the condition of the factory suspension components retained after the installation of a Fabtech suspension not all vehicles may have the same ride stance front to rear as described in the website. The blue color of suspension components shown in all Fabtech photographs are for display purposes only. Majority of all Fabtech components will be black specifically where noted with part numbers ending in BK.

Installation of Fabtech product may void the vehicles factory warranty; it is the consumer's responsibility to check with their local vehicle's dealer for warranty disposition before the installation of the product. Some state laws may prohibit modification of suspension to a vehicle in whole or in part. It is the responsibility of the installer and consumer to consult local laws prior to the installation of any Fabtech suspension product to comply with such written laws.

It is the responsibility of the distributor and/or the retailer to review all warranties and warnings of Fabtech products with the consumer prior to purchase.

Fabtech reserves the right to super cede, discontinue, change the design, finish, part number and/or application of parts when deemed necessary without written notice. Fabtech is not responsible for misprints or typographical errors within the website or price sheet. For the most recent Product Warranty and Warnings visit our website www.fabtechmotorsports.com



INSTALLATION INSTRUCTIONS

FTS24261		5" COIL KIT 4-DOOR GLADIATOR
1	FT50776	5" DUAL RATE COIL (DRIVER REAR)
1	FT50777	5" DUAL RATE COIL (PASS REAR)
1	FT50831	HARDWARE SUBASSEMBLY

FT50831		HARDWARE SUBASSEMBLY
1	FT24261i	INSTRUCTIONS
1	FTAS12	STICKER FT BLUE 10X4
1	FTAS16	DRIVER WARNING DECAL
1	FTREGCARD	REGISTRATION CARD

2020-2023 JEEP GLADIATOR (JT)

5" REAR COIL KITS

FT24261i

- TOOL LIST -

Required Tools (Not Included)

Basic Hand Tools
Floor Jack
Jack Stands
Assorted Metric and S.A.E sockets, and Allen wrenches
Torque Wrench

- PRE-INSTALLATION NOTES -

For technical assistance call: **909-597-7800** or e-mail: **info@fabtechmotorsports.com**

READ THIS BEFORE YOU BEGIN INSTALLATION -

Check all parts to the parts list above before beginning installation. If any parts are missing contact Fabtech at 909-597-7800 and a replacement part will be sent to you immediately.

Read all instructions thoroughly from start to finish before beginning the installation. If these instructions are not properly followed severe frame, driveline and / or suspension damage may occur.

Check your local city and state laws prior to the installation of this system for legality. Do not install if not legal in your area.

Prior to the installation of this suspension system perform a front end alignment and record. Do not install this system if the vehicle alignment is not within factory specifications. Check for frame and suspension damage prior to installation.

The installation of this suspension system should be performed by two professional mechanics.

This suspension must be installed with Fabtech shock absorbers.

Use the provided thread locking compound on all hardware.

WARNING- Installation of this system will alter the center of gravity of the vehicle and may increase roll over as compared to stock.

Vehicles that receive oversized tires should check ball joints, uniballs, tie rods ends, pitman arm and idler arm every 2500-5000 miles for wear and replace as needed.

Verify differential fluid is at manufactures recommended level prior to kit installation. Installation of the kit will reposition the differential and the fill plug hole may be in a different position. (For example, if the manufacture recommends 3 quarts of fluid, make sure the diff has 3 quarts of fluid). Check your specific manual for correct amount of fluid.

FOOTNOTES -

NOTE: REFER TO OPTIONAL KIT BOX INSTRUCTIONS PRIOR TO INSTALLATION.

- INSTRUCTIONS -

REAR SUSPENSION

1. Supporting the rear axle. Disconnect the brake lines from the frame and save hardware, Next, Disconnect the sway bar end links from the rear axle.
2. Remove the factory shocks and save hardware.
3. Carefully lower the axle and remove the factory springs. Save the rubber spring isolators.
4. Install the new Fabtech rear coil springs FT50776 (Driver Rear) & FT50777 (Pass Rear) using the factory rubber isolators. **SEE FIGURE 1**

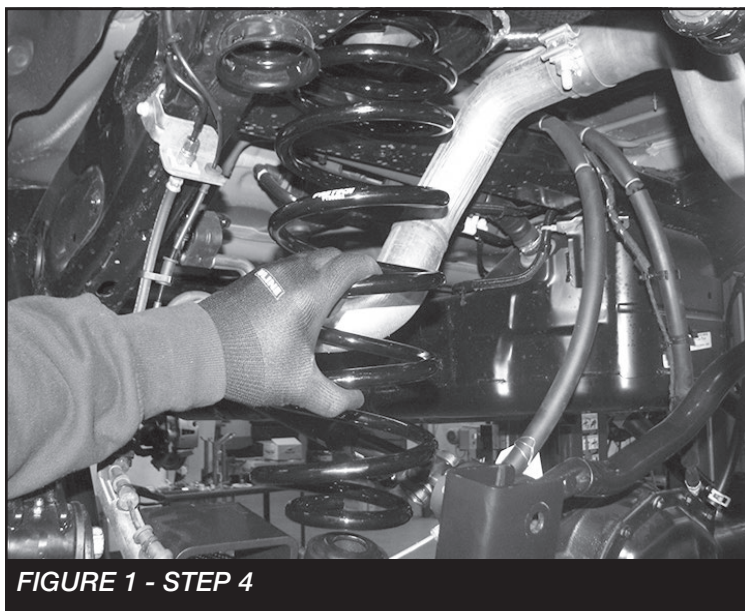

FIGURE 1 - STEP 4

5. Refer to the main box kit instructions for shock installation.
6. Install tires and wheels and torque lug nuts to wheel manufacturer's specifications. Turn front tires left to right and check for appropriate tire clearance. **Note - Some oversized tires may require trimming of the front bumper & valance.**
7. Check front end alignment and set to factory specifications. Readjust headlights.
8. Recheck all bolts for proper torque.
9. Recheck brake hoses, ABS wires and suspension parts for proper tire clearance while turning tires fully left to right.

10. Check the fluid in the front and rear differential and fill if needed with factory specification differential oil. **Note - some differentials may expel fluid after filling and driving. This can be normal in resetting the fluid level with the new position of the differential/s.**
11. Install Driver Warning Decal. Complete product registration card and mail to Fabtech in order to receive future safety and technical bulletins on this suspension.

Vehicles that will receive oversized tires should check ball joints, uniballs and all steering components every 2500-5000 miles for wear and replace as required.

RE-TORQUE ALL NUTS, BOLTS AND LUGS AFTER 50 MILES AND PERIODICALLY THEREAFTER.

For technical assistance call: **909-597-7800**

- Product Warranty and Warnings -

Fabtech provides a Limited Lifetime Warranty to the original retail purchaser who owns the vehicle, on which the product was originally installed, for defects in workmanship and materials.

The Limited Lifetime Warranty excludes the following Fabtech items; bushings, bump stops, ball joints, tie rod ends, limiting straps, cross shafts, heim joints and driveshafts. These parts are subject to wear and are not considered defective when worn. They are warranted for 60 days from the date of purchase for defects in workmanship.

Dirt Logic and Performance Coilover take apart shocks are considered a serviceable shock with a one year warranty on leakage only. Service seal kits are available separately for future maintenance. All other shocks are covered under our Limited Lifetime Warranty.

Fabtech does not warrant any product for finish, alterations, modifications and/or installation contrary to Fabtech's instructions. Alterations to the finish of the parts including but not limited to painting, powder coating, plating and/or welding will void all warranties. Some finish damage may occur to parts during shipping, which is considered normal and is not covered under warranty.

Fabtech products are not designed nor intended to be installed on vehicles used in race applications or for racing purposes or for similar activities. (A "RACE" is defined as any contest between two or more vehicles, or any contest of one or more vehicle against the clock, whether or not such contest is for a prize). This warranty does not include coverage for police or taxi vehicles, race vehicles, or vehicles used for government or commercial purposes. Also excluded from this warranty are sales outside of the United States of America.

Installation of most suspension products will raise the center of gravity of the vehicle and will cause the vehicle to handle differently than stock. It may increase the vehicle's susceptibility to a rollover, on road and off road, at all speeds. Extreme care should be taken to operate the vehicle safely at all times to prevent rollover or loss of control resulting in serious injury or death. Fabtech front end Desert Guards may impair the deployment or operation of vehicles equipped with supplemental restraining systems/air bag systems and should not be installed if the vehicle is equipped as so.

Fabtech makes every effort to ensure suspension product compatibility with all vehicles listed on the website, but due to unknown auto manufacturer's production changes and/or inconsistencies by the auto manufacturer, Fabtech cannot be responsible for 100% compatibility, including the fitment of tire and wheel sizes listed. The Tire and Wheel sizes listed in Fabtech's website are only a guideline for street driving with noted fender trimming. Fabtech is not responsible for damages to the vehicle's body or tires. Fabtech is not responsible for premature wear of factory components due to the installation of oversized tires and wheels.

Fabtech's obligation under this warranty is limited to the repair or replacement, at Fabtech option, of the defective product only. All costs of removal, installation or re-installation, freight charges, incidental or consequential damages are expressly excluded from this warranty. Fabtech is not responsible for damages and/or warranty of other vehicle parts related or non related to the installed Fabtech product. This warranty is expressly in lieu of all other warranties expressed or implied. This warranty shall not apply to any product that has been subject to accident, negligence, alteration, abuse or misuse as determined by Fabtech.

Fabtech suspension components must be installed as a complete system including shocks as shown on our website. All warranties will become void if Fabtech parts are combined and/or substituted with other aftermarket suspension products. Combination and/or substitution of other aftermarket suspension parts may cause premature wear and/or product failure resulting in an accident causing injury or death. Fabtech does not warrant products not manufactured by Fabtech.

Depending on the condition of the factory suspension components retained after the installation of a Fabtech suspension not all vehicles may have the same ride stance front to rear as described in the website. The blue color of suspension components shown in all Fabtech photographs are for display purposes only. Majority of all Fabtech components will be black specifically where noted with part numbers ending in BK.

Installation of Fabtech product may void the vehicles factory warranty; it is the consumer's responsibility to check with their local vehicle's dealer for warranty disposition before the installation of the product. Some state laws may prohibit modification of suspension to a vehicle in whole or in part. It is the responsibility of the installer and consumer to consult local laws prior to the installation of any Fabtech suspension product to comply with such written laws.

It is the responsibility of the distributor and/or the retailer to review all warranties and warnings of Fabtech products with the consumer prior to purchase.

Fabtech reserves the right to super cede, discontinue, change the design, finish, part number and/or application of parts when deemed necessary without written notice. Fabtech is not responsible for misprints or typographical errors within the website or price sheet. For the most recent Product Warranty and Warnings visit our website www.fabtechmotorsports.com

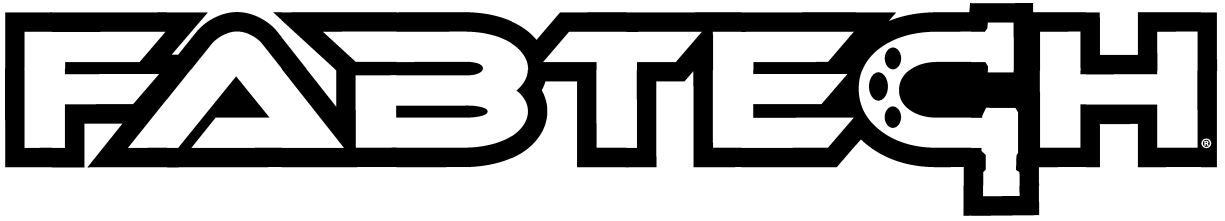

INSTALLATION INSTRUCTIONS

FTS24246		SHORT ARM LINK KIT LOWER F&R
1	FT50598	LOWER FRONT DRIVER LINK
1	FT50599	LOWER FRONT PASSENGER LINK
2	FT50771	LOWER REAR LINK
1	FT50757	HARDWARE SUBASSEMBLY

FT50757		HARDWARE SUBASSEMBLY
4	FT84	GREASE FITTING 1/4-28
8	FT50594	MISALIGNMENT 1" BEARING
8	FT1007	HALF BUSHING
4	FT615	SLEEVE 1.000 X .630 X .2.645
1	FT24246i	INSTRUCTIONS
1	FTLOCK	THREAD LOCKING COMPOUND
1	FTLUBE	URETHANE LUBE
1	FTAS12	STICKER FT BLUE 10X4 DIE CUT
1	FTAS16	DRIVER WARNING DECAL
1	FTREGCARD	REGISTRATION CARD

2020-2023 JEEP GLADIATOR JT SHORT ARM LOWER LINK KIT

FT24246i

- TOOL LIST -

Required Tools (Not Included)

Basic Hand Tools
Floor Jack
Jack Stands
Assorted Metric and S.A.E sockets, and Allen wrenches
Torque Wrench

- PRE-INSTALLATION NOTES -

NOTE: REFER TO OPTIONAL KIT BOX INSTRUCTIONS PRIOR TO INSTALLATION.

For technical assistance call: **909-597-7800** or e-mail: **info@fabtechmotorsports.com**

READ THIS BEFORE YOU BEGIN INSTALLATION -

Check all parts to the parts list above before beginning installation. If any parts are missing contact Fabtech at 909-597-7800 and a replacement part will be sent to you immediately.

Read all instructions thoroughly from start to finish before beginning the installation. If these instructions are not properly followed severe frame, driveline and / or suspension damage may occur.

Check your local city and state laws prior to the installation of this system for legality. Do not install if not legal in your area.

Prior to the installation of this suspension system perform a front end alignment and record. Do not install this system if the vehicle alignment is not within factory specifications. Check for frame and suspension damage prior to installation.

The installation of this suspension system should be performed by two professional mechanics.

This suspension must be installed with Fabtech shock absorbers.

Use the provided thread locking compound on all hardware.

WARNING- Installation of this system will alter the center of gravity of the vehicle and may increase roll over as compared to stock.

Vehicles that receive oversized tires should check ball joints, uniballs, tie rods ends, pitman arm and idler arm every 2500-5000 miles for wear and replace as needed.

Verify differential fluid is at manufactures recommended level prior to kit installation. Installation of the kit will reposition the differential and the fill plug hole may be in a different position. (For example, if the manufacture recommends 3 quarts of fluid, make sure the diff has 3 quarts of fluid). Check your specific manual for correct amount of fluid.

Periodically grease the bushings using a urethane compatible grease.

FOOTNOTES -

- Fits Gas Models Only
- For heavy offroad use, front driveshaft is required. Order FTS94057
- For heavy offroad use, rear driveshaft is required. See a quality driveline supplier to order

- INSTRUCTIONS -

FRONT SUSPENSION

1. Disconnect the negative terminal on the battery. Jack up the front end of the truck and support the frame rails with jack stands. **NEVER WORK UNDER AN UNSUPPORTED VEHICLE!** Remove the front tires.
2. With the axle supported, remove the driver side factory lower link and save hardware.
3. Locate the new Fabtech front lower links. Install the supplied bushings, sleeve and grease fitting into both links.
4. Install FT50598 (Driver lower link) using the supplied FT50594 (Misalignments) and factory hardware. Torque to 160 ft-lbs. **SEE FIGURE 1 FOR LINK IDENTIFICATION AND PRE-SET MEASUREMENTS. SEE FIGURES 2-3 FOR INSTALLATION.** From the center of the rod end to the center of the barrel should measure 24-1/8" on both front links.

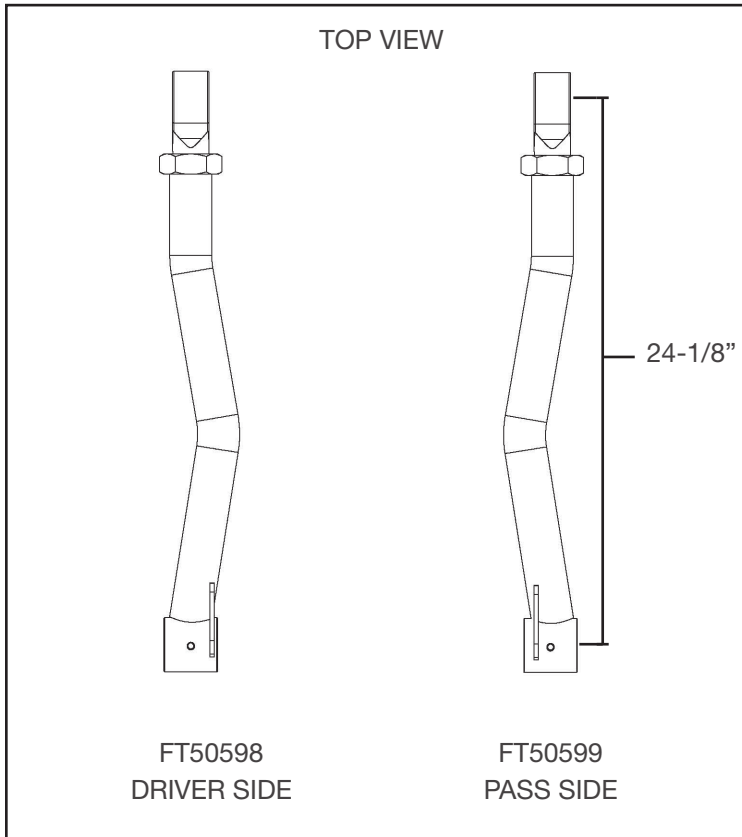
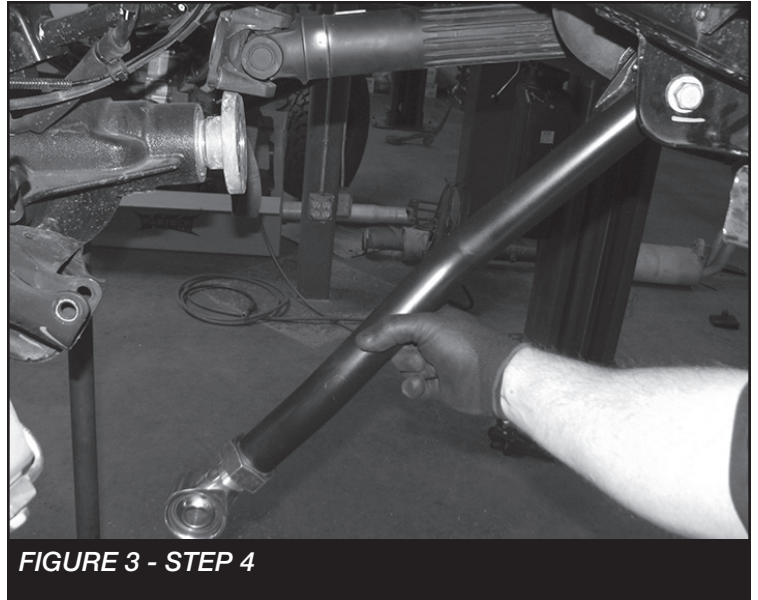
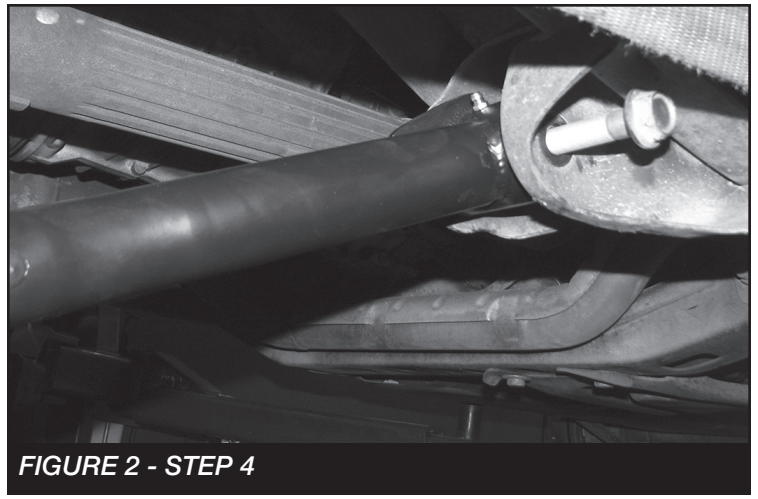

FIGURE 1 - STEP 4



5. Remove the passenger side lower link and save hardware.
 6. Repeat step 4 using FT50599 (Passenger lower link).
- **IF INSTALLING A FULL LIFT KIT CONTINUE WITH THE BOX KIT INSTRUCTIONS BEFORE CONTINUING WITH THE REAR LINK INSTALLATION.**

- REAR SUSPENSION -

7. Jack up the rear end of the truck and support the frame rails with jack stands. **NEVER WORK UNDER AN UNSUPPORTED VEHICLE!** Remove the rear tires.
8. With the axle supported, remove the driver side lower link and save hardware. **SEE FIGURE 4**

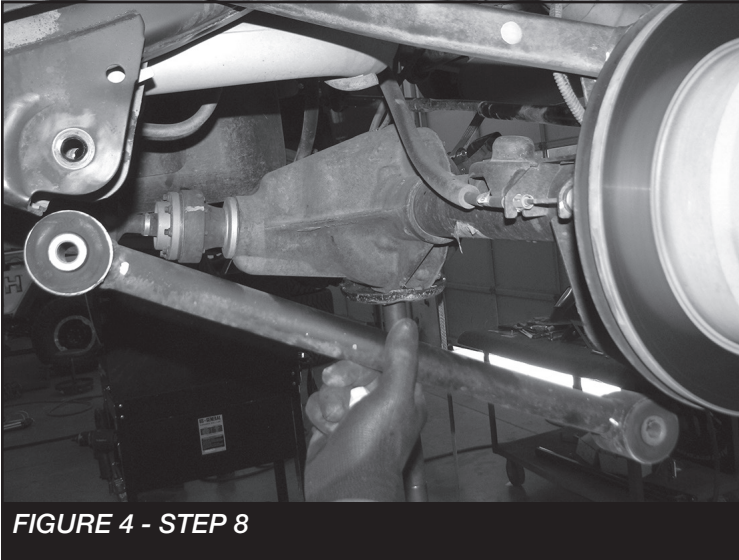

FIGURE 4 - STEP 8

9. Locate the (Rear lower links). Install the supplied bushings, sleeve and grease fitting into both links.
10. Install the new Fabtech lower link using the supplied FT50594 (Misalignments) and factory hardware like shown below. The joint end will mount on the frame side. Torque to 160 ft-lbs. **SEE FIGURE 5** Refer to diagram at the end of instructions for FT50771 preset measurements.

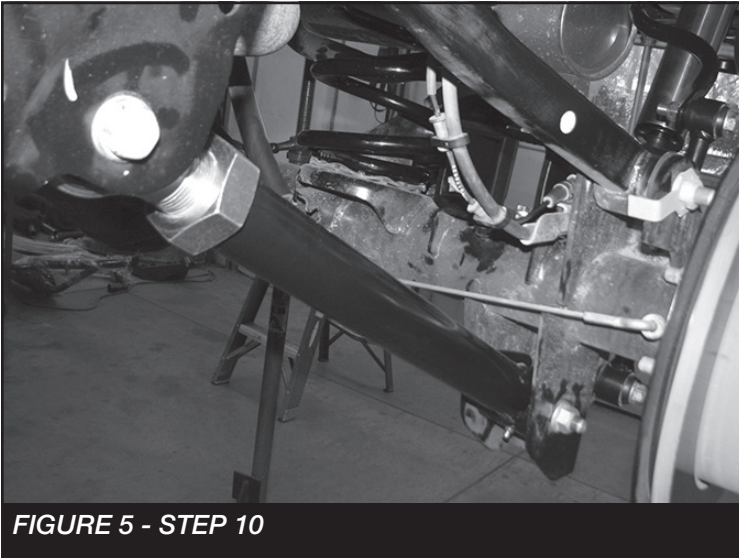

FIGURE 5 - STEP 10

11. Remove the passenger side lower link and save hardware.
12. Repeat step 10 on the passenger side.

13. Install tires and wheels and torque lug nuts to wheel manufacturer's specifications. Reconnect the negative battery cable. Turn front tires left to right and check for appropriate tire clearance. **Note - Some oversized tires may require trimming of the front bumper & valance.**
14. Check front end alignment and set to factory specifications. Readjust headlights.
15. Recheck brake hoses, ABS wires and suspension parts for proper tire clearance while turning tires fully left to right.
16. Check the fluid in the front and rear differential and fill if needed with factory specification differential oil. **Note - some differentials may expel fluid after filling and driving. This can be normal in resetting the fluid level with the new position of the differential/s.**
17. Install Driver Warning Decal. Complete product registration card and mail to Fabtech in order to receive future safety and technical bulletins on this suspension.

Vehicles that will receive oversized tires should check ball joints, uniballs and all steering components every 2500-5000 miles for wear and replace as required.

RE-TORQUE ALL NUTS, BOLTS AND LUGS AFTER 50 MILES AND PERIODICALLY THEREAFTER.

For technical assistance call: **909-597-7800**

Preset Measurements

From the center of the rod end to the center of the barrel should measure 23-3/4" on both rear links.

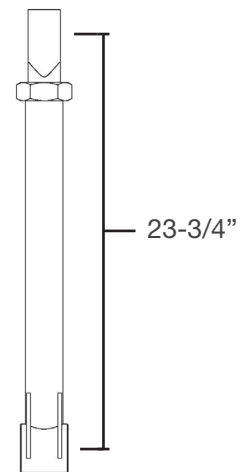

- Product Warranty and Warnings -

Fabtech provides a Limited Lifetime Warranty to the original retail purchaser who owns the vehicle, on which the product was originally installed, for defects in workmanship and materials.

The Limited Lifetime Warranty excludes the following Fabtech items; bushings, bump stops, ball joints, tie rod ends, limiting straps, cross shafts, heim joints and driveshafts. These parts are subject to wear and are not considered defective when worn. They are warranted for 60 days from the date of purchase for defects in workmanship.

Dirt Logic and Performance Coilover take apart shocks are considered a serviceable shock with a one year warranty on leakage only. Service seal kits are available separately for future maintenance. All other shocks are covered under our Limited Lifetime Warranty.

Fabtech does not warrant any product for finish, alterations, modifications and/or installation contrary to Fabtech's instructions. Alterations to the finish of the parts including but not limited to painting, powder coating, plating and/or welding will void all warranties. Some finish damage may occur to parts during shipping, which is considered normal and is not covered under warranty.

Fabtech products are not designed nor intended to be installed on vehicles used in race applications or for racing purposes or for similar activities. (A "RACE" is defined as any contest between two or more vehicles, or any contest of one or more vehicle against the clock, whether or not such contest is for a prize). This warranty does not include coverage for police or taxi vehicles, race vehicles, or vehicles used for government or commercial purposes. Also excluded from this warranty are sales outside of the United States of America.

Installation of most suspension products will raise the center of gravity of the vehicle and will cause the vehicle to handle differently than stock. It may increase the vehicle's susceptibility to a rollover, on road and off road, at all speeds. Extreme care should be taken to operate the vehicle safely at all times to prevent rollover or loss of control resulting in serious injury or death. Fabtech front end Desert Guards may impair the deployment or operation of vehicles equipped with supplemental restraining systems/air bag systems and should not be installed if the vehicle is equipped as so.

Fabtech makes every effort to ensure suspension product compatibility with all vehicles listed on the website, but due to unknown auto manufacturer's production changes and/or inconsistencies by the auto manufacturer, Fabtech cannot be responsible for 100% compatibility, including the fitment of tire and wheel sizes listed. The Tire and Wheel sizes listed in Fabtech's website are only a guideline for street driving with noted fender trimming. Fabtech is not responsible for damages to the vehicle's body or tires. Fabtech is not responsible for premature wear of factory components due to the installation of oversized tires and wheels.

Fabtech's obligation under this warranty is limited to the repair or replacement, at Fabtech option, of the defective product only. All costs of removal, installation or re-installation, freight charges, incidental or consequential damages are expressly excluded from this warranty. Fabtech is not responsible for damages and/or warranty of other vehicle parts related or non related to the installed Fabtech product. This warranty is expressly in lieu of all other warranties expressed or implied. This warranty shall not apply to any product that has been subject to accident, negligence, alteration, abuse or misuse as determined by Fabtech.

Fabtech suspension components must be installed as a complete system including shocks as shown on our website. All warranties will become void if Fabtech parts are combined and/or substituted with other aftermarket suspension products. Combination and/or substitution of other aftermarket suspension parts may cause premature wear and/or product failure resulting in an accident causing injury or death. Fabtech does not warrant products not manufactured by Fabtech.

Depending on the condition of the factory suspension components retained after the installation of a Fabtech suspension not all vehicles may have the same ride stance front to rear as described in the website. The blue color of suspension components shown in all Fabtech photographs are for display purposes only. Majority of all Fabtech components will be black specifically where noted with part numbers ending in BK.

Installation of Fabtech product may void the vehicles factory warranty; it is the consumer's responsibility to check with their local vehicle's dealer for warranty disposition before the installation of the product. Some state laws may prohibit modification of suspension to a vehicle in whole or in part. It is the responsibility of the installer and consumer to consult local laws prior to the installation of any Fabtech suspension product to comply with such written laws.

It is the responsibility of the distributor and/or the retailer to review all warranties and warnings of Fabtech products with the consumer prior to purchase.

Fabtech reserves the right to super cede, discontinue, change the design, finish, part number and/or application of parts when deemed necessary without written notice. Fabtech is not responsible for misprints or typographical errors within the website or price sheet. For the most recent Product Warranty and Warnings visit our website www.fabtechmotorsports.com



INSTALLATION INSTRUCTIONS

2020-2023 JEEP GLADIATOR (JT)

5" TRAIL KIT

FTS24255

NOTE: TO ORDER WEARABLE REPLACEMENT COMPONENTS DO NOT USE PART NUMBERS SHOWN ON THIS INSTRUCTION SHEET. GO TO FABTECH WEBSITE AND LOOK UP WEARABLE REPLACEMENT PARTS TO FIND THE PROPER PART NUMBER TO ORDER.

Fabtech Motorsports | 2213 Industrial Park Rd. Lancaster, SC 29720

Tech Line: 909-597-7800 | **Web:** www.fabtechmotorsports.com

FTS24255		5" TRAIL KIT
2	FT50261BK	SWAY BAR ENDLINK (FRONT)
2	FT1599-2-4	SWAY BAR ENDLINKS (REAR)
2	FT50644	FRONT BUMPSTOP SPACER
2	FT50769	REAR BUMPSTOP SPACER
1	FT50618	FRONT TRACK BAR BRACKET
1	FT50778	REAR TRACK BAR BRACKET
1	FT50619	LONG TRAVEL BRACKET (DRIVER)
1	FT50620	LONG TRAVEL BRACKET (PASS)
1	FT50782	HARDWARE SUBASSEMBLY
1	FT50781	HARDWARE KIT

FT50782		HARDWARE SUBASSEMBLY
8	FT1004	HALF BUSHING (REAR END LINK)
1	FT24255i	INSTRUCTIONS
12	FT404739	SLEEVE 12MM
1	FT50048	5/8 HOURGLASS BUSHING (FRONT END LINK)
2	FT50060	FRONT BUMPSTOP NUT TAB
2	FT50443	SLEEVE 1.000 X .500 X 1.550 (LOWER SHOCK)
2	FT50592	SLEEVE 1.000 X .563 X 1.400 (TRACK BAR)
4	FT50593	FRONT UPPER SHOCK SPACER (STEALTH ONLY)
1	FT50616	FRONT TRACK BAR NUT TAB
2	FT83105	LONG TRAVEL BRACKET NUT TAB
1	FTAS12	STICKER FT BLUE 10X4
1	FTAS16	DRIVER WARNING DECAL
1	FTLUBE	URETHANE LUBE PACKET
1	FTREGCARD	REGISTRATION CARD

FT50781 - HARDWARE KIT		LOCATION
6	M12-1.50 X 70MM HEX BOLT	SWAY BAR LINKS
6	12MM WASHER	
4	12MM LARGE OD WASHER	
4	M12-1.50 C-LOCK NUT	
2	1/2-13 X 3-1/2 HEX BOLT	FRONT BUMPSTOP
2	1/2" SPLIT LOCK WASHER	
2	9/16-12 X 3" HEX HEAD	F/R TRACK BAR
4	9/16 SAE WASHER	
2	C-LOCK NUT 9/16" -12	
4	5/16-18 X 1" HEX BOLT	REAR BUMPSTOP
8	5/16 SAE WASHER	
4	5/16-18 C-LOCK NUT	
2	1/2-13 X 4-1/2 HEX BOLT	LONG TRAVEL BRKT
4	1/2 SAE WASHER	
2	1/2-13 C-LOCK NUT	
6	3/8-16 X 1-1/4" HEX BOLT	LT BRKT/FRT TRACK
9	3/8" WASHER	
1	3/8" LOCK WASHER	
3	3/8-16 C-LOCK NUT	
2	5/16 SELF TAPPING BOLT	REAR BRAKE LINE
3	7/16-14 X 1" HEX BOLT	REAR TRACK BAR
6	7/16" SAE WASHER	
3	7/16-14 C-LOCK NUT	
1	THREAD LOCKING COMPOUND 1 MIL	

NOTE: REFER TO OPTIONAL KIT BOX INSTRUCTIONS PRIOR TO INSTALLATION.

- TOOL LIST -

Required Tools (Not Included)

- Basic Hand Tools
- Floor Jack
- Jack Stands
- Assorted Metric and S.A.E sockets, and Allen wrenches
- Torque Wrench
- Die Grinder w/ Cutoff Wheel or Sawzall

- PRE-INSTALLATION NOTES -

For technical assistance call: **909-597-7800** or e-mail: **info@fabtechmotorsports.com**

READ THIS BEFORE YOU BEGIN INSTALLATION -

Check all parts to the parts list above before beginning installation. If any parts are missing contact Fabtech at 909-597-7800 and a replacement part will be sent to you immediately.

Read all instructions thoroughly from start to finish before beginning the installation. If these instructions are not properly followed severe frame, driveline and / or suspension damage may occur.

Check your local city and state laws prior to the installation of this system for legality. Do not install if not legal in your area.

Prior to the installation of this suspension system perform a front end alignment and record. Do not install this system if the vehicle alignment is not within factory specifications. Check for frame and suspension damage prior to installation.

The installation of this suspension system should be performed by two professional mechanics.

This suspension must be installed with Fabtech shock absorbers.

Use the provided thread locking compound on all hardware.

WARNING- Installation of this system will alter the center of gravity of the vehicle and may increase roll over as compared to stock.

Vehicles that receive oversized tires should check ball joints, uniballs, tie rods ends, pitman arm and idler arm every 2500-5000 miles for wear and replace as needed.

Verify differential fluid is at manufactures recommended level prior to kit installation. Installation of the kit will reposition the differential and the fill plug hole may be in a different position. (For example, if the manufacture recommends 3 quarts of fluid, make sure the diff has 3 quarts of fluid). Check your specific manual for correct amount of fluid.

NOTICE SPRING BOW MAY OCCUR

Some Jeeps may have a pronounced bow in the stock front coil springs and /or after the installation of Fabtech coil springs. This is an inherent trait of the Jeep JL & JT front suspension. Many Jeeps come from the factory with bowed front springs while other Jeeps do not have a bow. There is a variance in the angles of the upper coil spring bucket and the lower coil spring axle mount. Depending on these variances it may cause springs to bow. Fabtech offers a coil correction kit as an option to help straighten the front coil springs should there be interference with other suspension parts as it cycles. Order FTS24280 Coil Correction Kit.

FOOTNOTES -

- Fits 6 CYL. models only.
- Fits gas models only.
- For heavy offroad use, front driveshaft is required. Order FTS94057
- For heavy offroad use, rear driveshaft is required. See a quality driveline supplier to order

- INSTRUCTIONS -

FRONT SUSPENSION

NOTE: REFER TO OPTIONAL KIT BOX INSTRUCTIONS PRIOR TO INSTALLATION.

1. Disconnect the negative terminal on the battery. Jack up the front end of the vehicle and support the frame rails with jack stands. **NEVER WORK UNDER AN UNSUPPORTED VEHICLE!** Remove the front tires.
2. On both the Driver and Passenger side, unbolt the front brake line brackets from the frame and the link arm. Save all hardware. **SEE FIGURES 1-2** On the driver side unclip the differential breather hose from the upper coil spring mount. **SEE FIGURE 3**

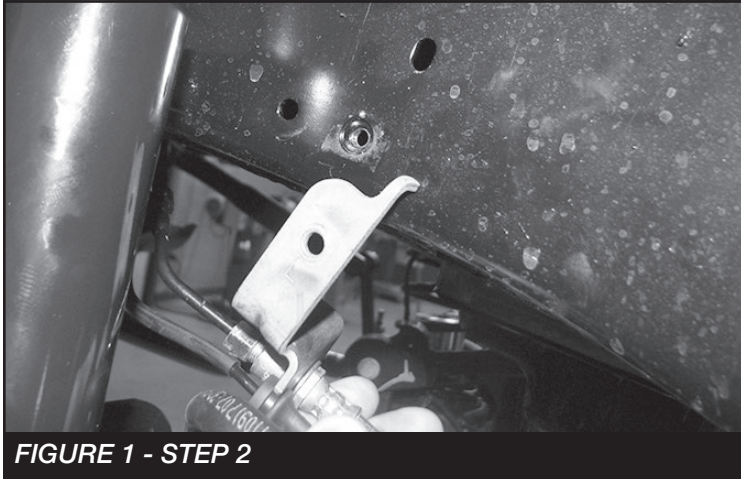

FIGURE 1 - STEP 2

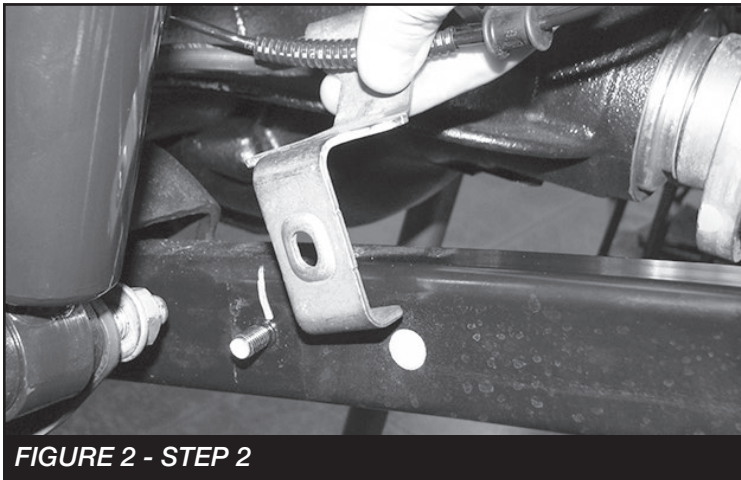

FIGURE 2 - STEP 2

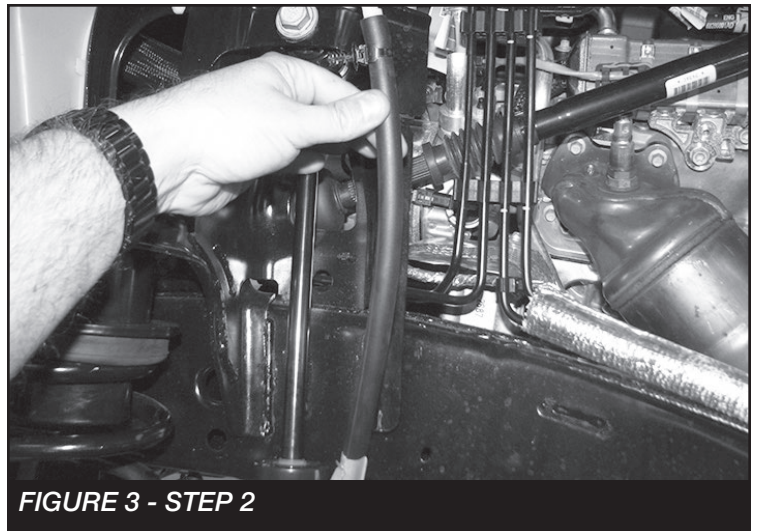

FIGURE 3 - STEP 2

3. Unbolt and remove both driver and passenger side brake line brackets from the axle spring perch. **SEE FIGURE 4**

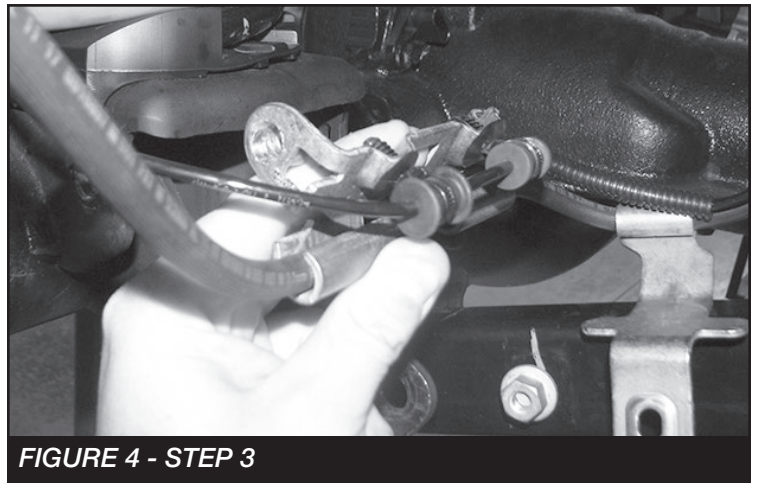

FIGURE 4 - STEP 3

4. Unplug the front diff locker harnesses from the axle **(RUBICON MODELS ONLY)** SEE FIGURES 5-6

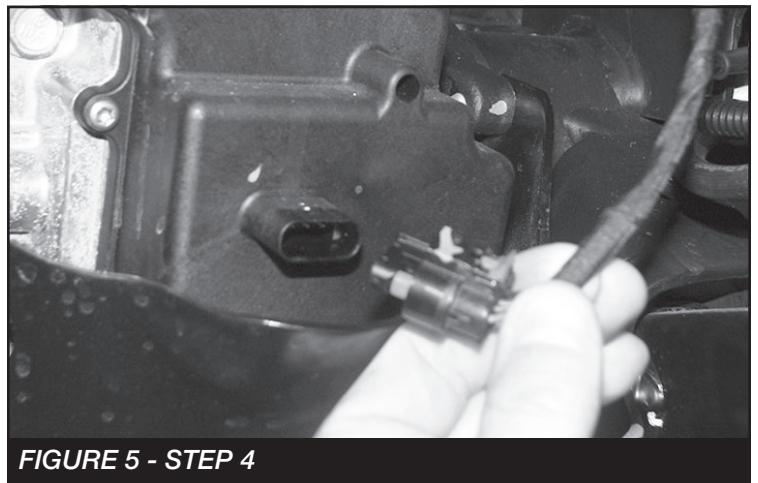

FIGURE 5 - STEP 4

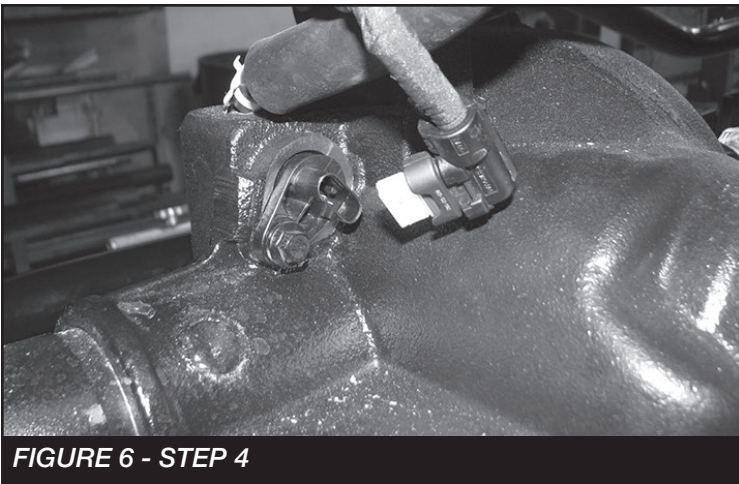

FIGURE 6 - STEP 4

5. Remove and discard the factory sway bar endlinks, save the hardware.
6. With the axle supported, remove the factory shocks. Save all hardware. Lower the front axle and remove the factory coil springs. Retain coil spring isolators.
7. If installing FTS24246 Lower link arms, do so now with the instructions provided in the kit box.
8. Disconnect the front track bar at the axle. Save hardware.
9. Install FT50618 (Front track bar bracket) to the factory mount using stock bolt. **SEE FIGURE 7.** Mark the 2 holes to drill using the new bracket as a guide. Remove and drill the holes to 3/8"

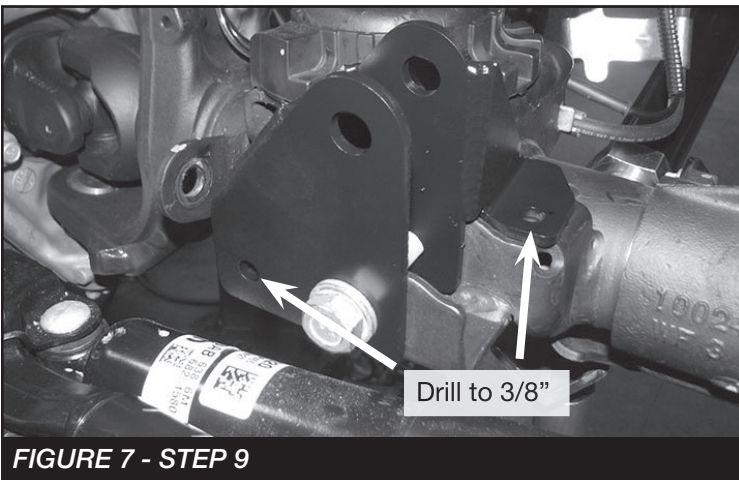

FIGURE 7 - STEP 9

10. Reinstall the bracket using the factory bolt and (2) supplied 3/8" x 1-1/4" bolts and hardware. **NOTE: Install the FT50592 (Sleeve) with the factory bolt between the new track bar bracket and the FT50616 (3/8" Nuttab) by inserting through the opening under the factory bracket for the rear vertical pad location. SEE FIGURE 8-9**

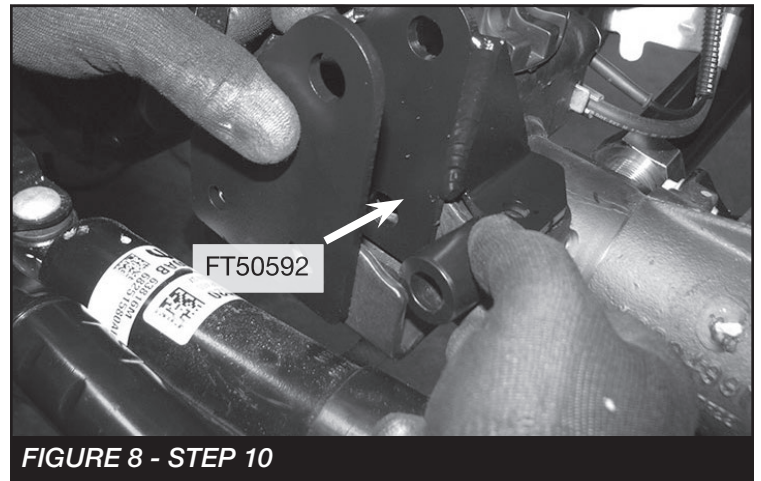

FIGURE 8 - STEP 10

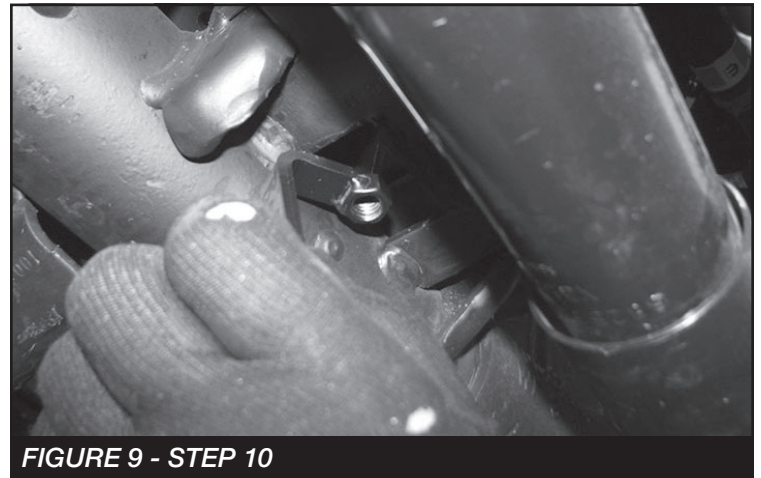

FIGURE 9 - STEP 10

11. If installing FTS24210 Drag Link Kit, do so now with the instructions provided in the kit box.

12. On the factory coil spring perch. Use a drill with a 1/2" drill bit and drill out the existing factory hole on both driver & passenger sides. **SEE FIGURE 10**

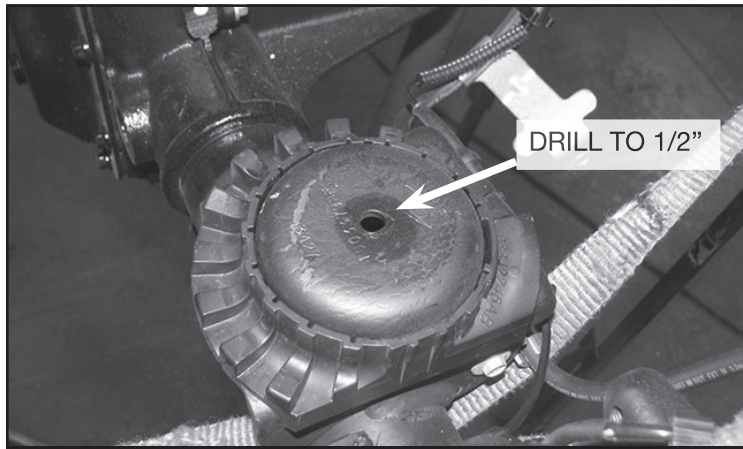

FIGURE 10 - STEP 12

13. **DRIVER SIDE:** Insert a 1/2" x 3-1/2" bolt and lock washer inside the FT50644 (Front bumpstop spacer). Place the FT50164 (Bumpstop spacer) into the bottom of FT50600 (Front driver spring) then install the spring into the vehicle as one unit. **NOTE: The driveshaft may have to be disconnected to install the spring back into the vehicle.** Once installed insert the FT50060 (Nut tab) through the opening on the spring perch and thread the 1/2" bolt. Torque to 127 ft-lbs. **SEE FIGURES 11-13** Repeat on passenger side

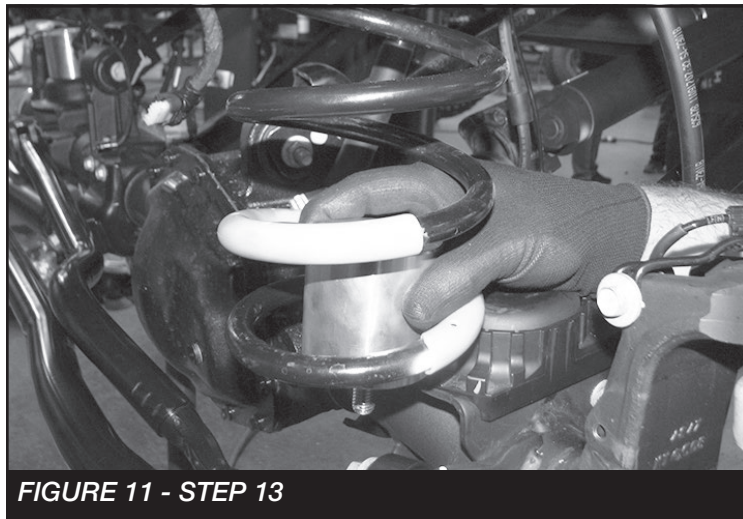

FIGURE 11 - STEP 13

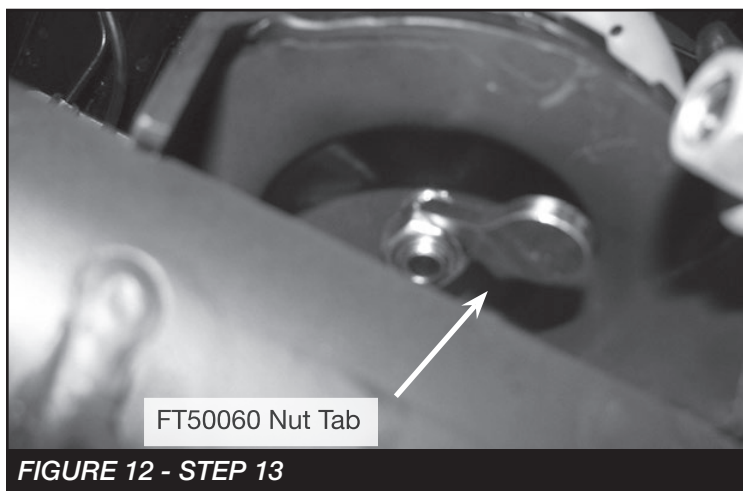

FIGURE 12 - STEP 13

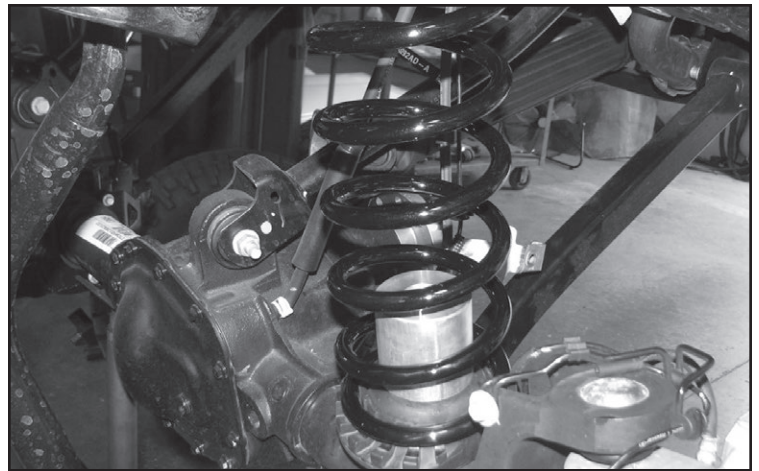

FIGURE 13 - STEP 13

14. Locate the hole on the lower coil mount where the factory brake line bracket mounts. Drill out the hole and welded nut on the backside to 3/8". Repeat on passenger side. **SEE FIGURE 14**



FIGURE 14 - STEP 14

15. Locate FT50619 (Lower driver shock bracket). Loosely install using the supplied 3/8" x 1-1/4" bolt, washer and FT83105 (Nuttap). Using the new bracket as a guide, mark the bottom hole on the lower shock bracket. Remove and drill to 3/8". **SEE FIGURE 15**

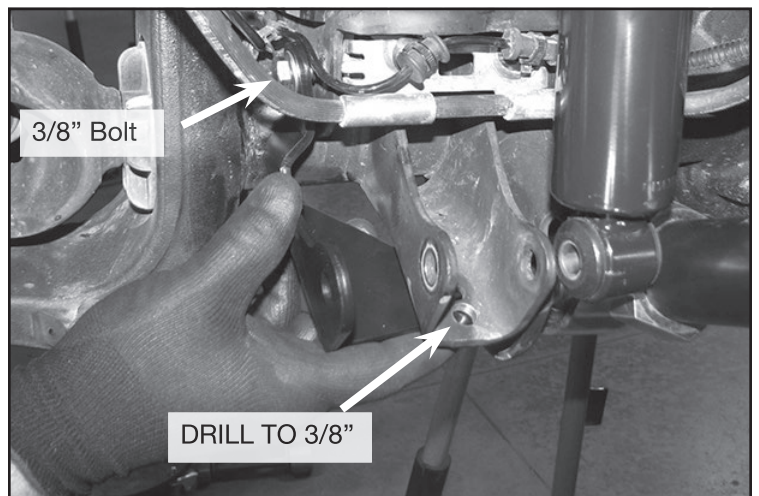
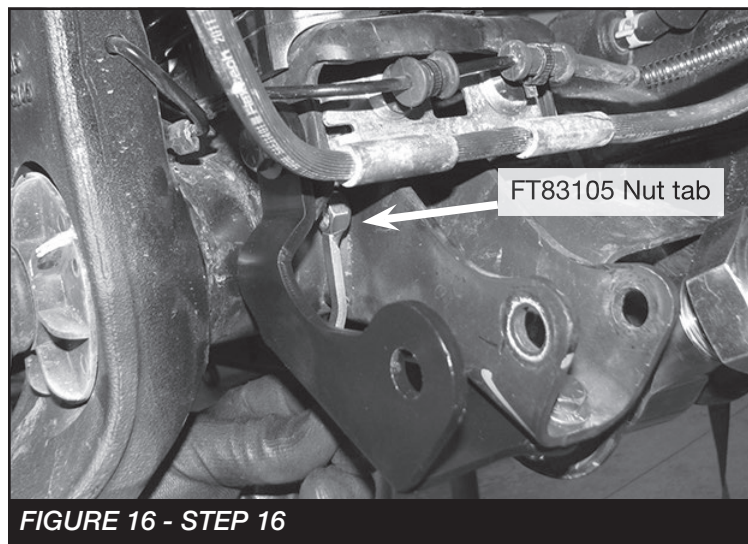
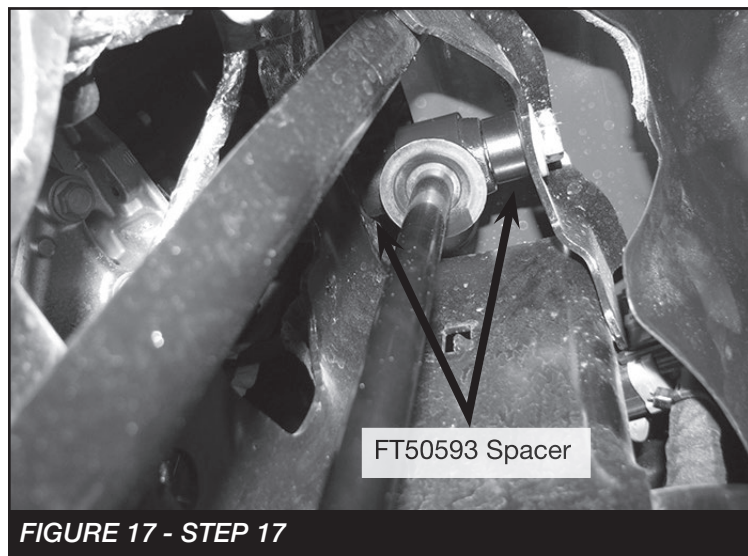

FIGURE 15 - STEP 15

16. Install the new bracket using the 3/8" hardware and FT83105 (Nut tab). Torque to 31 ft-lbs. **NOTE: Install the lower brake line bracket back into the factory location. The new 3/8" bolt and nut tab will secure it. SEE FIGURE 16**



17. **(Upper Shock Mount)** Locate FTS6354 (Stealth Shock) and install FT404739 (Sleeve) into each bushing. Next, Install the shock using (2) FT50593 (Spacer) on each side of the bushing using the factory hardware. **NOTE: If installing Dirt Logic shocks use the instructions provided in those boxes.** Torque to 100 ft-lbs. **SEE FIGURE 17**



18. **(Lower Shock Mount)** Install the shock to the lower mount using the supplied 1/2" X 4-1/2" bolt and hardware as well as the FT50443 (Spacer) in the factory location. Torque to 106 ft-lbs. **SEE FIGURE 18**

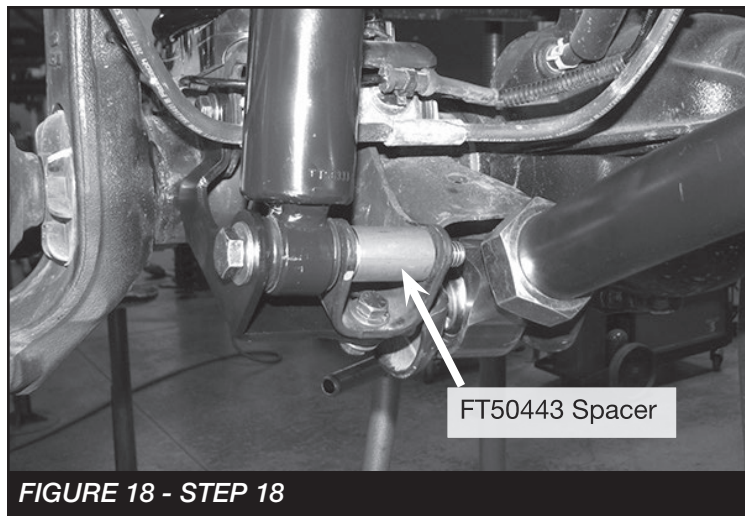

19. Re-install the track bar using the supplied 9/16" X 3" bolt, nut and washers. Torque to 153 ft-lbs. **SEE FIGURE 19**

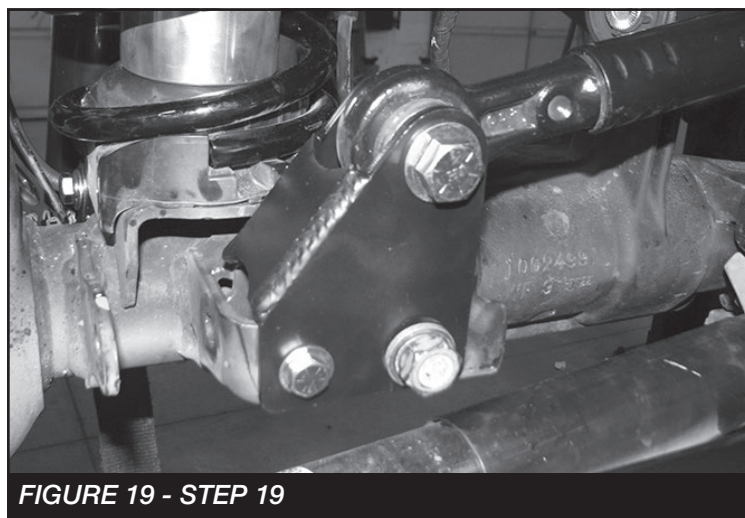

20. Install FT50048 (Bushings) and FT404739 (Sleeves) into FT50261BK (Sway bar links). Then, install the links to the axle mount and sway bar using the supplied M12 x 70mm hardware for the upper location and the factory for the lower. Torque to 65 ft-lbs. **SEE FIGURE 20**

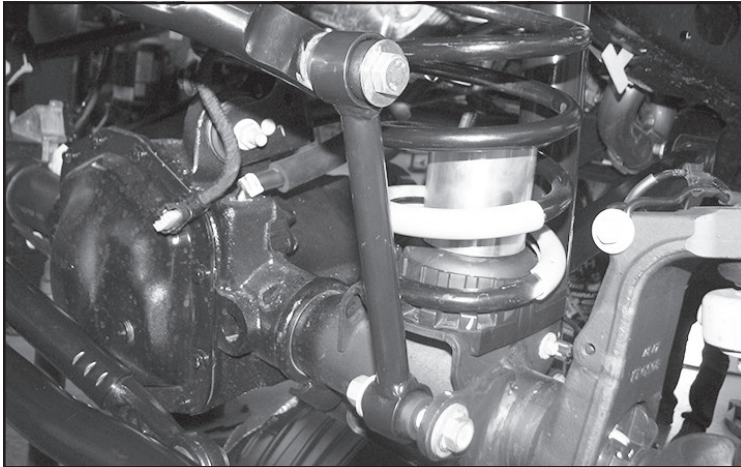

FIGURE 20 - STEP 20

21. Locate the factory brake line bracket on the front hydraulic brake line. This will need to be removed. Do so by cutting a small relief, then bend open. **NOTE: Use caution not to cut the brake line!** **SEE FIGURES 21-22**

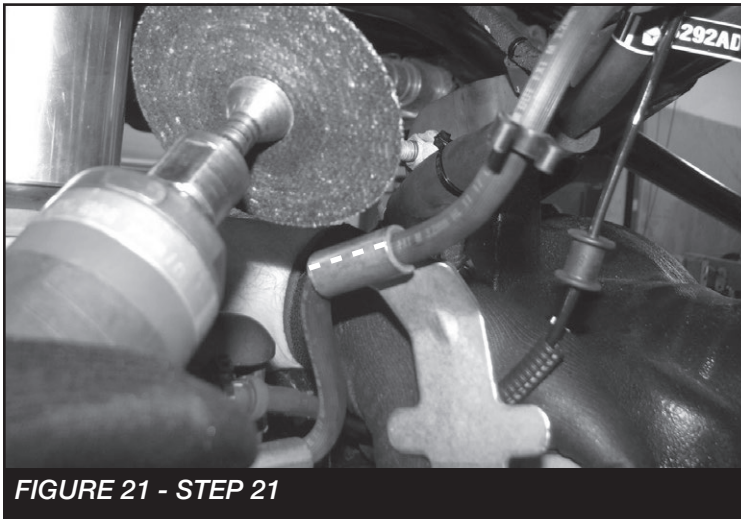

FIGURE 21 - STEP 21

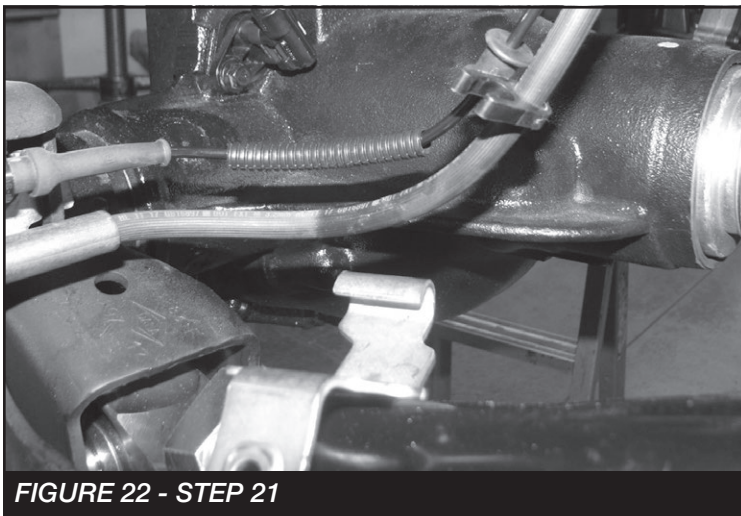

FIGURE 22 - STEP 21

22. Reinstall the diff breather hose by moving the metal clip up the hose 2" **SEE FIGURE 23** and the christmas tree fastener into the next hole down. **SEE FIGURE 24.**

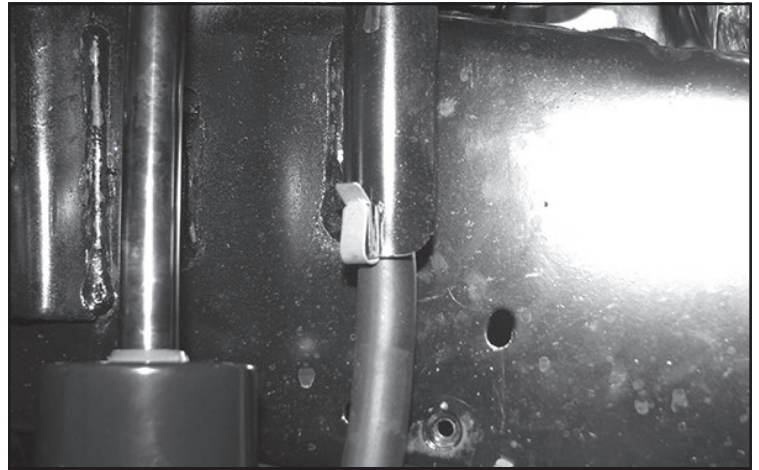

FIGURE 23 - STEP 22

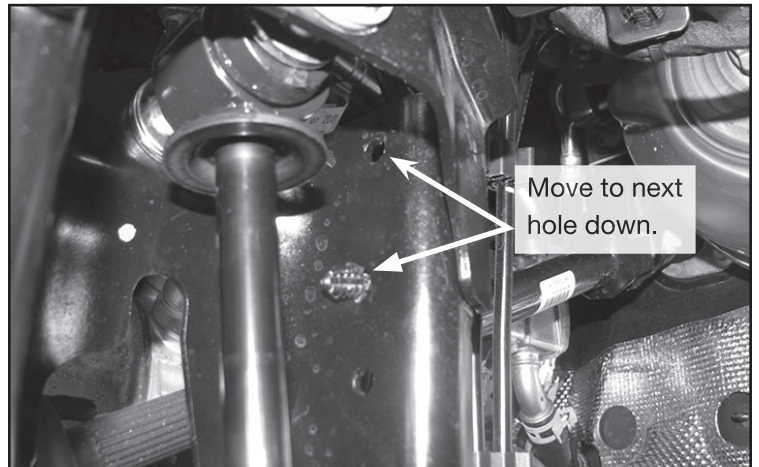

FIGURE 24 - STEP 22

23. **RUBICON MODELS ONLY:** Reinstall the electrical connectors at the diff.

- REAR SUSPENSION -

24. Jack up the rear end of the vehicle and support the frame rails with jack stands. **NEVER WORK UNDER AN UNSUPPORTED VEHICLE!** Remove the rear tires. Support the rear axle; do not allow axle to hang freely.
25. Remove the rear sway bar endlinks then remove the rear shocks and coil springs. Mark the driver and passenger coil springs for reinstallation. Save hardware. Disconnect the rear track bar from the axle bracket. Save hardware.
26. Disconnect the brake line bracket from the frame. Mark and cut off the locator tab and corner of the bracket like shown in **FIGURES 25-26**

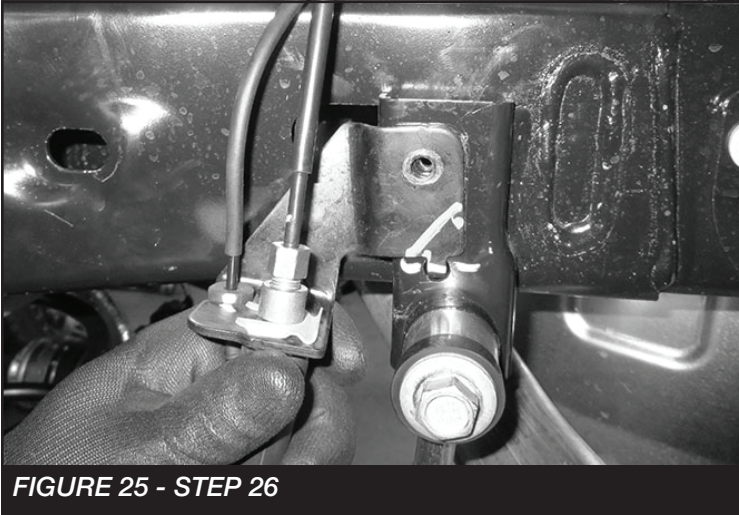

FIGURE 25 - STEP 26

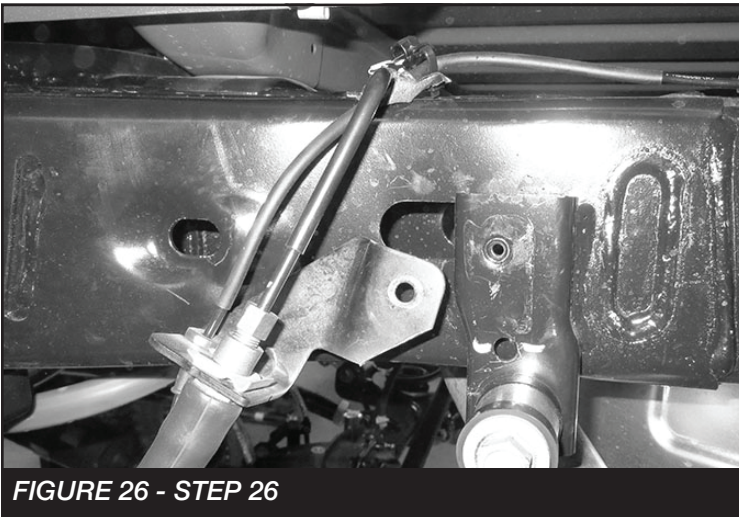

FIGURE 26 - STEP 26

27. Install the new rear bumpstop brackets using the supplied 5/16" x 1" hardware and the factory holes on the bumpstop pad. Torque to 17 ft-lbs. **SEE FIGURES 27-28**

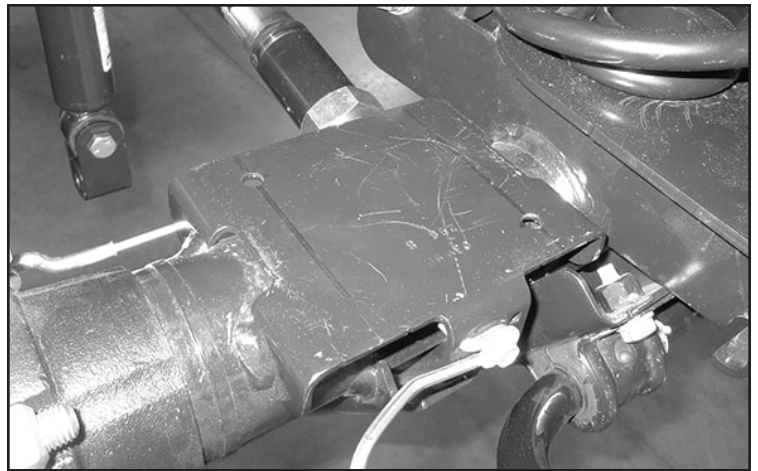

FIGURE 27 - STEP 27

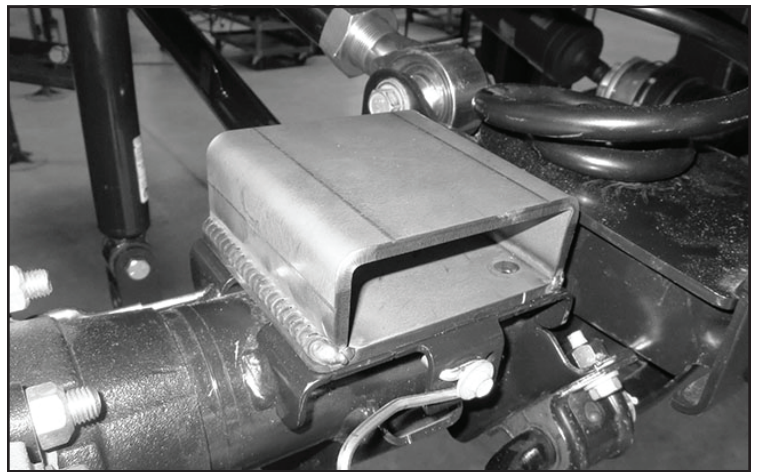

FIGURE 28 - STEP 27

28. Continue with the installation of the lower links at this time using the supplied instructions with that kit.

29. Locate the factory rear track bar bracket. Mark a straight line on the front and back before the 90 degree bend. Remove the track bar from the axle bracket and cut the top section off. **SEE FIGURES 29-30**

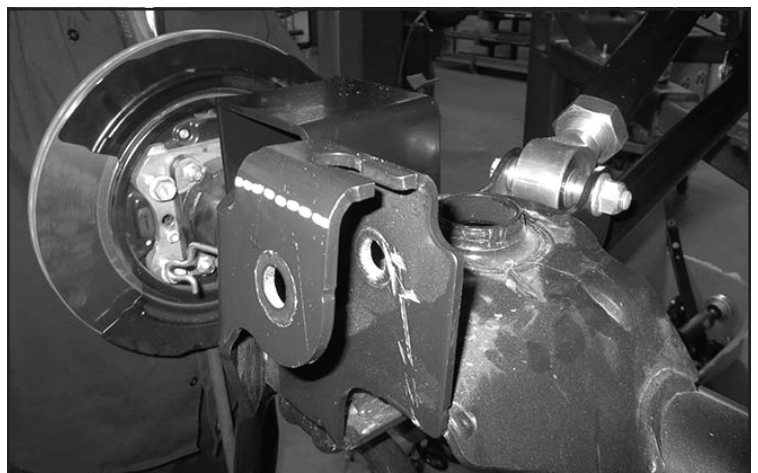

FIGURE 29 - STEP 29

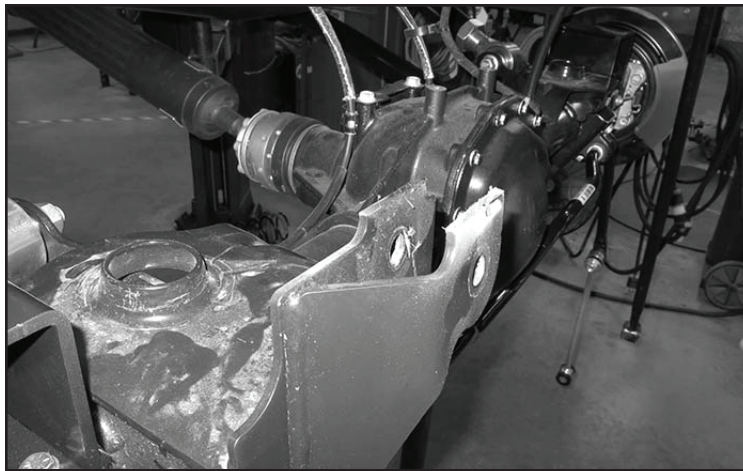

FIGURE 30 - STEP 29

30. Install the FT50778 (Rear track bar bracket) onto the factory bracket. Insert the supplied 9/16" X 3" bolt. Mark the 3 holes using the new bracket as a template. **SEE FIGURES 31-33.** Remove and drill the 3 holes using a 7/16" drill bit.



FIGURE 31 - STEP 30



FIGURE 32 - STEP 30

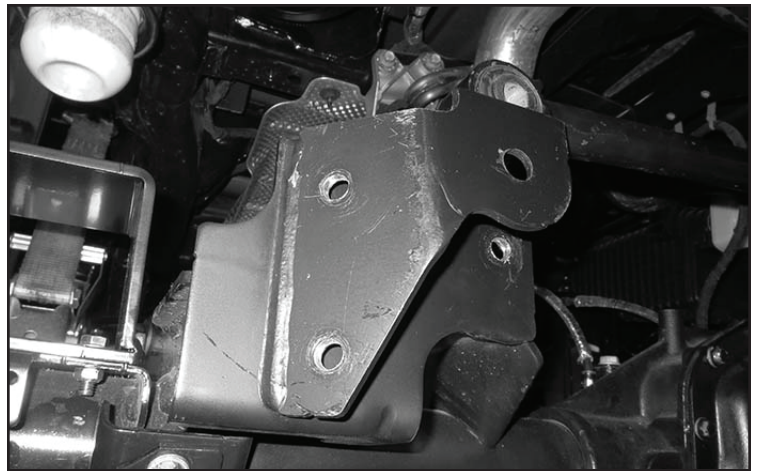

FIGURE 33 - STEP 30

31. Reinstall the FT50778 (Track bar bracket) using the supplied 7/16" x 1" hardware. **DO NOT TIGHTEN.** Install FT50592 (Rear track bar sleeve) using the supplied 9/16" x 3" bolt and hardware. **SEE FIGURES 34** Torque 7/16" hardware to 83 ft-lbs and 9/16" to 148 ft-lbs.

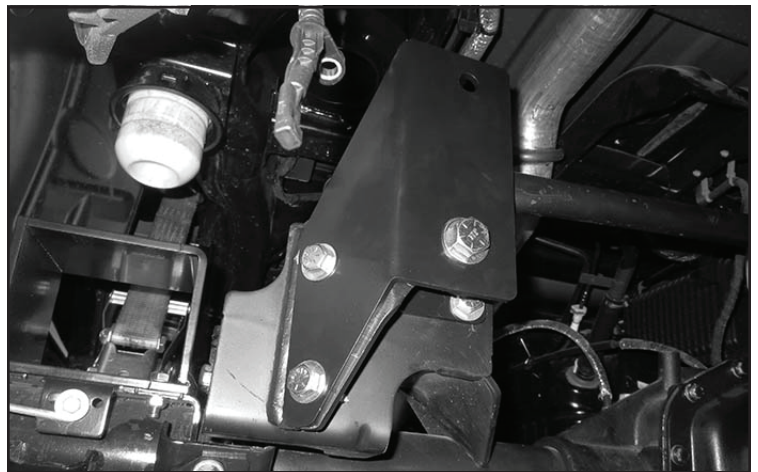

FIGURE 34 - STEP 31

32. **INSTALL THE REAR COILS USING THE INSTRUCTIONS PROVIDED IN THAT BOX KIT.**

33. Install FTS6333 (Stealth shocks) using the factory hardware. **NOTE: If installing Dirt Logic shocks do so with the provided instructions.** Torque to 100 ft-lbs.
34. Install the FT1004 (Half bushings) and FT404739 (Sleeves) into FT1599-2-4 (Rear sway bar links). Then, install the new links to the sway bar and sway bar mount on the frame using supplied M12 x 70mm bolt and large O.D. washer for the upper location and M12 x 70mm bolt regular washer, large O.D. washer and nut for the lower. Use the larger washer on the nut side. **NOTE: The new end link will need to be installed on the inside of the sway bar and axle mount.** Torque to 65 ft-lbs **SEE FIGURE 29**

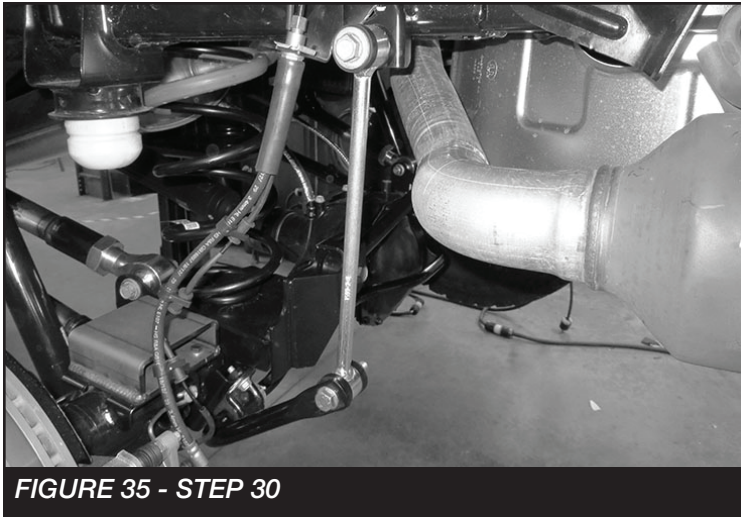

FIGURE 35 - STEP 30

35. Reinstall the track bar to the new track bar bracket using the factory hardware. Torque to 148 ft-lbs.
36. Using the brake line bracket as a template pull down 1" from where the factory location. Mark and drill using a 9/32" drill bit. **NOTE: Drill through the mount as well as the frame.** Then, install the bracket using the supplied 5/16" self tapping bolt. **SEE FIGURES 30-31**

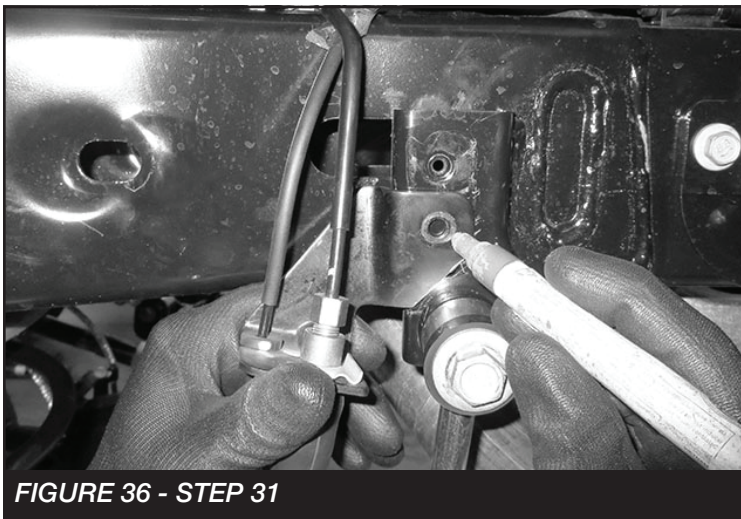

FIGURE 36 - STEP 31

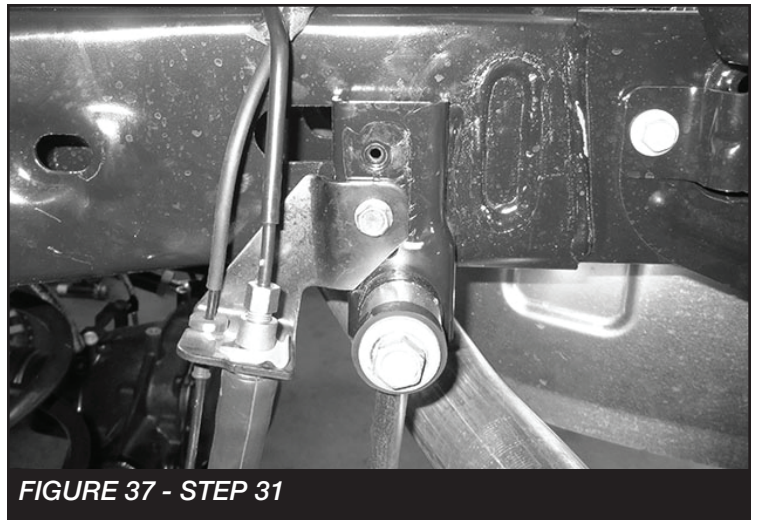

FIGURE 37 - STEP 31

37. Install tires and wheels and torque lug nuts to wheel manufacturer's specifications. Turn front tires left to right and check for appropriate tire clearance. **Note - Some oversized tires may require trimming of the front bumper & valance.**
38. Check front end alignment and set to factory specifications. Readjust headlights.
39. Recheck all bolts for proper torque.
40. Recheck brake hoses, ABS wires and suspension parts for proper tire clearance while turning tires fully left to right.
41. Check the fluid in the front and rear differential and fill if needed with factory specification differential oil. **Note - some differentials may expel fluid after filling and driving. This can be normal in resetting the fluid level with the new position of the differential/s.**
42. Install Driver Warning Decal. Complete product registration card and mail to Fabtech in order to receive future safety and technical bulletins on this suspension.

Vehicles that will receive oversized tires should check ball joints, uniballs and all steering components every 2500-5000 miles for wear and replace as required.

RE-TORQUE ALL NUTS, BOLTS AND LUGS AFTER 50 MILES AND PERIODICALLY THEREAFTER.

For technical assistance call: **909-597-7800**

- Product Warranty and Warnings -

Fabtech provides a Limited Lifetime Warranty to the original retail purchaser who owns the vehicle, on which the product was originally installed, for defects in workmanship and materials.

The Limited Lifetime Warranty excludes the following Fabtech items; bushings, bump stops, ball joints, tie rod ends, limiting straps, cross shafts, heim joints and driveshafts. These parts are subject to wear and are not considered defective when worn. They are warranted for 60 days from the date of purchase for defects in workmanship.

Dirt Logic and Performance Coilover take apart shocks are considered a serviceable shock with a one year warranty on leakage only. Service seal kits are available separately for future maintenance. All other shocks are covered under our Limited Lifetime Warranty.

Fabtech does not warrant any product for finish, alterations, modifications and/or installation contrary to Fabtech's instructions. Alterations to the finish of the parts including but not limited to painting, powder coating, plating and/or welding will void all warranties. Some finish damage may occur to parts during shipping, which is considered normal and is not covered under warranty.

Fabtech products are not designed nor intended to be installed on vehicles used in race applications or for racing purposes or for similar activities. (A "RACE" is defined as any contest between two or more vehicles, or any contest of one or more vehicle against the clock, whether or not such contest is for a prize). This warranty does not include coverage for police or taxi vehicles, race vehicles, or vehicles used for government or commercial purposes. Also excluded from this warranty are sales outside of the United States of America.

Installation of most suspension products will raise the center of gravity of the vehicle and will cause the vehicle to handle differently than stock. It may increase the vehicle's susceptibility to a rollover, on road and off road, at all speeds. Extreme care should be taken to operate the vehicle safely at all times to prevent rollover or loss of control resulting in serious injury or death. Fabtech front end Desert Guards may impair the deployment or operation of vehicles equipped with supplemental restraining systems/air bag systems and should not be installed if the vehicle is equipped as so.

Fabtech makes every effort to ensure suspension product compatibility with all vehicles listed on the website, but due to unknown auto manufacturer's production changes and/or inconsistencies by the auto manufacturer, Fabtech cannot be responsible for 100% compatibility, including the fitment of tire and wheel sizes listed. The Tire and Wheel sizes listed in Fabtech's website are only a guideline for street driving with noted fender trimming. Fabtech is not responsible for damages to the vehicle's body or tires. Fabtech is not responsible for premature wear of factory components due to the installation of oversized tires and wheels.

Fabtech's obligation under this warranty is limited to the repair or replacement, at Fabtech option, of the defective product only. All costs of removal, installation or re-installation, freight charges, incidental or consequential damages are expressly excluded from this warranty. Fabtech is not responsible for damages and/or warranty of other vehicle parts related or non related to the installed Fabtech product. This warranty is expressly in lieu of all other warranties expressed or implied. This warranty shall not apply to any product that has been subject to accident, negligence, alteration, abuse or misuse as determined by Fabtech.

Fabtech suspension components must be installed as a complete system including shocks as shown on our website. All warranties will become void if Fabtech parts are combined and/or substituted with other aftermarket suspension products. Combination and/or substitution of other aftermarket suspension parts may cause premature wear and/or product failure resulting in an accident causing injury or death. Fabtech does not warrant products not manufactured by Fabtech.

Depending on the condition of the factory suspension components retained after the installation of a Fabtech suspension not all vehicles may have the same ride stance front to rear as described in the website. The blue color of suspension components shown in all Fabtech photographs are for display purposes only. Majority of all Fabtech components will be black specifically where noted with part numbers ending in BK.

Installation of Fabtech product may void the vehicles factory warranty; it is the consumer's responsibility to check with their local vehicle's dealer for warranty disposition before the installation of the product. Some state laws may prohibit modification of suspension to a vehicle in whole or in part. It is the responsibility of the installer and consumer to consult local laws prior to the installation of any Fabtech suspension product to comply with such written laws.

It is the responsibility of the distributor and/or the retailer to review all warranties and warnings of Fabtech products with the consumer prior to purchase.

Fabtech reserves the right to super cede, discontinue, change the design, finish, part number and/or application of parts when deemed necessary without written notice. Fabtech is not responsible for misprints or typographical errors within the website or price sheet. For the most recent Product Warranty and Warnings visit our website www.fabtechmotorsports.com



FTS801502		2.25 Dirt Logic SS w/ Resi (3" JT Rear)
1	FT86101	2.25 Resi Kit
1	FT801502i	INSTRUCTIONS
1	FT86008	HARDWARE & BUSHING KIT 8

Thank you for purchasing Dirt Logic shocks, the finest off-road shock in the industry. Each unit is built to exacting standards and is properly tuned specifically for your vehicle. Dirt Logic shocks are designed and built to both beautify and upgrade your suspension system.

How To Care For Your Dirt Logic Shocks

Dirt Logic shocks have been designed as a take apart, serviceable, race style unit. That means, just like a race shock, it will need to be maintained and periodically rebuilt. The tight tolerances of this provide the exceptional ride and performance you are paying for but do require maintenance which is normal in a take apart shock like a Dirt Logic.

Externally, the shock should be kept clean at all times and kept free of dirt, road salt or other corrosive elements. The unit should be routinely washed with a pH balanced cleaner to keep the finish looking new. Do not use any abrasive or aggressive cleaners or degreasers as it will harm the finish for life including the aluminum anodizing.

Internally, the shock has high performance seals that allow the shock to cycle at very high rates and provide exceptional damping in aggressive off-road conditions. These seals are a wearable item and may need to be replaced periodically to keep the shock functioning correctly. Our in house Shock Lab is equipped to handle these needs when necessary.

Caution – Read Before Installing

Stop – Call FABTECH customer service if any component of this product is missing. Do not return it to the place of purchase! For technical assistance call: 909-597-7800

This Dirt Logic Shock is shipped pressurized with Nitrogen. Do not remove tamper cap or warranty will be void.

If this shock is equipped with a reservoir hose, do not loosen or remove the hose or warranty will be void.

If this shock is equipped with a coil, be aware that the coil has some amount of preload from the factory and should not be removed. Removal of the coil will void the warranty.

If this shock product needs to be returned for any reason, it must be returned in its original packaging or warranty will be void.

Dirt Logic Shocks come with a one year warranty from the original date of purchase for defects in material or workmanship.

A spanner wrench can be purchased for future adjustment. (FTS89905 for 4.0, FTS98008 for 2.5, FTS98006 for 2.0)

If adjustment is needed. Jack up the vehicle to relieve tension on the Dirt Logic coil over before making adjustments or the top cap may come loose.

Should you have any questions regarding your Dirt Logic Shocks, please feel free to contact us.

- INSTRUCTIONS -

1. Install the bushings and sleeves into the 2.25" Dirt Logic Shock. Now install the shock by attaching the top cap end first and the rod end second. Take care to compress the shock when installing the rod end as the shock is under pressure and will require leverage and strength to accomplish this task. This would be best done with the vehicle on a hoist with the suspension at its most extended length. Torque to 86 ft-lbs
2. Install the resi to the shock body using the provided urethane isolators and clamps. Rotate the resi so it is clear of the frame or any part that will damage it during a full cycle. **SEE FIGURES BELOW**



**RETORQUE ALL NUTS, BOLTS AND LUGS
AFTER 50 MILES AND PERIODICALLY
THEREAFTER.**

For technical assistance call: **909-597-7800**

- Product Warranty and Warnings -

Fabtech provides a Limited Lifetime Warranty to the original retail purchaser who owns the vehicle, on which the product was originally installed, for defects in workmanship and materials.

The Limited Lifetime Warranty excludes the following Fabtech items; bushings, bump stops, ball joints, tie rod ends, limiting straps, cross shafts, heim joints and driveshafts. These parts are subject to wear and are not considered defective when worn. They are warranted for 60 days from the date of purchase for defects in workmanship.

Dirt Logic and Performance Coilover take apart shocks are considered a serviceable shock with a one year warranty on leakage only. Service seal kits are available separately for future maintenance. All other shocks are covered under our Limited Lifetime Warranty.

Fabtech does not warrant any product for finish, alterations, modifications and/or installation contrary to Fabtech's instructions. Alterations to the finish of the parts including but not limited to painting, powder coating, plating and/or welding will void all warranties. Some finish damage may occur to parts during shipping, which is considered normal and is not covered under warranty.

Fabtech products are not designed nor intended to be installed on vehicles used in race applications or for racing purposes or for similar activities. (A "RACE" is defined as any contest between two or more vehicles, or any contest of one or more vehicle against the clock, whether or not such contest is for a prize). This warranty does not include coverage for police or taxi vehicles, race vehicles, or vehicles used for government or commercial purposes. Also excluded from this warranty are sales outside of the United States of America.

Installation of most suspension products will raise the center of gravity of the vehicle and will cause the vehicle to handle differently than stock. It may increase the vehicle's susceptibility to a rollover, on road and off road, at all speeds. Extreme care should be taken to operate the vehicle safely at all times to prevent rollover or loss of control resulting in serious injury or death. Fabtech front end Desert Guards may impair the deployment or operation of vehicles equipped with supplemental restraining systems/air bag systems and should not be installed if the vehicle is equipped as so.

Fabtech makes every effort to ensure suspension product compatibility with all vehicles listed on the website, but due to unknown auto manufacturer's production changes and/or inconsistencies by the auto manufacturer, Fabtech cannot be responsible for 100% compatibility, including the fitment of tire and wheel sizes listed. The Tire and Wheel sizes listed in Fabtech's website are only a guideline for street driving with noted fender trimming. Fabtech is not responsible for damages to the vehicle's body or tires. Fabtech is not responsible for premature wear of factory components due to the installation of oversized tires and wheels.

Fabtech's obligation under this warranty is limited to the repair or replacement, at Fabtech option, of the defective product only. All costs of removal, installation or re-installation, freight charges, incidental or consequential damages are expressly excluded from this warranty. Fabtech is not responsible for damages and/or warranty of other vehicle parts related or non related to the installed Fabtech product. This warranty is expressly in lieu of all other warranties expressed or implied. This warranty shall not apply to any product that has been subject to accident, negligence, alteration, abuse or misuse as determined by Fabtech.

Fabtech suspension components must be installed as a complete system including shocks as shown on our website. All warranties will become void if Fabtech parts are combined and/or substituted with other aftermarket suspension products. Combination and/or substitution of other aftermarket suspension parts may cause premature wear and/or product failure resulting in an accident causing injury or death. Fabtech does not warrant products not manufactured by Fabtech.

Depending on the condition of the factory suspension components retained after the installation of a Fabtech suspension not all vehicles may have the same ride stance front to rear as described in the website. The blue color of suspension components shown in all Fabtech photographs are for display purposes only. Majority of all Fabtech components will be black specifically where noted with part numbers ending in BK.

Installation of Fabtech product may void the vehicles factory warranty; it is the consumer's responsibility to check with their local vehicle's dealer for warranty disposition before the installation of the product. Some state laws may prohibit modification of suspension to a vehicle in whole or in part. It is the responsibility of the installer and consumer to consult local laws prior to the installation of any Fabtech suspension product to comply with such written laws.

It is the responsibility of the distributor and/or the retailer to review all warranties and warnings of Fabtech products with the consumer prior to purchase.

Fabtech reserves the right to super cede, discontinue, change the design, finish, part number and/or application of parts when deemed necessary without written notice. Fabtech is not responsible for misprints or typographical errors within the website or price sheet. For the most recent Product Warranty and Warnings visit our website www.fabtechmotorsports.com.