



Installation Instructions



*2007 - 17 GM Tahoe & Yukon 4WD - 2wd w/Auto
Ride, Basic System
FTS21040BK / FTS21041BK / FTS21042BK*

Fabtech Motorsports 4331 Eucalyptus Ave. Chino, CA 91710
Tech Line 909-597-7800 Fax 909-597-7185 Web www.fabtechmotorsports.com



*2007 - 17 GM Tahoe & Yukon Basic System
FTS21040BK / FTS21041BK / FTS21042BK*

PARTS LIST

FTS21040BK Chevy 2007 Box 1		
Qty	Part #	Description
1	FT20282BK	Frt Crossmember
1	FT20283BK	Rear Crossmember
2	FT20284BK	Crossmember Support Tube
1	FT20347	Driver Diff Bracket
1	FT20348	Pass. Diff Bracket
2	FT20287BK	Impact Tube
2	FT20288BK	Impact Tube Bracket
1	FT20304BK	Diff Skid Plate
1	FT20308	Hardware Kit
1	FT20399	Hdwr Sub-Assembly Kit

FT20399 Hdwr Sub-Assembly Kit		
Qty	Part #	Description
1	FT1044	Bushing Kit
2	FT20277	Drv./Pass Outer Tie Rod End
1	FT20300	1/4" Wheel Spacer
1	FT20313	Drv. Frt. Brake Line Bracket
1	FT20314	Pass. Frt. Brake Line Bracket

FTS21042BK Chevy 2007 Box 3 Coil Spacer		
Qty	Part #	Description
1	FT20295	Hardware Kit
2	FT20323BK	Shock Extension
4	FT20568BK	Shock Brackets
2	FT20339BK	Shock Mount To Arm
1	FT20397	Hdwr Sub-Assembly Kit

FT20397 Hdwr Sub-Assembly Kit		
Qty	Part #	Description
4	FT1036	Bushing Lower Mount
2	FT148	Sleeve
4	FT20342	Alum. Shock Mount Bushing Half "non- auto ride bushing halves"
4	FT20352	Lower Mount Shim (forged steel a-arms only)

FTS21041BK Chevy 2007 Box 2		
Qty	Part #	Description
1	FTS20276D	Drv. Spindle
1	FTS20276P	Pass. Spindle
2	FT20289	C.V. Spacer
2	FT20602	Sway Bar Link Bracket D/P.
1	FT20312	Sway Bar Frame Bracket Drv.
1	FT20318	Sway Bar Frame Bracket Pass

Note: If your vehicle is equipped with the Auto Ride system, use the FT20351 Aluminum Shock Mount Bushing Halves that are included with the FTS21051BK Rear Coil Spring kit. The FT20342 Aluminum Shock Mount Bushing Halves that are included with this kit will not work with the Auto Ride System and should be discarded.



*2007 - 17 GM Tahoe & Yukon Basic System
FTS21040BK / FTS21041BK / FTS21042BK*

Hardware Kit FT20308					
Qty	Description	Location	Qty	Description	Location
2	5/8"-11 x 5" Hex Cap Bolt	Front Crossmember	2	1/2"-13 x 1 3/4" Hex Cap Bolt	Diff Drop Bracket Dr.
2	5/8"-11 x 5 3/4" Hex Cap Bolt	Rear Crossmember	2	1/2"-13 C-Locks	
8	5/8" SAE Flat Washer		4	1/2" SAE Flat Washer	
4	5/8"-11 C-Locks		2	9/16"-12 x 1 3/4" Hex Cap Bolt	Diff Drop Brkt Pass.
2	18mm- 2.50 x 50mm Bolt	Front Sway bar	2	9/16"-12 C-Lock Nut	
2	18mm- 2.50 C-Locks		4	9/16" SAE Flat Washer	
4	18mm Flat Washer		2	7/16"-14 x 1 1/4" Hex Cap Bolt	Skid Plate
4	7/16"-14 x 3 1/2" Bolt	Impact Struts	1	1/2"-12 x 1 1/4" Hex Cap Bolt	
4	7/16"-14 C-Locks		2	7/16"-14 C-Lock Nut	
8	7/16" SAE Flat Washer		1	1/2"-13 C-Lock Nut	
4	1/4"-20 x 3/4" Hex Cap Bolt	Front Brake Drop Brkt	4	7/16" SAE Flat Washer	
4	1/4"-20 C-Locks		2	1/2" SAE Flat Washer	
8	1/4" SAE Flat Washer		12	10mm 1.50 x 50mm	Axle Bolts
4	7/16"-14 x 2 1/4" Hex Cap Bolt	Sway Bar Drop Bracket	12	10mm Flat Washer	
4	7/16"-14 C-Locks		2	1/4"-20 x 3/4" Hex Cap Bolt	ABS Cable@Spindle
8	7/16" SAE Washer		2	1/4" Split Washer	
4	10mm x 1.5 x 30mm Bolt		2	1/4" SAE Flat Washer	
4	10mm x 1.5 C-Lock Nut		2	1/4" Adel / Line Clamp	
8	10mm Flat Washer		6	6" Cable Ties	
			1	Thread Locking Compound	

Hardware Kit FT20295		
Qty	Description	Location
4	7/16"-14 x 2 1/2" Hex Cap Bolt	Strut Mnt Brkt @ L.C.A.
4	7/16"-14 C-Locks	
8	7/16" SAE Flat Washer	
4	1/2"-13 x 4" Hex Cap Bolt	Mount @ Lwr. Ctrl Arm
2	1/2"-13 x 3 3/4" Hex Cap Bolt	Front Lower Strut
6	1/2"-13 C-Locks	
12	1/2" SAE Flat Washer	
8	5/16"-18 x 1" Hex Cap Bolt	Strut Mount Brackets
8	5/16"-18 C-Locks	
16	5/16" SAE Flat Washer	



*2007 - 17 GM Tahoe & Yukon Basic
System FTS21040BK / FTS21041BK /
FTS21042BK*

FT20300 WHEEL SPACER IS TO BE USED WITH THE SPARE TIRE ONLY. IT IS FOR TEMPORARY USE ONLY. THE WHEEL SPACER IS TO BE GIVEN TO THE END CONSUMER AND PLACE WITH THE FACTORY SPARE WHEEL AND TIRE. WHEEL SPACERS ARE FOR LOW SPEED OPERATION ONLY, 50 MPH AND SLOWER.

DO NOT ALTER THE FINISH OF THESE COMPONENTS, EXAMPLE- CHROMING, ZINC PLATING OR PAINTING. CHANGING THE FINISH CAN CAUSE STRUCTURAL FATIGUE OF COMPONENTS.

SUSPENSION SYSTEM MUST BE INSTALLED WITH FABTECH SHOCK ASBORBERS

VEHICLES THAT WILL RECEIVE OVERSIZED TIRES SHOULD CHECK BALL JOINTS, TIE RODS ENDS AND IDLER ARM EVERY 2500-5000 MILES FOR WEAR AND REPLACE AS NEEDED

CHECK ALL PARTS INCLUDED IN THIS KIT TO THE PARTS LIST ABOVE BEFORE BEGINNING INSTALLATION OF THE KIT. IF ANY PIECES ARE MISSING, CONTACT FABTECH AT 909-597-7800

READ ALL INSTRUCTIONS THOROUGHLY FROM START TO FINISH BEFORE BEGINNING INSTALLATION! IF THESE INSTRUCTIONS ARE NOT PROPERLY FOLLOWED, SEVERE FRAME, DRIVELINE AND / OR SUSPENSION DAMAGE MAY RESULT.

NOTE- PRIOR TO THE INSTALLATION OF THIS SUSPENSION SYSTEM A FRONT END ALIGNMENT MUST BE PERFORMED AND RECORDED. DO NOT INSTALL THIS SYSTEM IF THE VEHICLE ALIGNMENT IS NOT WITHIN FACTORY SPECIFICATIONS. CHECK FOR FRAME AND SUSPENSION DAMAGE PRIOR TO INSTALLATION. THIS SUSPENSION SYSTEM DOES NOT REQUIRE WELDING FOR INSTALLATION. DO NOT WELD ANY OF THESE COMPONENTS.

THE INSTALLATION OF THIS SUSPENSION SYSTEM SHOULD BE PERFORMED BY TWO PROFESSIONAL MECHANICS.

FABTECH RECOMMEND'S A 17X8 WHEEL WITH A 5" BACK SPACING WITH A 315/70R17 TIRE

THIS KIT NOT RECOMMENDED FOR THE 2WD SUBURBAN.

BE SURE TO USE THREAD LOCKING COMPOUND ON ALL HARDWARE.

TOOL LIST: (NOT INCLUDED)

- **FLOOR JACK & JACK STANDS**
- **ASSORTED METRIC AND S.A.E SOCKETS, & WRENCHES**
- **LARGE C CLAMP OR C CLAMP VISE GRIPS**
- **DIE GRINDER WITH CUTOFF WHEEL OR SAWZALL**
- **TORQUE WRENCH**

DRIVELINE VIBRATION MAY OCCUR AND WILL REQUIRE PART #FTS21192 (CV DRIVESHAFT KIT)

FRONT SUSPENSION INSTRUCTIONS:

1. Disconnect the negative terminal on the battery. With the vehicle on level ground and the emergency brake set, block the rear tires. Jack up the front end of the truck and support the frame rails with jack stands. **NEVER WORK UNDER AN UNSUPPORTED VEHICLE!** Remove the front tires.
2. Disconnect the tie rod ends from the steering knuckle by striking the knuckle to dislodge the tie rod end. Use care not to damage the tie rod end when removing. SEE PHOTO BELOW



3. Unplug the ABS brake connection from the frame and control arm. Remove the brake hose bracket from the steering knuckle. Remove the brake hose bracket from the strut bucket and secure the brake caliper to the frame out of the way. **DO NOT ALLOW THE BRAKE CALIPER TO HANG FROM THE BRAKE LINE HOSE.** SEE PHOTO BELOW



4. Remove the wheel stud clips and discard. Remove bearing cover, axle nut, washer, and rotor with hub bearing. (DO NOT REMOVE THE HUB FROM THE ROTOR). Retain parts and hardware for reinstallation. SEE PHOTOS IN NEXT COLUMN.

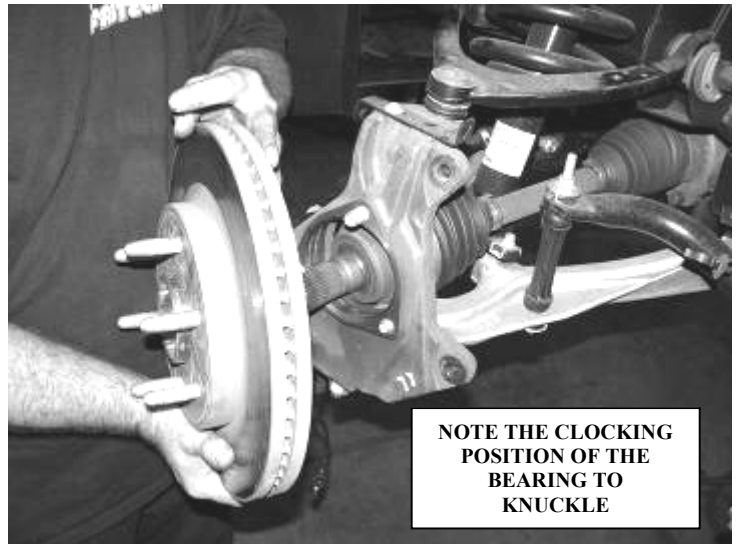

5. Remove the upper and lower ball joint nuts. Disconnect the upper and lower ball joints from the steering knuckle by striking the knuckle with a large hammer next to each ball joint on the knuckle to dislodge the ball joints. Use care not to hit the ball joints when removing. Save nuts and discard knuckle. SEE PHOTO BELOW

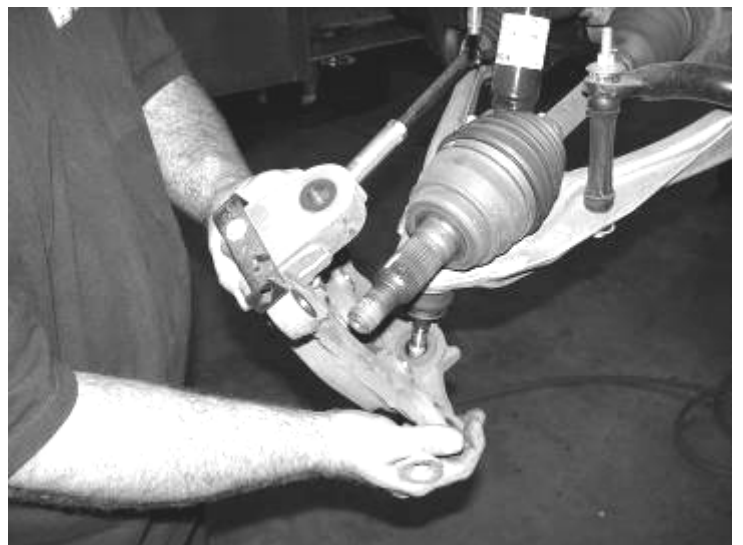

6. Remove the shock assembly and save with the hardware. Remove and discard the factory brake line bracket from the brake hose that attached the hose to the upper control arm. SEE PHOTO BELOW

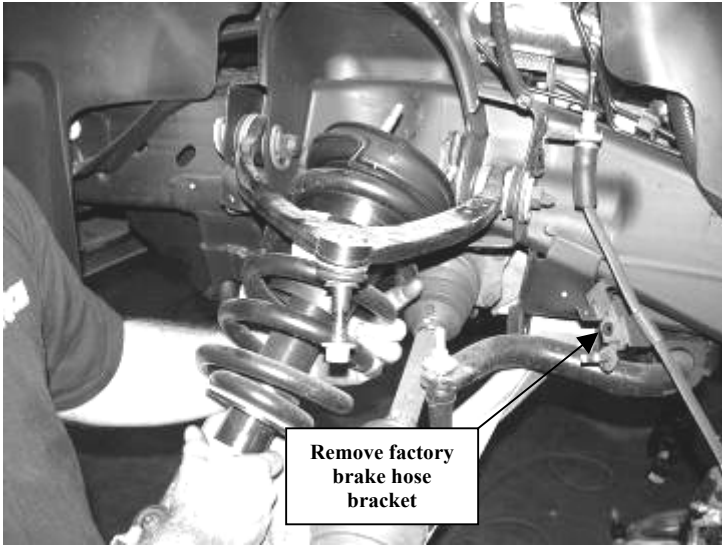

7. Disconnect and remove CV axles from differential housing and the sway bar endlinks and save. Discarding ONLY the CV axle hardware. SEE PHOTO BELOW.

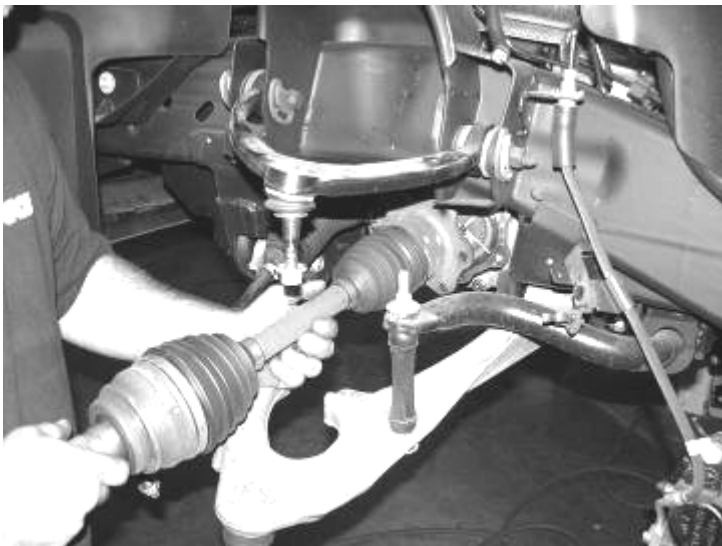

8. Remove the lower control arms from the frame and retain with the hardware for reinstallation. SEE PHOTO IN NEXT COLUMN.



9. Locate, remove, and save the sway bar, discard hardware. SEE PHOTO BELOW

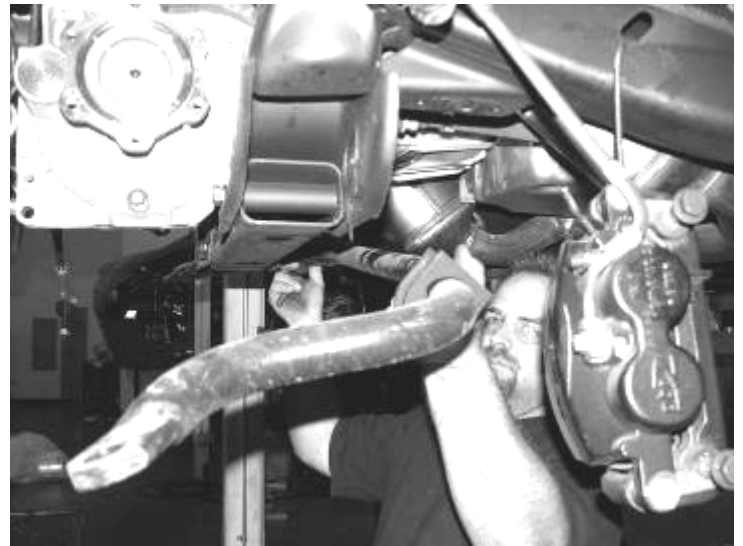

10. Remove front factory differential skid plate and splash shield and discard.
11. Disconnect front driveshaft from differential housing and retain bolts and u joint clamps for reinstallation. Locate, remove, and discard the factory rear crossmember with hardware.
12. Disconnect the electrical connection including the two retaining clamps and the vacuum line from differential housing. Remove differential housing assembly from vehicle. Retain hardware for reinstallation.
13. Locate the rear driver lower control arm mount on the frame. Measure 3" from the inside edge of the mount toward the frame and mark with a paint pen. Use a sawzall and cut the mount from the frame. SEE PHOTO ON NEXT PAGE.

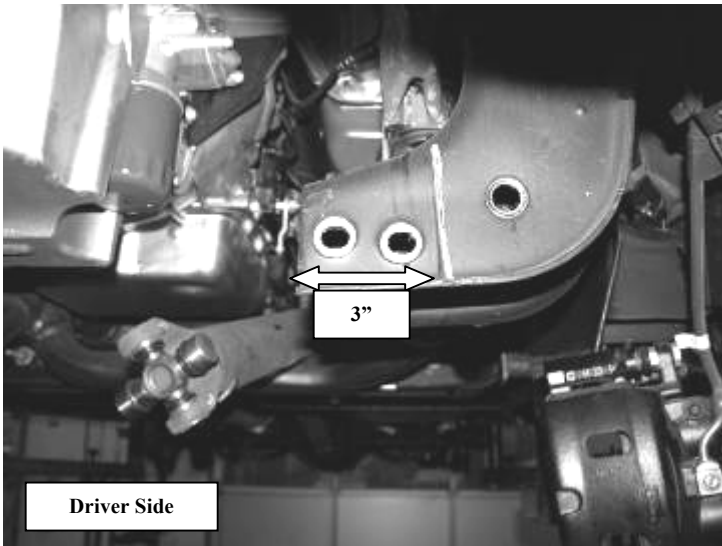

Driver Side

View from front of vehicle

14. Locate the rear passenger lower control arm mount on the frame. Measure 3 1/2" from the inside edge of the mount toward the frame and mark with a paint pen. Use a sawzall and cut the mount from the frame. SEE PHOTO BELOW

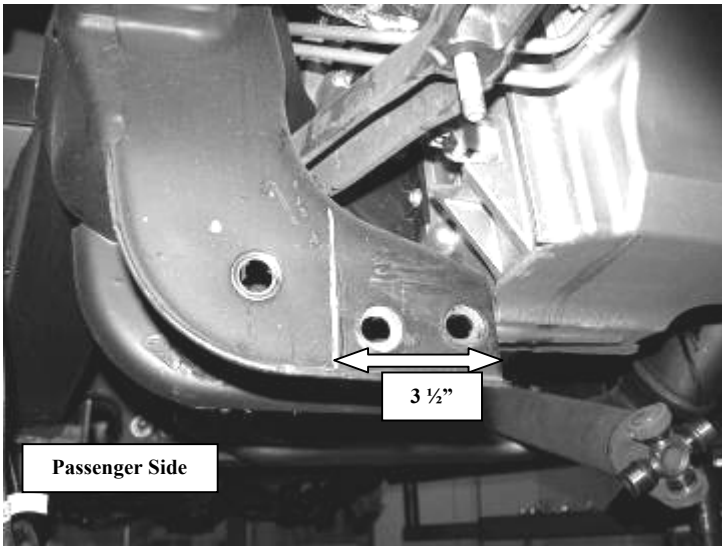

Passenger Side

View from front of vehicle

15. Locate the factory front lower control arm pockets. Grind 1/4" section from both Corners of the pockets as shown in the photo. SEE PHOTOS IN NEXT COLUMN

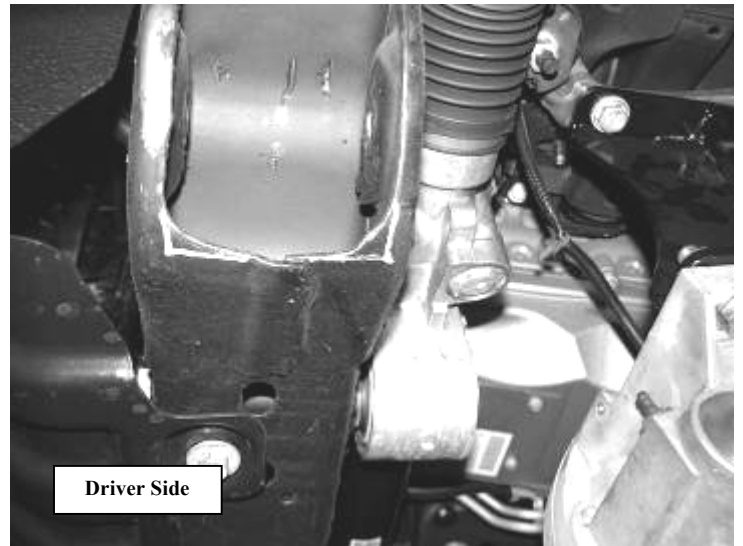

Driver Side

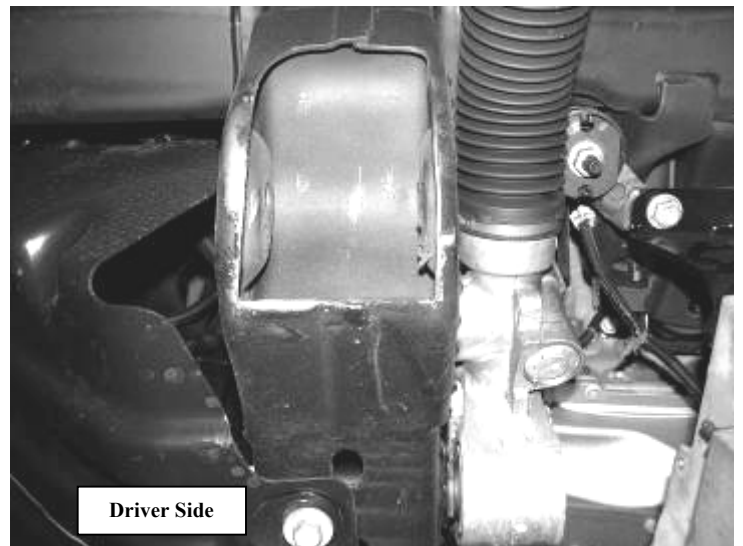

Driver Side

This step must be done on the Driver and Passenger Side

DUE TO VARIANCES IN EACH TRUCK, ADDITIONAL GRINDING MAY BE REQUIRED FOR PROPER FITMENT OF THE CROSSMEMBERS. USE THESE MEASUREMENTS AS A STARTING POINT AND CLEARANCE THE FRAME POCKETS AS NEEDED FOR PROPER FITMENT OF THE CROSSMEMBERS

16. Locate the front differential. The diff will need to be trimmed / cut in three places. The first is the 90 degree tab on the bottom front of the diff. Measure in 1 1/4" from the outer edge and cut with a sawzall as shown in photos. The second cut is the bottom rear gusset on the passenger side of the diff. Measure down 1/4" from the pinion side of the gusset and mark 1 1/2" long and 1/2" deep. Using a barrel sander, sand down the gusset as shown in photos below. The third cut is second gusset from the rear on the driver side of the diff. Mark the gusset 2 1/4" from the top and a 1/4" in. Using a barrel sander, sand down the gusset as shown in photos below. SEE PHOTOS ON NEXT PAGE

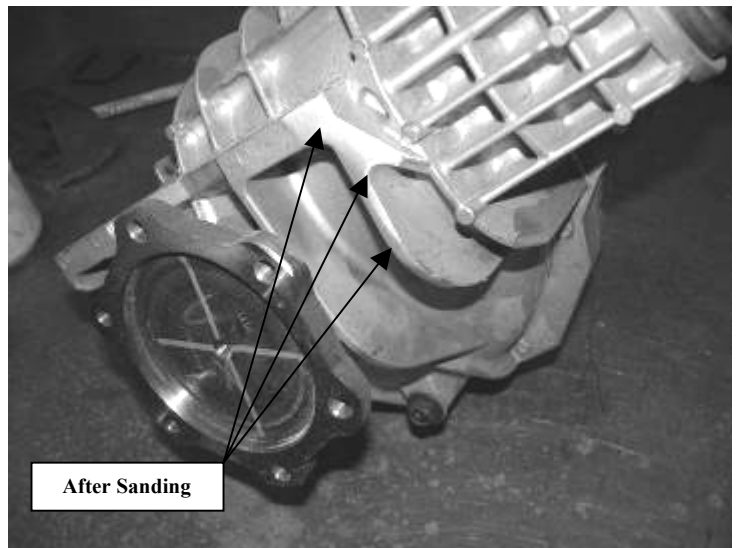
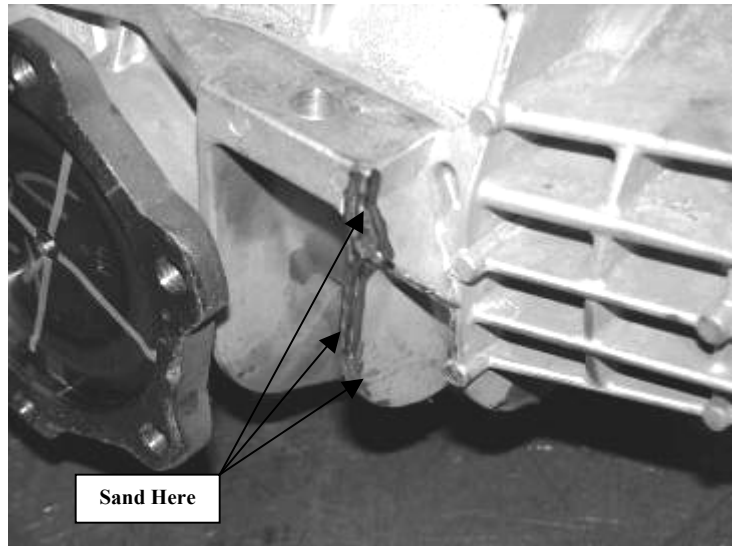
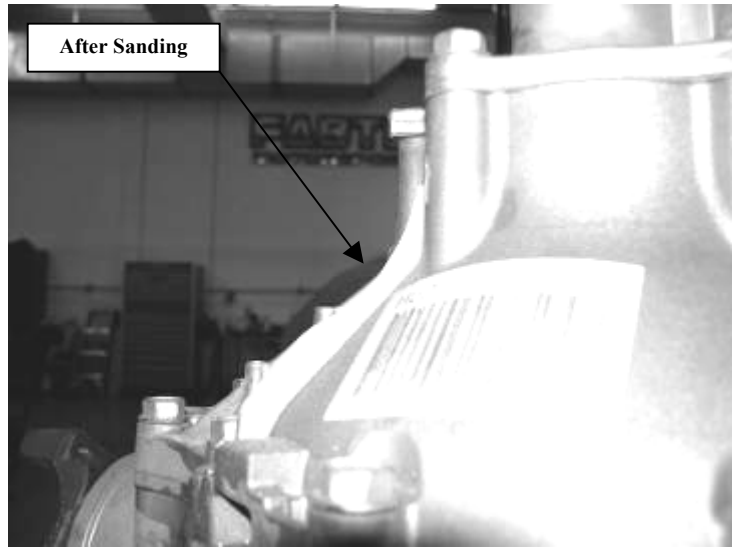
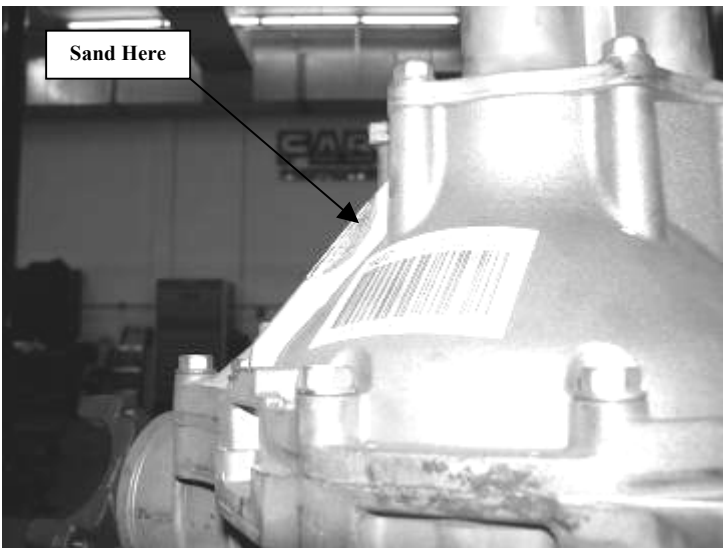
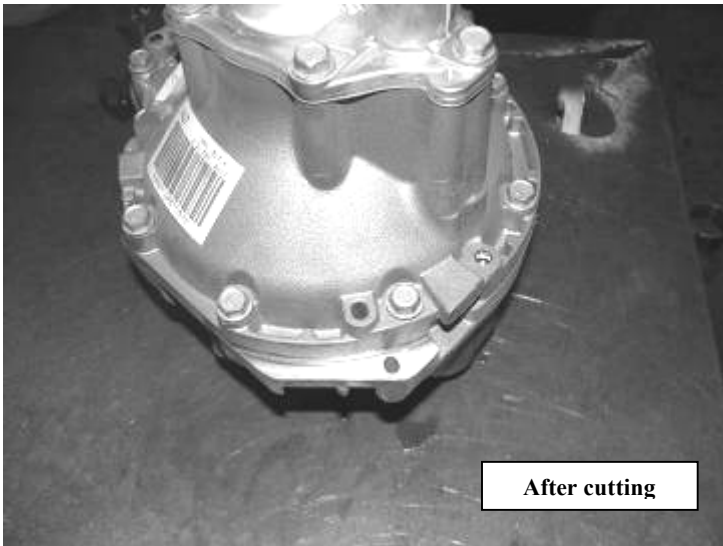
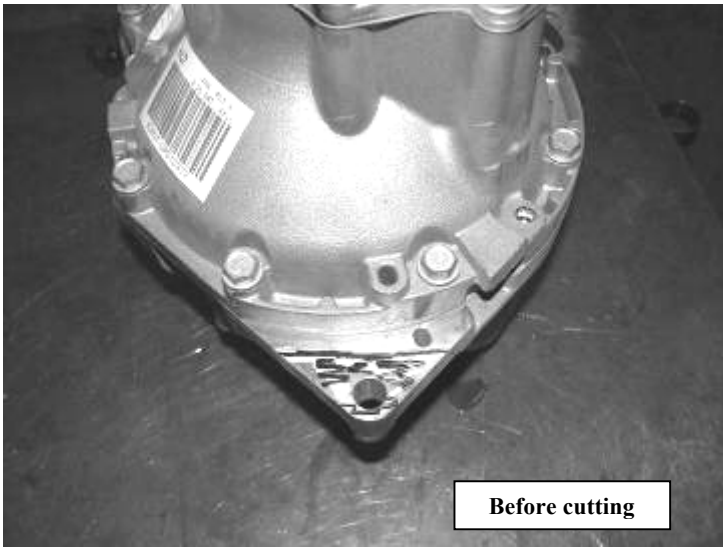

USE THESE MEASUREMENTS AS A STARTING POINT AND CLEARANCE THESE AREAS AS NEEDED FOR PROPER FITMENT OF THE DIFFERENTIAL

17. Locate the driver upper differential mount. The locating pin on this mount needs to be cut off. Using a die grinder with a cutoff wheel, cut the pin flush with the bracket. SEE PHOTOS ON NEXT PAGE

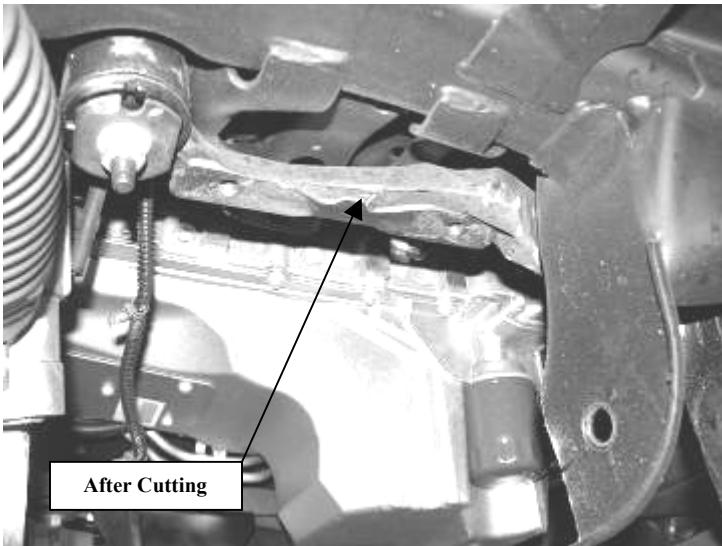
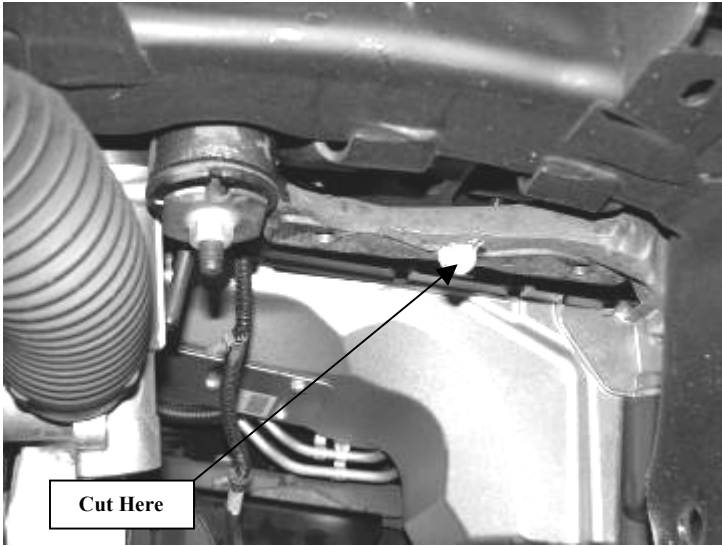

18. Locate FT20347 (driver) & FT20348 (pass) Diff. brackets and the factory diff hardware. Install the brackets to the factory mounts with the taller part of the bracket to the front of the truck with the factory hardware. Torque to 75 ft lbs. SEE PHOTOS BELOW AND IN NEXT COLUMN.

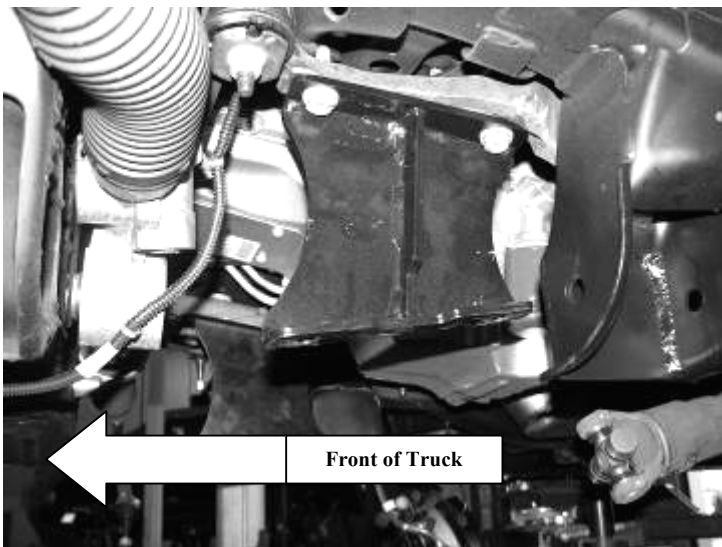

Driver Side

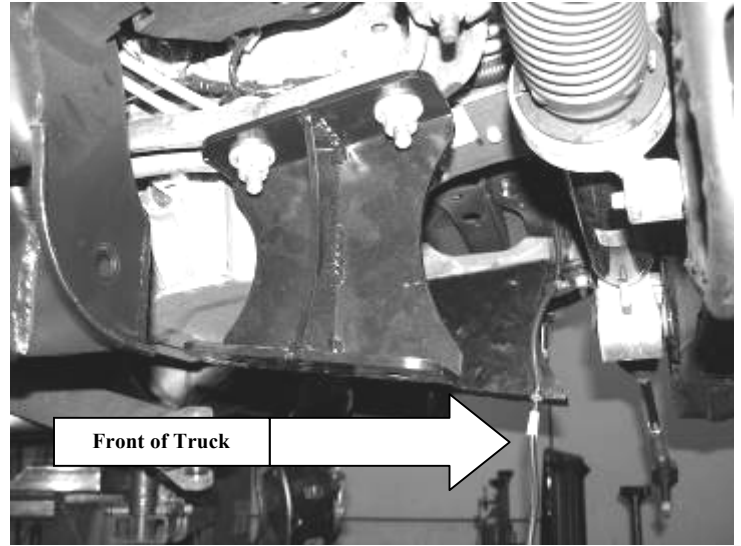

Passenger Side

19. Locate the supplied $\frac{1}{2}$ " x $1\frac{3}{4}$ " and $\frac{9}{16}$ " x $1\frac{3}{4}$ " hardware and the front diff. Install the diff onto the new drop brackets using the $\frac{1}{2}$ " hardware on the driver's side and the $\frac{9}{16}$ " on the passenger side. Torque the $\frac{1}{2}$ " hardware to 75ft lbs and the $\frac{9}{16}$ " to 95 ft lbs. Re-connect the electrical and vacuum connections back onto the diff. **(CHECK THE CLEARANCE OF THE DIFF TO THE FRAME IN SANDED AND CUT SPOTS ON THE DIFF. FOR ADAQUATE CLEARANCE TO THE FRAME AND CROSSMEMBER) .SEE PHOTO BELOW**



20. Locate and install FT20283 rear crossmember into the factory lower control arm pockets using the stock hardware and leave loose at this time. **(CHECK THE CLEARANCE OF THE DIFF TO CROSSMEMBER WHERE IT WAS SANDED DOWN IN STEP #18 FOR ADAQUATE CLEARANCE TO THE FRAME AND CROSSMEMBER) SEE PHOTO ON NEXT PAGE.**

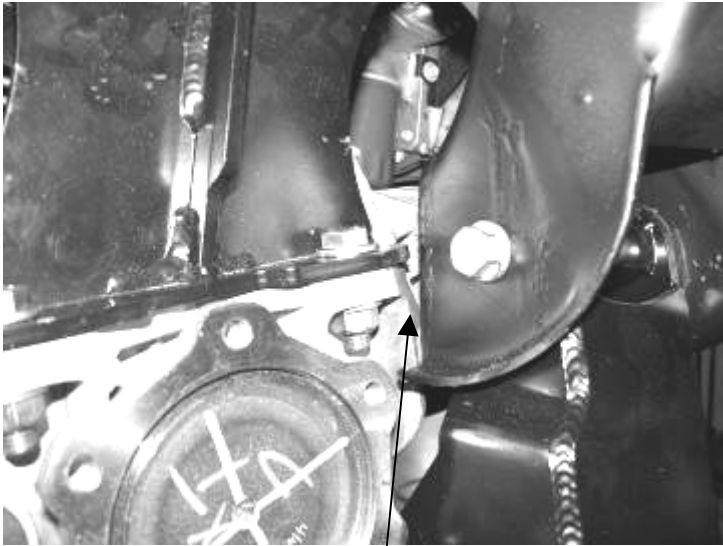

Check for clearance of the diff to the frame and crossmember

21. Locate and install FT20282 front crossmember into the factory lower control arm pockets using the stock hardware. Leave loose. SEE PHOTO BELOW

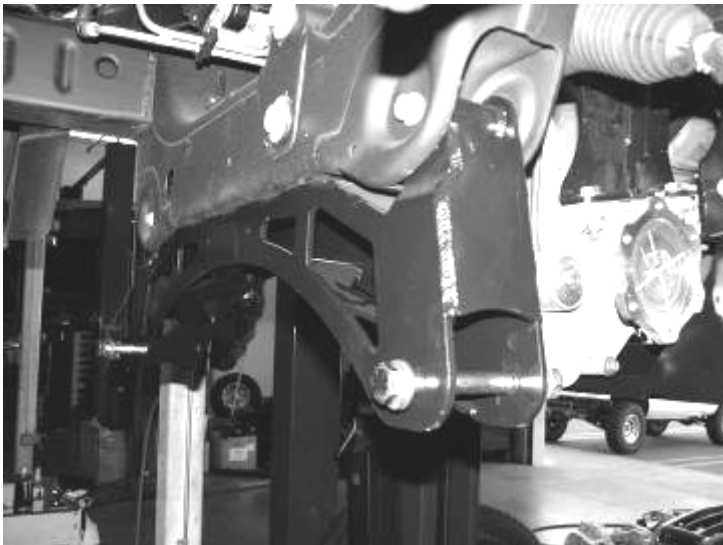

22. Locate FT20284 Crossmember Support Tubes. Install the lower control arms into the new crossmembers using the 5/8" x 5" hardware in the front pocket. Position the control arms into the crossmember and insert only the front 5/8" bolt just so that it is through the arm. Position the Support tube between the crossmembers and rotate them up to the locating tabs on the crossmember. Install 5/8" x 5 3/4" hardware in the rear pocket and the front bolt with hardware. Leave loose. SEE PHOTO IN NEXT COLUMN.

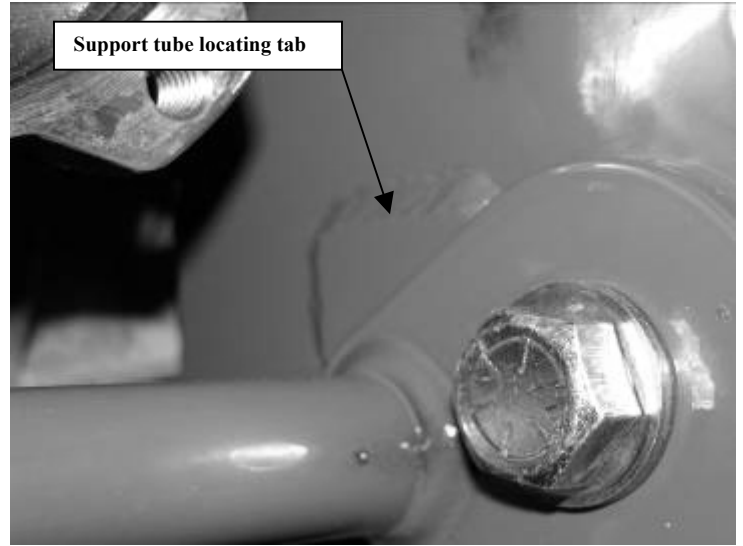

Driver side shown

23. Locate FT20304 Skid Plate and the supplied 1/2" x 1-1/4" hardware and attach the rear of the skid plate to the bottom of the rear crossmember. Use the supplied 7/16" x 1 1/4" hardware and attach the front of the skid plate to the front crossmember (make sure that the diff is clearanced enough to clear the skid plate). SEE PHOTO BELOW.

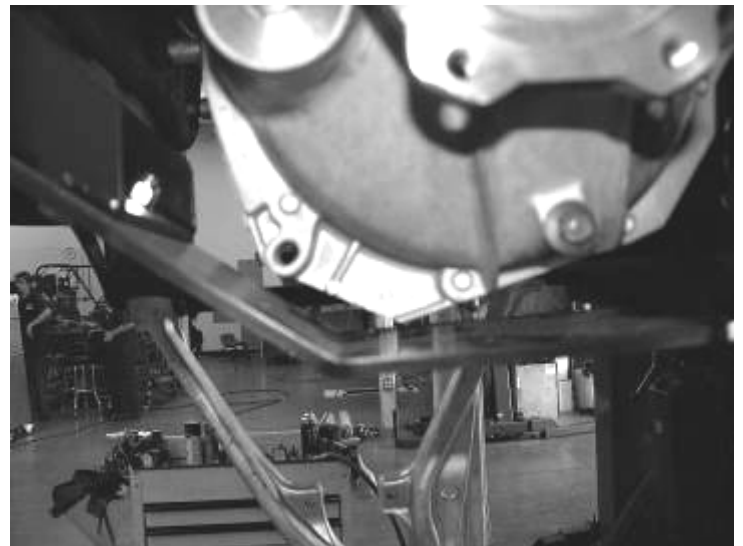

24. Torque the crossmember frame pocket bolts to 125 ft lbs, the lower control arm bolts to 110 ft lbs, the 1/2" skid plate hardware to 75 ft lbs, and the 7/16" to 50 ft lbs.
25. Locate the factory coilovers. Remove the nut clips from the cross-shaft and discard. Using a press, press out the cross-shaft and the bushing from the bottom of the coilover and discard. SEE PHOTOS ON NEXT PAGE.



26. Locate Box 3 FTS21042BK which has FT20339 Shock Mount to Arm, FT20323 Shock Extensions, FT20568 Shock Brackets, FT20342 (**non auto-ride**) or FT20351 (**auto-ride**) Aluminum Bushings , Hardware Kit FT20295, FT1036 Bushings, and FT148 Sleeves. Using a press, press the bushings and sleeves (with the provided lube) into the shock extension. Insert the Aluminum Bushings into the bottom of the factory shock. SEE PHOTOS IN NEXT COLUMN

Photo shows installation of FT20342 non-auto ride aluminum bushings

27. Place the Shock Brackets around the bottom of the shock and align with the aluminum sleeves. Position the shock extension over the brackets and also align with the aluminum sleeves. Locate the supplied $\frac{1}{2}$ " x 4" bolts and hardware and install through the aluminum bushing and the shock mount. Leave loose. Locate the $\frac{5}{16}$ " x 1" bolts and hardware and install into the shock brackets. Tighten the $\frac{5}{16}$ " hardware so the brackets are evenly spaced on the shock. Torque to 20 ft lbs. Torque the $\frac{1}{2}$ " hardware to 75 ft lbs. SEE PHOTOS BELOW AND IN NEXT COLUMN.

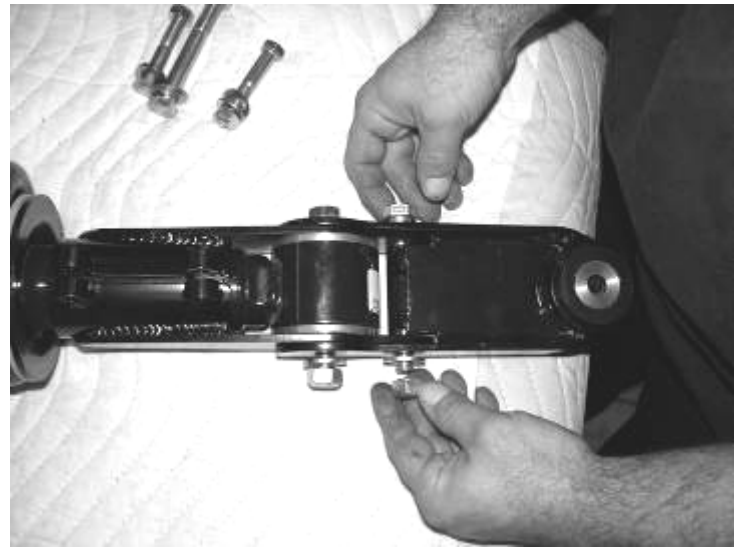
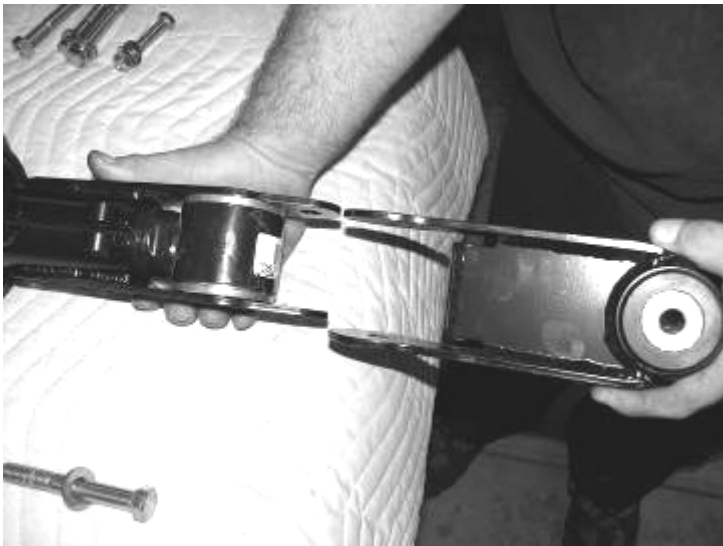

28. Locate the factory upper shock hardware. Install the shock into the factory shock bucket and leave loose. SEE PHOTOS BELOW AND ON NEXT PAGE.



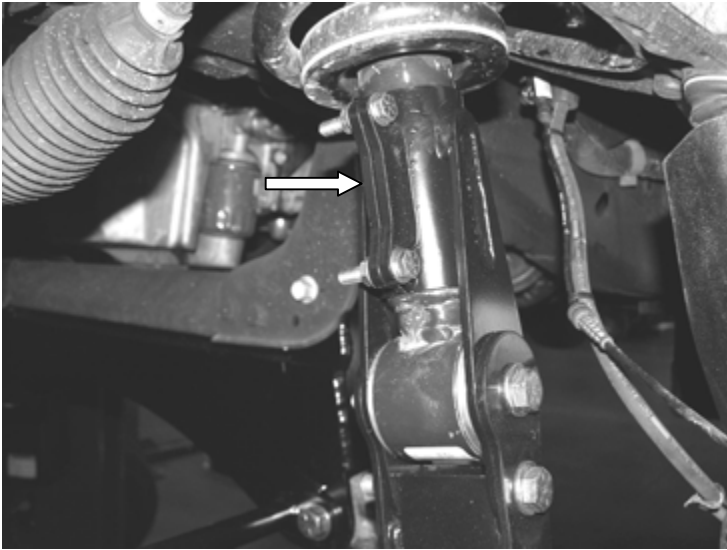
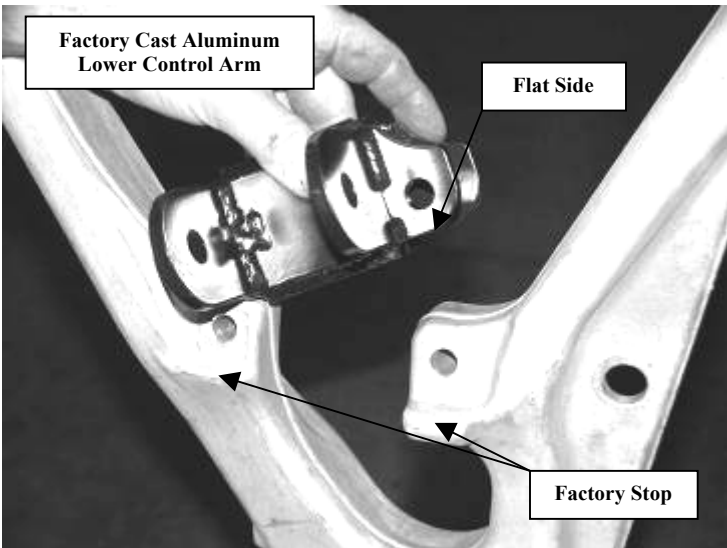
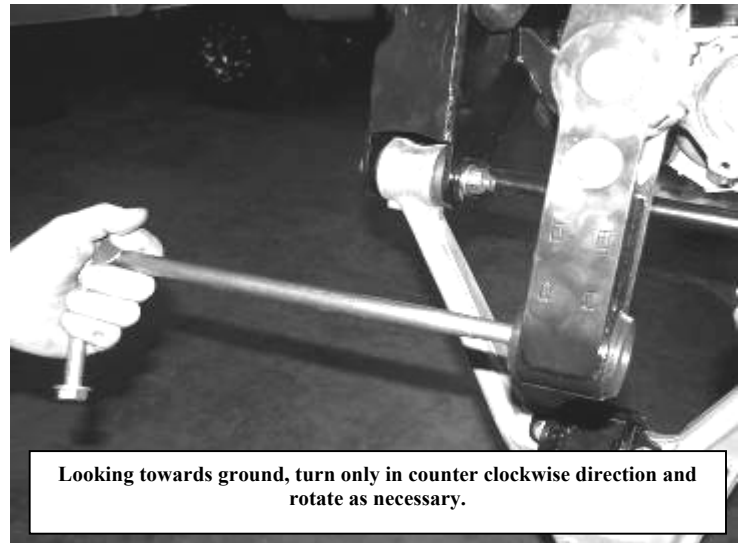
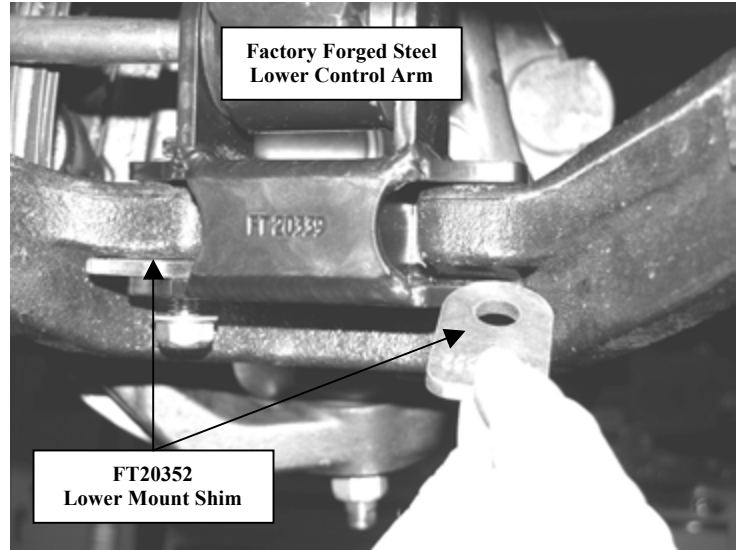

Photo shows new style shock brackets

29. Locate FT20339 Lower Shock Mount and the supplied 7/16" x 2 1/2" hardware. Position the mount onto the lower control arm so the flat side of the bracket will be flush with the stop on the arm. Attach with the 7/16" hardware and torque to 50 ft lbs. Rotate the lower control arm up and attach the strut to the new mount with the provided 1/2" x 3 3/4" hardware and torque to 75 ft lbs. (it may be necessary to rotate the shock and extension to attach). Torque the top shock bolts to 40 ft lbs. SEE PHOTOS BELOW AND IN NEXT COLUMN.



NOTE: If your truck has the Factory Forged Steel Lower Control Arms, you MUST use the FT20352 Lower Mount Shims. The shims will need to be positioned between the new mount and the control arm. SEE PHOTO IN NEXT COLUMN.



Looking towards ground, turn only in counter clockwise direction and rotate as necessary.

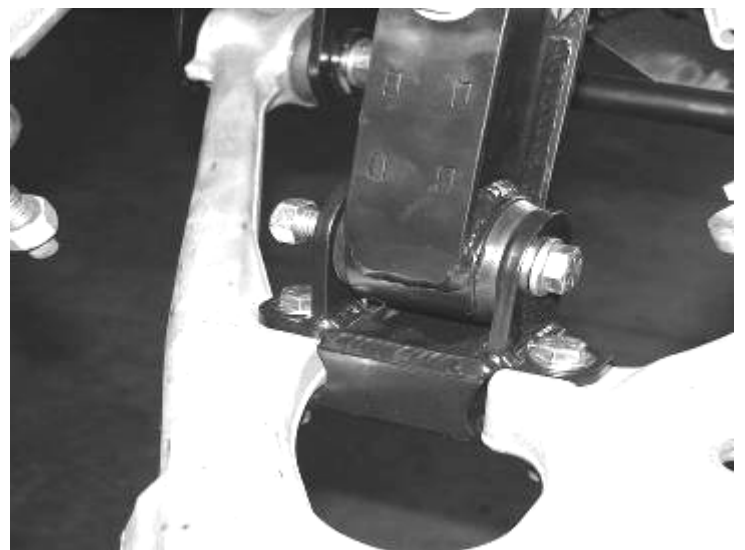

30. Locate the steering knuckle FT20276D and FT20276P. Attach the lower control arm to the knuckle using the stock hardware and torque to 70 ft lbs. Attach the upper control arm to the new knuckle using the factory hardware and torque to 35 ft lbs.

31. Reinstall axle shaft through new knuckle and torque axle nut to 150 ft lbs. and install bearing cover.

32. Locate and install the FT20289 CV spacers between the CV axle and the differential housing using 10mm x 50mm bolt and washer with the provided thread lock compound and torque to 55 ft lbs. in a cross pattern. SEE PHOTOS BELOW.

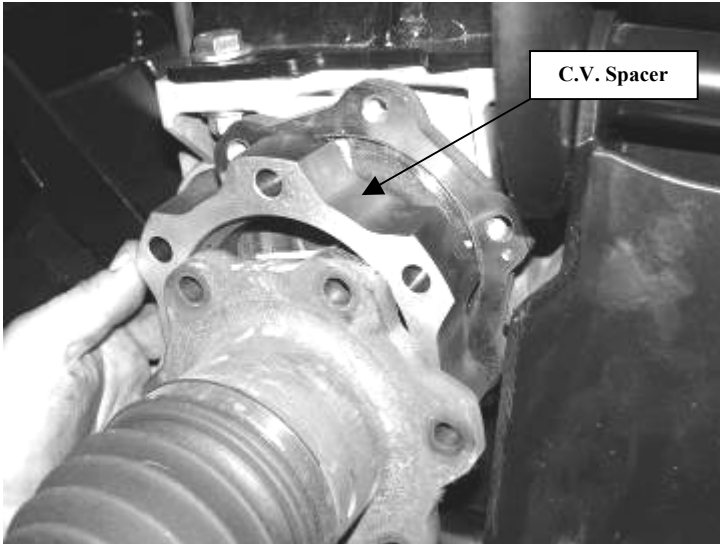

33. Reinstall the rotor and hub bearing assembly using the stock hardware and torque flange bolts to 125 ft lbs. Reinstall brake rotor and caliper. Torque caliper bolts to 30 ft lbs.

34. Locate FT20277 outer tie rods. Loosen the jam nut and remove the factory outer tie rods and discard, leaving the factory jam nut on the inner tie rod. Install the new outer tie rod onto the inner tie rod until it makes contact with the jam nut. Attach new tie rod end to the knuckle with the supplied nut and torque to 60 ft-lbs. **(This is just a starting point; a final alignment must be performed upon completion of suspension system).** SEE PHOTOS IN NEXT COLUMN

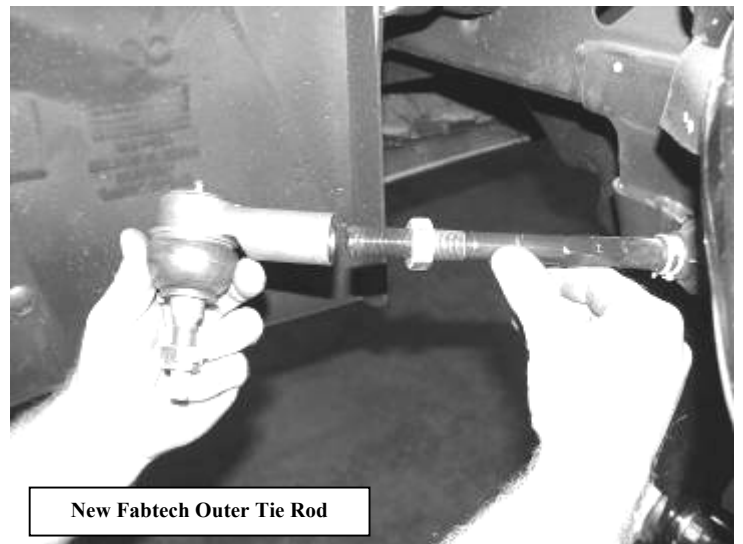
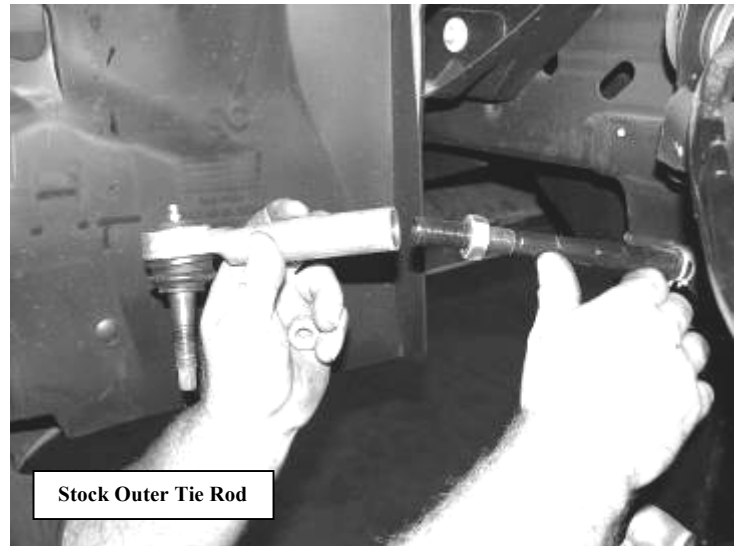

35. Locate FT20312 (Drv), FT20318 (Pass) Sway Bar Frame Bracket, and the supplied 7/16"x2 1/4" and 10mm x 30mm hardware. Position the frame bracket on the frame so that sway bar will be farther back from the suspension and attach with the 10mm hardware. Locate the factory sway bar with the factory mounts and attach to the new brackets with the 7/16" hardware and torque to 50 ft lbs. and the 10mm hardware to 25 ft lbs. SEE PHOTO BELOW

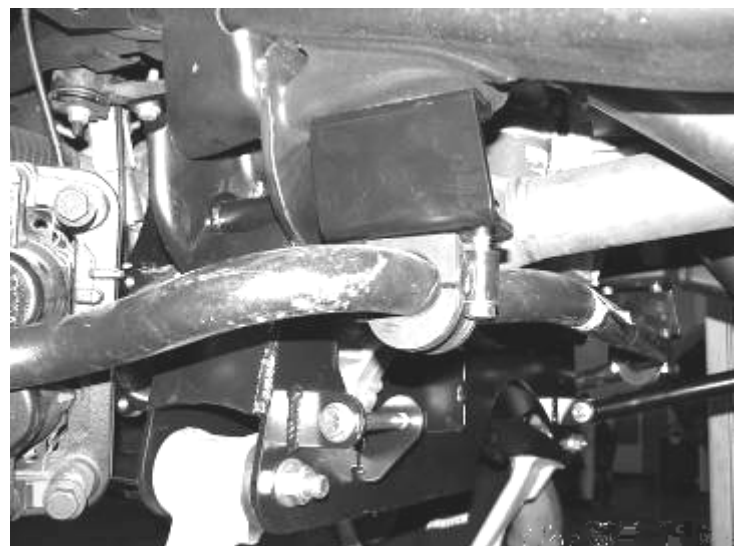

36. Locate FT20602 Sway Bar Mounts and the supplied 18mm x 50mm hardware. Position the Sway Bar Mount so that it is on the bottom of the sway bar with the stop plate on the bottom. Attach with the 18mm hardware and torque to 110 ft lbs. Locate the factory sway bar end links and attach to the new mount and the lower control arm. SEE PHOTOS BELOW.

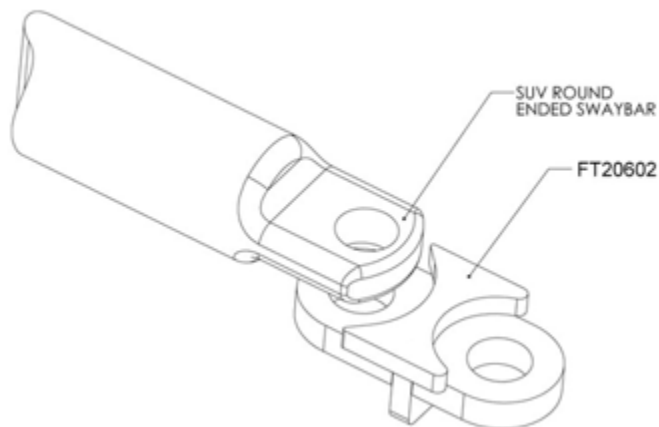

37. Locate FT20313 (drv.) FT20314 (pass) Brake Line Bracket and $\frac{1}{4}$ " x $\frac{3}{4}$ " hardware. Position the new bracket into the factory brake line bracket location and attach with the factory hardware and the $\frac{1}{4}$ " hardware. Attach the factory brake line bracket to the new Fabtech bracket. Carefully bend the hard brake line and attach with the supplied $\frac{1}{4}$ " hardware. Torque to 10 ft LBS. SEE PHOTOS IN NEXT COLUMN.

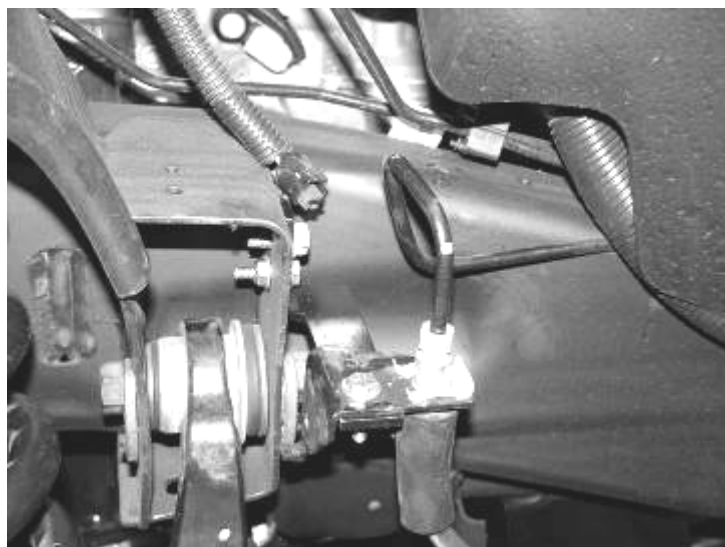
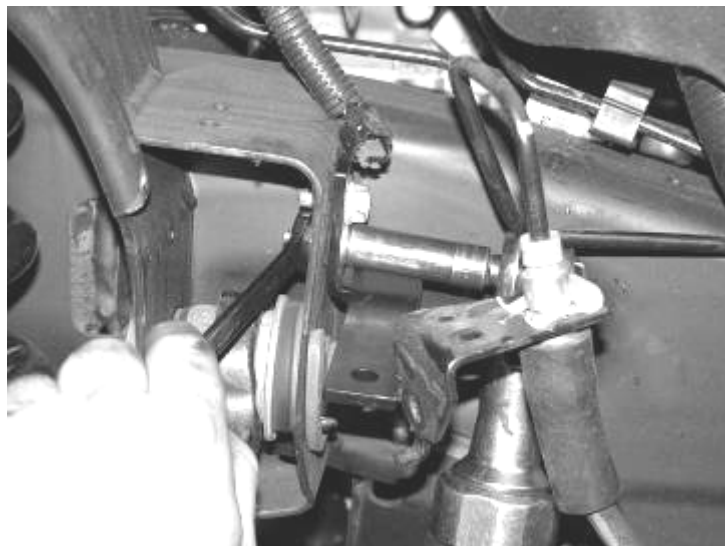
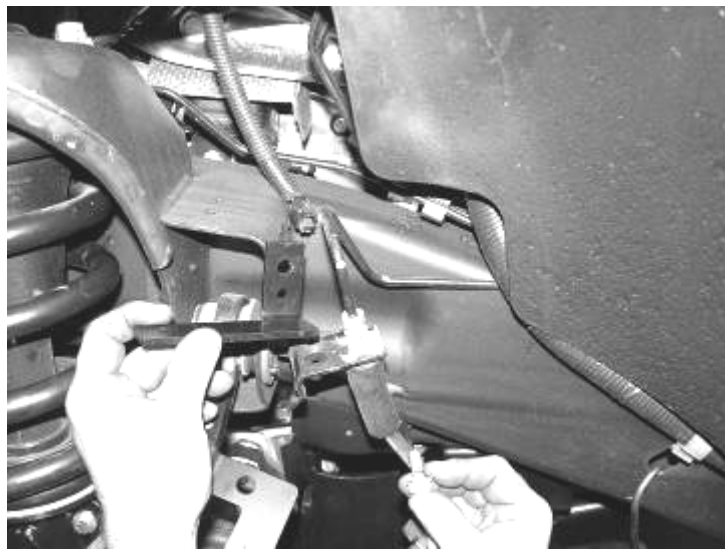

38. Re-route the brake hose and the ABS Line to the steering knuckle using the adel clamp to the back of the steering knuckle and attach with 1/4" x 3/4" bolt and washer. Torque to 10 ft LBS. Route the ABS line next to the brake hose. Re-connect the ABS line to the harness in the wheel well. Using provided plastic tyraps secure line to the hose and away from the tire and wheel. SEE PHOTO BELOW



39. Reattach the driveshaft to the differential yoke using the stock hardware and torque to 19ft lbs.
40. Locate the FT20288 Impact Strut Tube Mounts. Working from the drivers side, support the transmission crossmember and remove the two bolts that secure the crossmember to the frame. Position the new mount onto the front of the crossmember and insert the factory bolts into the new mount and then into the crossmember having the factory nut on the back of the crossmember. Torque to 75 lbs. SEE PHOTO IN NEXT COLUMN.



41. Locate and install the bushings into the Impact Strut bars. Attach the Impact Struts into the tabs on the back side of the lower control arm crossmember and rearward to the Impact Strut mounts using 7/16" x 3-1/2" bolts, nuts and washers from Hardware. ****NOTE** MAY NEED TO MODIFY EXHAUST TUBE ON SOME MODELS. REMOVE OXYGEN SENSOR BEFORE MODIFYING.** Torque to 45 ft lbs. SEE PHOTO BELOW



42. Install front tires and wheels. Torque lug nuts to wheel manufacturer's specifications. Check the brake and ABS lines for proper clearance from all moving items.
43. Check front end alignment and set to factory specifications. Adjust the headlights.

RETORQUE ALL NUTS, BOLTS AND LUGS AFTER 50 MILES AND PERIODICALLY THEREAFTER.

For technical assistance call: 909-597-7800

Product Warranty and Warnings-

Fabtech provides a Limited Lifetime Warranty to the original retail purchaser who owns the vehicle, on which the product was originally installed, for defects in workmanship and materials.

The Limited Lifetime Warranty excludes the following Fabtech items; bushings, bump stops, ball joints, tie rod ends, limiting straps, cross shafts, heim joints. These parts are subject to wear and are not considered defective when worn. They are warranted for 60 days from the date of purchase for defects in workmanship.

Take apart shocks are considered a serviceable shock with a one year warranty on leakage only. Service seal kits are available separately for future maintenance. All other shocks are covered under our Limited Lifetime Warranty.

Fabtech does not warrant any product for finish, alterations, modifications and/or installation contrary to Fabtech's instructions. Alterations to the finish of the parts including but not limited to painting, powdercoating, plating and/or welding will void all warranties. Some finish damage may occur to parts during shipping which is considered normal and is not covered under warranty.

Fabtech products are not designed nor intended to be installed on vehicles used in race applications or for racing purposes or for similar activities. (A "RACE" is defined as any contest between two or more vehicles, or any contest of one or more vehicle against the clock, whether or not such contest is for a prize). This warranty does not include coverage for police or taxi vehicles, race vehicles, or vehicles used for government or commercial purposes. Also excluded from this warranty are sales outside of the United States of America.

Installation of most suspension products will raise the center of gravity of the vehicle and will cause the vehicle to handle differently than stock. It may increase the vehicle's susceptibility to a rollover, on road and off road, at all speeds. Extreme care should be taken to operate the vehicle safely at all times to prevent rollover or loss of control resulting in serious injury or death. Fabtech front end Desert Guards may impair the deployment or operation of vehicles equipped with supplemental restraining systems/air bag systems and should not be installed if the vehicle is equipped as so.

Fabtech makes every effort to ensure suspension product compatibility with all vehicles listed in the catalog, but due to unknown auto manufacturers production changes and/or inconsistencies by the auto manufacturer, Fabtech cannot be responsible for 100% compatibility, including the fitment of tire and wheel sizes listed. The Tire and Wheel sizes listed in Fabtech's catalog are only a guideline for street driving with noted fender trimming. Fabtech is not responsible for damages to the vehicle's body or tires.

Fabtech's obligation under this warranty is limited to the repair or replacement, at Fabtech option, of the defective product only. All costs of removal, installation or re-installation, freight charges, incidental or consequential damages are expressly excluded from this warranty. Fabtech is not responsible for damages and/or warranty of other vehicle parts related or non related to the installed Fabtech product. This warranty is expressly in lieu of all other warranties expressed or implied. This warranty shall not apply to any product that has been subject to accident, negligence, alteration, abuse or misuse as determined by Fabtech.

Fabtech suspension components must be installed as a complete system including shocks as shown in our current catalog. All warranties will become void if Fabtech parts are combined and/or substituted with other aftermarket suspension products. Combination and/or substitution of other aftermarket suspension parts may cause premature wear and/or product failure resulting in an accident causing injury or death. Fabtech does not warrant products not manufactured by Fabtech.

Installation of Fabtech product may void the vehicles factory warranty; it is the consumer's responsibility to check with their local vehicle's dealer for warranty disposition before the installation of the product.

It is the responsibility of the distributor and/or the retailer to review all warranties and warnings of Fabtech products with the consumer prior to purchase.

Fabtech reserves the right to supercede, discontinue, change the design, finish, part number and, or application of parts when deemed necessary without written notice. Fabtech is not responsible for misprints or typographical errors within the catalog or price sheet.



INSTALLATION INSTRUCTIONS



2007-16 GM C/K1500 SUV 2WD/4WD 6" REAR SYSTEMS

FTS21051BK - REAR AUTORIDE COIL SPRING

FTS21052BK - REAR NON AUTORIDE COIL SPRING

FTS21160 - REAR COIL SPRING

Fabtech Motorsports | 4331 Eucalyptus Ave. Chino, CA 91710

Tech Line: 909-597-7800 | Fax: 909-597-7185 | Web: www.fabtechmotorsports.com

FTS21051BK		REAR COIL KIT (AUTORIDE)
2	FT1599-2BK	REAR COIL (AUTORIDE)
1	FT20292BK	TRAC BAR BRACKET
1	FT20307BK	TRAC BAR BRACKET SUPPORT
1	FT1599-2-2DBK	SHOCK DROP BRACKET (DRIVER)
1	FT1599-2-2PBK	SHOCK DROP BRACKET (PASSENGER)
1	FT20360BK	REAR UPPER LINK (DRIVER)
1	FT20361BK	REAR UPPER LINK (PASSENGER)
2	FT20362BK	LOWER LINK D/P
2	FT1599-2-4	REAR SWAY BAR END LINK
1	FT20299	BUSHING & SLEEVE KIT
1	FT20309	HARDWARE KIT
1	FT20319BK	REAR BUMP STOP BRACKET (DRIVER)
1	FT20320BK	REAR BUMP STOP BRACKET (PASSENGER)
	FT20821	HARDWARE SUBASSEMBLY
4	FT404739	SWAY BAR SLEEVE
4	FT20351	AUTORIDE FRONT SHOCK INSERTS
4	12008007100	8" BLACK ZIP TIE
4	12001407100	14" BLACK ZIP TIE
8	FT1004	SWAY BUSHING HALF
2	FT21051i	INSTRUCTION SHEET
1	FT20349	REAR BRAKE LINE BRACKET

FTS21160		REAR COIL KIT
2	FT20666BK	REAR COIL
1	FT20292BK	TRAC BAR BRACKET
1	FT20307BK	TRAC BAR BRACKET SUPPORT
1	FT1599-2-2DBK	SHOCK DROP BRACKET (DRIVER)
1	FT1599-2-2PBK	SHOCK DROP BRACKET (PASSENGER)
1	FT20360BK	REAR UPPER LINK (DRIVER)
1	FT20361BK	REAR UPPER LINK (PASSENGER)
2	FT20362BK	LOWER LINK D/P
2	FT1599-2-4	REAR SWAY BAR END LINK
8	FT1004	SWAY BUSHING HALF
4	FT404739	SWAY BAR SLEEVE
1	FT20319BK	REAR BUMP STOP BRACKET (DRIVER)
1	FT20320BK	REAR BUMP STOP BRACKET (PASSENGER)
1	FT20349	REAR BRAKE LINE BRACKET
1	FT20299	BUSHING & SLEEVE KIT
4	12008007100	8" BLACK ZIP TIE
4	12001407100	14" BLACK ZIP TIE
1	FT20309	HARDWARE KIT
2	FT21051i	INSTRUCTION SHEET
1	FT20819	HARDWARE SUBASSEMBLY

FTS21052BK		REAR COIL KIT (NON AUTORIDE)
2	FT20666BK	REAR COIL (NON AUTORIDE)
1	FT20292BK	TRAC BAR BRACKET
1	FT20307BK	TRAC BAR BRACKET SUPPORT
1	FT1599-2-2DBK	SHOCK DROP BRACKET (DRIVER)
1	FT1599-2-2PBK	SHOCK DROP BRACKET (PASSENGER)
1	FT20360BK	REAR UPPER LINK (DRIVER)
1	FT20361BK	REAR UPPER LINK (PASSENGER)
2	FT20362BK	LOWER LINK D/P
2	FT1599-2-4	REAR SWAY BAR END LINK
8	FT1004	SWAY BUSHING HALF
4	FT404739	SWAY BAR SLEEVE
1	FT20319BK	REAR BUMP STOP BRACKET (DRIVER)
1	FT20320BK	REAR BUMP STOP BRACKET (PASSENGER)
1	FT20349	REAR BRAKE LINE BRACKET
1	FT20299	BUSHING & SLEEVE KIT
4	12008007100	8" BLACK ZIP TIE
4	12001407100	14" BLACK ZIP TIE
1	FT20309	HARDWARE KIT
2	FT21051i	INSTRUCTION SHEET

FT20309 - HARDWARE KIT		LOCATION
1	9/16"-12 x 4" Bolt	REAR TRAC BAR BRACKET
1	9/16"-12 C-Lock Nut	
2	9/16" SAE Flat Washers	
2	7/16"-14 x 2 1/4" Bolt	
1	7/16"-14 x 1 1/2" Bolt	
3	7/16"-14 C-Locks	
6	7/16" SAE Flat Washer	
2	12mm x 1.75 x 75mm Bolt	REAR SWAY BAR LINKS @ BAR
2	12mm C-Lock Nut	
4	1/2" USS Flat Washer	
2	9/16"-12 x 3" Bolt	REAR SHOCK @ DROP BRACKET
2	9/16"-12 C-Lock Nut	
4	9/16" SAE Flat Washers	
1	5/16"-16 x 1" Bolt	REAR BRAKE LINE DROP
1	5/16"-16 C-Lock	
2	5/16" SAE Flat Washer	
4	3/8"-16 x 1 1/4" Bolt	BUMP STOP BRACKET
4	3/8"-16 C-Locks	
8	3/8" SAE Flat Washer	
2	1/4"-20 x 1" Bolt	AUTO RIDE DROP BRACKET
2	1/4"-20 C-Lock	
4	1/4" SAE Flat Washer	
8	1/4 Grease Fitting	ZERC FITTING
1	FTLube	BUSHING LUBE

FT20819		HARDWARE SUBASSEMBLY
8	FT1004	SWAY BUSHING HALF
4	FT404739	SWAY BAR SLEEVE
1	FT20349	REAR BRAKE LINE BRACKET
4	12008007100	8" BLACK ZIP TIE
4	12001407100	14" BLACK ZIP TIE
2	FT21051i	INSTRUCTION SHEET

- TOOL LIST -

Required Tools (Not Included)

Basic Hand Tools
Floor Jack
Jack Stands
Assorted Metric and S.A.E sockets, and Allen wrenches
Torque Wrench
Die Grinder w/ Cutoff Wheel or Sawzall

- PRE-INSTALLATION NOTES -

For technical assistance call: **909-597-7800** or e-mail: **info@fabtechmotorsports.com**

Read this before you begin installation-

Check all parts to the parts list above before beginning installation. If any parts are missing contact Fabtech at 909-597-7800 and a replacement part will be sent to you immediately.

Read all instructions thoroughly from start to finish before beginning the installation. If these instructions are not properly followed severe frame, driveline and / or suspension damage may occur.

Check your local city and state laws prior to the installation of this system for legality. Do not install if not legal in your area.

Prior to the installation of this suspension system perform a front end alignment and record. Do not install this system if the vehicle alignment is not within factory specifications. Check for frame and suspension damage prior to installation.

The installation of this suspension system should be performed by two professional mechanics.

This suspension must be installed with Fabtech shock absorbers.

Use the provided thread locking compound on all hardware.

WARNING- Installation of this system will alter the center of gravity of the vehicle and may increase roll over as compared to stock.

Vehicles that receive oversized tires should check ball joints, uniballs, tie rods ends, pitman arm and idler arm every 2500-5000 miles for wear and replace as needed.

Verify differential fluid is at manufactures recommended level prior to kit installation. Installation of the kit will reposition the differential and the fill plug hole may be in a different position. (For example, if the manufacture recommends 3 quarts of fluid, make sure the diff has 3 quarts of fluid). Check your specific manual for correct amount of fluid.

Due to variances vehicle may sit low in the rear. To achieve more lift order part number FTS21064 (1" spacer).

FOOTNOTES -

- 8. Will not fit all wheel drive models.
- 14. Cannot use OEM wheel and tire.
- 16. Utilizes stock rear shocks.
- 101. Some models may not sit level after install.
- 132. Will not fit 2WD Suburban models.
- 134. Will not fit 2WD Yukon XL models.

- INSTRUCTIONS -

REAR SUSPENSION

1. Disconnect the negative terminal on the battery. Jack up the front end of the truck and support the frame rails with jack stands. **NEVER WORK UNDER AN UNSUPPORTED VEHICLE!** Remove the front tires.
2. Disconnect the sway bar end links from the frame and sway bar, discard the endlinks, save the hardware. Remove the bolt securing the brake line support tab to the differential housing and save. Remove the ABS wiring from the frame mounts on both sides. Save all the hardware. **SEE FIGURE 1**



FIGURE 1 - STEP 2

3. Using a floor jack, raise the differential just enough to slightly compress the rear shocks. Remove the bolts securing the top of the shocks to the frame (if equipped with the Auto Ride System, unplug the electric and air line connections). Remove the lower pivot bolt that attaches the track bar to the axle bracket and save. **SEE FIGURE 2**



FIGURE 2 - STEP 3

4. Lower the floor jack to release the coil springs. Remove the coil springs from the vehicle and save the rubber upper and lower coil insulators

5. Support the rear axle with a floor jack and remove the factory lower links arms. Discard the links and save the hardware. **SEE FIGURE 3**



FIGURE 3 - STEP 5

6. Locate FT20319 (drv) & FT20320 (pass) Rear Bumpstop Brackets and the supplied 3/8"x1 1/4" hardware. Place the bump stop extension mounts onto the existing pads on the top of the differential. Using the 3/8" bolts, washers and C-lock nuts, secure the mount to the differential. There should be a flat washer on each side of the bolt. Do not fully tighten. Mark and drill the front 3/8" hole in the bumpstop and attach using the remaining 3/8" hardware on this new hole. Torque to 30 ft lbs. **SEE FIGURES 4-5**



FIGURE 4 - STEP 6



FIGURE 5 - STEP 6

7. Locate FT20360 (drv.) & FT20361 (pass) Rear Upper Link, FT20362 Rear Lower Links, and FT20299 Bushing and Sleeve Kit. Using an arbor press, press the bushings and sleeves (use supplied bushing lube) into each end of the links and install the supplied zerk fittings. On the upper links, use 2ea. FT1037 bushings and a short sleeve at each end. On the lower links, use (2) FT1038, and a long sleeve on each end.

8. Install the new Lower Link Arms into the factory rear axle mounts with the factory hardware. Then attach the arm to the frame mounts also with the factory hardware. Leave loose at this time. **SEE FIGURE 6**

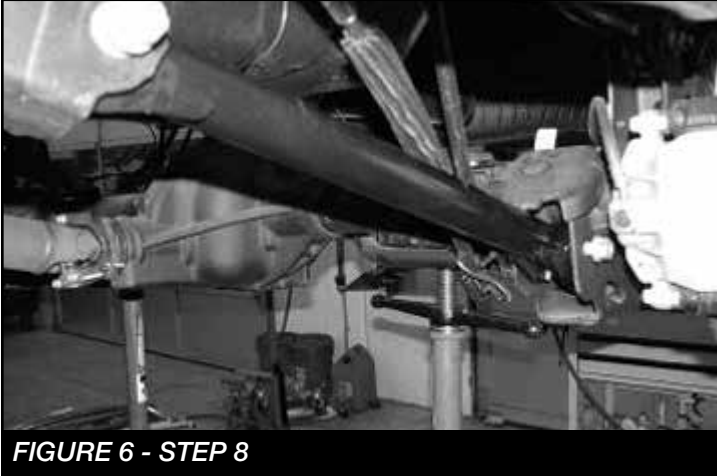

FIGURE 6 - STEP 8

9. Support the rear axle with a floor jack and remove the factory upper links arms. If the rear is equipped with Auto Ride, locate the Auto Ride sensors on both the driver side and passenger side of the vehicle on the upper link arms. Disconnect from the link arm and save with the hardware. **DO NOT REMOVE FROM THE TRUCK.** Discard the links and save the hardware. Install the new Upper Link Arms into the factory rear axle mounts with the factory hardware. (install / match the driver and passenger links as they were removed). Then attach the arm to the frame mounts also with the factory hardware. Remove the Auto Ride bracket from the position sensor and use a die grinder to remove the bottom of the bracket. Connect the auto ride brackets to the tabs on the upper links with the factory hardware. Leave the link arm bolts loose at this time. **NOTE:** Trim the last rib off the bumpstop. **SEE FIGURES 7-10**



FIGURE 7 - STEP 9



FIGURE 8 - STEP 9



FIGURE 9 - STEP 9



FIGURE 10 - STEP 9

10. Locate FT20292 Trac Bar Bracket, FT20307 Trac Bar Bracket Support, and the 7/16" & 9/16" hardware. Position the trac bar bracket into the factory mount on the axle and install with the factory bolt and hardware. Leave loose. Locate the two factory holes just forward of this mount, Using a drill with a 7/16" bit, drill these two holes out to 7/16" (carefully bend the brake line back from the inner hole). Position the support bracket over the two new holes and install with the 7/16" x 2 1/4" bolts and hardware. Insert the 9/16" x 4" bolt into the trac bar bracket and support bracket (tighten just enough to make the bracket and support make contact, over tightening without the trac bar installed will collapse the bracket) Torque the 7/16" bolts to 50 lbs. **SEE FIGURES 11-12**



FIGURE 11 - STEP 10

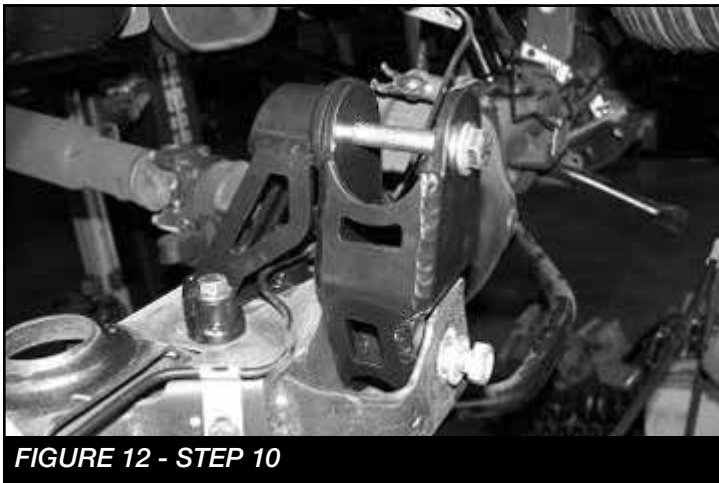

FIGURE 12 - STEP 10

11. Using a drill with a 7/16" bit, drill the hole on the new trac bar bracket to the factory mount. Use 7/16 x 1 1/2" bolt and hardware to attach the bracket to the mount and torque to 50 lbs. **SEE FIGURES 13-14**

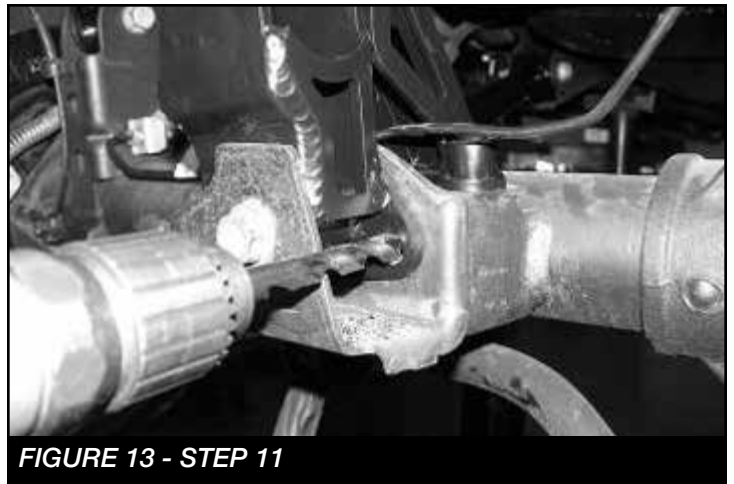

FIGURE 13 - STEP 11



FIGURE 14 - STEP 11

12. Working from the driver's side, locate FT1599-2-2D Shock Drop Bracket. Slide the shock mount extension into the original frame mount and insert one of the factory shock bolts and hardware through the original shock mount side and hand tighten. Take one of the new sway bar links and insert 2 bushing halves and a sleeve into each end (use the supplied lube). Install one end of the end link into the frame mount and insert the original bolt through the sleeve, (the factory hole may have to be drilled out with a 1/2" drill bit to align properly) securing the shock mount drop bracket. Torque the factory bolt to 75lbs and the upper bolt shock bolt to 85lbs. **SEE FIGURES 15-16**



FIGURE 15 - STEP 12



FIGURE 16 - STEP 12

IF YOU ARE INSTALLING DIRT LOGIC REAR SHOCKS, YOU WILL NOT USE THE FABTECH SHOCK DROP BRACKETS. THE DIRT LOGIC SHOCKS WILL MOUNT DIRECTLY INTO THE FACTORY UPPER AND LOWER SHOCK MOUNTS

13. Repeat step 12 on the passenger side of the truck.
14. Place a floor jack under the rear axle. Attach your coil spring compressor onto the new rear coil spring and compress the coil 1"-2". Set the upper coil insulator on top of the coil spring and position the top of the coil into the frame pocket. Push the bottom of the coil spring onto the axle pad and raise the floor jack under the axle to hold the coil spring in position. Remove the coil spring compressors. Repeat this with the opposite coil spring. On 2015 models use FT20666BK spring. **USE CAUTION WHEN WORKING WITH COIL SPRING COMPRESSORS, THEY CAN BE UNDER EXTREME LOAD. SEE FIGURES 17-18**

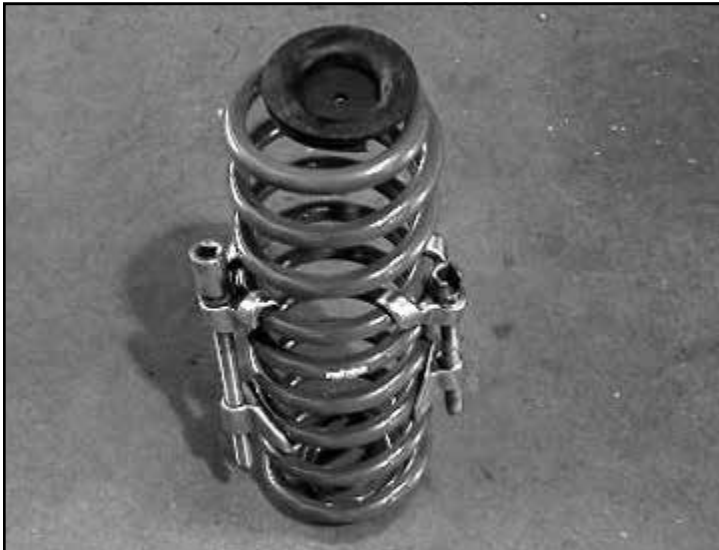

FIGURE 17 - STEP 14



FIGURE 18 - STEP 14

TRUCKS EQUIPPED WITHOUT AUTORIDE, FOLLOW STEP FIFTEEN, SKIP STEP SIXTEEN - EIGHTEEN

TRUCKS EQUIPPED WITH AUTORIDE, FOLLOW STEP SIXTEEN - EIGHTEEN AND SKIP STEP FIFTEEN

15. Reinstall the factory shocks onto the lower axle mounts with the factory hardware and into the new dropped upper mount using the supplied 9/16" x 3". Torque to 75 lbs. **SEE FIGURE 19**



FIGURE 19 - STEP 15

16. Working from the driver's side, electrical plug. Follow the electrical plug to the plastic loom, carefully open the loom and **ONLY** remove the ABS wires from it back approximately 10 inches. Route the plug and line down to the shock and plug in. **SEE FIGURE 20**



FIGURE 20 - STEP 16

17. Remove the air line manifold from its connection point in the rear wheel well. Bring the manifold forward just behind the rear shock. The supply line needs to be swapped on the manifold with the line to the driver side shock. Remove the clips from the ends and swap the two lines. Use a drill with a 15/64" drill bit and drill a hole into the plastic liner and insert the manifold into it. Use two of the supplied 8" zip ties and attach the ABS & Electrical lines to the shock extension. Use two of the supplied 14" zip ties and attach the ABS line to the shock ABOVE THE SHOCK BLADDER. **SEE FIGURES 21-28**

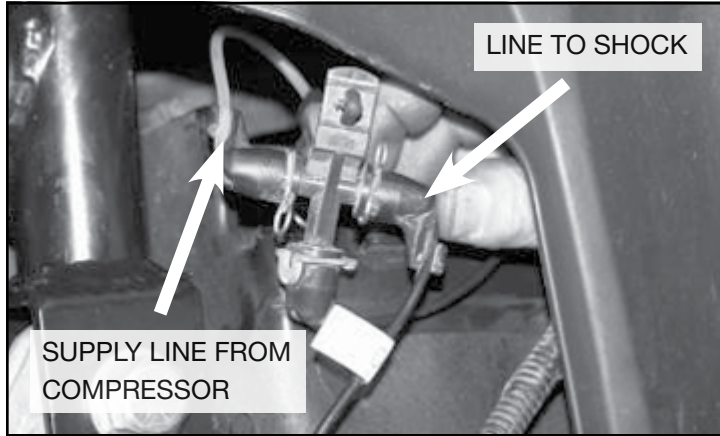

FIGURE 21 - STEP 17 (FACTORY ROUTING SHOWN)

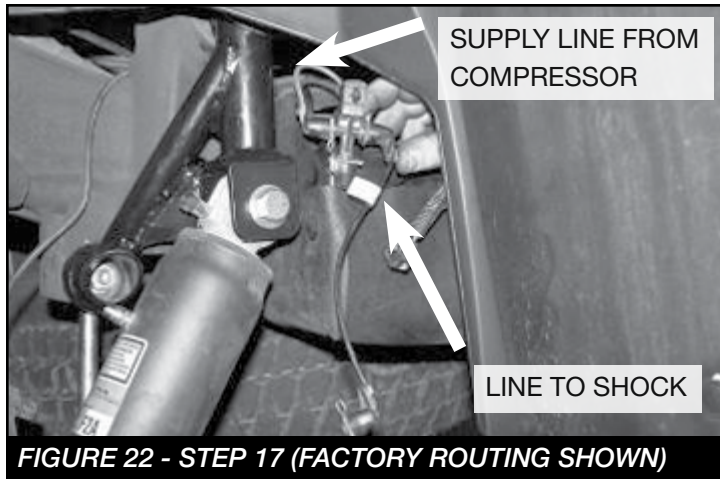

FIGURE 22 - STEP 17 (FACTORY ROUTING SHOWN)

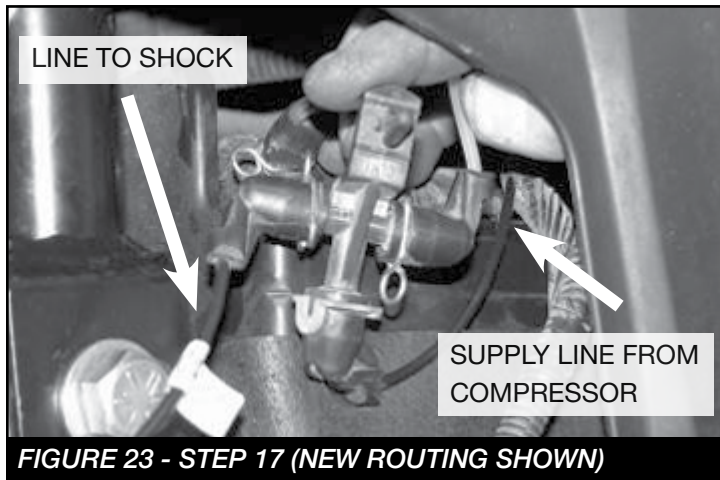

FIGURE 23 - STEP 17 (NEW ROUTING SHOWN)

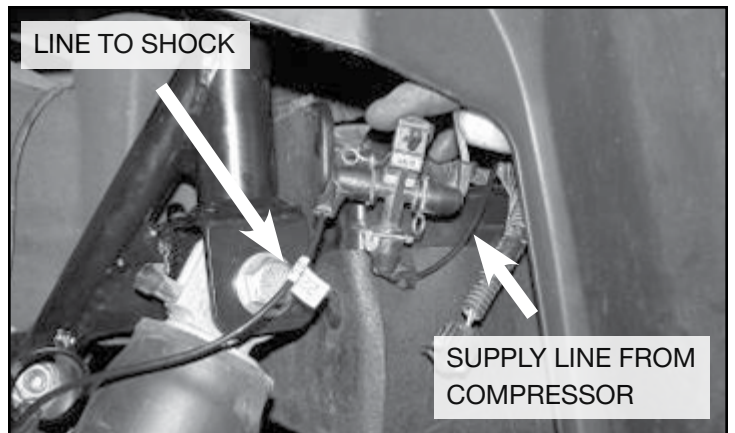

FIGURE 24 - STEP 17 (NEW ROUTING SHOWN)



FIGURE 25 - STEP 17

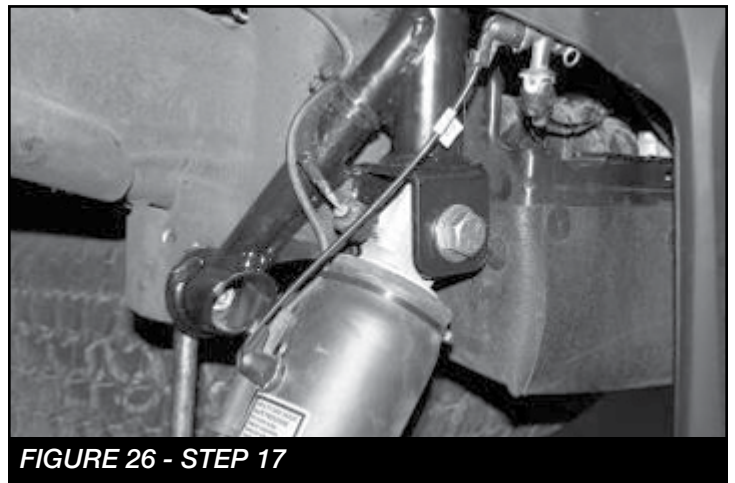

FIGURE 26 - STEP 17



FIGURE 27 - STEP 17



FIGURE 28 - STEP 17

18. Repeat steps sixteen and seventeen on the passenger side (there is no air line manifold on the passenger side)
19. Remove the 9/16" x 4" bolt from the trac bar bracket and install the trac bar into the bracket (some trucks require sanding the edge / flashing off of the end of the trac bar for fitment into the new bracket). Torque to 75 lbs. At this time torque the control arm bolts to 127 ft-lbs.
SEE FIGURE 29



FIGURE 29 - STEP 19

20. Connect the bottom of the sway bar end link onto the sway bar using the supplied 12mm-1.75 x 75 bolts, 1/2" large flat washers and nylock nuts. Install the brake line extension tab using the original bolt and the supplied 5/16" hardware. **SEE FIGURES 30-31**

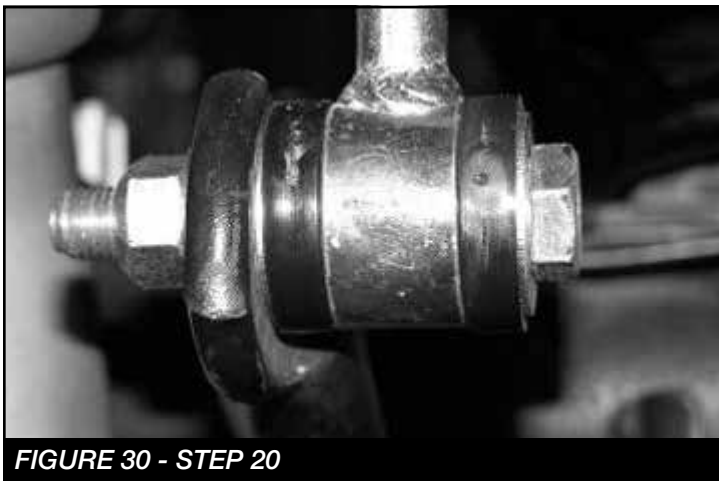

FIGURE 30 - STEP 20

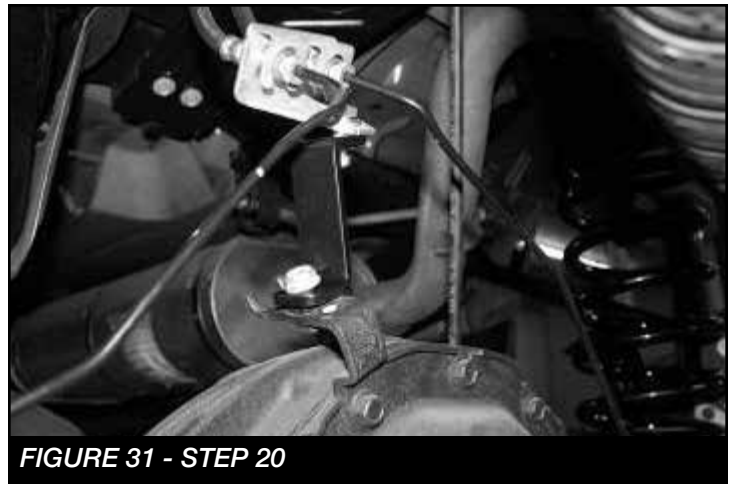

FIGURE 31 - STEP 20

21. Install tires and wheels and torque lug nuts to wheel manufacturer's specifications. Turn front tires left to right and check for appropriate tire clearance. **Note - Some oversized tires may require trimming of the front bumper & valance.**
22. Check front end alignment and set to factory specifications. Readjust headlights.
23. Recheck all bolts for proper torque.
24. Recheck brake hoses, ABS wires and suspension parts for proper tire clearance while turning tires fully left to right.
25. Check the fluid in the front and rear differential and fill if needed with factory specification differential oil. **Note - some differentials may expel fluid after filling and driving. This can be normal in resetting the fluid level with the new position of the differential/s.**
26. Install Driver Warning Decal. Complete product registration card and mail to Fabtech in order to receive future safety and technical bulletins on this suspension.
27. Have vehicle properly aligned to factory specs.

Vehicles that will receive oversized tires should check ball joints, uniballs and all steering components every 2500-5000 miles for wear and replace as required.

RETORQUE ALL NUTS, BOLTS AND LUGS AFTER 50 MILES AND PERIODICALLY THEREAFTER.

For technical assistance call: **909-597-7800**

- Product Warranty and Warnings -

Fabtech provides a Limited Lifetime Warranty to the original retail purchaser who owns the vehicle, on which the product was originally installed, for defects in workmanship and materials.

The Limited Lifetime Warranty excludes the following Fabtech items; bushings, bump stops, ball joints, tie rod ends, limiting straps, cross shafts, heim joints and driveshafts. These parts are subject to wear and are not considered defective when worn. They are warranted for 60 days from the date of purchase for defects in workmanship.

Dirt Logic and Performance Coilover take apart shocks are considered a serviceable shock with a one year warranty on leakage only. Service seal kits are available separately for future maintenance. All other shocks are covered under our Limited Lifetime Warranty.

Fabtech does not warrant any product for finish, alterations, modifications and/or installation contrary to Fabtech's instructions. Alterations to the finish of the parts including but not limited to painting, powder coating, plating and/or welding will void all warranties. Some finish damage may occur to parts during shipping, which is considered normal and is not covered under warranty.

Fabtech products are not designed nor intended to be installed on vehicles used in race applications or for racing purposes or for similar activities. (A "RACE" is defined as any contest between two or more vehicles, or any contest of one or more vehicle against the clock, whether or not such contest is for a prize). This warranty does not include coverage for police or taxi vehicles, race vehicles, or vehicles used for government or commercial purposes. Also excluded from this warranty are sales outside of the United States of America.

Installation of most suspension products will raise the center of gravity of the vehicle and will cause the vehicle to handle differently than stock. It may increase the vehicle's susceptibility to a rollover, on road and off road, at all speeds. Extreme care should be taken to operate the vehicle safely at all times to prevent rollover or loss of control resulting in serious injury or death. Fabtech front end Desert Guards may impair the deployment or operation of vehicles equipped with supplemental restraining systems/air bag systems and should not be installed if the vehicle is equipped as so.

Fabtech makes every effort to ensure suspension product compatibility with all vehicles listed on the website, but due to unknown auto manufacturer's production changes and/or inconsistencies by the auto manufacturer, Fabtech cannot be responsible for 100% compatibility, including the fitment of tire and wheel sizes listed. The Tire and Wheel sizes listed in Fabtech's website are only a guideline for street driving with noted fender trimming. Fabtech is not responsible for damages to the vehicle's body or tires. Fabtech is not responsible for premature wear of factory components due to the installation of oversized tires and wheels.

Fabtech's obligation under this warranty is limited to the repair or replacement, at Fabtech option, of the defective product only. All costs of removal, installation or re-installation, freight charges, incidental or consequential damages are expressly excluded from this warranty. Fabtech is not responsible for damages and/or warranty of other vehicle parts related or non related to the installed Fabtech product. This warranty is expressly in lieu of all other warranties expressed or implied. This warranty shall not apply to any product that has been subject to accident, negligence, alteration, abuse or misuse as determined by Fabtech.

Fabtech suspension components must be installed as a complete system including shocks as shown on our website. All warranties will become void if Fabtech parts are combined and/or substituted with other aftermarket suspension products. Combination and/or substitution of other aftermarket suspension parts may cause premature wear and/or product failure resulting in an accident causing injury or death. Fabtech does not warrant products not manufactured by Fabtech.

Depending on the condition of the factory suspension components retained after the installation of a Fabtech suspension not all vehicles may have the same ride stance front to rear as described in the website. The blue color of suspension components shown in all Fabtech photographs are for display purposes only. Majority of all Fabtech components will be black specifically where noted with part numbers ending in BK.

Installation of Fabtech product may void the vehicles factory warranty; it is the consumer's responsibility to check with their local vehicle's dealer for warranty disposition before the installation of the product. Some state laws may prohibit modification of suspension to a vehicle in whole or in part. It is the responsibility of the installer and consumer to consult local laws prior to the installation of any Fabtech suspension product to comply with such written laws.

It is the responsibility of the distributor and/or the retailer to review all warranties and warnings of Fabtech products with the consumer prior to purchase.

Fabtech reserves the right to super cede, discontinue, change the design, finish, part number and/or application of parts when deemed necessary without written notice. Fabtech is not responsible for misprints or typographical errors within the website or price sheet. For the most recent Product Warranty and Warnings visit our website www.fabtechmotorsports.com