

Any damaged or missing parts?

Parts will be shipped to you directly.

Call 800-877-2588, Mon - Fri, 8:30 a.m. - 6:00 p.m. EST

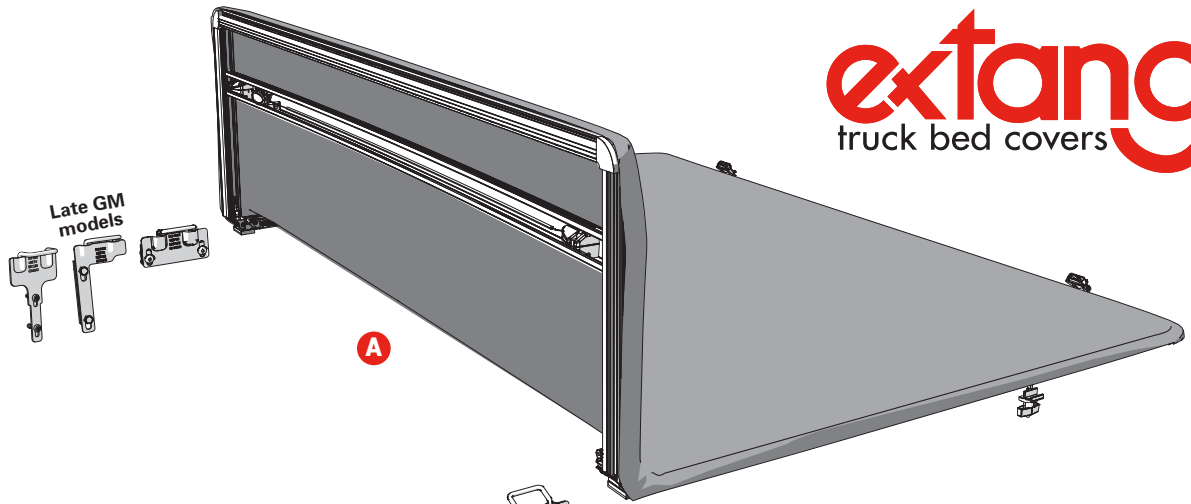

TOOLS PROVIDED

- Torx wrench - T-20
- Torx wrench - T-27
- Hex wrench - 2.5MM

TOOLS REQUIRED

- Tape measure
- Pliers
- Knife or cutting tool
- Torx wrench - T-30 (*Maverick only*)
- Socket or wrench - 1/2" (*GM*)

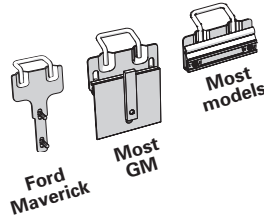

PARTS THAT MAY BE INCLUDED IN YOUR KIT

- A** Cover assembly
- B** 4x T-27 Torx screws
- C** 2x Striker brackets (*Most models*)
- D** 4x Weld nuts
- E** 2x Backing plates
- F** 2x Striker brackets (*Maverick only*)
- G** 1x Tap plate, 2 holes
- H** 1x Rear striker bracket (*2019+ GM, drivers side only*)
- I** 2x Bolts - 5/16" - 18 x 1"
- J** 2x Nuts - 5/16"
- K** 2x Bolts - 5/16" - 18 x .625"
- L** 2x Bolts - 5/16" - 18 x 1"
- M** 2-4x Flat washers (*based on model year*)
- N** 1-2x Backing plates (*based on model year*)
- O** 1-2x Tap plates, 1 hole (*based on model year*)
- P** 1-2x Striker brackets (*based on model year*)

MOST MODELS

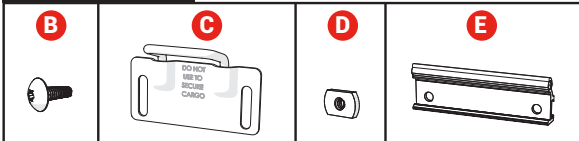

Components B-E come pre-assembled

FORD MAVERICK



MOST GM

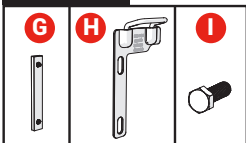

Components G-I come pre-assembled

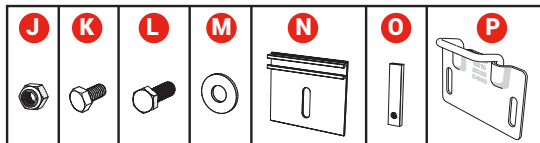

Components J-P come pre-assembled

1 Place the folded, assembled bed cover (A) over the cab end of the truck box.

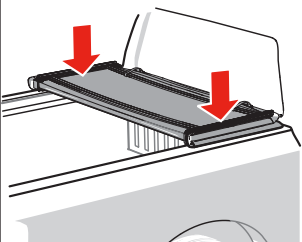

2 Unfold the bed cover (A) fully and adjust position over the truck bed for proper front (cab) and rear (tailgate) alignment. When positioned front and back, the tailgate seal should contact the tailgate with the first two fins.

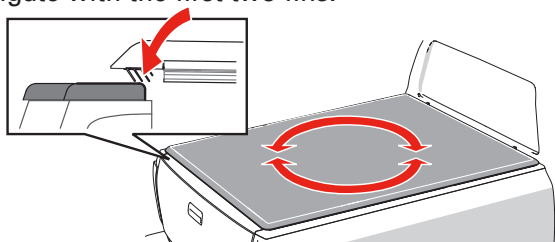

3 Carefully re-fold the bed cover (A) without shifting its position on the truck bed. **Note** the position of the front clamp for trimming the bed cap in step 4.

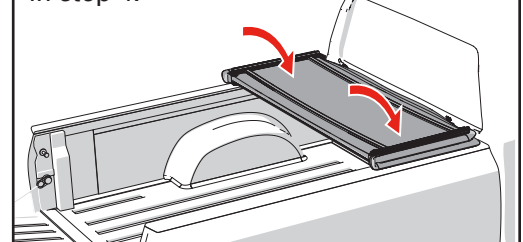

4



If your truck has a plastic bed rail cap that extends below the truck sheet metal bed flange, you **MUST** remove enough of the plastic so that the clamps make solid contact with the truck's sheet metal.

This is commonly found on 04-14 & 21 Ford F150s and 09-19 RAMs, but your specific vehicle should be inspected carefully to ensure a proper installation.

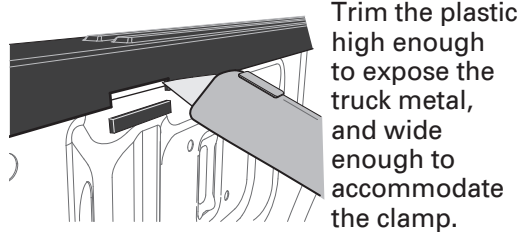
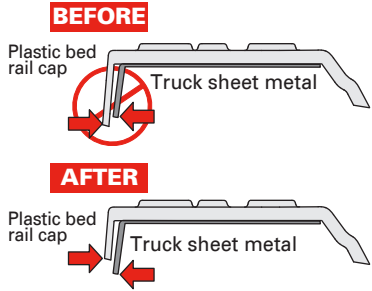

Do NOT cut into or scrape the truck bed.

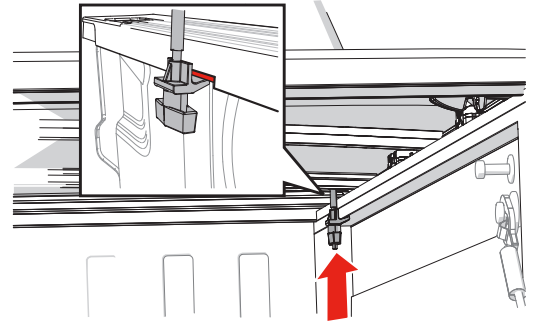

5

Slide the cab clamps over to the truck bed rail. Hook the clamp jaw under the truck bed rail.

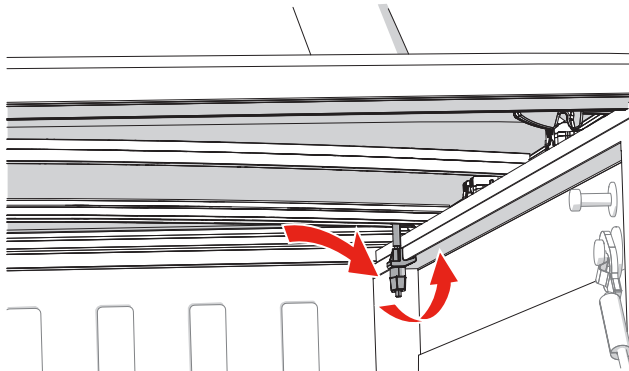

Hand tighten the clamps to hold the cover in position.

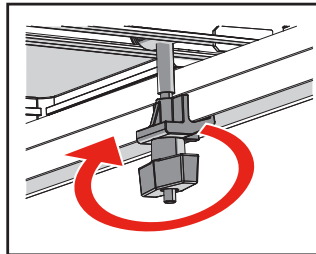

6

With the tailgate open and the front (cab) clamps secure, completely close the bed cover (A).

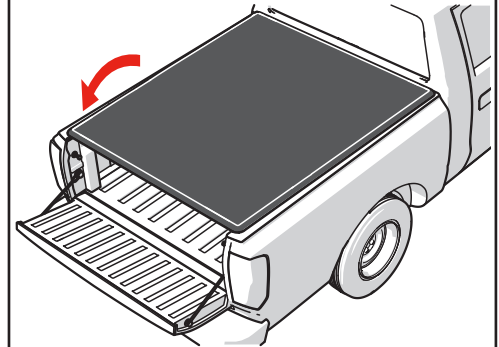

7

• Most models

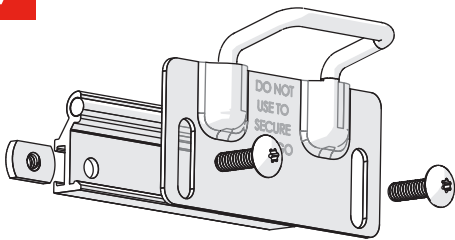

The brackets are assemblies comprised of the striker bracket (C), T-27 Torx screws (B), a backing plate (E) and a weld nut (D).

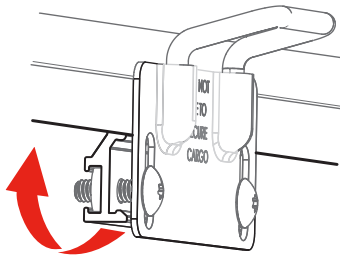

With the truck bed cover (A) closed, attach the striker brackets (C) to the metal truck bed rail.

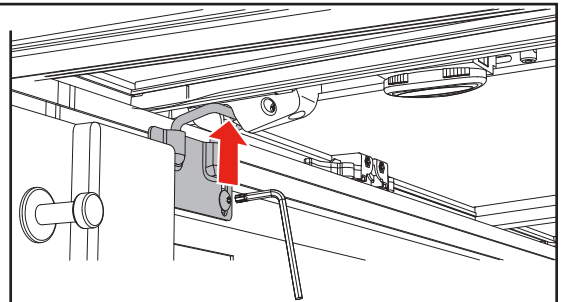

Align the striker brackets (C) so that the bracket loop aligns with and firmly latches into the cover latch assembly (see step 8 for latch assembly adjustment). Attach to both driver and passenger sides. Using the provided T-27 Torx wrench, tighten the screws firmly while continuing to align the latches in later steps.

7A • Chevy/GMC Silverado/Sierra 1500 (5ft 8in, 6ft 6in) 2019-22, "New Body Style" - **DRIVER SIDE ONLY**

If a drop-in bedliner is installed, clearance holes will need to be added to the bedliner to accept the striker bracket fasteners.

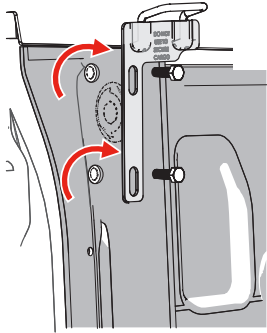

Trucks **WITHOUT** the MultiPro/Multi-Flex tailgate and assist handle

Trucks **WITH** the MultiPro/Multi-Flex tailgate and assist handle

Insert the tap plate (G) down through the stake pocket opening and align with the 5/16" - 18 x 1" (I) while installing the striker bracket (H).

Utilize the assist handle mounting studs and the original nuts to mount the striker bracket (H). After the final bracket adjustment in step 10, the original nuts should be tightened to 30 Nm, 22 ft-lb.

NOTE:
A pair of pliers can help hold the nut plate when installing.

In both cases, the bolts or nuts will be tightened after the final bracket adjustment in step 10.

7B • Chevy/GMC Canyon/Colorado (5ft & 6ft beds) 2015-22 - **DRIVER & PASSENGER SIDES**
 • Chevy/GMC Silverado/Sierra 1500 (5ft 8in, 6ft 6in) 2014-18 - **DRIVER & PASSENGER SIDES**
 • Chevy/GMC Silverado/Sierra 2500/3500HD 2015-18 - **DRIVER & PASSENGER SIDES**
 • Silverado 1500 Legacy & Sierra 1500 Limited 2019 - **DRIVER & PASSENGER SIDES**
 • Chevy/GMC Silverado/Sierra 1500 (5ft 8in, 6ft 6in) 2019-22, "New Body Style" - **PASSENGER SIDE ONLY**

Insert the tap plate (O) down through the stake pocket opening and align with the flat washer (M) and 5/16" - 18x1" bolt (L) through the bed wall hole while installing the striker bracket (P).

NOTE: The bed wall hole plug will have to be removed.

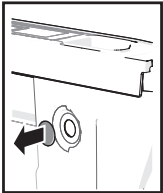

NOTE:
A pair of pliers can help hold the nut plate when installing.

The tap plate (O) lowers into the pocket and up under the plastic cap edge. Thread the 5/16" - 18x1" bolt (L) through the washer (M), bracket (P) slot and into the (O) tap plate.

Slide the backing plate (N) up until it contacts the bottom of the bed cap. Tighten the 5/16" - 18x1" bolt (L).

Tighten the 5/16" nuts (J) after the final adjustment in step 10.

7c • Ford Maverick - **DRIVER & PASSENGER SIDES**

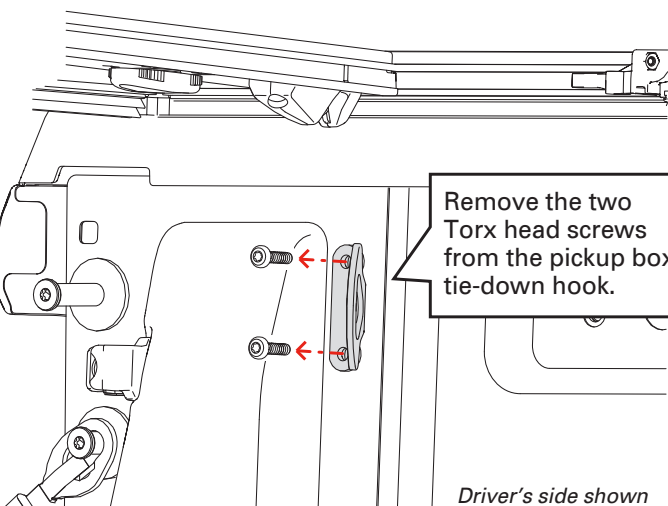

Remove the two Torx head screws from the pickup box tie-down hook.

Driver's side shown

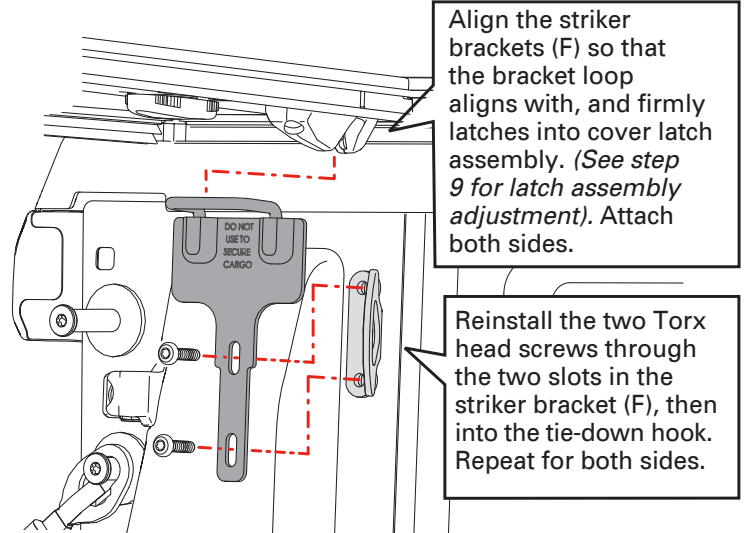

Align the striker brackets (F) so that the bracket loop aligns with, and firmly latches into cover latch assembly. (See step 9 for latch assembly adjustment). Attach both sides.

Reinstall the two Torx head screws through the two slots in the striker bracket (F), then into the tie-down hook. Repeat for both sides.

8 Adjustments and tightening of the latch assembly is required.

The bed cover latch assemblies and rotary knob come from the factory only partially tightened to allow for installation adjustments. Both latches and rotary knob will require adjustment and final tightening. **Only use the hand tools provided, do not use power tools.**

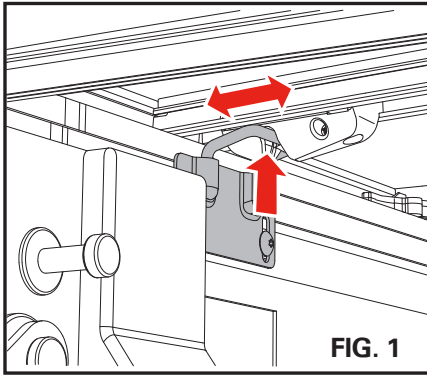

Lower the rear of the bed cover and adjust the position of each latch so that they engage with the striker brackets, (Fig. 1). With the latches adjusted, from underneath the cover, use the provided T-20 Torx wrench to tighten the two screws, (Fig. 2) in both the driver and passenger side latches.

The cable from the driver's side latch comes routed through the barrel clamp of the actuator and hangs out. Slide the actuator so that 3/4" - 1" (19.1 - 25.4mm) of cable extends through the barrel clamp, (Fig. 3).

Rotate the actuator knob until you see the flat head screws. Tighten the two flat head screws using the provided T20 hex wrench, (Fig. 3).

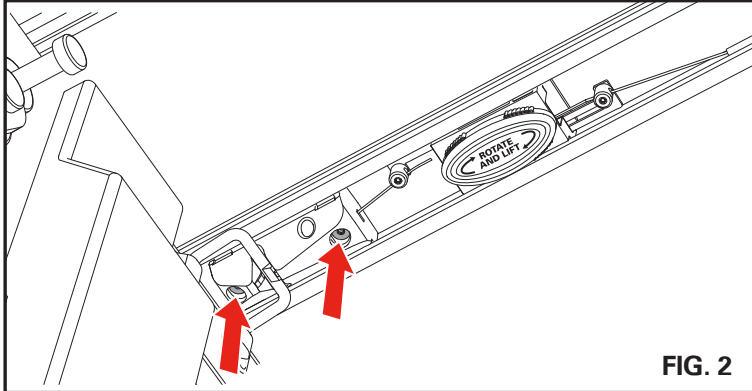

The cable from the passenger side latch comes routed through the other barrel clamp of the actuator. Excess cable length is routed through the middle of the actuator assembly (above the bottom plate below the plastic housing). Do not trim the excess cable, leave it for future adjustments, (Fig. 3).

Next, tighten the barrel clamps, (Fig. 4) with the provided 2.5mm hex key to secure the latch cables. Rotate the actuator knob, (Fig. 4) to verify that the latches disengage from the striker brackets.

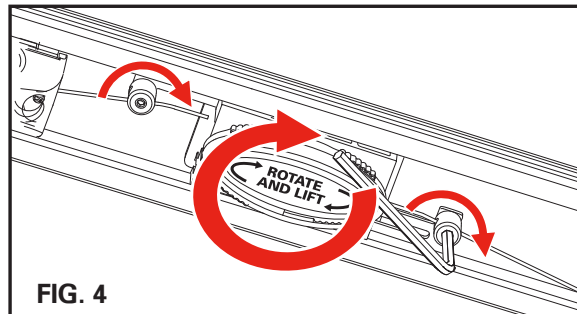
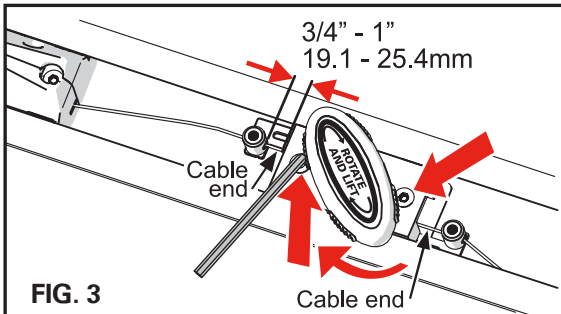

Double-check that the cover is secure and tight to the truck bed by gently lifting the corners to ensure the mechanisms are engaged.

9 To make the final adjustment, loosen the striker bracket bolts or screws. Then move the bracket (C, F, H, or P) down by firmly pushing the cover (A) or pulling the rear bow down to the truck rail and tailgate. Make sure that both sides match, then retighten all the screws.

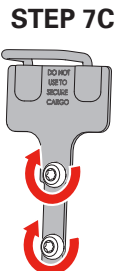
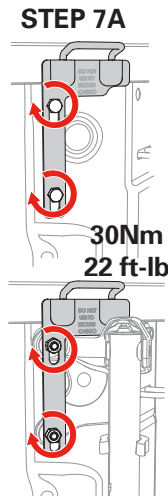
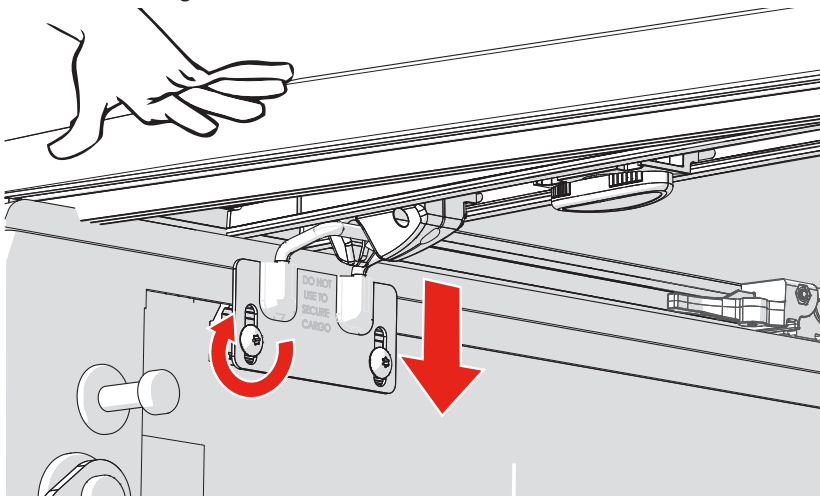

10 The tethers come installed looped over the bed cover bow with a clamp at the other end. Install the clamp end by sliding the clamp onto the truck rail. Make sure the clamp is positioned as far up onto the rail as possible. Firmly hand tighten the knobs. Install the tethers on both sides of the cover.

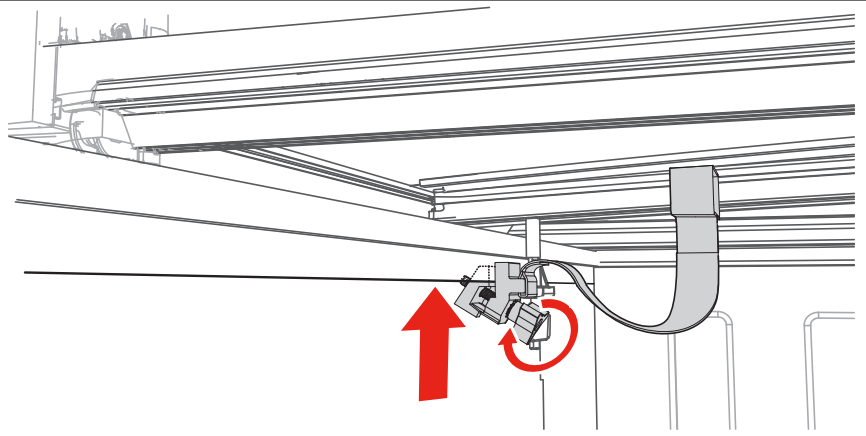

Opening the cover

Open the cover by twisting the actuator knob and lifting the cover.

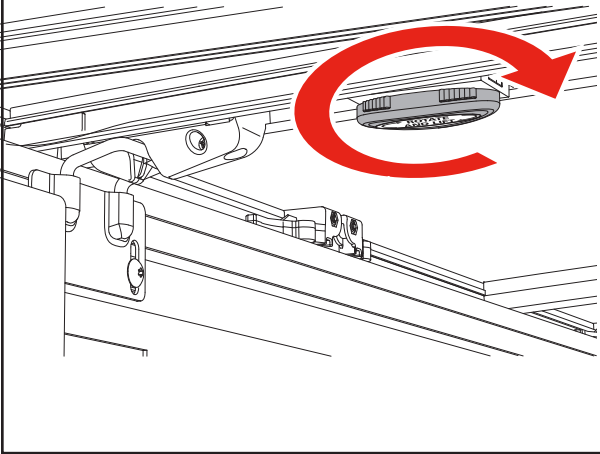

Securing the cover

To drive with the cover open, fold the cover forward to the cab and fasten BOTH straps in the middle section to the front rail. Check that the straps are tight, and pull the strap end if too loose.

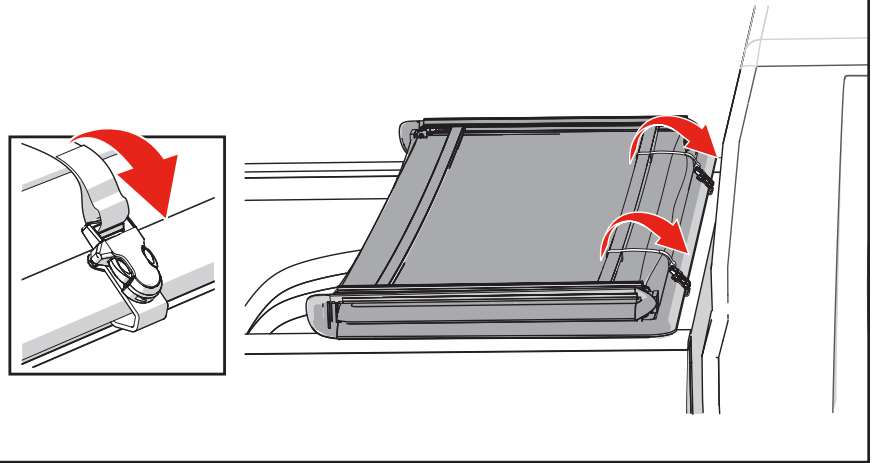

IMPORTANT

Re-tighten the front/cab clamps and tethers after the first week of driving the vehicle. Also periodically check the clamps and tethers to ensure they are secure.

Closed/Extended Position – Bed cover must be completely secured by all four (4) clamps.

Open/Folded Position – Bed cover must be completely folded up (all panels) and secured at the cab with the provided buckles straps and with both tethers attached.

Do NOT drive with the bed cover in a partially open position.

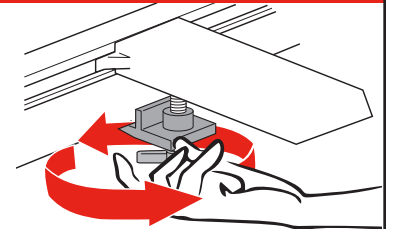

Do NOT allow the vehicle to be towed backwards without first removing the cover from the vehicle.



Remove any snow or foreign matter before folding the bed cover.

REPLACEMENT PARTS

Replacement parts can be ordered online at extang.com/replacement-parts or you can contact our Customer Service Department for assistance. When ordering, xxx represents the 3 digit suffix, as referenced on the sales receipt or vehicle application list.

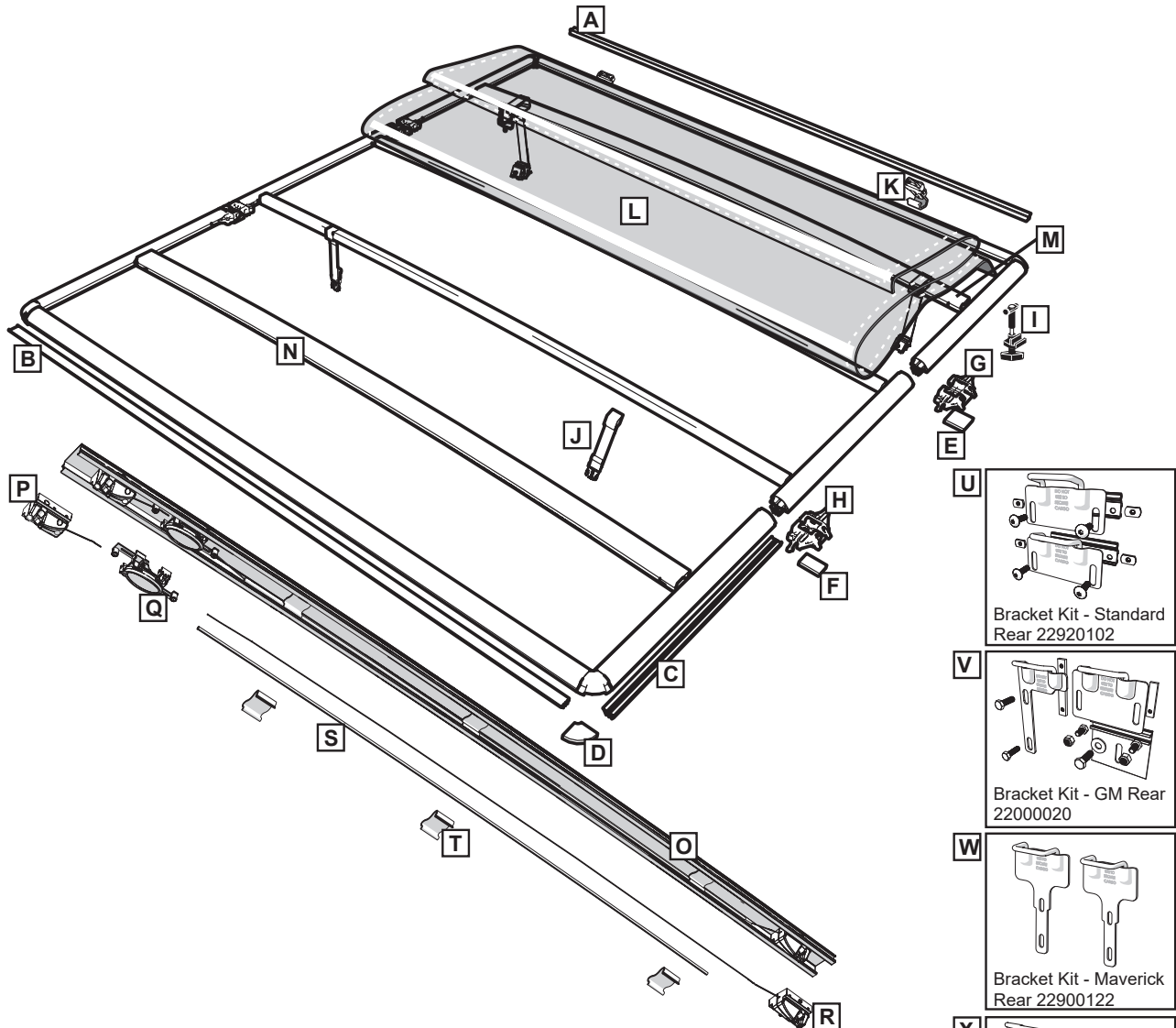

Call Out	Title	Part Number	Description	Qty
A	Cab Seal	32002112	Single length seal (6'), hollow seal, cut to fit	1
B	Tailgate Seal	32563200	Single length seal, (68"), 4-fin, cut to fit	1
C	Side Rail Seal	32560368	Single length (68") Side Seal, one length will fit two panel sides, cut to fit, (there are 6 sides per cover). Two seals for 6' beds, three for longer beds.	1
D	Corner Seal	32440100	Measure for thickness- 0.375", 0.5", 0.75"	1
E	Hinge Seal, Cab	32920104	Seal only	1
F	Hinge Seal, Tail	32920102	Seal only	1
G	Cab Hinge	31442015	Seal not included, see item Hinge Seal, Cab (E)	1
H	Tail Hinge	31442005	Seal not included, see item Hinge Seal, Tail (F)	1
I	Cab Clamp	1034	Single clamp for the front/cab end	1
J	Tie Down Strap	54440400	Tie Down Strap (Short), with Male Buckle-fits 4 bow bed cover systems	1
J	Tie Down Strap	54720400	Tie Down Strap (Long), with Male Buckle-fits 3 bow bed cover systems	1
K	Buckle Assembly	31920120	Single Buckle assembly, w/Female Buckle, Front/cab end	1
L	Tarp	90xxx-20	Vinyl tarp only, ALX vinyl, call Customer Service to order	1
M	Cab Bow	90xxx-10	Disassembly and reassembly of the cover is required, call Customer Service to order	1
N	Tail Bow	90xxx-14	Disassembly and reassembly of the cover is required, call Customer Service to order	1
O	Bow Assembly	90xxx-67	Complete assembly including Latches, Actuator Assembly, cable/conduit, clips with a Rear Bow, call Customer Service to order	1
P	Latch Assembly	28900100	Assembly for driver side	1
Q	Actuator	28900102	Latch actuator assembly	1
R	Latch Assembly	28900101	Assembly for passenger side	1
S	Cable Conduit	31920003	Latch cable cover conduit only. Trimming length may be necessary.	1
T	Conduit Clips	35920202	Latch cable conduit clips	3
U	Striker Bracket Kit	22920102	Rear/tailgate bracket kit standard	1
V	GM Striker Bracket Kit	22000020	Rear/tailgate striker bracket mounting on select GM models, see steps 8A and 8B.	1
W	Maverick Striker Bracket Kit	22900122	Rear/tailgate striker bracket mounting on Ford Maverick, see step 8C.	1
X	GM Rear Stake Pocket	22000090	Rear/tailgate striker bracket stake pocket mounting on select GM models.	1

Bracket Kit - Standard Rear 22920102

Bracket Kit - GM Rear 22000020

Bracket Kit - Maverick Rear 22900122

Bracket Kit - GM rear Stake Pocket 22000090

LIMITED LIFETIME WARRANTY

The cover, including as applicable any hardware kit (e.g., rails, clamps, and bows) and fabric, carries a limited lifetime warranty. This limited warranty is subject to the following terms:

WARRANTY COVERAGE

This tonneau cover is warranted against defects in materials or workmanship. This warranty is void if the product has been damaged in an accident, or due to neglect, unforeseeable use, improper installation, improper servicing, or other cause not arising out of defects in material or workmanship.

WARRANTY IS NOT TRANSFERABLE

The warranty is to the initial owner purchasing the tonneau cover and it is not transferrable to a subsequent end user. Proof of purchase may be required to enforce the warranty rights.

WARRANTY CONDITIONS

Failure to follow these warnings and care instructions will void the warranty:

- Clean with mild automotive soap and water only.
- Do not use conditioners that contain silicone or petroleum (e.g., Armor All®).
- Tonneau cover must be secured at all points when vehicle is in motion. When not fully extended, cover must be completely folded up and secured at the cab with the provided buckle straps and tethers attached. Do NOT drive with the bed cover in a partially open position..
- Check front/cab clamps and retention mechanisms for tightness after a week of driving following installation (or re-installation) of the cover and periodically thereafter.
- Before opening, cover must be free of all foreign materials including snow and ice.
- To avoid potential damage to the cover, panel clamps/latches must be in their stored positions prior to opening/folding the panel.
- Do NOT tow your vehicle from the rear with the cover on your vehicle. If towing from the rear is required, the cover MUST be removed from the vehicle and properly stored.

WARRANTY PERFORMANCE

If all warranty conditions are met, a defective tonneau cover, tarp, or hardware component will either be repaired or replaced (at our option). We reserve the right, for any warranted return, to substitute a newer model of tonneau cover having similar form and function, to offer a warranty discount on an entire replacement system, and/or provide remedies other than those mentioned in this document.

WARRANTY PROCESS

A Return Authorization number must be obtained from our Customer Service Department prior to returning any product. We may require the original item to be returned postage prepaid for final determination. Shipping charges will apply for any repair or replacement. Other than postage or shipping charges, no charge will be made for repair or replacement under this warranty.

This warranty gives you specific legal rights. As an owner, you may also have additional rights and remedies under the laws of your state.

SOMETHING DAMAGED? MISSING PARTS?

CALL US FIRST
800-877-2588

WE CAN HELP YOU QUICKLY AND EASILY OVER THE PHONE

Experienced Customer Service staff are available
to answer all your truck bed cover questions

CUSTOMER SERVICE HOURS

8:30 a.m. TO 6:00 p.m. EST, MONDAY - FRIDAY

Truck bed cover model: _____

Purchase date: _____

Lot code: _____

Lot code can be found on the underside of cover.