

! IMPORTANT

READ BEFORE YOU BEGIN INSTALLATION

IT IS CRITICAL FOR YOUR SAFETY THAT YOU CAREFULLY READ AND FOLLOW THE SAFETY CAUTIONS AND INSTALLATION INSTRUCTIONS BOTH PRIOR TO AND DURING INSTALLATION.

USER SAFETY CAUTION

During installation, be mindful of the potential for sharp edges on the product or vehicle. Taking proper safety precautions helps ensure a safe and smooth installation process.



Always wear protective gloves and handle components with care to reduce the risk of injury.

TEMPERATURE SURFACE CAUTION

During high temperatures or extended sun exposure, surfaces of this product may become hot to the touch, posing a risk of burns or injury. Use caution when handling the product in hot weather and allow time for it to cool before contact.



Always check surface temperature before use to ensure safe handling conditions.

FASTENER TORQUE CAUTION

All fasteners must be tightened to the specified torque values provided in the installation instructions to ensure proper fit and safe operation of the tonneau cover. Under- or over-tightening can lead to product failure, potential damage to your vehicle, injury, or safety hazards while driving.

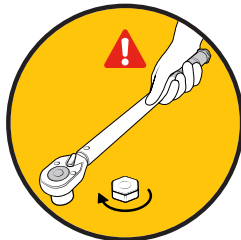

Always use a calibrated torque wrench and follow the specifications in the installation instructions.

PINCH POINT SAFETY CAUTION

This tonneau cover may create pinch points when closing or operating near solid surfaces such as the truck bed rails or tailgate. To prevent injury, keep hands, fingers, and other body parts clear of moving parts during operation.



Always operate the cover slowly and with caution to ensure safe and proper use.

! IMPORTANT

READ BEFORE YOU BEGIN INSTALLATION

IT IS CRITICAL FOR YOUR SAFETY THAT YOU CAREFULLY READ AND FOLLOW THE SAFETY CAUTIONS AND INSTALLATION INSTRUCTIONS BOTH PRIOR TO AND DURING INSTALLATION.

ENTRAPMENT SAFETY WARNING

This tonneau cover does not feature a manual release mechanism from inside the truck bed. To prevent the risk of entrapment, never allow anyone to be inside the bed of the truck when the cover is closed.

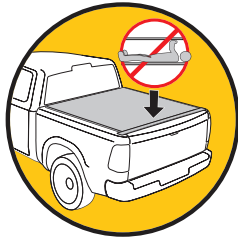

Always ensure the area is clear before closing the cover, and keep the cover securely latched when not in use to avoid accidental closure.

COVER ATTACHMENT WARNING

A partially folded up or unsecured cover may detach during transit, risking vehicle or property damage and personal injury.



Always verify the tonneau cover is properly secured before operating the vehicle.

CARGO TRANSPORT WARNING

When transporting cargo that is taller than the truck bed, the cover must be fully folded open and securely fastened with both retainer straps. An unsecured cover can detach while driving, risking vehicle or property damage and personal injury.

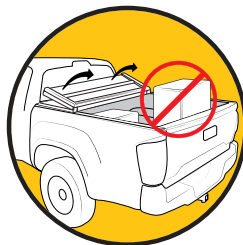

Never operate the vehicle with a partially folded up cover.

COVER POSITION WARNING

Before operating the vehicle, always verify the tonneau cover is either fully folded open and secured with both buckles or fully folded closed and securely latched down.

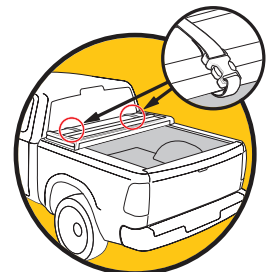

Never operate the vehicle if the tonneau cover is not properly secured.

Any damaged or missing parts?

Parts will be shipped to you directly.

Call 800-877-2588, Mon - Fri, 8:30 a.m. - 6:00 p.m. EST

NOTE: It is important that all areas where the bed cover mounts are clean and free of debris prior to installing.

TOOLS REQUIRED

- Torx wrench - T-50
- Hex wrench - 1/8"
- Torx wrench - T-30
- Knife or cutting tool

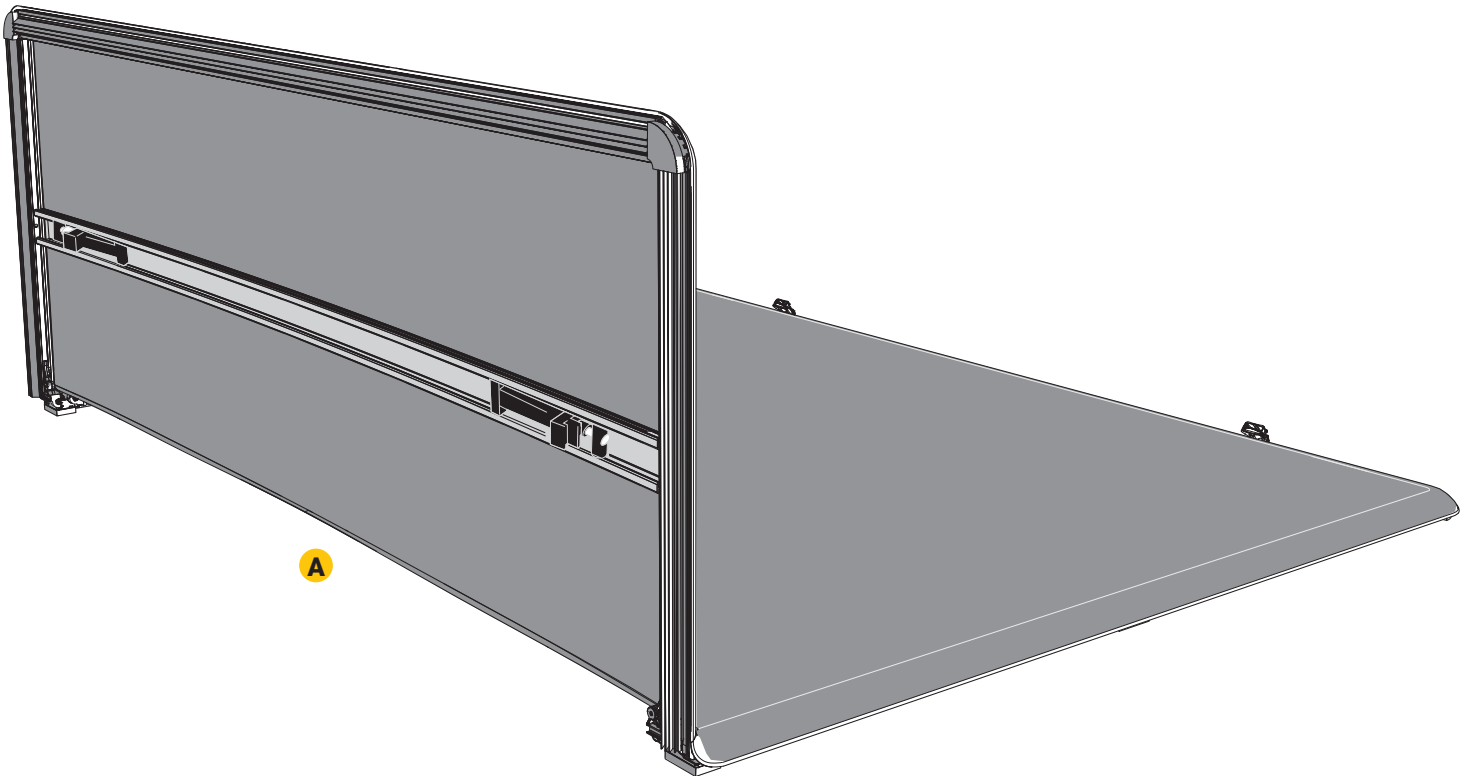

PARTS INCLUDED IN YOUR KIT

- A** Cover assembly
- B** 1x Cab bracket, driver side
- C** 1x Cab bracket, passenger side
- D** 2x M8 bolts T-50
- E** 2x Hex button head screws with washers
- F** 4x Washers
- G** 2x Well nuts
- H** 2x Bulkhead brackets*
- I** 4x T-30 Torx screws with washers
- J** 2x Tailgate brackets

*Kit 22000097 - for use with NO weld nut at bulkhead only

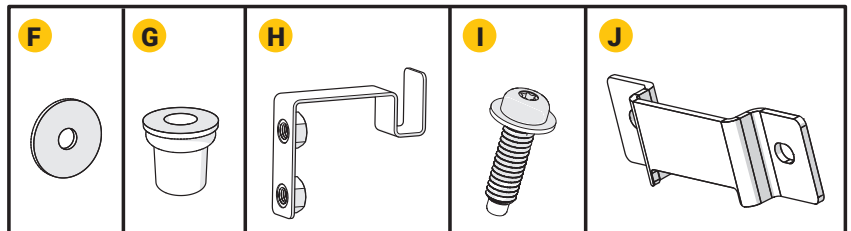
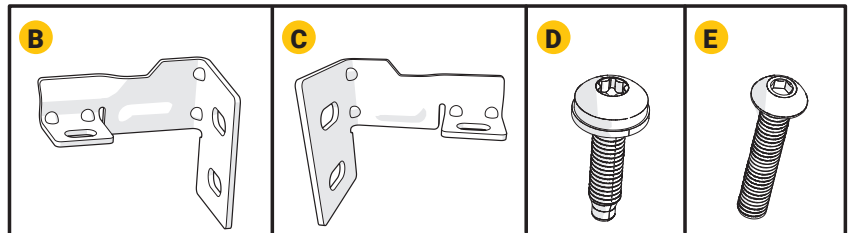

1 Identify the bulkhead hole configuration of your vehicle located near the cab.

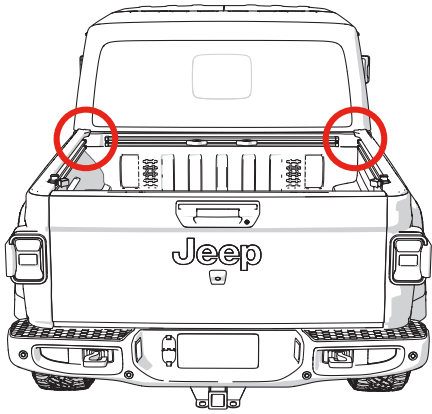

Vehicles **WITH** a weld nut

Weld nut VIN BX210534 and OLDER vehicles

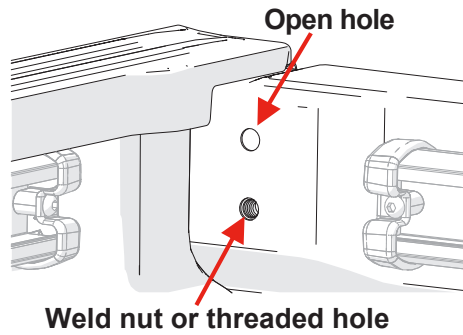

Vehicles **WITHOUT** a weld nut

NO weld nut VIN BX210535 and NEWER vehicles
Use kit 22000097 -* (H & I)

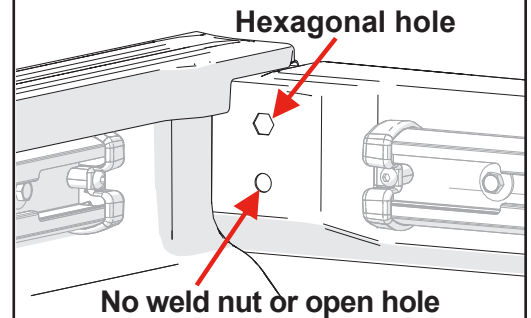

2 If you have a vehicle **WITH** a weld nut, VIN BX210534, and OLDER vehicles. Install the cab brackets (B & C) by inserting the hex button head screw with washer (E) through the upper hole of the cab brackets (B & C). Then install the M8 bolt T-50 (D) through the bottom hole in the cab brackets (B & C). On the backside of the bracket (B & C) thread a washer (F) and a well nut (G) onto the bolt (D).

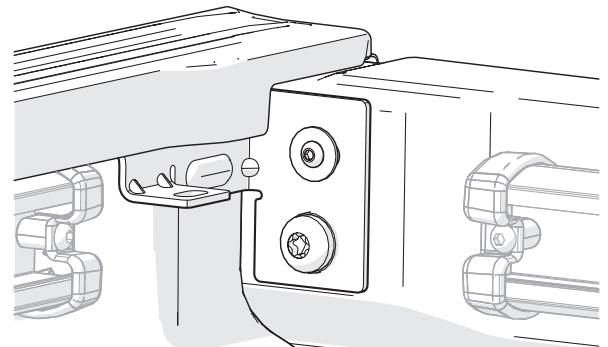
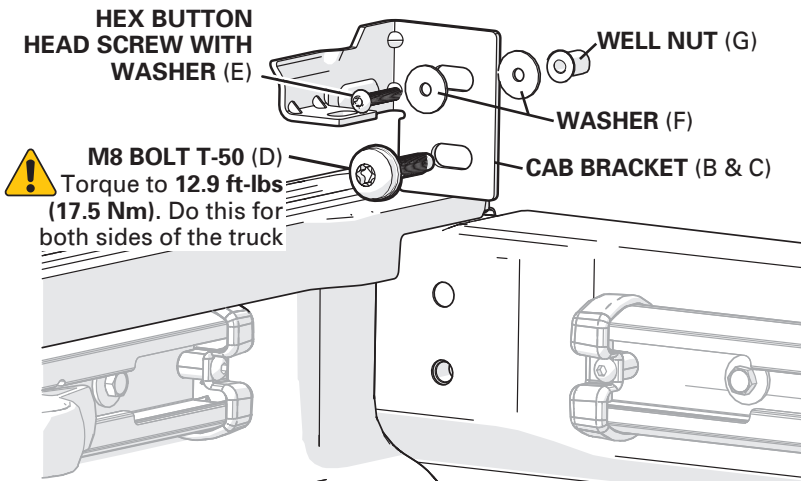

3 If you have a vehicle **WITHOUT** a weld nut, VIN BX210535, and NEWER vehicles. Place the bulkhead brackets (H) underneath the truck's bed flange and align with the 2 holes in the bulkhead. Install the cab brackets (B & C) by inserting the M8 bolt T-45 (I) through the upper hole of the cab brackets (B & C). Then install the M8 bolt T-50 (D) through the bottom hole in the cab brackets (B & C). Make sure that both fasteners go into the bulkhead brackets (H).

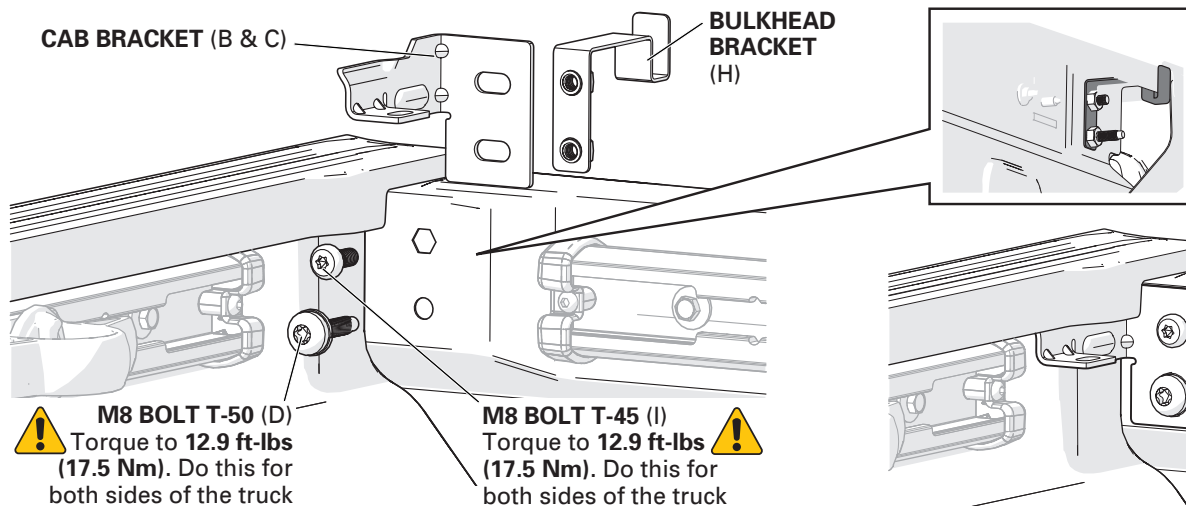

This view shows how the bulkhead bracket is installed underneath the bulkhead.

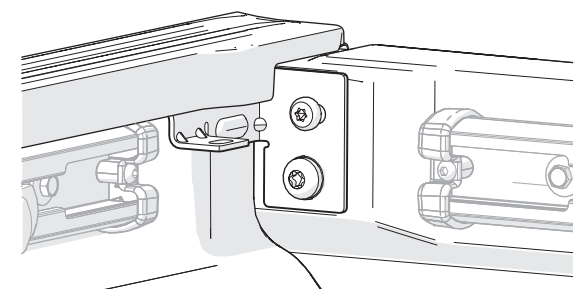

4 Before placing the cover (A) on the truck bed, remove both front clamp knobs. Leave the cab clamp rods in place.

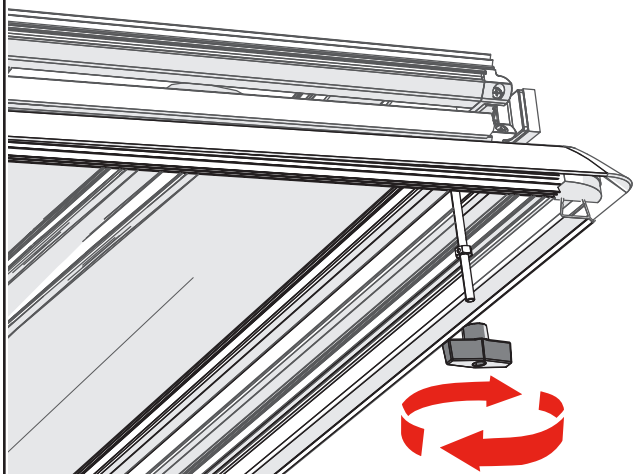

5 Place the folded cover (A) onto the truck bulkhead and bed rails, making sure to slide the cab clamp rods through the cab clamp brackets. Align both driver and passenger sides.

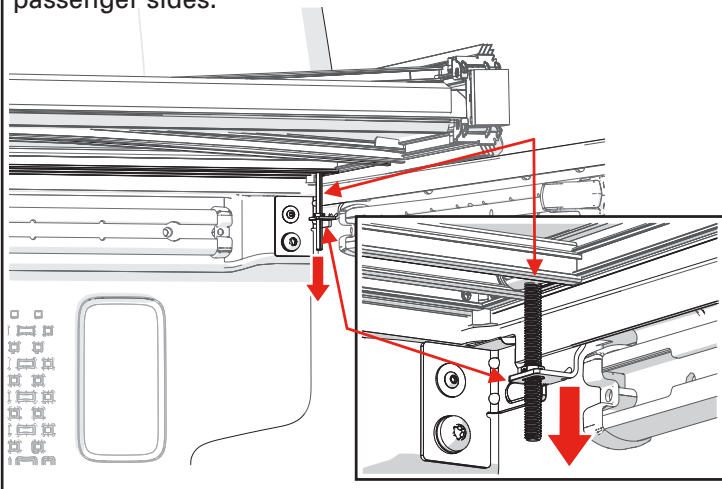

6 Thread the cab clamp knobs back onto the rods. Securely tighten on both sides. **Do NOT use a wrench or overtighten.** ⚠️

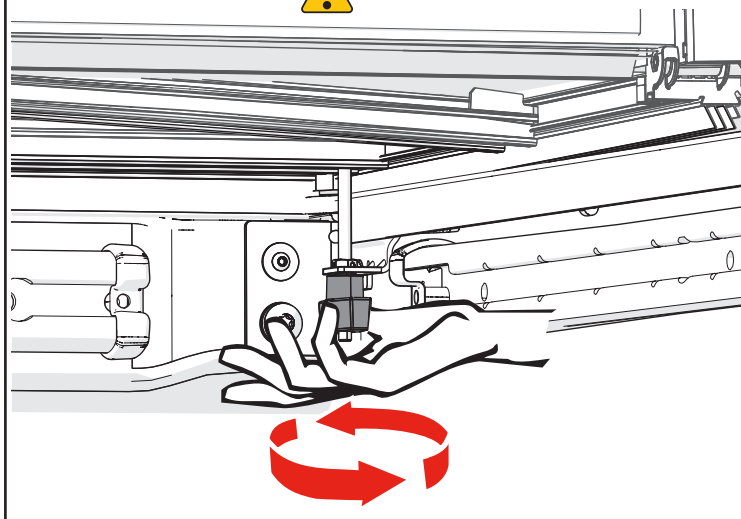

7 If the bed rail caps are not trimmed in the rear (tailgate) section, cut using the scribed lines to expose the area shown. ⚠️

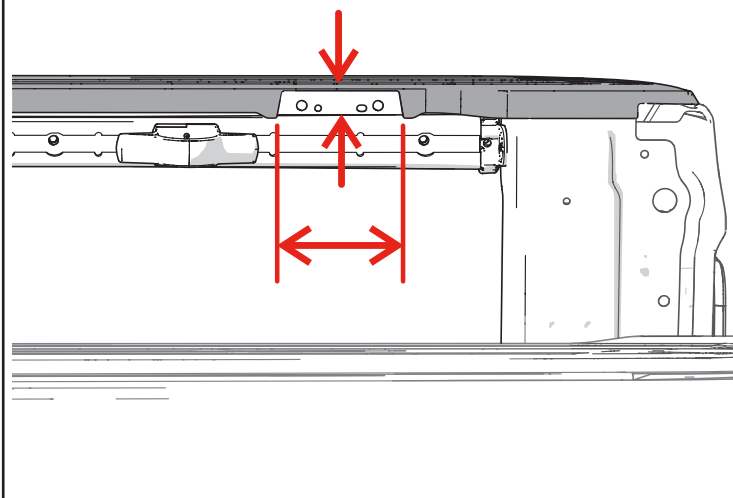

8 Attach the tailgate brackets (J) to the bed rail through the bed rail holes using the T-30 Torx screws with washers (I). **Tighten to 8 N-m (71 in-lb).** Do this on both driver and passenger sides. ⚠️

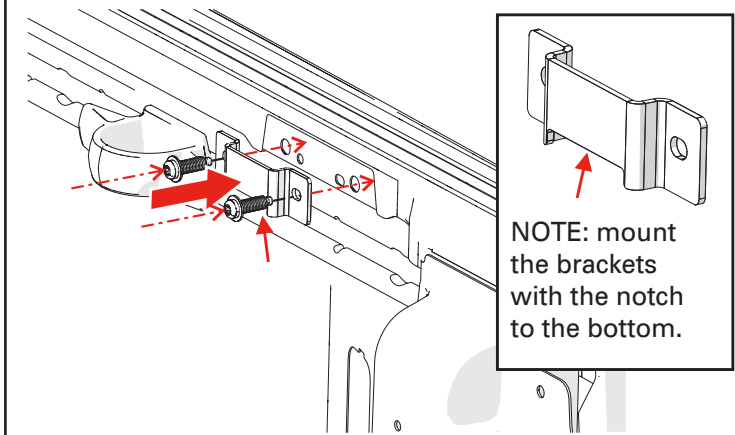

9 Close the tailgate and close the cover (A). Check that the cover is parallel and square with the truck bed and bed rails. If not parallel, adjust the cover from side to side.

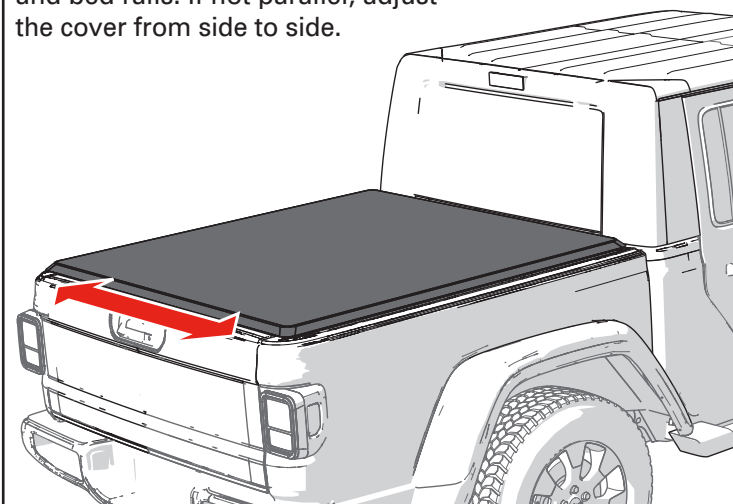

10 Open the tailgate, swing the tail clamps down from the stowed position and slide them toward the truck bed rail. Swing the clamps and pull down so the clamp jaw is tucked under the rear truck bed rail bracket. **NOTE: the clamp jaw fits into the bracket notch.**

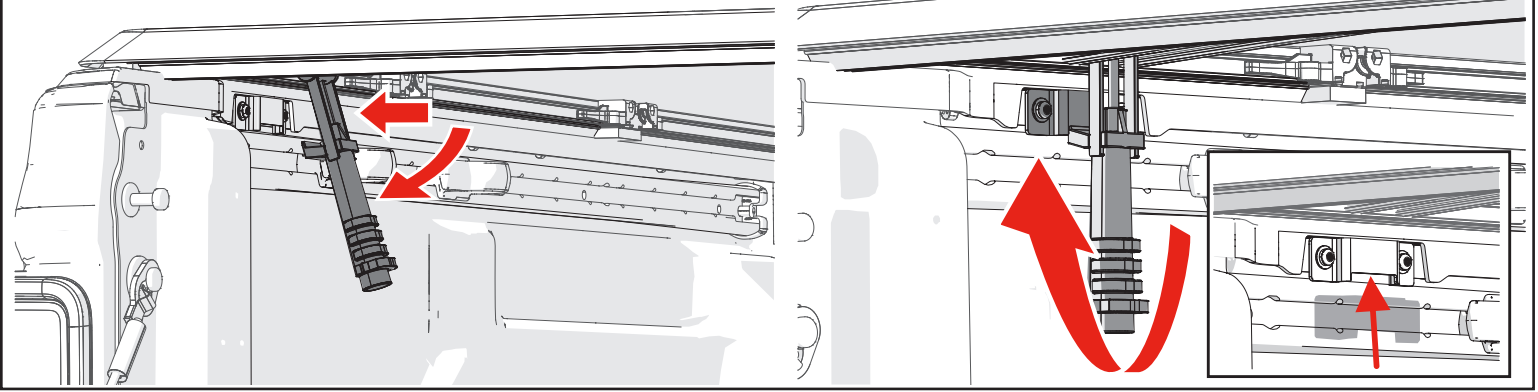

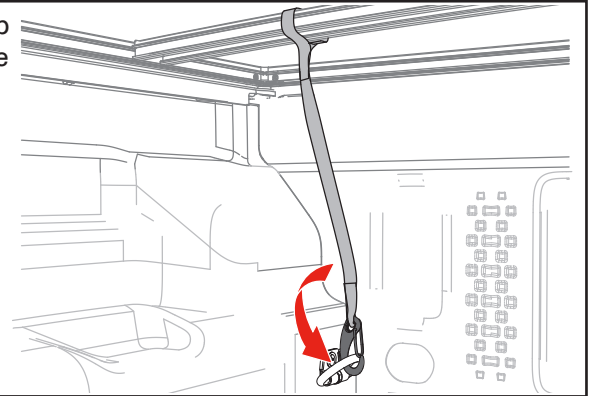

11 The tethers come installed looped over the bed cover bow with a clamp at the other end. Hook the tether onto the truck bed tie-down. Install the tethers on both sides of the cover. 



DRIVING WITH THE TONNEAU OPEN

Release the rear clamps and fold the cover forward.

 **IMPORTANT:** Before folding the second section of the cover, the rear clamps must be stowed into the rail to prevent damage to the fabric. **Failure to stow the handles will puncture the tarp and void the warranty.**

 Fold the cover forward and fasten **BOTH** straps to the front rail. Check that the straps are tight. **Failure to do so could allow the wind to blow the cover back resulting in damage to the cover and truck.**

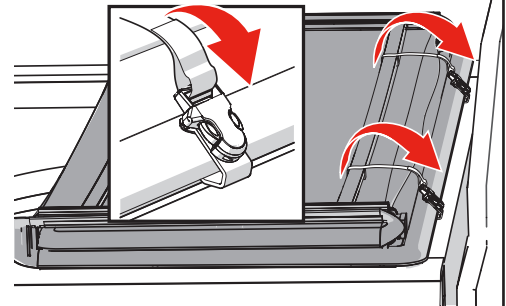
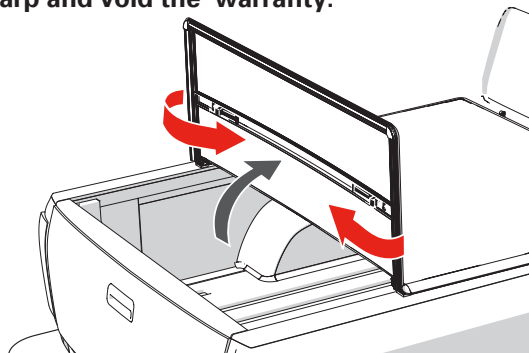
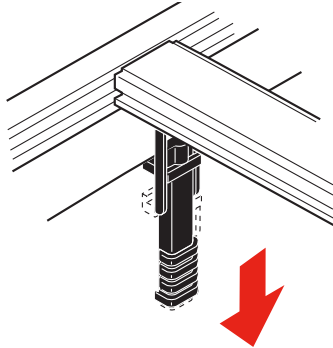

IMPORTANT

Re-tighten the front/cab clamps and tethers after the first week of driving the vehicle. Also periodically check the clamps and tethers to ensure they are secure.

Closed/Extended Position – Bed cover must be completely secured by all four (4) clamps.

Open/Folded Position – Bed cover must be completely folded up (all panels) and secured at the cab with the provided buckles straps and with both tethers attached.

Do NOT drive with the bed cover in a partially open position.



Do NOT allow the vehicle to be towed backwards without first removing the cover from the vehicle.



Remove any snow or foreign matter before folding the bed cover.

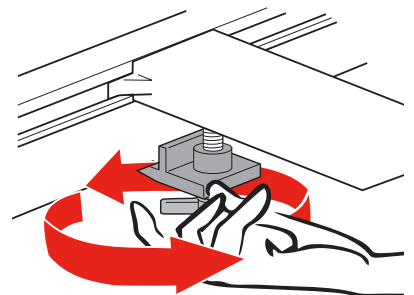

REPLACEMENT PARTS

Replacement parts can be ordered online at extang.com/replacement-parts or you can contact our Customer Service Department for assistance. When ordering, xxx represents the 3 digit suffix, as referenced on the sales receipt or vehicle application list.

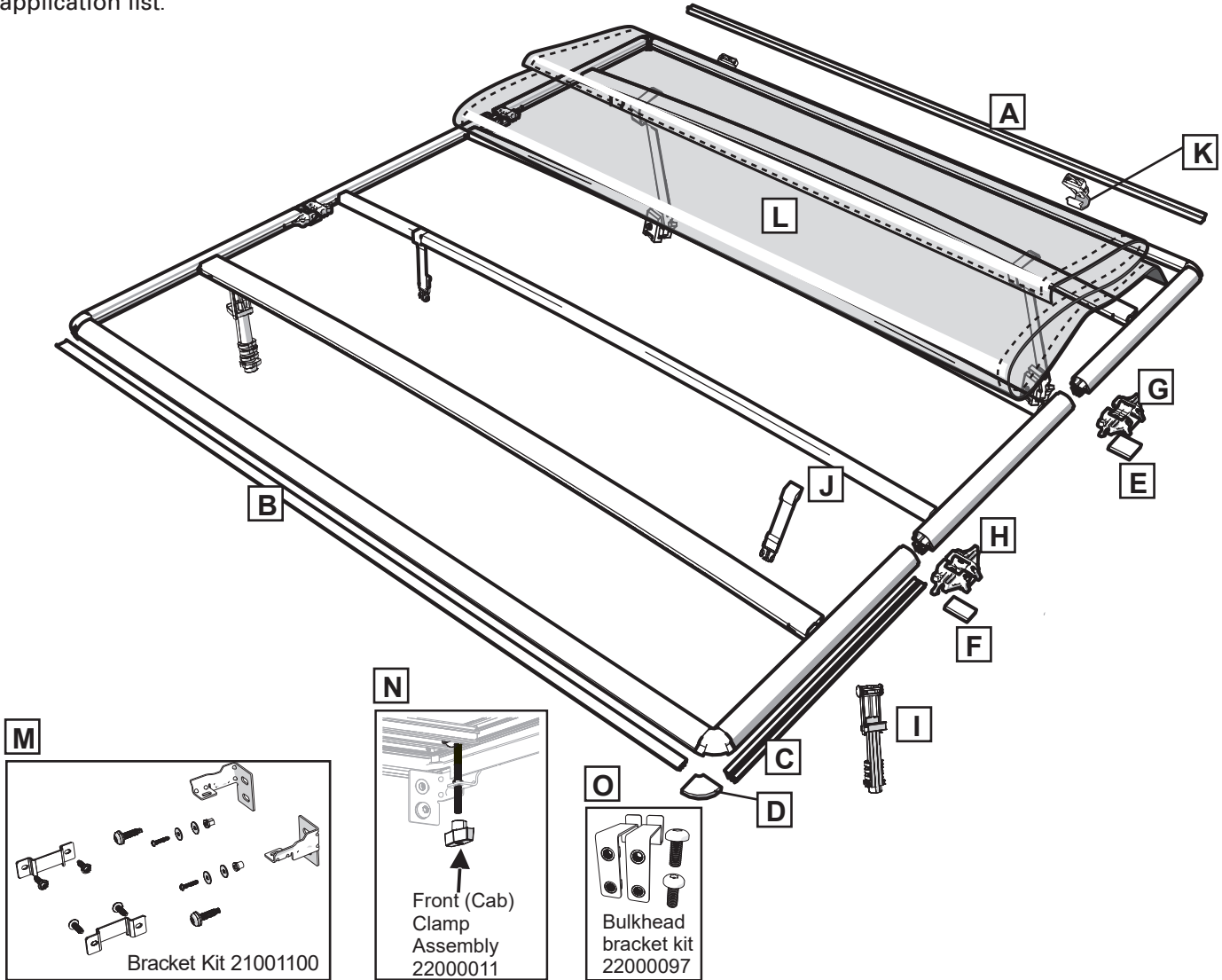

Call Out	Title	Part Number	Description	Application	Qty
A	Cab Seal	32002112	Single length seal (6'), hollow seal, cut to fit	Most vehicles	1
A	Cab Seal	32270600	Single length seal (6'), Flap seal, cut to fit	Honda, Nissan Frontier, Suzuki Equator	1
A	Cab Seal	32001668	Single length seal (6'), ribbed D-seal large, cut to fit	Toyota and Mitsubishi	1
A	Cab Seal	32000900	Single length seal (6'), ribbed D-seal short, cut to fit	RamBox 2009-2018 DS body style (4th generation only)	1
B	Tail Seal	32562569	Single length seal, (69"), 2-fin seal, cut to fit		1
B	Tail Seal	32563200	Single length seal, (68"), 4-fin, cut to fit	Most vehicles	1
B	Tail Seal	32002119	Single length seal, (68"), 4-fin, cut to fit	2021+ F150, Super Duty	1
C	Side Seal	32000685	Single length (68") Riser Side Seal, one length will fit two panel sides, cut to fit (there are 6 sides per cover). Two seals for 6' beds, three for longer beds.	Most vehicles	1
C	Side Seal	32560368	Single length (68") 3-Fin Side Seal, one length will fit 2 panel sides, cut to fit, (there are 6 sides per cover). Two seals for 6' beds, three for longer beds.	Most vehicles	1
D	Corner Seal	92xxx-19	Measure for thickness- 0.375", 0.5", 0.75"	Call Customer Service with xxx suffix referenced per vehicle	1
D	Corner Seal	93xxx-19	Measure for thickness- 0.375", 0.5", 0.75"	Call Customer Service with xxx suffix referenced per vehicle	1
D	Corner Seal	94xxx-19	Measure for thickness- 0.375", 0.5", 0.75"	Call Customer Service with xxx suffix referenced per vehicle	1
E	Cab Hinge Seal	32920104	Seal only, 0.25" Large Hinge Pad	Measure thickness or call Customer Service with xxx suffix reference	1
E	Cab Hinge Seal	32440401	Seal only, 0.375" Large Hinge Pad	Measure thickness or call Customer Service with xxx suffix reference	1
F	Tailgate Hinge Seal	32920102	Seal only, 0.25" Small Hinge Pad	Measure thickness or call Customer Service with xxx suffix reference	1
F	Tailgate Hinge Seal	32440402	Seal only, 0.375" Small Hinge Pad	Measure thickness or call Customer Service with xxx suffix reference	1
G	Cab Hinge Assembly	31442015	Seal not included, see item Cab Hinge Seal (E)	Most vehicles	1
H	Tailgate Hinge Assembly	31442005	Seal not included, see item Tailgate Hinge Seal (F)	Most vehicles	1
I	Tail Clamp	31003005	Single EZ Lock Clamp for the tailgate side	Most Vehicles	1
J	Tie Down Strap	54440400	(Short) Tie Down Strap, w/Male Buckle-fits 4 bow bed cover systems	Most Vehicles	1
J	Tie Down Strap	54720400	(Long) Tie Down Strap, w/Female Buckle-fits 3 bow bed cover systems	Most vehicles	1
K	Buckle Assembly	31920120	Single Buckle assembly, w/Female Buckle	Most vehicles	1
L	Tarp	92xxx-20	Vinyl tarp only, Trifecta 2.0 vinyl	Call Customer Service with xxx suffix referenced per vehicle	1
L	Tarp	94xxx-20	Vinyl tarp only, Trifecta Signature Series vinyl	Call Customer Service with xxx suffix referenced per vehicle	1
M	Bracket Kit	21001100	Clamp bracket kit for front/cab and rear/tailgate	Gladiator	1
N	Front Clamp	22000011	Front/cab clamp assembly	Gladiator	1
O	Bracket Kit	22000097	Bulkhead bracket kit	Gladiator	1

LIMITED LIFETIME WARRANTY

The cover, including as applicable any hardware kit (e.g., rails, clamps, and bows) and fabric, carries a limited lifetime warranty. This limited warranty is subject to the following terms:

WARRANTY COVERAGE

This tonneau cover is warranted against defects in materials or workmanship. This warranty is void if the product has been damaged in an accident, or due to neglect, unforeseeable use, improper installation, improper servicing, or other cause not arising out of defects in material or workmanship.

WARRANTY IS NOT TRANSFERABLE

The warranty is to the initial consumer purchasing the tonneau cover and it is not transferable to a subsequent end user. Proof of purchase may be required to enforce the warranty rights.

WARRANTY CONDITIONS

Failure to follow these warnings and care instructions will void the warranty:

- Clean with mild automotive soap and water only.
- Do not use conditioners that contain silicone or petroleum.
- Tonneau cover must be secured at all points when vehicle is in motion. When not fully extended, cover must be completely folded up and secured at the cab with the provided buckle straps and tethers attached. Do NOT drive with the bed cover in a partially open position..
- Check front/cab clamps and retention mechanisms for tightness after a week of driving following installation (or re-installation) of the cover and periodically thereafter.
- Before opening, cover must be free of all foreign materials including snow and ice.
- To avoid potential damage to the cover, panel clamps/latches must be in their stored positions prior to opening/folding the panel.
- Do NOT tow your vehicle from the rear with the cover on your vehicle. If towing from the rear is required, the cover MUST be removed from the vehicle and properly stored.

WARRANTY PERFORMANCE

If all warranty conditions are met, a defective tonneau cover, tarp, or hardware component will either be repaired or replaced (at our option). We reserve the right, for any warranted return, to substitute a newer model of tonneau cover having similar form and function, to offer a warranty discount on an entire replacement system, and/or provide remedies other than those mentioned in this document.

WARRANTY PROCESS

A Return Authorization number must be obtained from our Customer Service Department prior to returning any product. We may require the original item to be returned postage prepaid for final determination. Shipping charges will apply for any repair or replacement. Other than postage or shipping charges, no charge will be made for repair or replacement under this warranty.

This warranty gives you specific legal rights. As a consumer, you may also have additional rights and remedies under the laws of your state.

WARRANTY REGISTRATION

Warranty registration must be on file and/or proof of original purchase (detailed and dated receipt) required for warranty to be effective.

Register online at <https://realtruck.com/extang-warranty>

**REGISTER
YOUR
WARRANTY
ONLINE**



SOMETHING DAMAGED? MISSING PARTS?

CALL US FIRST
800-877-2588

WE CAN HELP YOU QUICKLY AND EASILY OVER THE PHONE

Experienced Customer Service staff are available
to answer all your truck bed cover questions

CUSTOMER SERVICE HOURS

8:30 a.m. TO 6:00 p.m. EST, MONDAY - FRIDAY

Truck bed cover model: _____

Purchase date: _____

Lot code: _____

Lot code can be found on the underside of cover.