

⚠️ IMPORTANT

READ BEFORE YOU BEGIN INSTALLATION

IT IS CRITICAL FOR YOUR SAFETY THAT YOU CAREFULLY READ AND FOLLOW THE SAFETY CAUTIONS AND INSTALLATION INSTRUCTIONS BOTH PRIOR TO AND DURING INSTALLATION.

USER SAFETY CAUTION

During installation, be mindful of the potential for sharp edges on the product or vehicle. Taking proper safety precautions helps ensure a safe and smooth installation process.



Always wear protective gloves and handle components with care to reduce the risk of injury.

TEMPERATURE SURFACE CAUTION

During high temperatures or extended sun exposure, surfaces of this product may become hot to the touch, posing a risk of burns or injury. Use caution when handling the product in hot weather and allow time for it to cool before contact.



Always check surface temperature before use to ensure safe handling conditions.

FASTENER TORQUE CAUTION

All fasteners must be tightened to the specified torque values provided in the installation instructions to ensure proper fit and safe operation of the tonneau cover. Under- or over-tightening can lead to product failure, potential damage to your vehicle, injury, or safety hazards while driving.

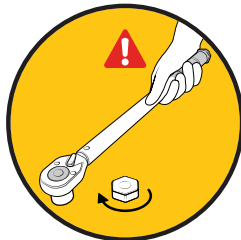

Always use a calibrated torque wrench and follow the specifications in the installation instructions.

PINCH POINT SAFETY CAUTION

This tonneau cover may create pinch points when closing or operating near solid surfaces such as the truck bed rails or tailgate. To prevent injury, keep hands, fingers, and other body parts clear of moving parts during operation.



Always operate the cover slowly and with caution to ensure safe and proper use.

IMPORTANT

READ BEFORE YOU BEGIN INSTALLATION

IT IS CRITICAL FOR YOUR SAFETY THAT YOU CAREFULLY READ AND FOLLOW THE SAFETY CAUTIONS AND INSTALLATION INSTRUCTIONS BOTH PRIOR TO AND DURING INSTALLATION.

ENTRAPMENT SAFETY WARNING

This tonneau cover does not feature a manual release mechanism from inside the truck bed. To prevent the risk of entrapment, never allow anyone to be inside the bed of the truck when the cover is closed.

Always ensure the area is clear before closing the cover, and keep the cover securely latched when not in use to avoid accidental closure.

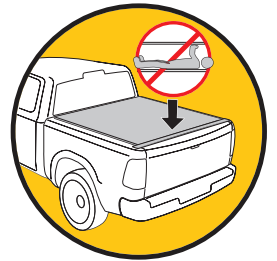

CARGO TRANSPORT WARNING

Do not attempt to close the tonneau cover over cargo that is taller than the depth of the truck bed.

Never force the cover to close improperly.

Forcing the cover can:

- Prevent the cover from lying flat and latching securely.
- Damage the cover's hinge and cause the cover to kink.
- Damage the rear tail panel and cause it to become detached.

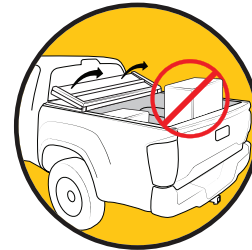

READ THIS FIRST



ENDURE ALX INSTALLATION SUPPLEMENT Nissan, Toyota, Honda, Ram, Jeep, GM CarbonPro bed & Ford

This supplement replaces **steps 3-7** in the main install sheet for the vehicles listed below. Read this guide before proceeding with the main installation.

Nissan Titan 2016+ W/O Utili-Track System, Isuzu D-Max 2020, Nissan Navara 2015-2020

and Toyota Hilux 2005-2015 WITHOUT the Utili-Track System.....1

Nissan Titan 2016+ WITH the Utili-Track System.....2

Toyota Tacoma 2016+.....3

Toyota Tundra 2016+.....4

Honda Ridgeline 2017+.....5-6

RamBox DT 2019+.....7-8

Jeep Gladiator.....9-12

GM CarbonPro Bed.....13-14

Ford Ranger 2024-2025.....15-17

Ford Ranger 2026+.....18-20



This supplement replaces **steps 3-7** in the main install sheet for the vehicles noted. Read this guide before proceeding with the installation.

Nissan Titan 2016+ W/O Utili-Track System, Isuzu D-Max 2020, Nissan Navara 2015-2020 and Toyota Hilux 2005-2015 WITHOUT the Utili-Track System

1 It is important that all areas where the bed cover mounts are clean and free of debris prior to installing.

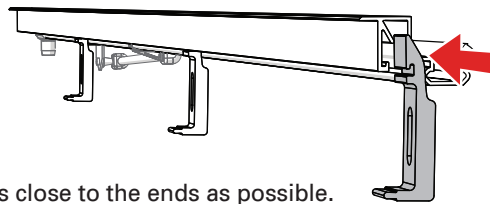

Slide the outer clamp halves into the tapered slot of the bed rails.

Position the front and rear clamps as close to the ends as possible. They should be less than 12" from the end of the rail.

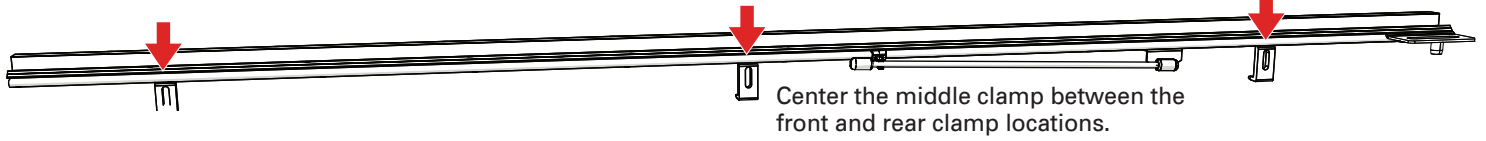

Center the middle clamp between the front and rear clamp locations.

2 Place the bed rail onto the truck cap. Assemble the inner clamp halves to the outer clamps positioned on the rail. Adjust the clamp positions as necessary. Thread the bolt through a washer and into the clamp half.

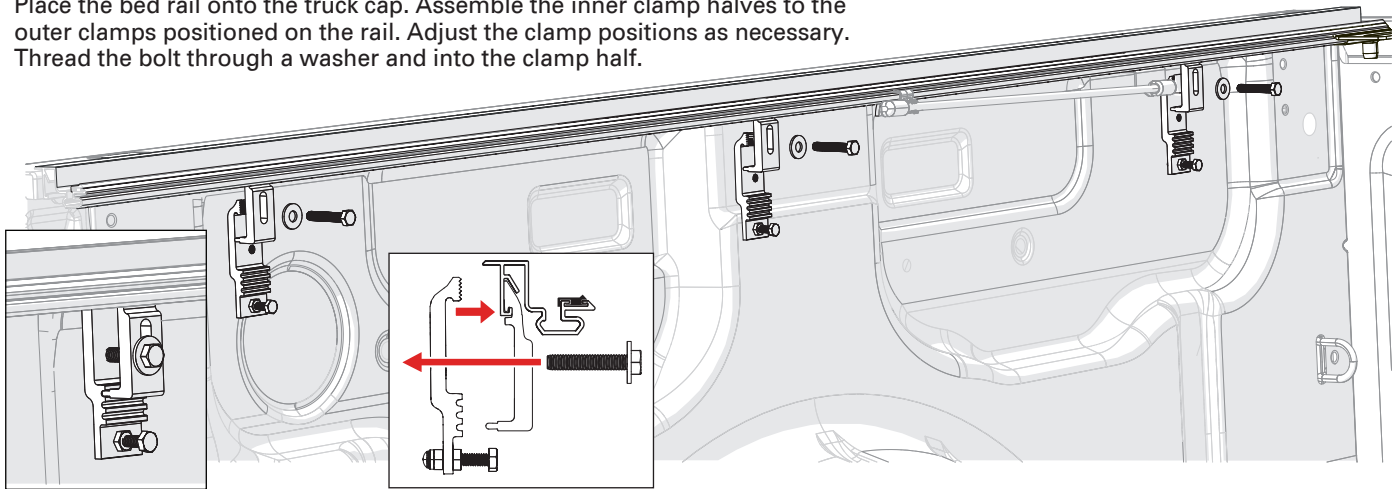

3 Tighten the clamp bolts, the front, middle and rear.

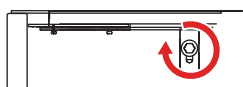

Torque the clamp bolts to 13.6 Nm (120 in-lb)

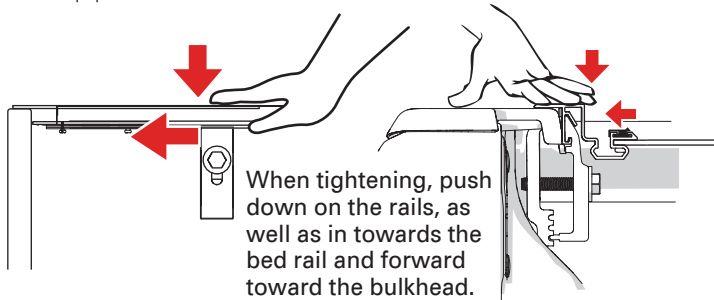

When tightening, push down on the rails, as well as in towards the bed rail and forward toward the bulkhead.

4 The lower adjustment bolt and rubber stops are used to support and level the rail.

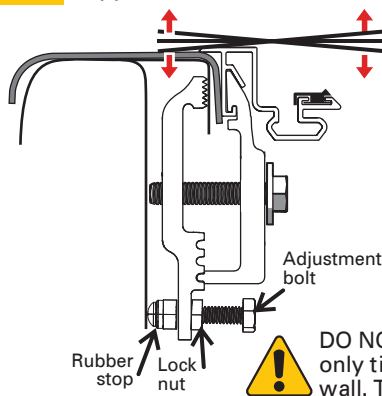

Loosen the lock nut and adjust the bolt in or out. Re-tighten the lock nut.

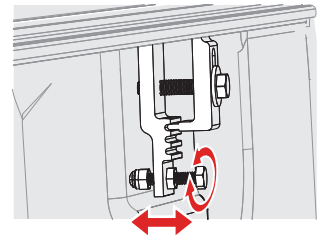

DO NOT torque the adjustment bolt, only tighten to position it to the bed wall. The lock nut needs only to be snug.

5 Repeat all of the steps for both sides. Return to the standard installation instructions. Follow step 2 for the bulkhead seal, then skip to step 8.

This supplement replaces **steps 3-7** in the main install sheet for the vehicles noted. Read this guide before proceeding with the installation.

Nissan Titan 2016+ WITH the Utili-Track System

1 It is important that all areas where the bed cover mounts are clean and free of debris prior to installing.

Position the front and rear clamps as close to the ends as possible. They should be less that 12" from the end of the rail.

Slide the outer clamp halves into the tapered slot of the bed rails.

Center the middle clamp between the front and rear clamp locations.

2 Slide the back half of the clamp directly into the vehicle tracks. The clamp halves install with the grooves facing out. Align the clamp as shown with the large grooved end first. **NOTE:** If reusing the factory tie-downs be sure to install them intermittently with the bed cover clamp halves.

3 Place the rail onto the truck bed rail, match the two clamp halves, thread a bolt through a washer into the inner clamp half. **NOTE:** Some drop-in liners may require trimming in the corners to fit the rail.

4 Tighten the clamp bolts, the front, middle and rear.

When tightening push down on the rails, as well as in towards the bed rail and forward toward the bulkhead.

Torque the clamp bolts to 13.6 Nm (120 in-lb)

5 Repeat all of the steps for both sides. Return to the standard installation instructions. Follow step 2 for the bulkhead seal, then skip to step 8.

INSTALLATION SUPPLEMENT

This supplement replaces **steps 3-7** in the main install sheet for the vehicles noted. Read this guide before proceeding with the installation.

Toyota Tacoma 2016+

- 1** It is important that all areas where the bed cover mounts are clean and free of debris prior to installing.

Remove the factory cab header rail. Remove the backing from the foam seals, and adhere a seal to both sides of the header rail. Reassemble the header rail to the truck, tighten the fasteners to 7.5Nm, (66.5 in-lb)

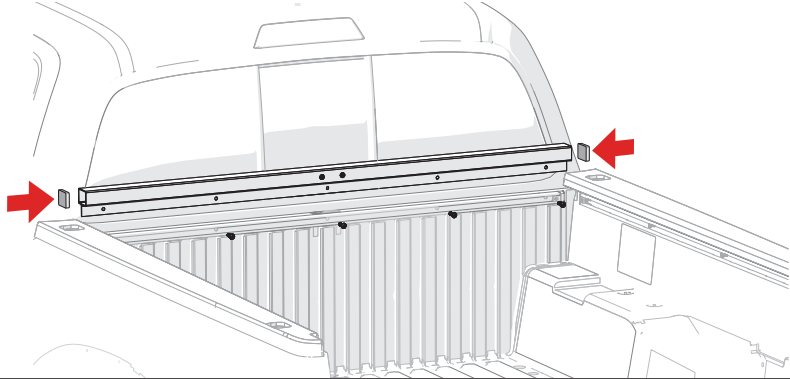

- 2** Remove the factory cargo rail and fasteners. Retain both for later reinstallation.

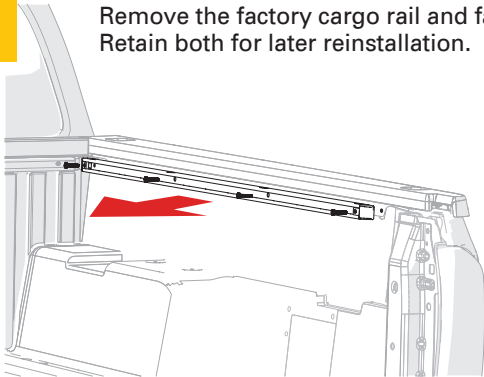

- 3** Align and slide the cover rail brackets into the slot in the rail. The brackets will be spaced to match the factory cargo rail holes.

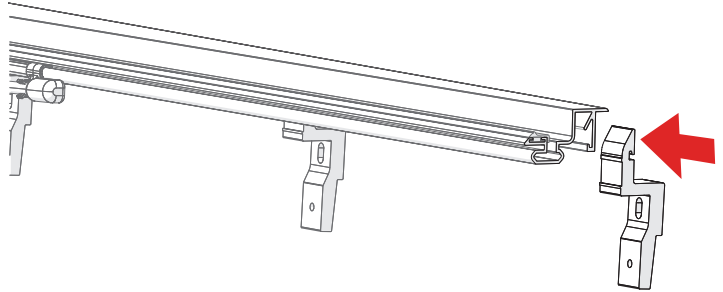

- 4** Mount the cover rail and brackets to the truck bed using the factory cargo rail fasteners and into the cargo rail mounting holes.

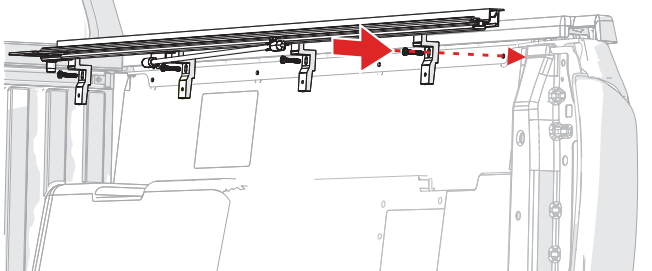

- 5** Make sure the cover rail is pushed forward, tight against the bulkhead. Tighten the fasteners.



Torque the fasteners to 7.5 Nm (66.5 in-lb)

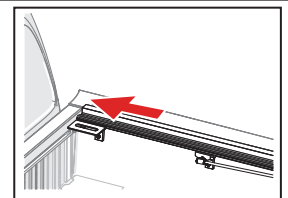

- 6** Mount the factory cargo rail to the lower holes of the cover brackets using the provided small fasteners.



Torque the fasteners to 7.5 Nm (66.5 in-lb)

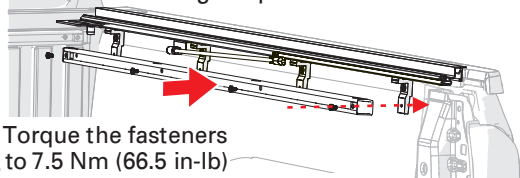

- 7** Repeat all of the steps for both sides. Return to the standard installation instructions. Follow step 2 for the bulkhead seal, then skip to step 8.

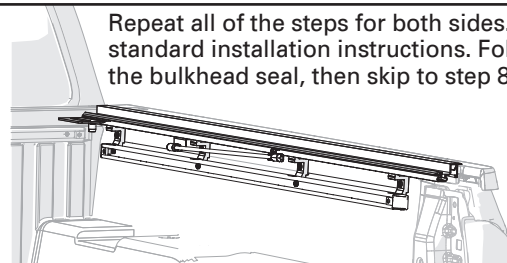

This supplement replaces **steps 3-7** in the main install sheet for the vehicles noted. Read this guide before proceeding with the installation.

Toyota Tundra 2016+

- 1** It is important that all areas where the bed cover mounts are clean and free of debris prior to installing.

Remove the factory cargo rails and fasteners. Retain both for later reinstallation.

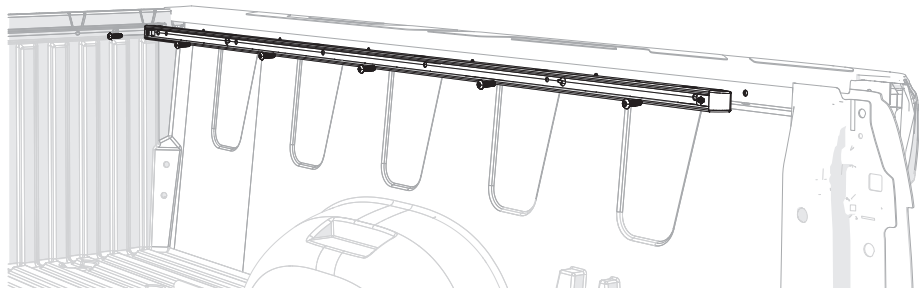

- 2** Align and slide the cover rail brackets into the slot in the rail. The brackets will be spaced to match the factory cargo rail holes.

Mount the cover rail and brackets to the truck bed using the factory cargo rail fasteners and into the cargo rail mounting holes.



- 3** Make sure the cover rail is pushed forward, tight against the bulkhead. Tighten the fasteners.

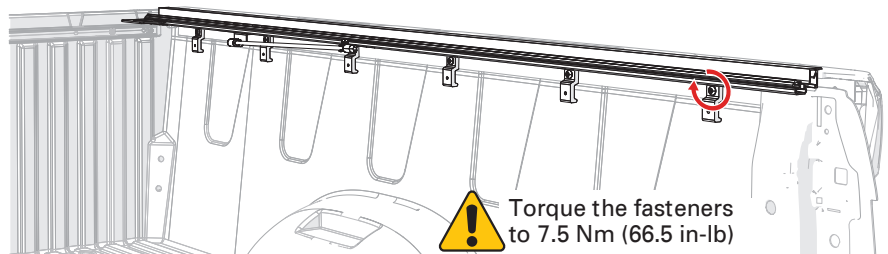
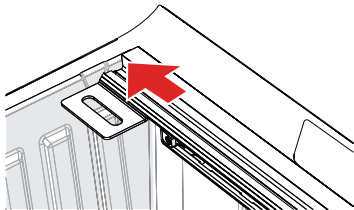

Torque the fasteners to 7.5 Nm (66.5 in-lb)

- 4** Mount the factory cargo rail to the lower holes of the cover brackets using the provided small fasteners.

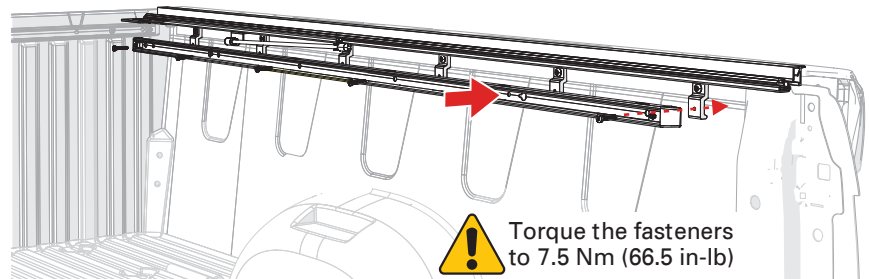

Torque the fasteners to 7.5 Nm (66.5 in-lb)

- 5** Repeat all of the steps for both sides. Return to the standard installation instructions. Follow step 2 for the bulkhead seal, then skip to step 8.

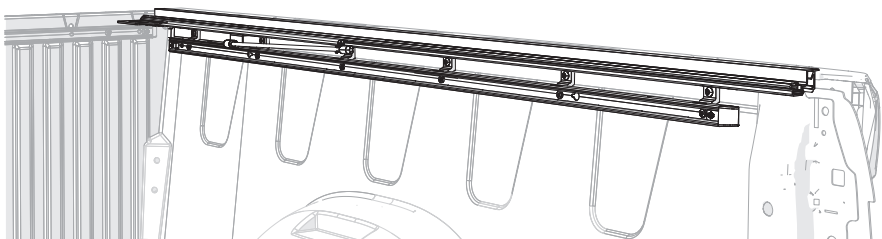

This supplement replaces **steps 3-7** in the main install sheet for the vehicles noted. Read this guide before proceeding with the installation.

Honda Ridgeline 2017+ Page 1 of 2

1 It is important that all areas where the bed cover mounts are clean and free of debris prior to installing.

Assemble the cab and rear mounting brackets to the accessory mount brackets slide them into the rail channels.

2 Remove the upper factory cleats and fasteners. Keep the fasteners for reuse, the cleats will not be reinstalled.

Slide the mounting brackets to the front and to the rear. Set the cover rail onto the truck bed rail and align the bracket holes with the factory cleat mounting holes.

3 Thread the factory fasteners through the cover rail mounting brackets and into the factory holes where the cleats were mounted.

4 With all four fasteners in place, start at the front and push down and forward on the rail while tightening. Push down on the rear of the rail while tightening the fasteners.

5 Mark the holes for the drain tube using the provided template.

Attach the hoses onto the drain rails.

Insert the end of the drain hose into the drain hole.

! Drill 19mm (3/4") diameter holes in both front corners.

6 Repeat all of the steps for both sides. Return to the standard installation instructions. Follow step 2 for the bulkhead seal, then skip to step 8.

INSTALLATION SUPPLEMENT

This supplement replaces **steps 3-7** in the main install sheet for the vehicles noted. Read this guide before proceeding with the installation.

Honda Ridgeline 2017+
Page 2 of 2

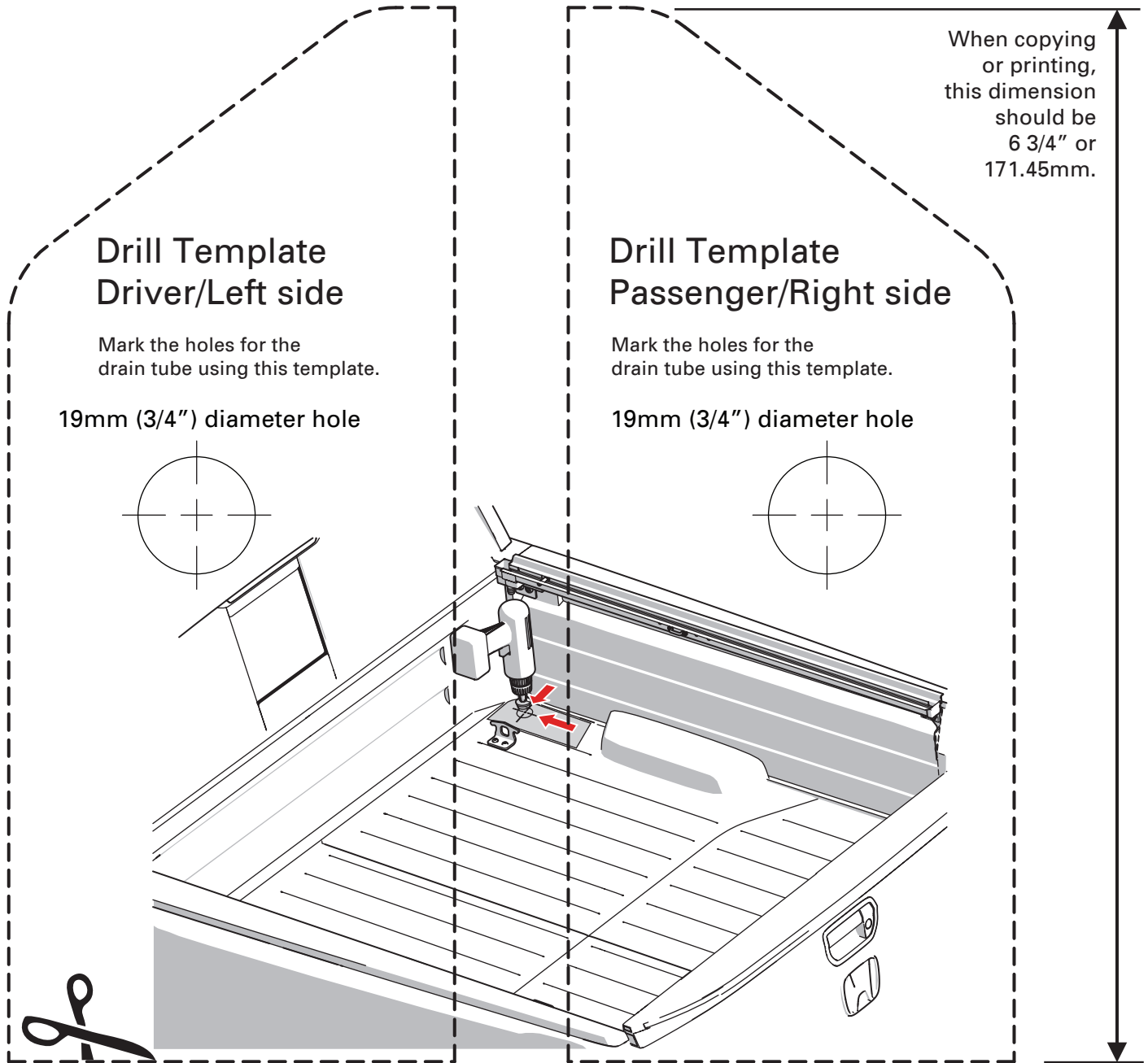

ENDURE ALX INSTALLATION SUPPLEMENT

This supplement replaces **steps 3-7** in the main install sheet for the vehicles noted. Read this guide before proceeding with the installation.

RamBox DT 2019+ Page 1 of 2

1 It is important that all areas where the bed cover mounts are clean and free of debris prior to installing.

Remove the factory accessory rails.

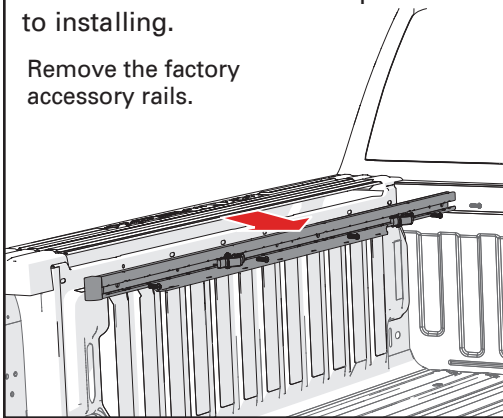

2 Apply the roll of flat seal along the bed to be between the bed and the factory accessory rail. Make sure the seal extends beyond the ends of the accessory rail, from the bulkhead through to the back corner trim cap. Do this for both sides.

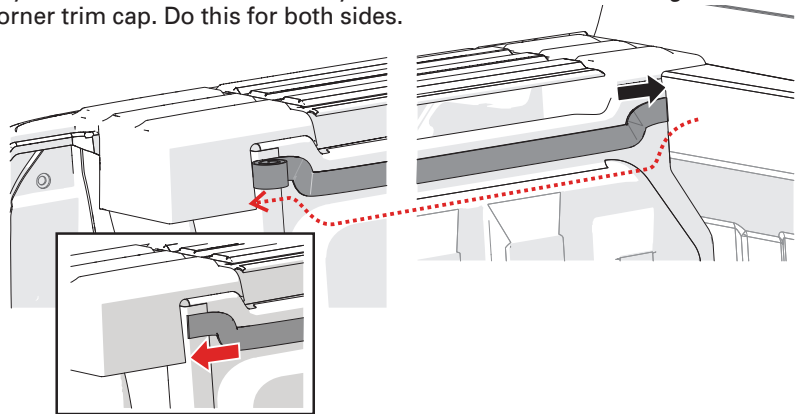

3 Continue to place the flat D-seal across the back end cap.

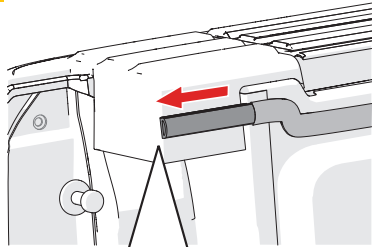

Trimming may be required.

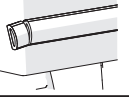

4 With the seals in place on both sides, reinstall the factory accessory rails.

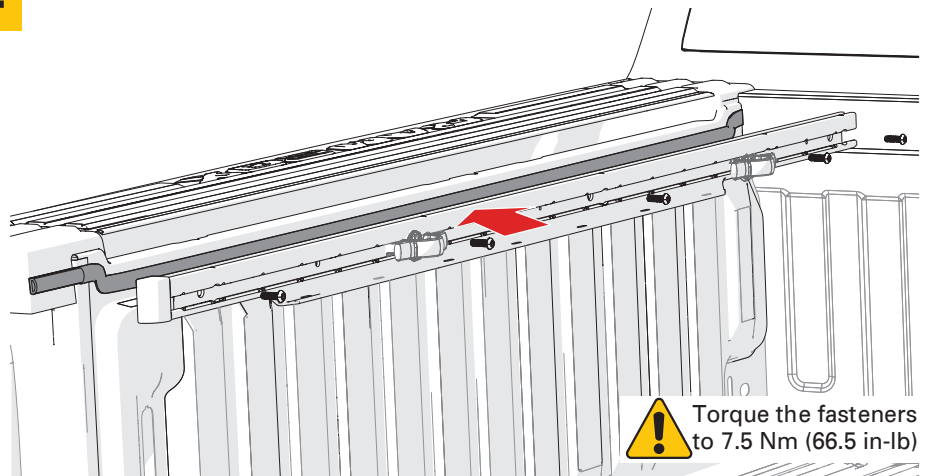

! Torque the fasteners to 7.5 Nm (66.5 in-lb)

5 **NOTE:** In the rail installation, the folding cover prop rod (A) and prop rod bracket (B) will conflict with the factory tie-down cleats (C & D). If a tie-down cleat is needed forward in the bed it can remain in the front (C). Otherwise the tie-down cleats need to be removed for rail installation.

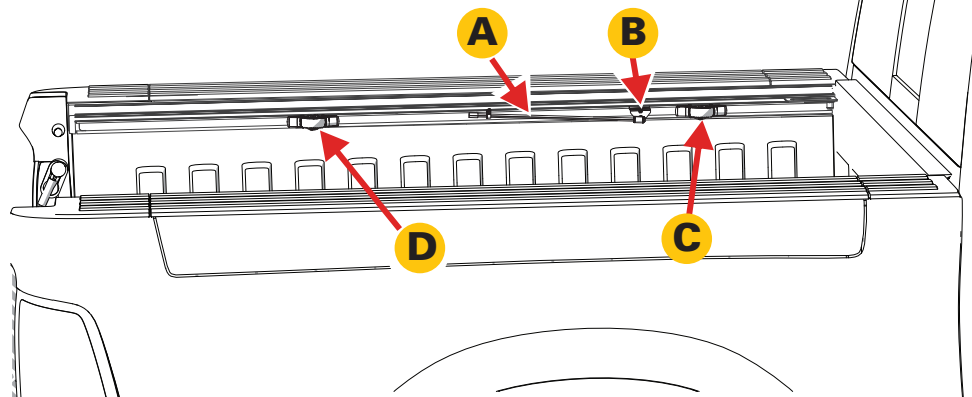

ENDURE ALX INSTALLATION SUPPLEMENT

This supplement replaces **steps 3-7** in the main install sheet for the vehicles noted. Read this guide before proceeding with the installation.

RamBox DT 2019+ Page 2 of 2

- 6** Remove the cargo rail end caps and tie-down cleats as noted in step 5.

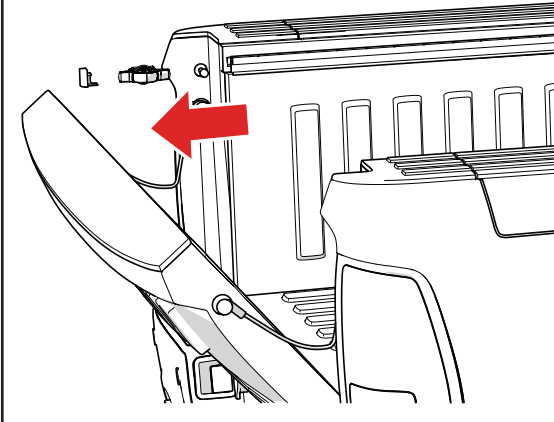

- 7** Slide the hard folding cover rails into the top of the cargo rails with the slotted bracket (E) in front and on the inside of the truck bed. The hard folding cover rails use the rounded clip ends (F) to spring into the cargo rail groove (G).

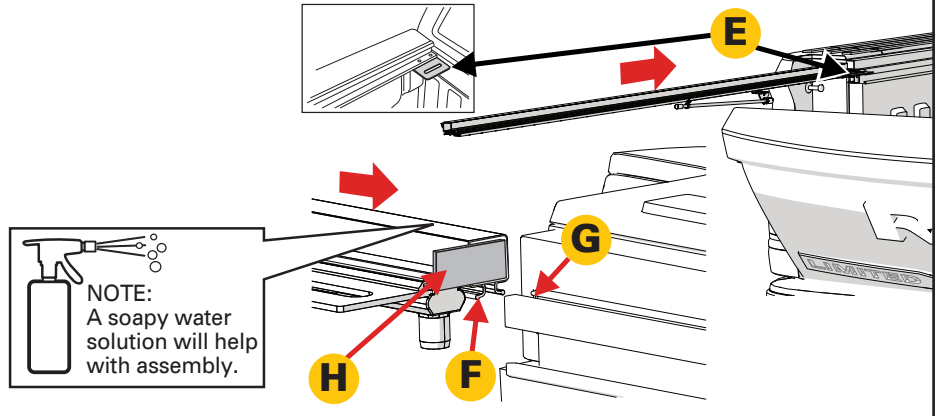

- 8** Slide the hard folding cover rails forward until the foam seal (H, from Step 7) contacts the bulkhead (I).

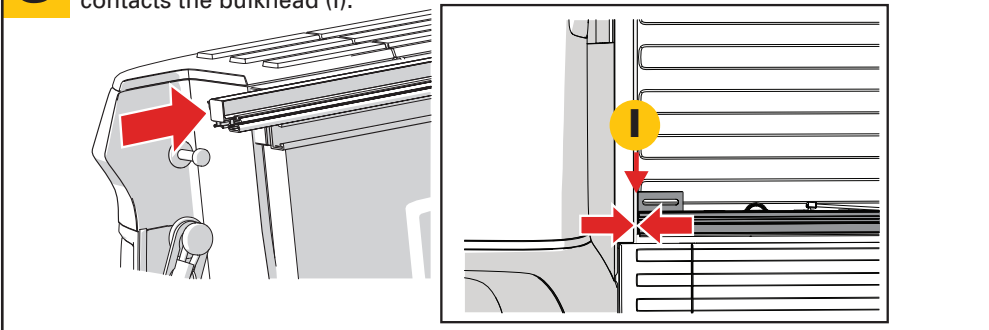

- 9** Replace the tie-down cleats and the cargo rail end caps, both sides.



- 10** Adhere the ribbed D-seal in the end cap corner to span the mounting rail caps and rear trim panel. Add one to each side. Trimming the seal may be required.

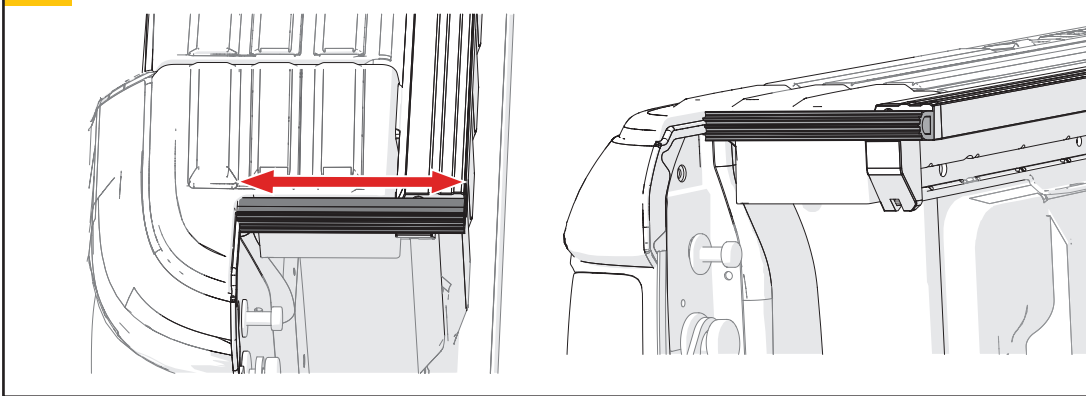

- 11** Repeat all of the steps for both sides. Return to the standard installation instructions. Follow step 2 for the bulkhead seal, then skip to step 8.

This supplement replaces **steps 3-7** in the main install sheet for the vehicles noted. Read this guide before proceeding with the installation.

Jeep Gladiator Page 1 of 4

It is important that all areas where the bed cover mounts are clean and free of debris prior to installing.

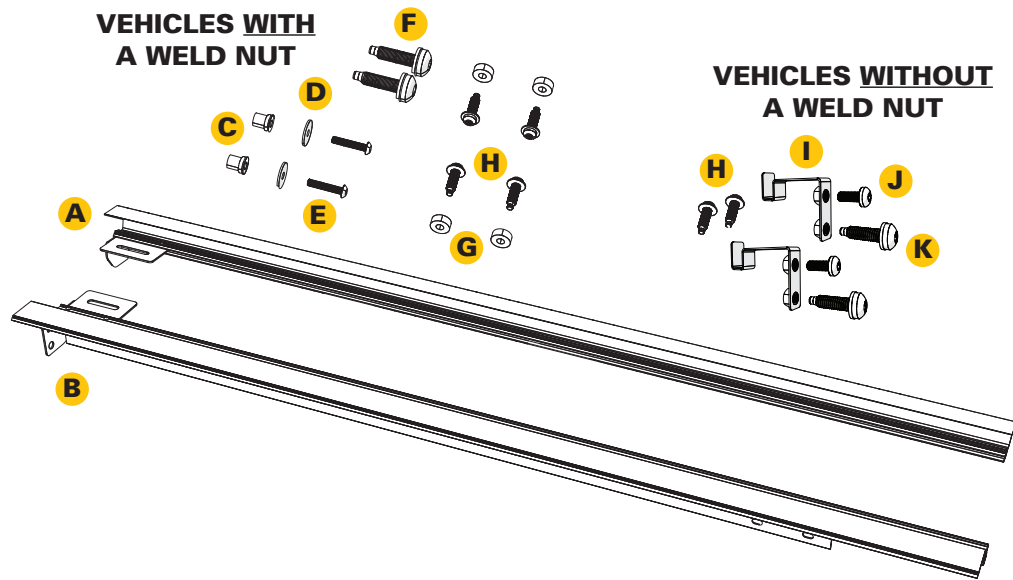

PARTS INCLUDED IN YOUR KIT

- A** 1x Passenger side cover rail
- B** 1x Driver side cover rail

VEHICLES WITH A WELD NUT

- C** 2x Well nuts
- D** 2x Washers
- E** 2x Hex button head screws
- F** 2x T-50 Torx head bolts
- G** 4x Spacers
- H** 4x M6 screws with washers

VEHICLES WITHOUT A WELD NUT

- H** 4x M6 screws with washers
- I** 2x Bulkhead brackets
- J** 2x M8 bolts T-45
- K** 2x M8 bolts T-50 with washers

TOOLS RECOMMENDED

- 7/8" (22mm) drill bit & drill
- T-50 Torx drive
- T-30 Torx drive
- T-45 Torx drive
- 1/8" Hex head wrench
- Utility knife or cutting tool

WITH WELD NUT

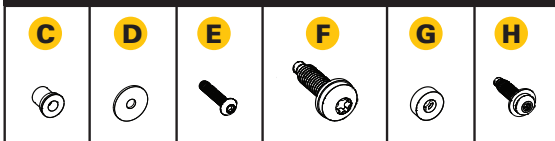

WITHOUT WELD NUT

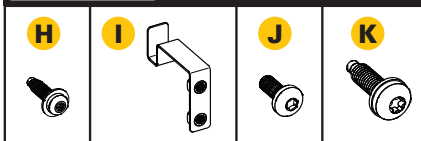

1 Drop-in Liner Trimming

If the truck has a drop-in bedliner, the top corners at the bulkhead, and the top corners of the tailgate liner need to be trimmed to allow for the bed cover rails.

CAUTION: Move the bedliner away from the truck sheet metal, or remove the liner from the truck so that the truck bed is not damaged.

Locate the necessary cuts by starting with the top left corner edge of the liner **1**, then measure a distance of 0.18", 4.8mm, outwards to establish point **A**. The first cut is down from **A** 2.5", 63.5mm, to point **B**. The next cut is from point **A**, inwards horizontally 2.6", 66.7mm, to point **C**. Cut from point **C** to **D**, then finish with a cut from **B** to **D**.

The cut is done on the passenger side as a mirror image, Figure 2.

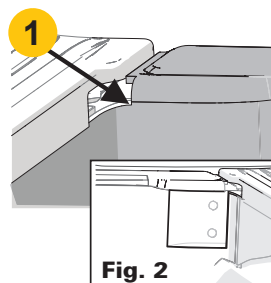
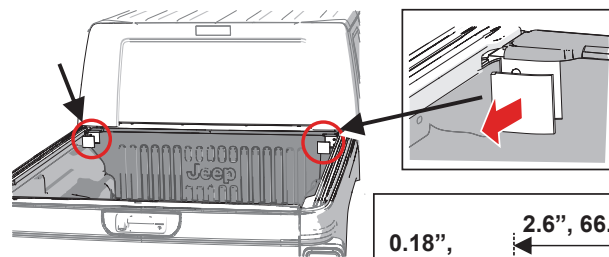
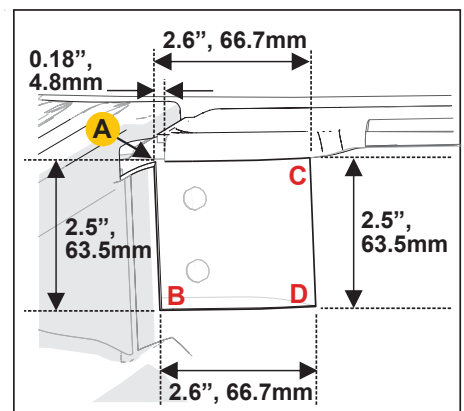

Fig. 2



This supplement replaces **steps 3-7** in the main install sheet for the vehicles noted. Read this guide before proceeding with the installation.

Jeep Gladiator Page 2 of 4

2 Locate the necessary cuts for the tailgate liner by starting with the outside corner of the liner, measure a distance of 0.375", 9.5mm inward, then 0.875", 22.2mm, down. The cut is done on both sides, as a mirror image.

CAUTION: Move the tailgate liner away from the truck sheet metal, or remove the liner from the truck so that the truck bed is not damaged.

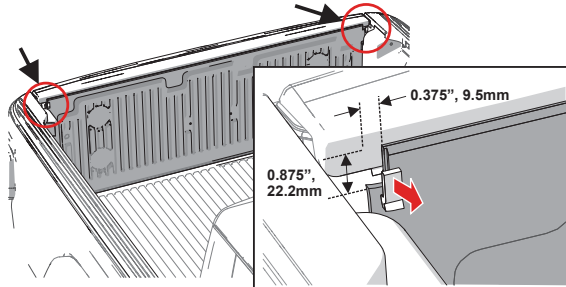

3 Holes are necessary in the drop-in bedliner for the bed cover rail drain tubes. A 7/8", [0.875", (22mm)], diameter hole needs to be centered on the first rib from the edge. The hole will be 2.875", 73mm, up from the floor. The hole is cut on both sides, as a mirror image.

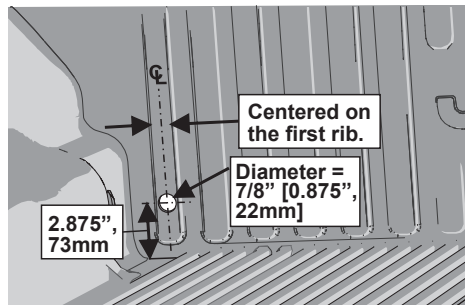

4 If the bed rail caps are not trimmed at the tailgate section, cut using the scribed lines as a guide to expose the area shown. Perform this operation on both sides of the pickup box.

NOTE: It is important that all areas where the bed cover mounts are clean and free of debris prior to installing.

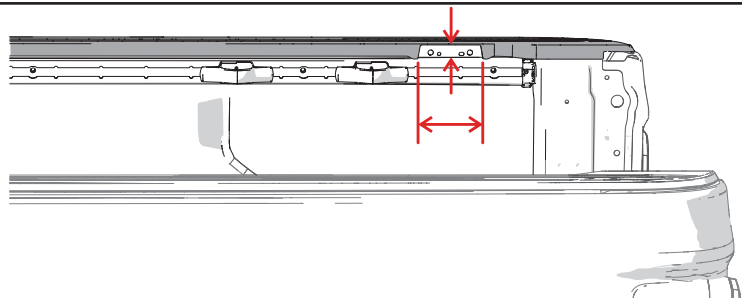

5 Identify the bulkhead hole configuration of your vehicle located near the cab.

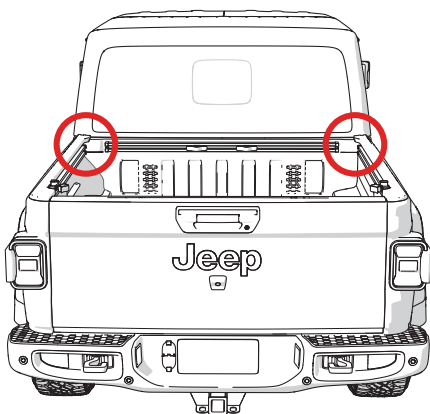

Vehicles WITH a weld nut

Weld nut VIN BX210534 and OLDER vehicles

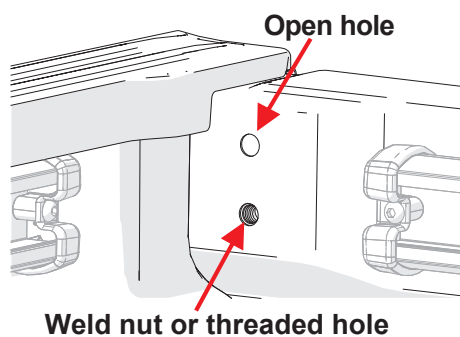

Vehicles WITHOUT a weld nut

NO weld nut VIN BX210535 and NEWER vehicles

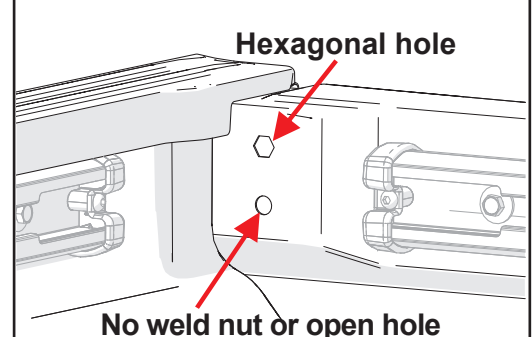

This supplement replaces **steps 3-7** in the main install sheet for the vehicles noted. Read this guide before proceeding with the installation.

Jeep Gladiator Page 3 of 4

WITH WELD NUT- STEPS 6-12

6 For vehicles with a spray-in bedliner, the threaded area in the bulkhead must be cleared of liner material.

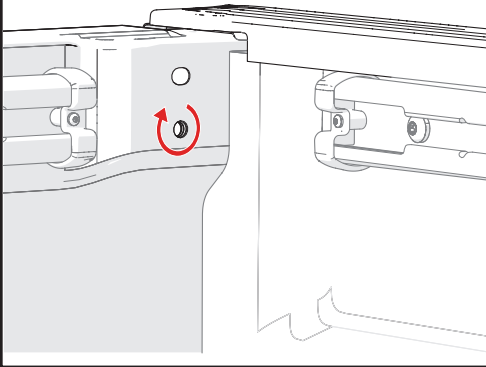

7 On the passenger side cover rail (A), thread the button head screw (E) through the washer (D), through the top hole in the bracket and into the well nut (C). Repeat on the driver's side cover rail (B).

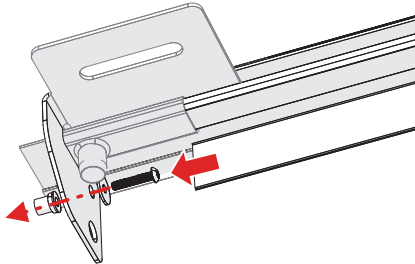

Note: Assemble just until contact is made, do NOT tighten the well nut.

8 Insert the M6 screw & washer (H) into one of the rear rail mounting holes on the passenger side cover rail (A). Slide a spacer (G) onto the threaded portion of the screw (H). Repeat for the second rear mounting hole, then repeat on the driver side cover rail (B).

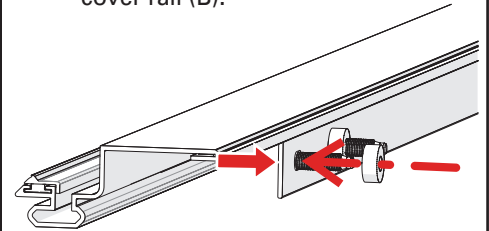

9 Place the cover rail (A & B) onto the bed rail and slide it forward, using the well nut (C) as a guide into the bulkhead opening.

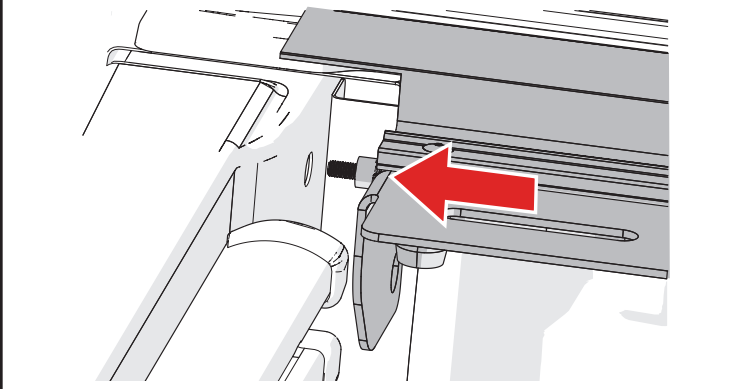

10 At the tailgate, thread the M6 screw & washers (H) from step 8, into the threaded inserts in the bed wall. Install with a T-30 Torx wrench. Leave the bolts loose until the cab bolts have been installed and tightened.

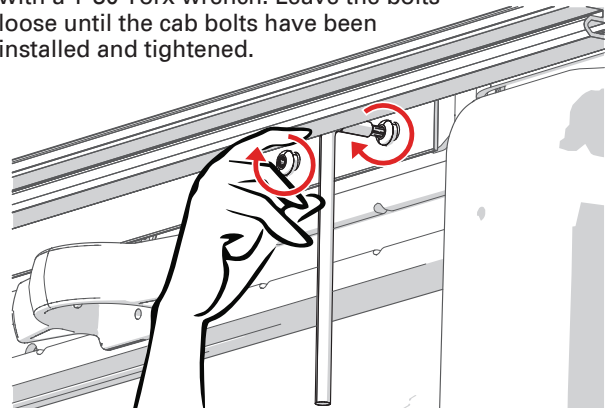

11 Thread the T-50 Torx head bolt (F) through the bottom hole of the cover rail bracket, and tighten it to 17.5 Nm/12.9 ft/lbs on both sides. Snug up the upper button head screw (E) in the well nut (C).

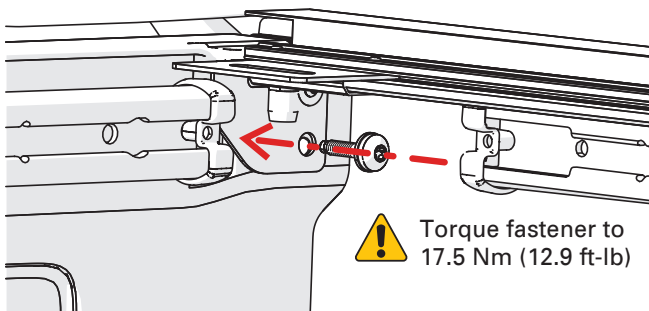

12 Tighten the M6 screw & washers (H), on both driver and passenger's sides. While tightening the screws, push down on the tailgate end of the rail. Ensure that the screws are fully tightened and that the rail does not move back and forth when force is applied.

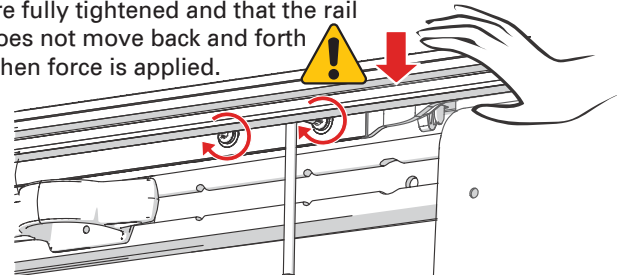

Make sure all of the steps are completed for both sides of the bed. Return to the standard installation instructions.

This supplement replaces **steps 3-7** in the main install sheet for the vehicles noted. Read this guide before proceeding with the installation.

WITHOUT WELD NUT- STEPS 13-18

13 Insert the M6 screw & washer (H) into one of the rear rail mounting holes on the passenger side cover rail (A). Slide a spacer (G) onto the threaded portion of the screw (H). Repeat for the second rear mounting hole, then repeat on the driver side cover rail (B).

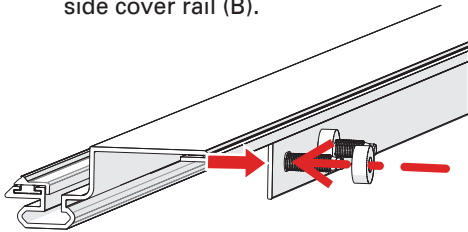

14 Place the passenger side cover rail (A) onto the bed rail and slide it forward up against the bulkhead. Lower the bulkhead bracket (I) between the truck cab and the front of the bulkhead so that the threads of the bulkhead bracket (I) align with the two open holes in the bulkhead.

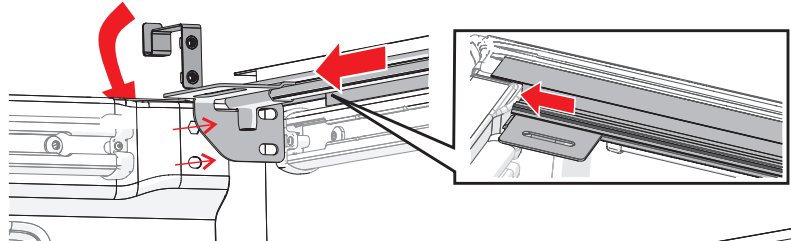

Thread the T-50 bolts with washers (K) into the lower hole of the bed rail and the bulkhead bracket (I). Do NOT fully tighten the bolts. Repeat on the driver's side cover rail (B).

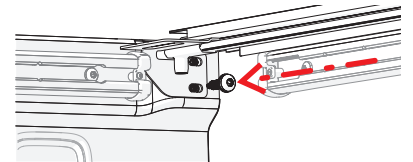

15 At the tailgate, thread the screws (H) installed into the rail from step 13, into the threaded inserts in the bed wall. Install with a T-30 Torx wrench. Leave the bolts loose until the screws for the bulkhead have been tightened. Repeat on the driver's side.

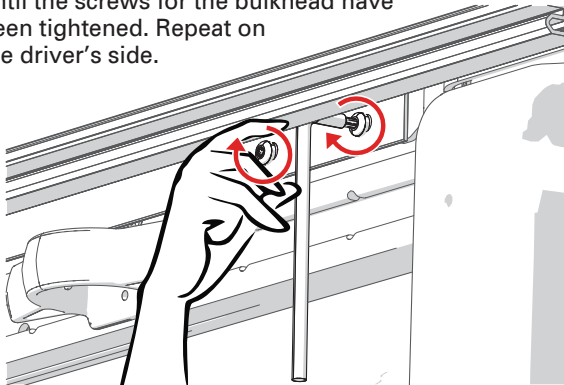

16 Install the small T-45 bolts (J) into the upper hole of the bed rail and the bulkhead bracket (I). Tighten both bolts (J & K), repeat on the driver's side.

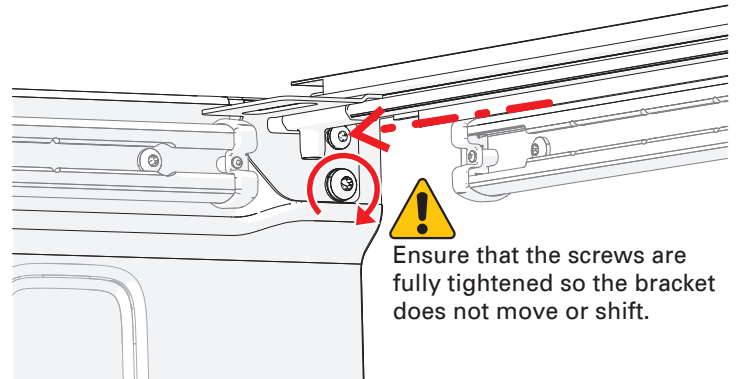

Ensure that the screws are fully tightened so the bracket does not move or shift.

17 Tighten the screw and washers (H) at the tailgate with the T-30 Torx wrench. While tightening the bolts, push down on the rear/tailgate end of the rail. Tighten the screws on the driver side. Ensure that the screws are fully tightened so the rail does not move or shift.

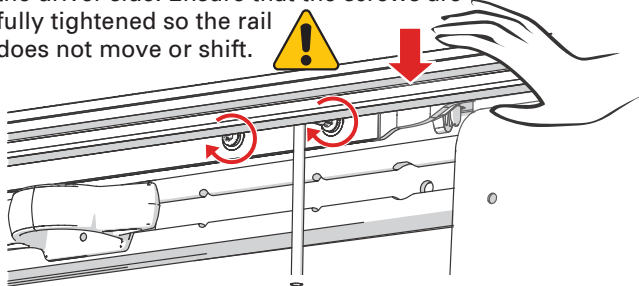

18 Make sure all of the steps are completed for both sides of the bed. **Return to the standard installation instructions.**

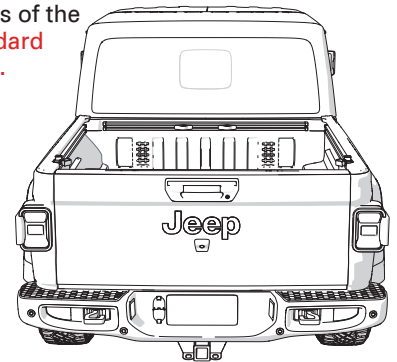

This supplement replaces **steps 3-7** in the main install sheet for the vehicles noted. Read this guide before proceeding with the installation.

GM CarbonPro bed Page 1 of 2

TOOLS REQUIRED

- 10mm open end wrench
- Drill
- 7mm, (9/32") drill bit
- 22.3mm (7/8") drill bit
- Utility knife or cutting tool

TOOLS RECOMMENDED

- Trim stick

It is important that all areas where the bed cover mounts are clean and free of debris prior to installing.

PARTS INCLUDED IN YOUR KIT

- A** 1x Driver side cover rail
- B** 1x Passenger side cover rail
- C** 10x U-nuts
- D** 10x M6 bolt
- E** 2x Bed cap hole guide
- F** 2x Drain hoses (from main kit)

1 U-nut installation

Insert the U-nuts (C) by prying the plastic truck bed cap away from the truck bed. The U-nut fit underneath the plastic truck bed cap and onto the carbon side (Fig. 1). Make sure that the U-nut is aligned with the bed rail hole as shown in Fig. 2. Repeat for the passenger side.

The plastic truck bed cap is removed for illustration purposes.

Install 5 U-nuts into each of the slots, and on both sides of the truck bed.

NOTE: A trim stick (not shown) is useful for prying out the plastic truck bed cap.

2 Drill mounting holes

Slide the bed cap hole guide (E) onto the edge of the plastic truck bed cap and in between the cap and the bed (Fig. 3). Align the guide so that its back fits into the hole of the U-nut (Fig. 4). Drill a 7mm, (9/32") hole through the plastic truck bed cap using the bed cap hole guide (Fig. 5). The back of the guide will prevent the drill from hitting the truck bed. Repeat this for every U-nut location on both sides of the truck bed.

The plastic truck bed cap is shown as a dotted line so that the placement of the U-nut underneath can be shown.

This supplement replaces **steps 3-7** in the main install sheet for the vehicles noted. Read this guide before proceeding with the installation.

GM CarbonPro bed
 Page 2 of 2

3 Rail installation - Thread the M6 bolts (D) through the drilled holes and into the U-nuts until they are spaced approximately 3.18mm (1/8") from the bed cap (Fig. 6). Place the driver side cover rail (A) by aligning the slots onto each of the bolts (Fig. 7). Push down on the cover rail to help the seals set to the truck bed cap and tighten the bolts with the 10mm open end wrench. Repeat the steps for the passenger side cover rail (B).

Ensure that the screws are fully tightened so the rail does not move or shift.

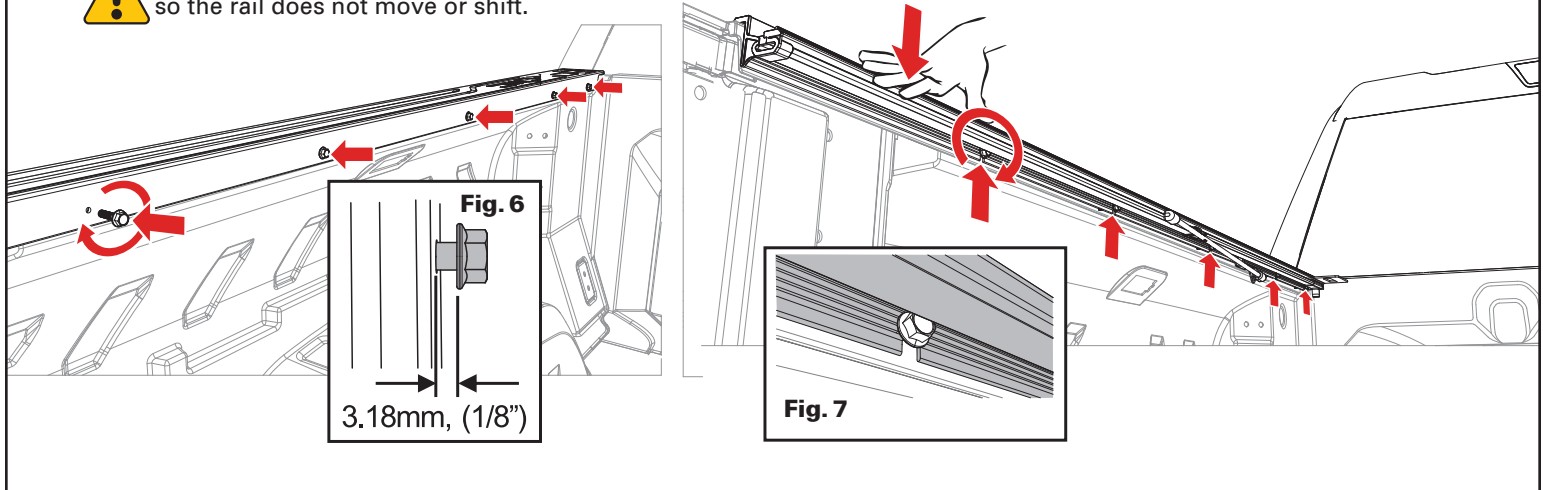

4 Drill drain hole & install drain tube
 Drill a 22.3mm, (7/8") hole through the truck bed liner at the center of the existing circular divot as shown. Drill the hole on both the driver and passenger side.

Be careful to only drill through the outer liner.

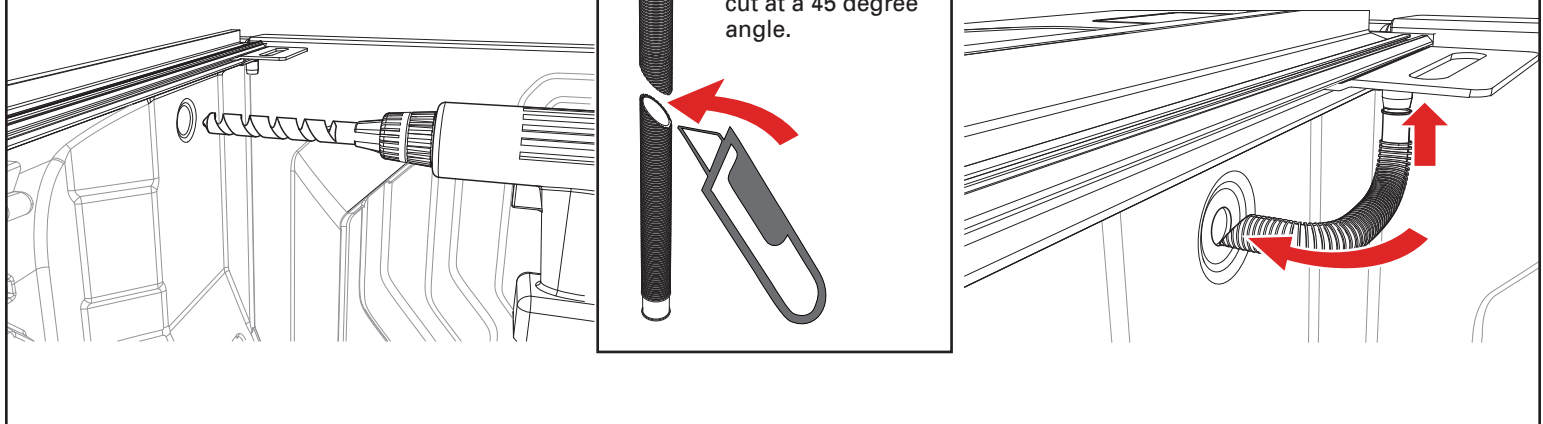

The drain hoses are included in the standard install kit.

A single drain hose is cut in half for this install, make the cut at a 45 degree angle.

Insert the cut end of one half of the drain hose (F) into the drilled hole in the bed. Push the hose into the hole with the diagonal cut as shown for the driver side. Slide the collared end of the hose onto the cover rail drain. Install the other half of the hose on the passenger side in the same manner.

5 Repeat all of the steps for both sides. Return to the standard installation instructions. Follow step 2 for the bulkhead seal, then skip to step 8.

This supplement replaces **steps 3-7** in the main install sheet for the vehicles noted. Read this guide before proceeding with the installation.

Ford Ranger 2024-2025
 Page 1 of 3

PARTS INCLUDED IN YOUR KIT

- A** 2x Female Buckle
- B** 1x Clamp Pack (6 clamps)
- C** 2x Drain Tube Bed Plugs

TOOLS RECOMMENDED

- Scissors or utility knife
- T30 Torx screwdriver or bit
- Isopropyl alcohol

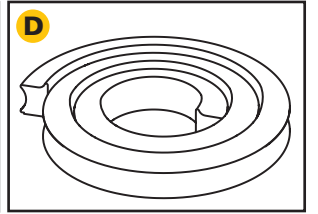
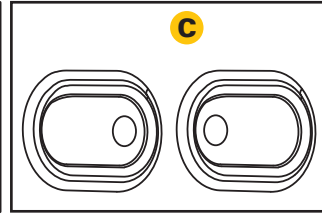
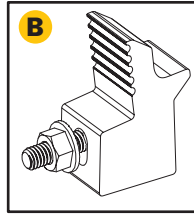
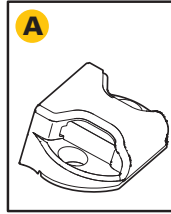

1 Remove plastic clips - Remove the three plastic clips from the passenger and driver side bed caps, store them in a plastic bag and put them in your glove box of vehicle.

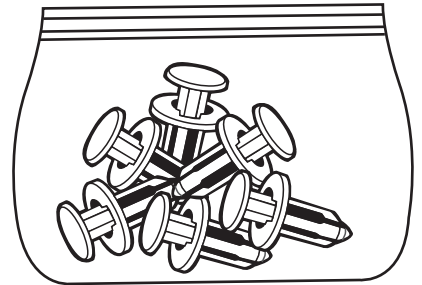

2 Install bulkhead seal - Clean the top of the bulkhead where the seal will go with soap and water to remove dirt and debris. Then clean the same area with isopropyl alcohol to remove wax or grease and to evaporate any remaining water. Allow the surface to dry. Peel the backing paper from the seal and apply pressure to the entire seal to make sure the adhesion is good. The seal should be flush with the front edge of the bulkhead and the seal should be snug between the bed rail caps. If the bulkhead seal is too long, you may need to cut it shorter so that it sits snug between the bed caps.

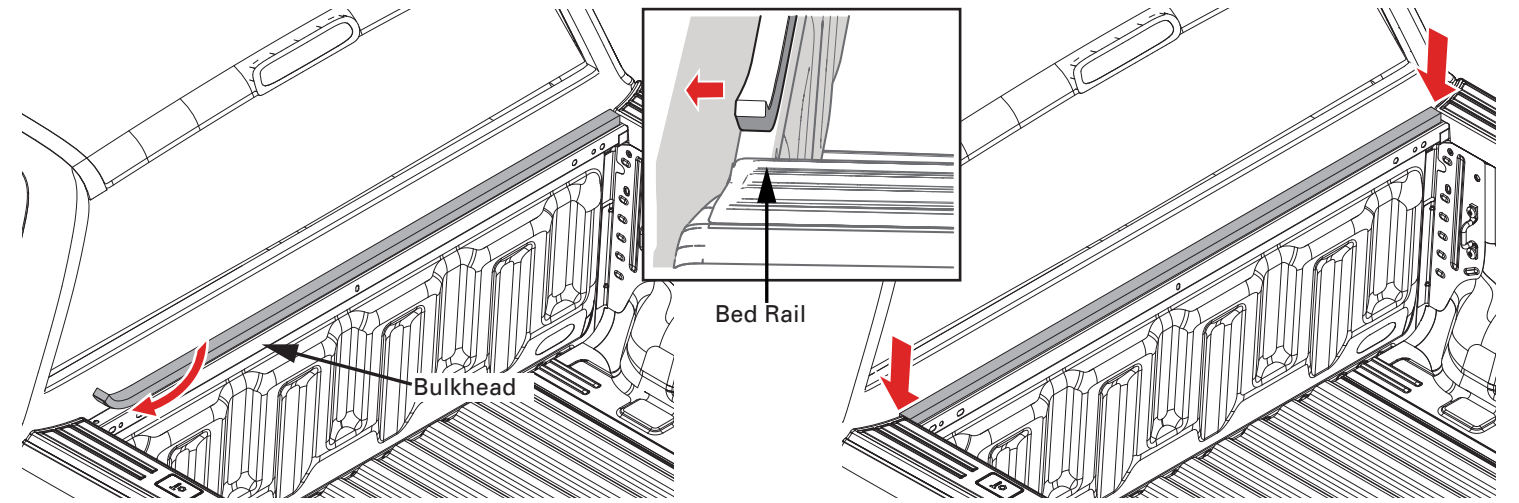

INSTALLATION SUPPLEMENT

This supplement replaces **steps 3-7** in the main install sheet for the vehicles noted. Read this guide before proceeding with the installation.

Ford Ranger 2024-2025

Page 2 of 3

3 Rail installation - Place the rail on the truck bed cap. The slotted bracket will be in the front toward the bulkhead. Check that the rail sits properly on the bed cap and that the rubber flap seal is flat on the bed cap. Remove the rail and repeat on the other side.

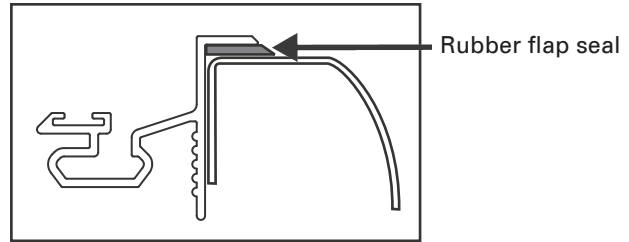
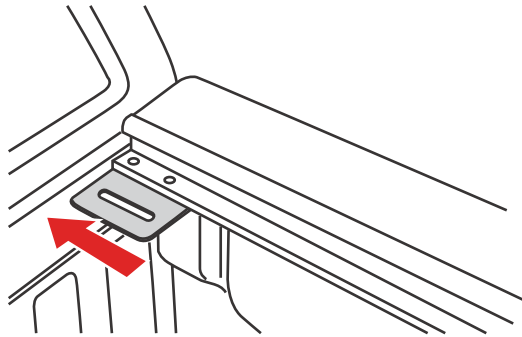

4 Rail clamp installation - Install the clamps, bolts and nuts provided on passenger and driver side bed caps where you removed the three plastic clips in step 1. Make sure the bottom of the rail is between the clamps and the plastic rail cap. Also make sure the nut is behind the sheet metal. Hand tighten to hold the clamps in place.

Installing Clamp

Installing Rail

Tightening Bolt

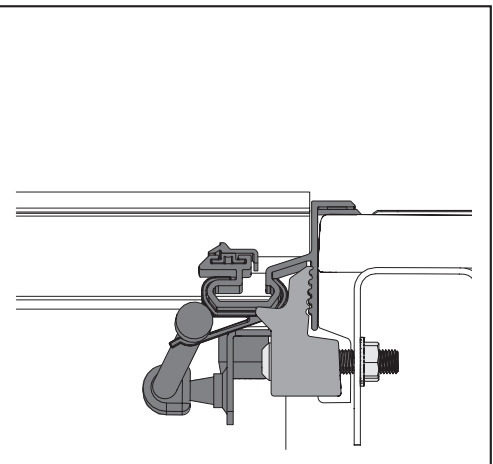
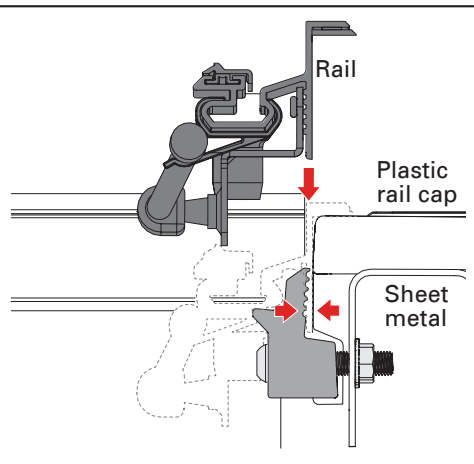
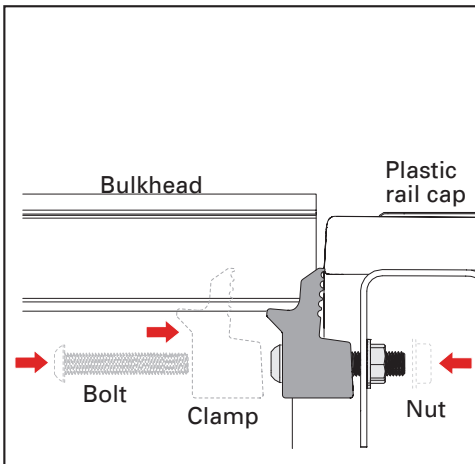

Front/Cab

Rear/Tailgate

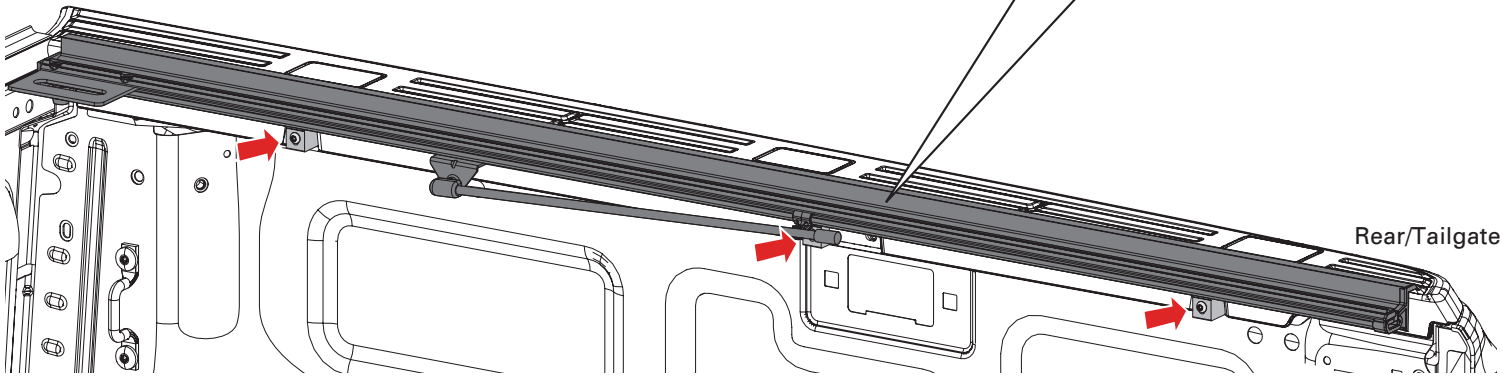

INSTALLATION SUPPLEMENT

This supplement replaces **steps 3-7** in the main install sheet for the vehicles noted. Read this guide before proceeding with the installation.

Ford Ranger 2024-2025

Page 3 of 3

- 5 Rail clamp installation** - Starting with the front clamp, make sure the rail is pushed forward against the bulkhead, and square with the bed rail. Apply downward pressure on the rail and pull the rail towards the sides of the bed, while tightening the bolt with a T30 Torx bit to 8 ft.lbf/11 N.m. Repeat with the middle and then rear clamp, making sure the rail is square and flat with the bed rail.

 Torque fastener to 11 Nm (8 ft-lb)

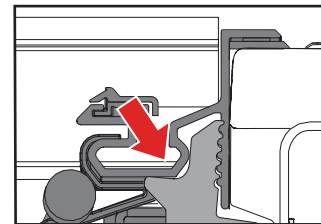
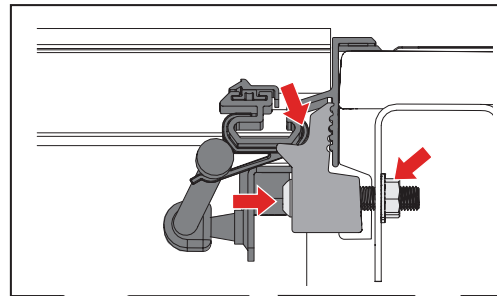
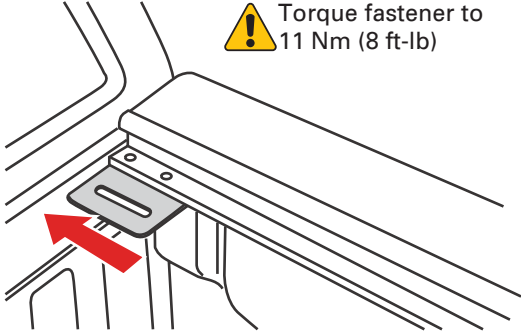

NOTE: The rail should make good contact with the top face of the clamp after tightening.

Front/Cab

Rear/Tailgate

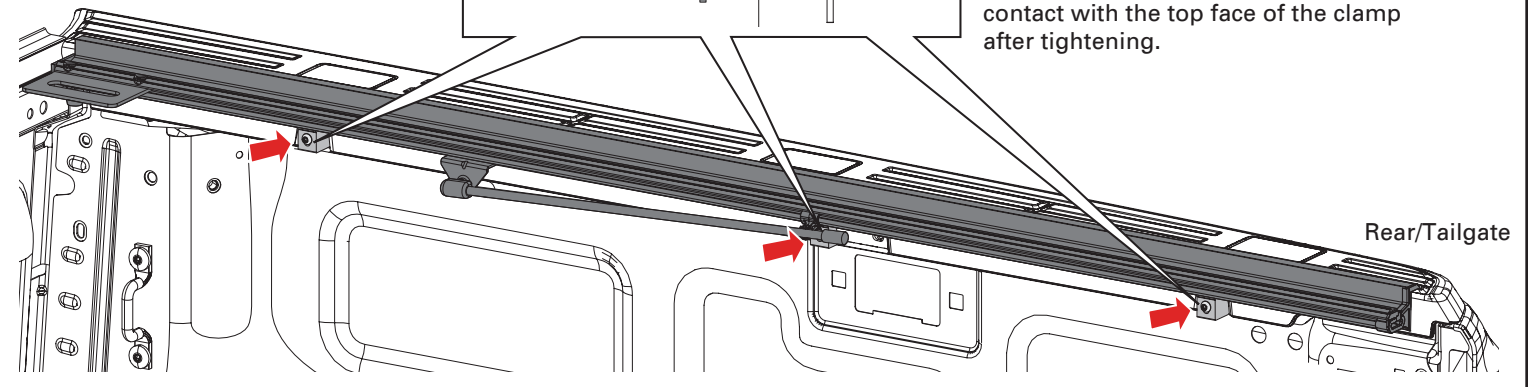

- 6** Repeat all of the steps for both sides. Return to standard installation instructions, step 7.

This supplement replaces **steps 3-7** in the main install sheet for the vehicles noted. Read this guide before proceeding with the installation.

Ford Ranger 2026+ Page 1 of 3

PARTS INCLUDED IN YOUR KIT

- A** 2x Female Buckle
- B** 1x Clamp Pack (6 clamps)
- C** 2x Drain Tube Bed Plugs
- D** 1x Bulkhead Seal

TOOLS RECOMMENDED

- Scissors or utility knife
- T30 Torx screwdriver or bit
- Isopropyl alcohol

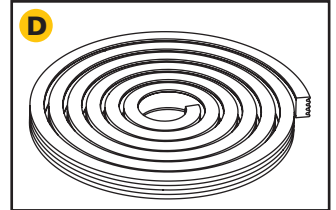
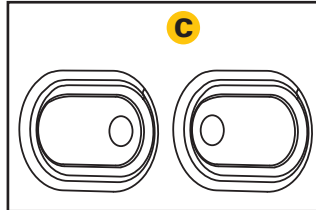
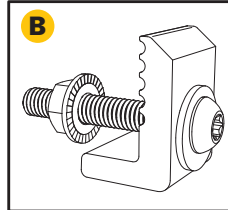
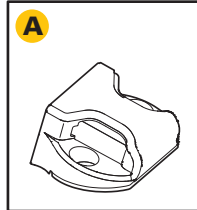

1 **Remove plastic clips** - Remove the three plastic clips from the passenger and driver side bed caps, store them in a plastic bag and put them in your glove box of vehicle.

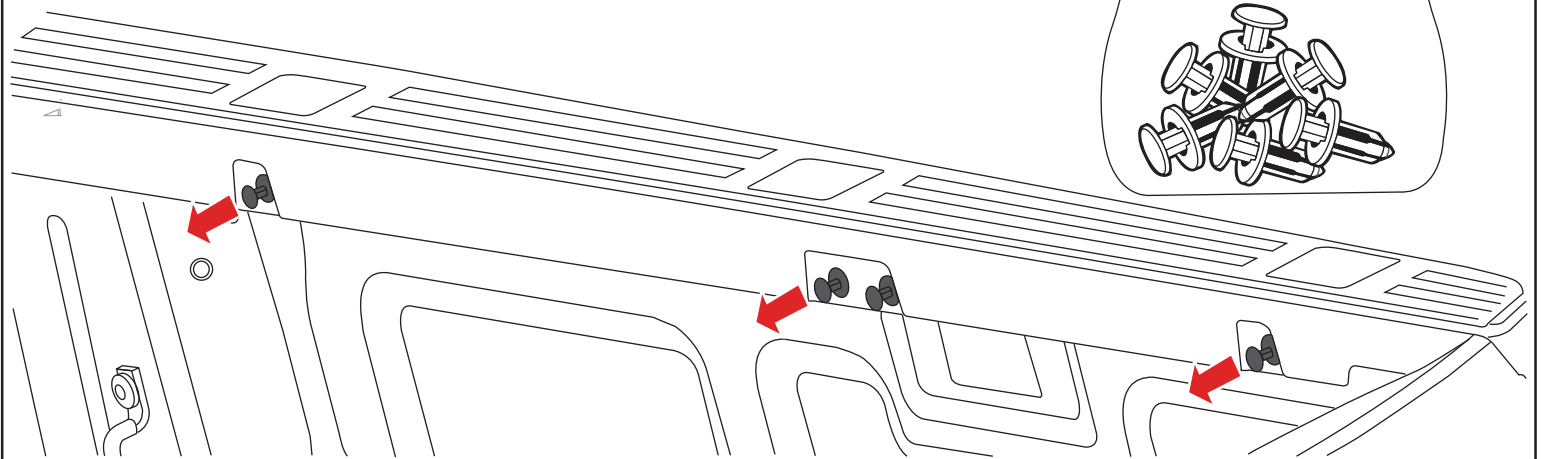

2 **Install bulkhead seal** - Clean the top of the bulkhead where the seal will go with soap and water to remove dirt and debris. Then clean the same area with isopropyl alcohol to remove wax or grease and to evaporate any remaining water. Allow the surface to dry. Peel the backing paper from the seal and apply pressure to the entire seal to make sure the adhesion is good. The seal should be flush with the front edge of the bulkhead and the seal should be snug between the bed rail caps. If the bulkhead seal is too long, you may need to cut it shorter so that it sits snug between the bed caps.

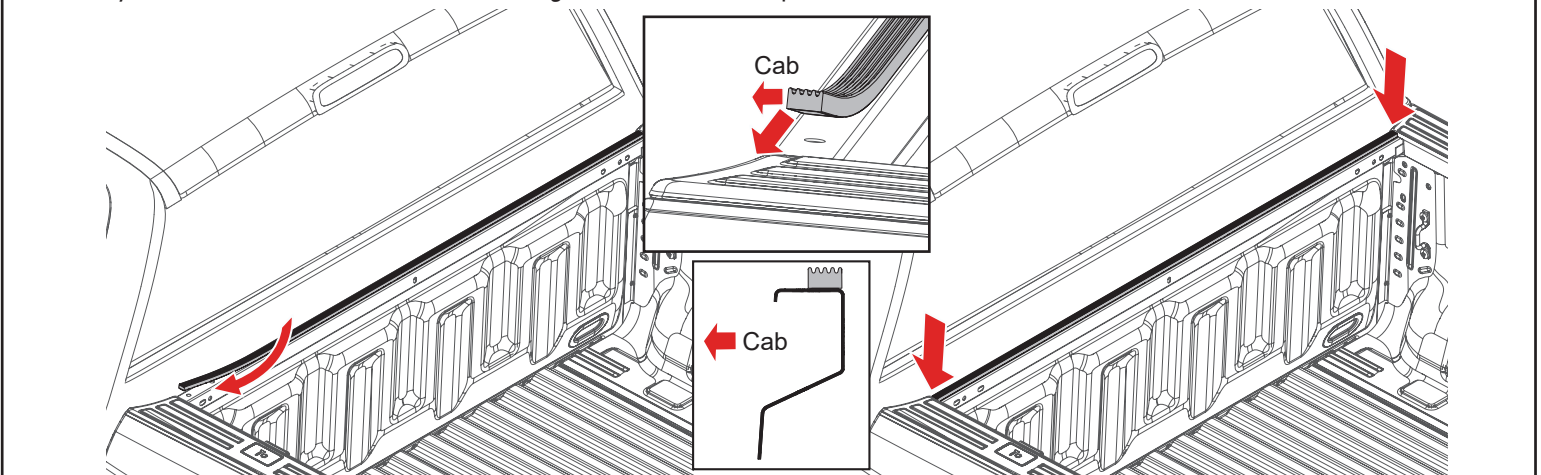

This supplement replaces **steps 3-7** in the main install sheet for the vehicles noted. Read this guide before proceeding with the installation.

Ford Ranger 2026+
 Page 2 of 3

3 Rail installation - Place the rail on the truck bed cap. The slotted bracket will be in the front toward the bulkhead. Check that the rail sits properly on the bed cap, the rail slots line up with the bed cap holes, and that the rubber flap seal is flat on the bed cap. Remove the rail and repeat on the other side.

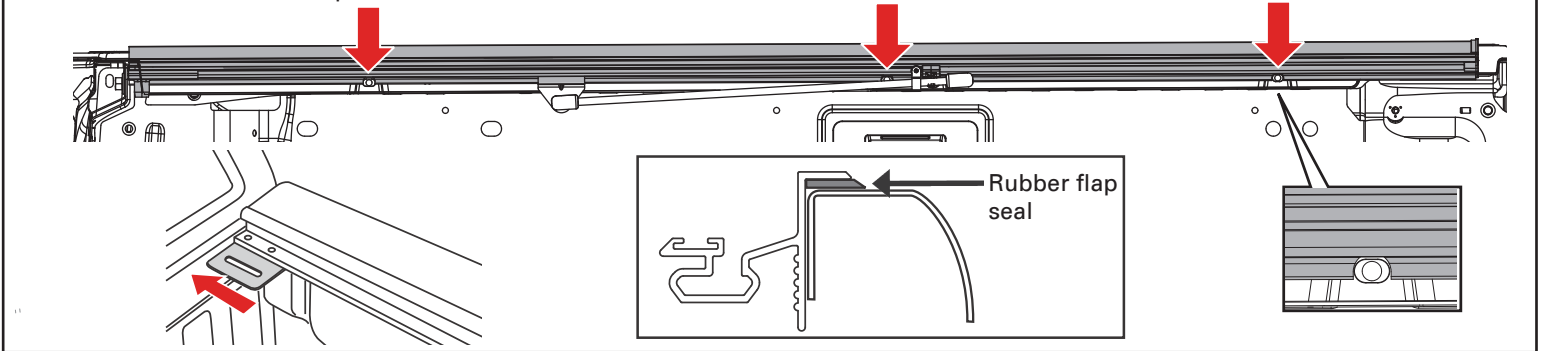

4 Rail clamp installation - Install the bolts, washers, clamps, and nuts provided on the passenger and driver side bed caps where you removed the three plastic clips in step 1. Ensure that the clamp fingers mate properly to the rail, and that the bottom leg of the clamp seats properly to the bed plastic. Also make sure the nut is behind the sheet metal. Hand tighten to hold the clamps in place.

Installing Clamp

Installing Rail

Tightening Bolt

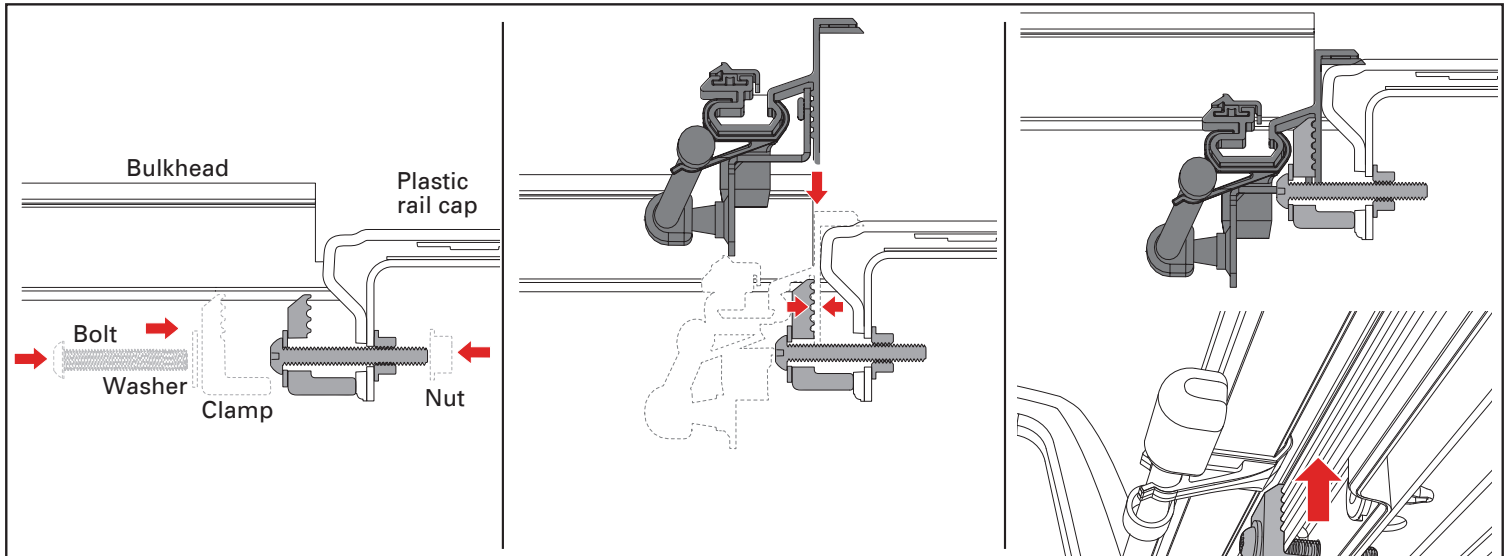

Front/Cab

Rear/Tailgate

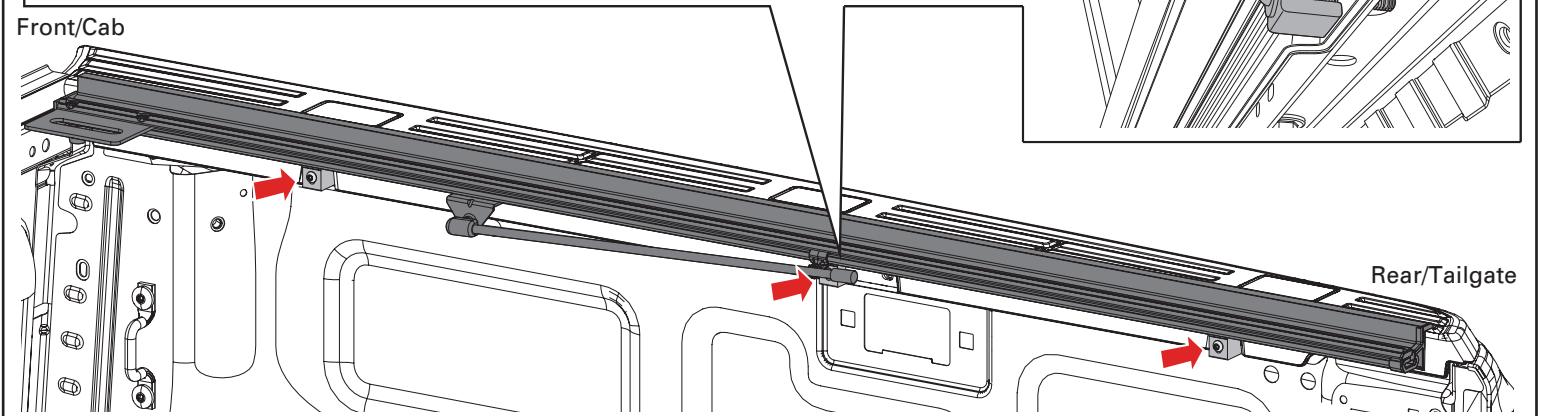

INSTALLATION SUPPLEMENT

This supplement replaces **steps 3-7** in the main install sheet for the vehicles noted. Read this guide before proceeding with the installation.

Ford Ranger 2026+ Page 3 of 3

5 Rail clamp installation - Starting with the front clamp, make sure the rail is pushed forward against the bulkhead, and square with the bed rail. Apply downward pressure on the rail and pull the rail towards the sides of the bed, while tightening the bolt with a T30 Torx bit to 8 ft.lbf/11 N.m. Repeat with the middle and then rear clamp, making sure the rail is square and flat with the bed rail.

 Torque fastener to 11 Nm (8 ft-lb)

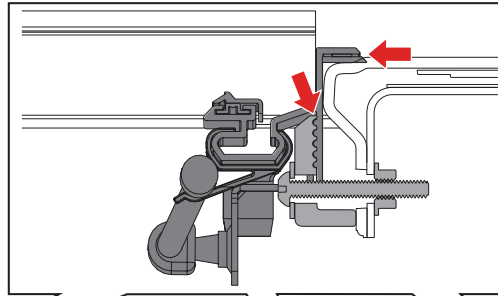
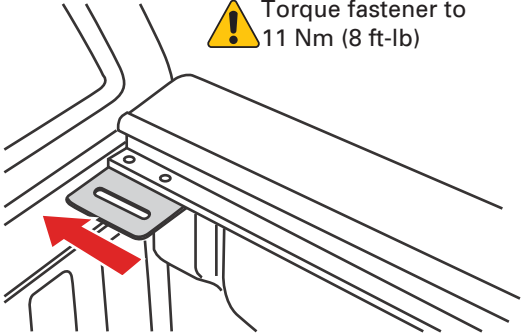

NOTE: The rail should make good contact with the grooves of the clamp after tightening.

Front/Cab

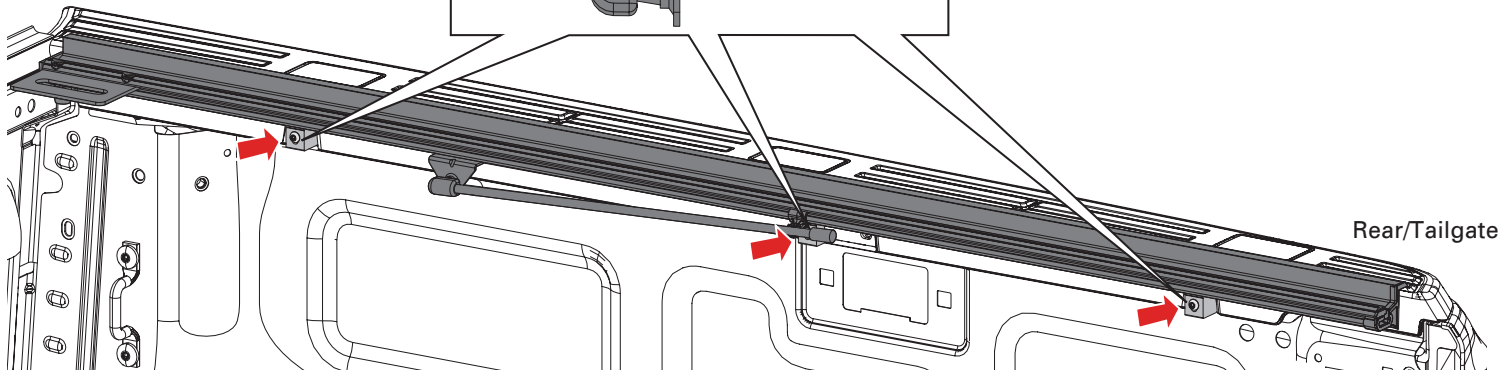

Rear/Tailgate

6 Repeat all of the steps for both sides. Return to standard installation instructions, step 7.