

# EGR INSTALLATION INSTRUCTIONS

## Tools Required

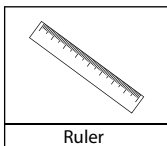

## Cleaning Notes

- Spray with a firm water spray to remove any loose dirt.
- Wash with water, detergent and a soft cloth or sponge.
- Do not use petroleum based solvents or abrasives.
- Do not drive for four hours after installation.
- Do not use automatic car wash.

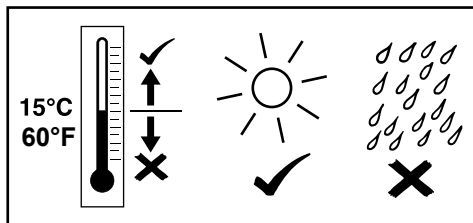
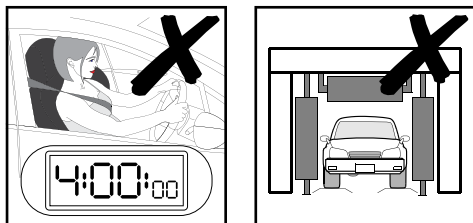

• For Technical Support/Warranty Information please call: 800-757-7075

1. Clean and dry the upper front LHS door frame prior to fitment. Wind the window down and trial fit the slimline weathershield onto the front door frame. Using a ruler, align the rear edge of the slimline weathershield 90mm ( $3\frac{55}{64}$ ) forward from the rear edge of the door frame. Align the top edge of the slimline weathershield 30mm ( $1\frac{3}{16}$ ) down from the top edge of the door frame. Note the tape attachment areas.

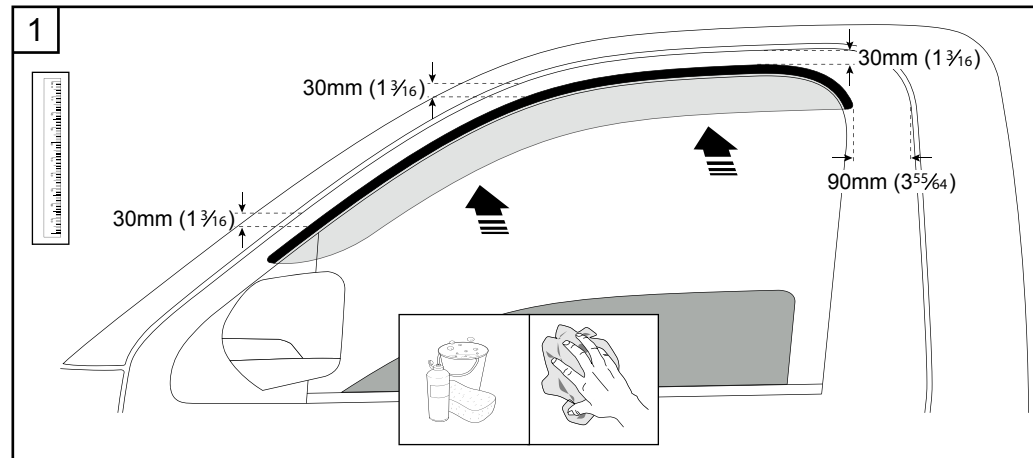

2. Clean the tape attachment areas on the door frame thoroughly with the alcohol prep pad provided. Wipe dry with a clean, dry cloth.

**IMPORTANT: DOOR FRAME MUST BE CLEAN PRIOR TO INSTALLING PART ON THE DOOR FRAME. FAILURE TO CLEAN WILL RESULT IN REDUCED TAPE ADHESION TO THE DOOR FRAME.**

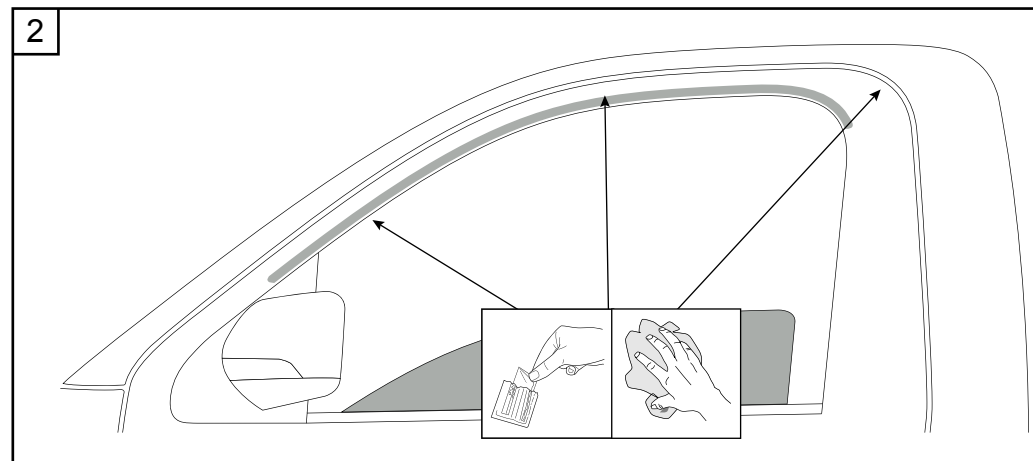

3. Peel back approximately 50mm (2") of the protective tape liner on the backing tape from each of the tape sections and fold the protective liner at 45° to the outside of the slimline weathershield. **IMPORTANT: DO NOT TOUCH THE EXPOSED SURFACE OF THE BACKING TAPE.**

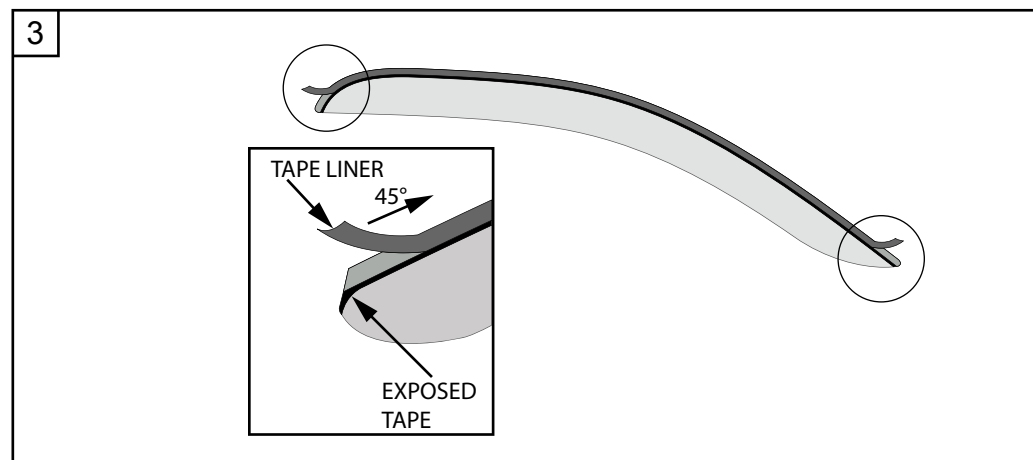

# EGR INSTALLATION INSTRUCTIONS

**Tools Required**

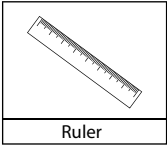

**Cleaning Notes**

- Spray with a firm water spray to remove any loose dirt.
- Wash with water, detergent and a soft cloth or sponge.
- Do not use petroleum based solvents or abrasives.
- Do not drive for four hours after installation.
- Do not use automatic car wash.

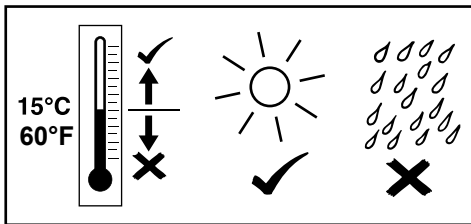
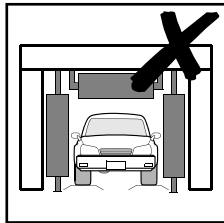

• For Technical Support/Warranty Information please call: 800-757-7075

- 4• Position the slimline weathershield on the door frame. Double check the positioning of the slimline weathershield following the dimensions shown in step1, then apply light pressure to the tape areas.

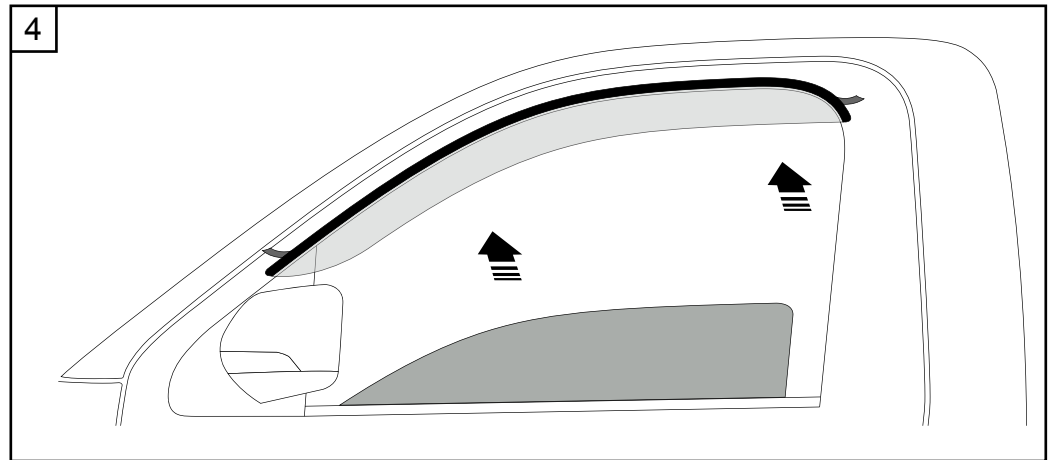

- 5• Slowly peel the remaining protective tape liner away by pulling on the exposed ends of liner, and apply firm pressure around the attachment areas.

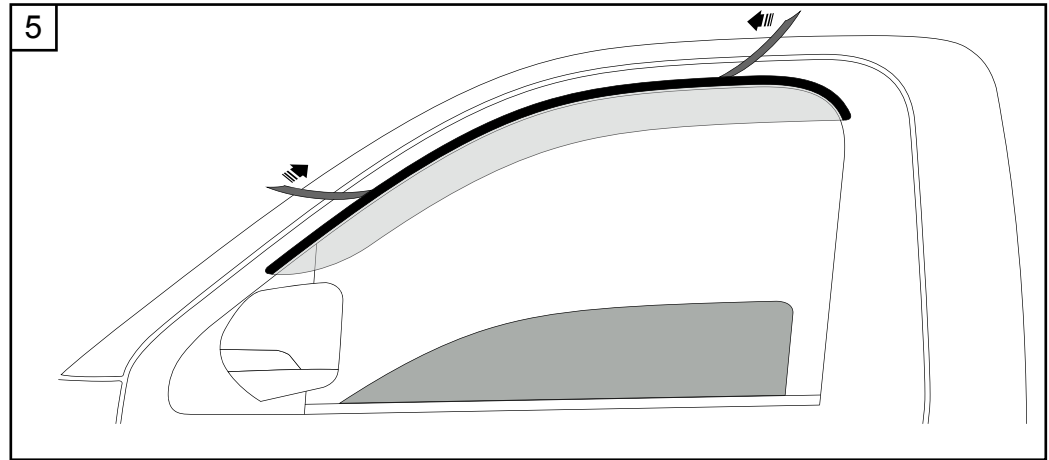

- 6• Using a clean, soft cloth, firmly rub down over the attachment areas 4 times to ensure maximum adhesion.

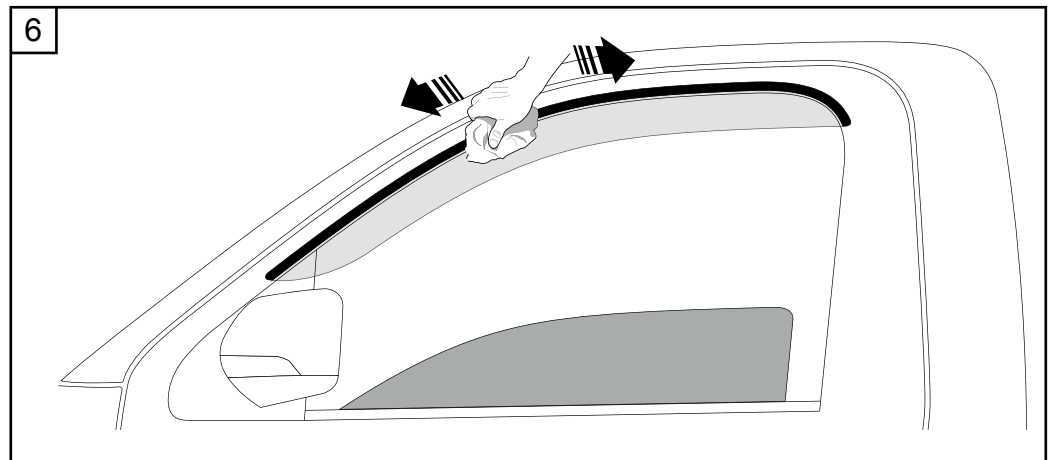

Repeat the previous steps for right hand side to complete the installation of slimline weathershields.

# EGR DIRECTIVES D'INSTALLATION

## Outils nécessaires

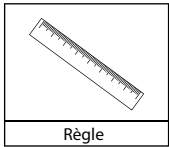

## Remarques sur le nettoyage

- Attendre au moins quatre heures après l'installation avant de conduire.
- Ne pas utiliser un lave-auto automatique.

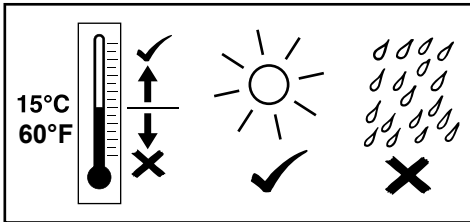
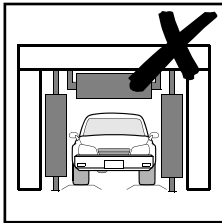

• Pour Support / Warranty Information technique s'il vous plaît appelez: 800-757-7075

1. Nettoyer et sécher le cadre de la portière avant du côté gauche avant la configuration. Baisser la fenêtre et faire l'essai de la bande d'étanchéité mince sur le cadre de la portière de devant. À l'aide d'une règle, aligner le bord arrière de la bande d'étanchéité mince 90mm (3 55/64) devant le bord arrière du cadre de la portière. Aligner le haut de la bande d'étanchéité mince 30 mm (1 3/16) du haut du cadre de la portière. Marquer les zones de fixation au ruban.

2. Bien nettoyer les zones de fixation au ruban sur le cadre de la portière avec le tampon de préparation à l'alcool fourni. Sécher les zones avec un chiffon propre et sec.

**IMPORTANT : LE CADRE DE LA PORTIÈRE DOIT ÊTRE NETTOYÉ AVANT L'INSTALLATION DE LA PIÈCE. LE RUBAN N'ADHÉRERA PAS AUSSI BIEN AU CADRE DE LA PORTE SI LES ZONES NE SONT PAS NETTOYÉES.**

3. Retirer environ 50 mm (2 po) du revêtement du ruban protecteur de chaque section et plier le revêtement à un angle de 45° vers l'extérieur de la bande d'étanchéité mince.

**IMPORTANT : NE PAS TOUCHER LA SURFACE EXPOSÉE DU RUBAN DE FOND.**

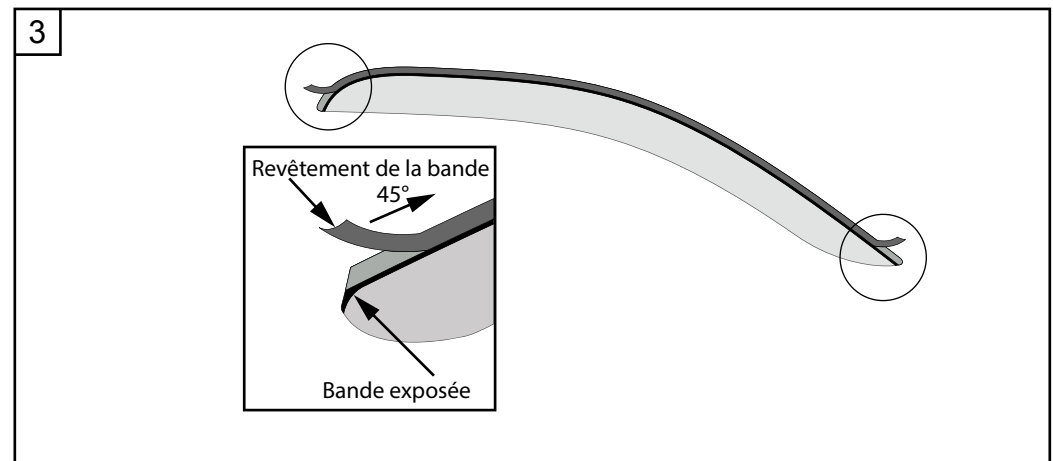
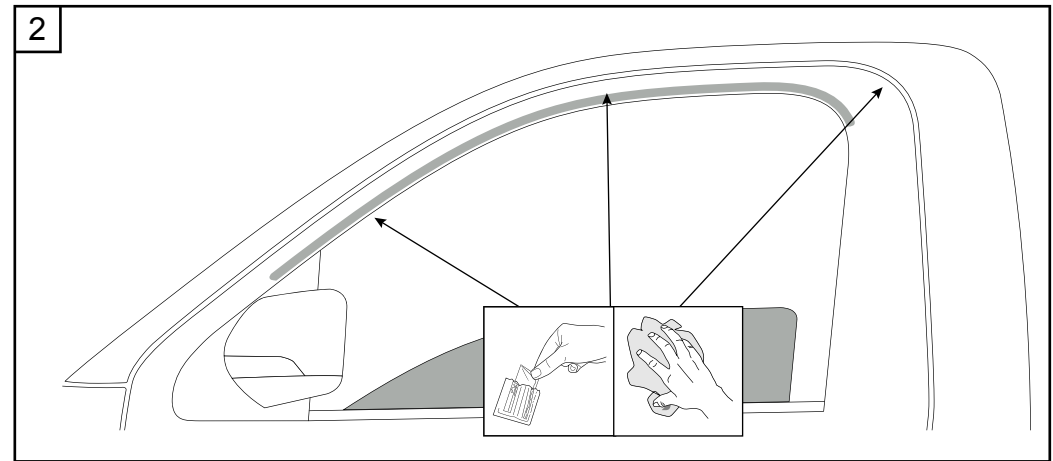
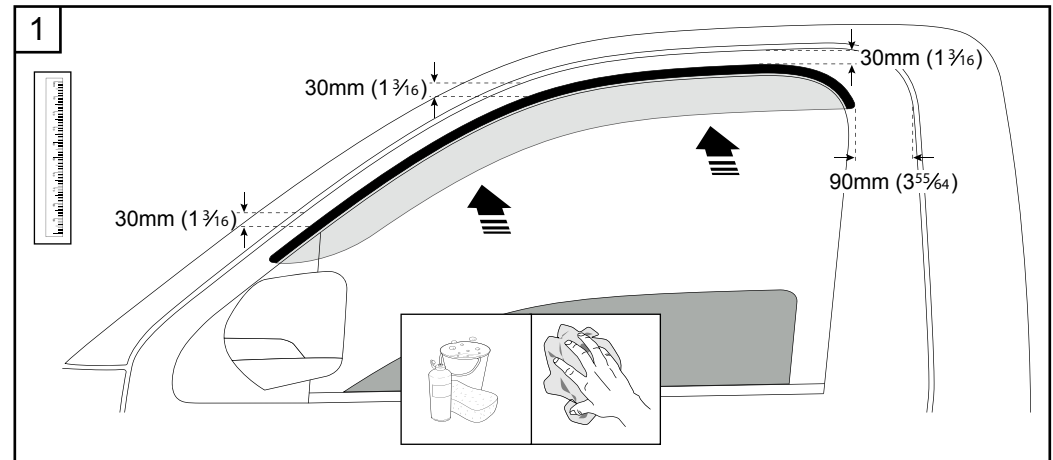

# EGR

## DIRECTIVES D'INSTALLATION

### Outils nécessaires

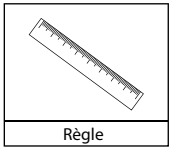

### Remarques sur le nettoyage

- Attendre au moins quatre heures après l'installation avant de conduire.
- Ne pas utiliser un lave-auto automatique.

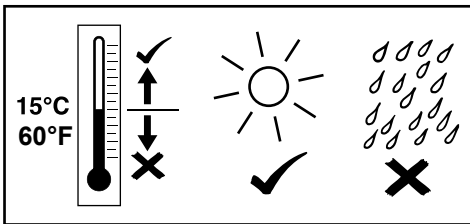
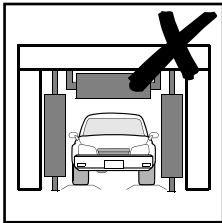

• Pour Support / Warranty Information technique s'il vous plaît appelez: 800-757-7075

- 4• Positionner la bande d'étanchéité mince sur le cadre de la portière. Vérifier la position de la bande d'étanchéité en suivant les directives à l'étape 1. Appliquer ensuite de la pression légère aux zones ayant du ruban.

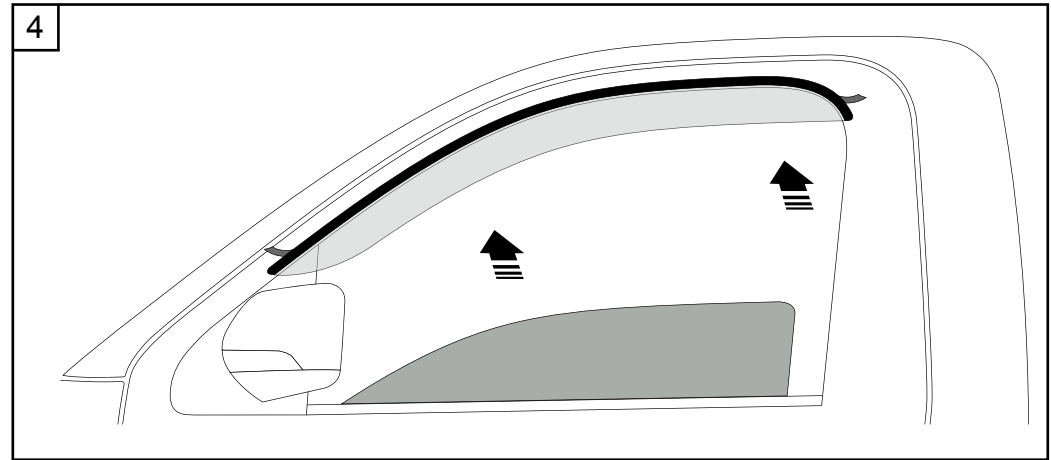

- 5• Peler lentement le reste du revêtement du ruban protecteur en tirant sur les bouts exposés et appliquer une légère pression sur les zones de fixation.

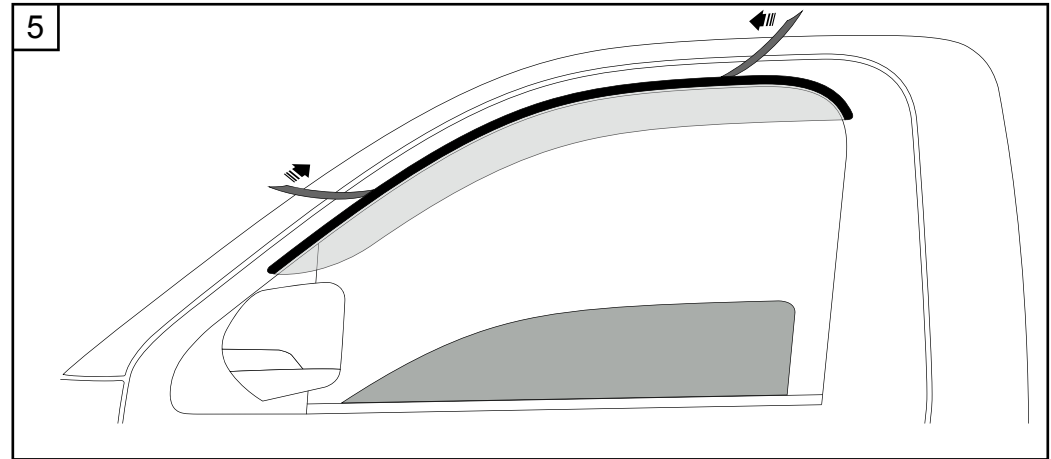

- 6• Frotter fermement les zones de fixation quatre fois avec un chiffon propre et doux afin d'assurer la meilleure adhésion.

Répéter les étapes précédentes pour installer la bande d'étanchéité mince sur le côté droit.

