

<THESE INSTRUCTIONS MUST BE GIVEN TO THE END USER>



B&W Trailer Hitches
 1216 Hawaii Rd / PO Box 186
 Humboldt, KS 66748
 P:800.248.6564
 F:620.869.9031

See Limited Lifetime Warranty at bwtrailerhitches.com/warranty

*Call or Email us for
 Installation Support*
hitches@turnoverball.com
bwtrailerhitches.com

Receiver Hitch Installation Instructions

**MODEL RH660118,
 RH660118BW**

2018 - 2025 Subaru Crosstrek

MAXIMUM TOW RATING (GTW): 4500 LBS
MAXIMUM TONGUE WEIGHT (VTW): 675 LBS

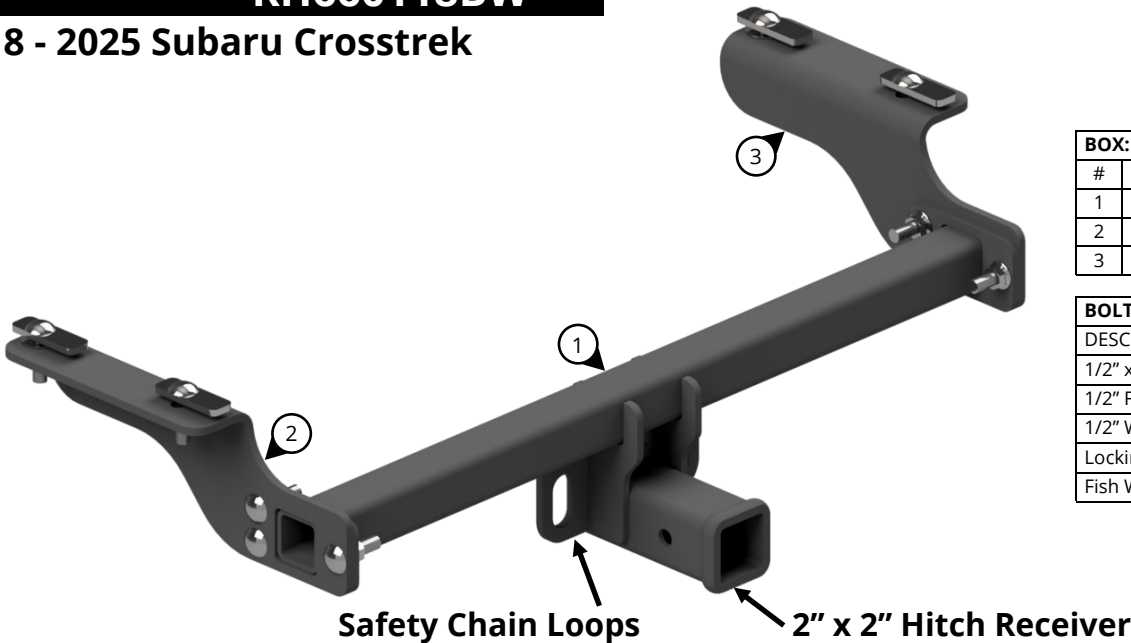

BOX: RH660118		
#	DESCRIPTION	QTY
1	Hitch Frame	1
2	Driver Side Plate	1
3	Passenger Side Plate	1

BOLT BAG: 2110-660118-00		
DESCRIPTION	QTY	
1/2" x 2" Carriage Bolt	10	
1/2" Flange Nut	10	
1/2" Washer	2	
Locking Strap	4	
Fish Wire	4	

IMPORTANT SAFETY NOTICE FOR HITCH INSTALLERS AND CUSTOMERS.

Read all installation and operating instructions along with all labels before installing or using this product.

⚠️ WARNING

Failure to comply with the safety information in these instructions could result in serious injury or death.

- ⚠️ Do not modify this product in any manner. Doing so could alter its integrity and lead to a loss of attachment between the trailer and the tow vehicle.
- ⚠️ Adding components to the chassis of any vehicle can be hazardous. There is potential for unexpected combustion of fuel, electric shock, burns, shifting or falling of unstable vehicle, damage to vehicle, injury from tool usage and many other hazards. This installation must be completed by someone who is aware of the hazards involved. This person must be knowledgeable of proper safety procedures for a vehicle modification of this nature, and for usage of the equipment required to perform the installation.
- ⚠️ Do not exceed tow or tongue rating of coupler, tow or tongue rating of hitch, or tow or weight ratings of tow vehicle or trailer. See vehicle and trailer manufacturer information for ratings. Exceeding these ratings may cause damage to towing components or loss of attachment between the trailer and vehicle.
- ⚠️ This product was designed to fit vehicles in their original, "as manufactured" condition. Compatibility with vehicles having replacement parts, or other modifications is not guaranteed. Inspect vehicle for modifications before installation of this product.
- ⚠️ A visual inspection of the towing components should be performed before each use. Regularly check that all connections are secure, including those that secure the hitch to the vehicle. Check for cracks or damage to the hitch, tow vehicle receiver, trailer coupler and frame. Do not use the hitch if cracks or damage outside of normal wear is found. Using a hitch that has unsecure connections and/or cracks or damage could result in damage to the tow vehicle, trailer, towing components and loss of attachment between the tow vehicle and trailer.
- ⚠️ Without proper knowledge, towing can be a dangerous activity. Understand all the risks involved with towing before proceeding. For information on towing safety, see **"The Trailer Handbook: A Guide to Understanding Trailer and Towing Safety"** from the National Association of Trailer Manufacturers, www.NATM.com and your trailer and tow vehicle manufacturer's owner's manual.
- ⚠️ Always use safety chains while towing. Crossing the safety chains under the tongue of trailer may prevent some damage to the trailer if detachment occurs.

NOTE: Use the parts list on the front page to verify that all parts and hardware are present.

TOOLS REQUIRED

- 3/4" open end wrench
- Torque wrench
- Impact wrench or ratchet
- 3/4" socket
- Safety glasses
- File or die grinder
- Pick tool

PREPARE FRAME HARDWARE



PICK TOOL

1. Under the rear of the vehicle, locate the two chassis channels on either side of the vehicle, above the muffler. Use a pick tool to remove the four indicated hole covers from the chassis channels, see Figure A1.



FIGURE A1: VIEW UNDER THE REAR OF THE VEHICLE



FILE

- OR -



DIE GRINDER

2. The two forward holes will need to be modified with a file, die grinder, or similar tool to allow the head of the 1/2" carriage bolt to pass through the hole. Remove 3/16" of material from either side of the forward holes, as shown in Figure A2.

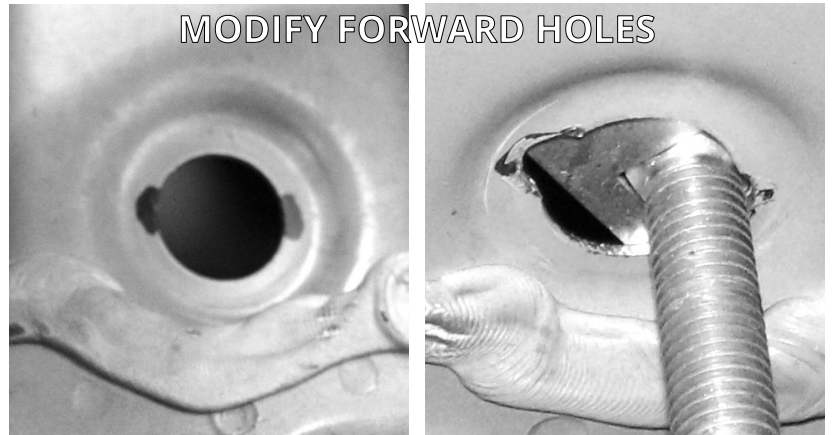

FIGURE A2: VIEW UNDER THE REAR OF THE VEHICLE

PREPARE FRAME HARDWARE CONTINUED

3. Thread a carriage bolt and locking strap onto a fish wire. Pass the non-coiled end of the fish wire into the hole at the rear end of the chassis channel through the channel and into the larger forward hole, as shown in Figure A3. Insert the locking strap and carriage bolt into the channel through the large hole. Pull on the fish wire to bring the carriage bolt through the rear hole.
4. Thread another carriage bolt and locking strap onto a fish wire. In the larger forward hole, pass the carriage bolt and locking strap with fish wire into the channel, as shown in Figure A3. Pull the carriage bolt back down, through the locking strap, inside the larger hole.

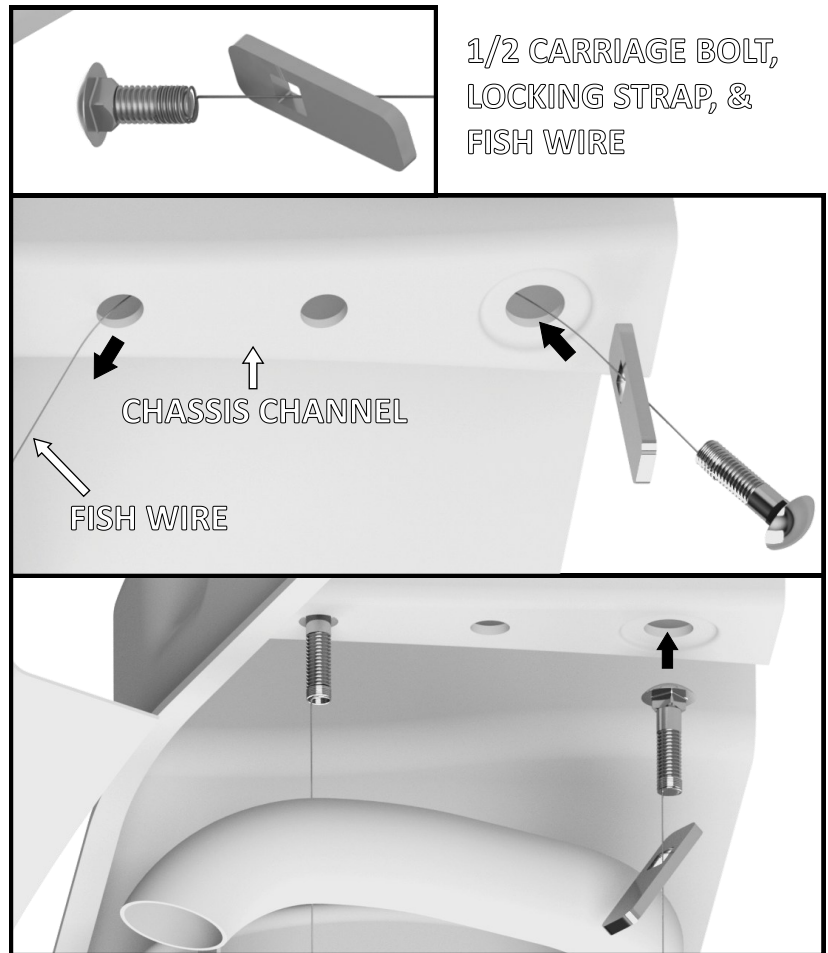

FIGURE A3: VIEW OF PASSENGER SIDE CHASSIS CHANNEL

INSTALL HITCH FRAME



3/4"
SOCKET

5. Attach each side plate to the vehicle using the two 1/2 x 2" carriage bolts that are positioned inside the chassis channels. A 1/2" flat washer should be placed between the side plate and the chassis channel around the forward bolt. Pass each side plate up over the bolts and secure them with two 1/2" flange nuts, as shown in Figure B1. Loosely attach bolts at this time.

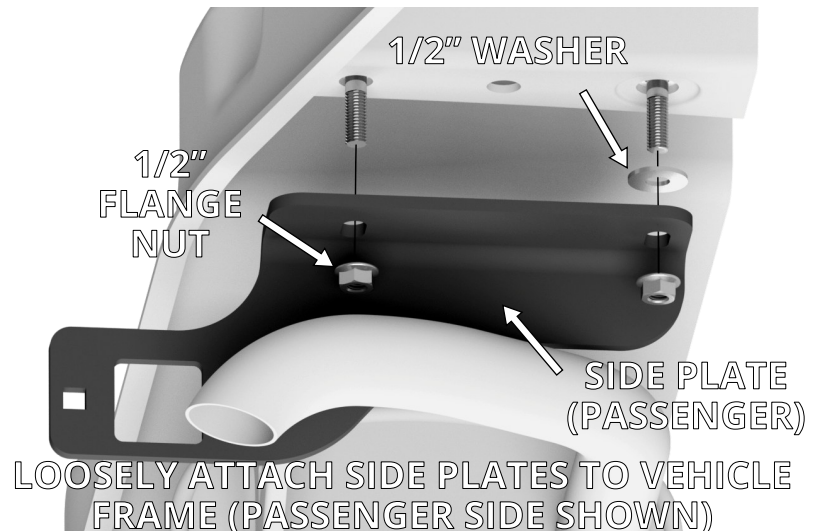

FIGURE B1: VIEW OF PASSENGER SIDE PLATE INSTALL

INSTALL HITCH FRAME CONTINUED



3/4"
SOCKET



TORQUE
WRENCH

6. Raise the hitch frame between the side plates, as shown in Figure B2. Use six 1/2" x 2" carriage bolts and six 1/2" flange nuts to secure the hitch frame to the side plates.
7. Center the hitch frame so the receiver is in the middle of the vehicle.

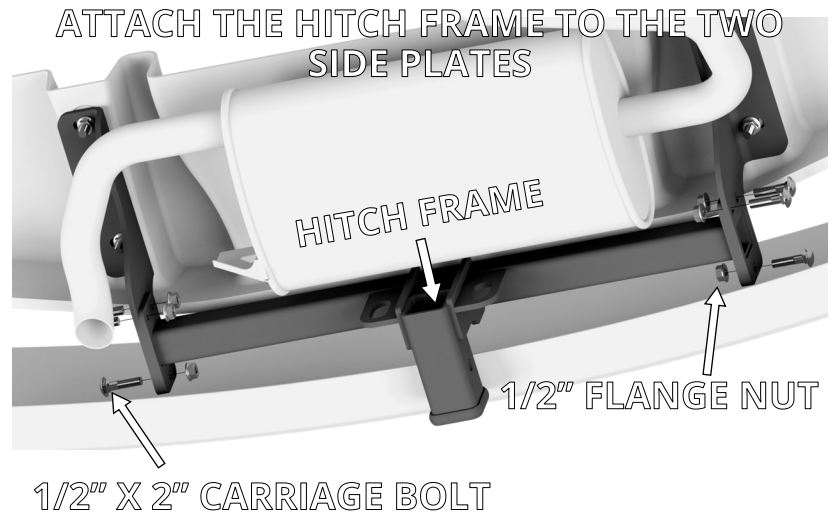

FIGURE B2: VIEW UNDER THE REAR OF THE VEHICLE



PICK TOOL

8. Two plastic tabs holding the fascia may need to be temporarily relocated to make room to tighten the 1/2" carriage bolts. Use a pick tool to remove the plastic rivets as shown in Figure B3.
9. Tighten each bolted connection, then torque all ten flange nuts to 100 ft.-lbs.
10. If they were removed, replace the plastic rivets removed in Step 8.

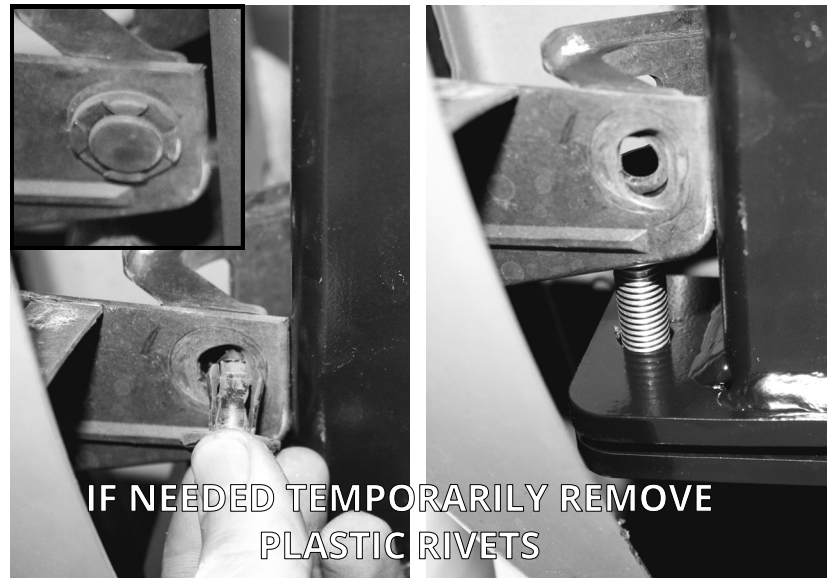

FIGURE B3: VIEW UNDER THE REAR OF THE VEHICLE