

Guardian Comfort Full Bed Liner

GUARDIAN COMFORT FULL BED LINER INSTALLATION INSTRUCTIONS NISSAN FRONTIER

U.S. PATENT # 5007670,5806909 MADE IN U.S.A.

WARNING: IMPROPER INSTALLATION WILL RESULT IN MAT FLYING OUT OF THE TRUCK!

FOLLOW INSTRUCTIONS EXACTLY!

APPROXIMATE INITIAL INSTALLATION TIME LESS THAN 1 HOUR

1. Read all instructions before installing.
2. **NOTE:** TRUCK BED SURFACE TEMPERATURE SHOULD BE 68° FOR HIGHER IN ORDER FOR THE HOOK FASTENERS TO ACHIEVE MAXIMUM ADHESION. ALSO, NEVER CONTAMINATE THE ADHESIVE BY TOUCHING IT WITH YOUR FINGERS.
3. Remove Premium Full Bed Liner floor, siderugs, filler strips and installation kit from box.
4. Attach five (5), 1 7/8" wide and two (2), 2 1/4" wide rib filler strips to locations on foam side of Bed.Rug floor with double sided tape included with kit. Filler strip locations are scored into backside of part. Discard two (2), 1 7/8" strips if the truck is equipped with the Utili-Track Bed System.

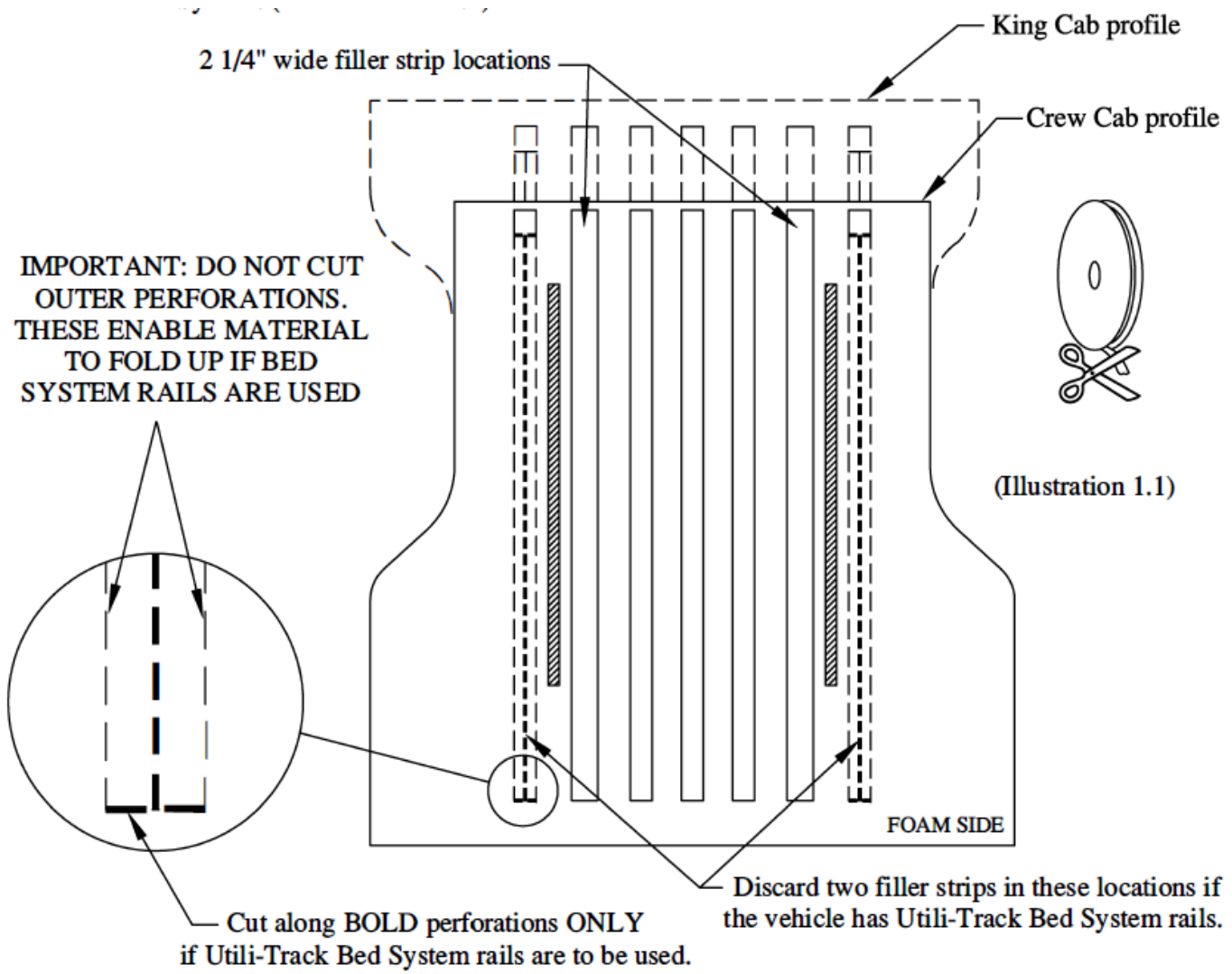

Guardian Comfort Full Bed Liner

5. Zip Premium Full Bed Liner floor and siderugs together to form the one-piece soft bed liner.
6. A continuous loop fastener is sewn around the liner. The bulkhead and tailgate have two continuous strips of loop fastener sewn along the top and bottom. The very aggressive hook fasteners have a self-adhesive backing to stick to the bed of the truck.
7. Attach hook fasteners to the loop per illustration 1.2. For siderugs, be sure to place the 2" long hook fasteners at the locator marks which are molded into the foam

HOOK FASTENER LOCATIONS/UTILI-TRACK INSTRUCTIONS

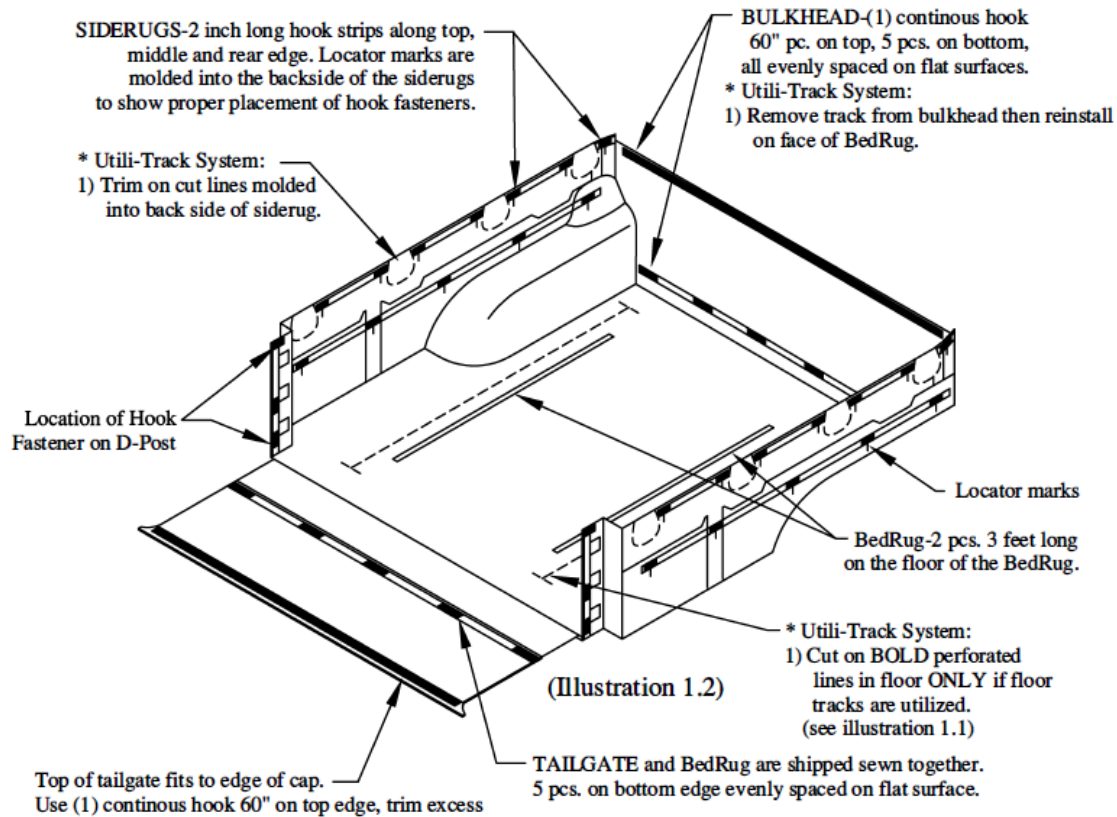

8. Lay the BedRug soft bed.liner in the bed of the truck to determine the exact location and fit. **IMPORTANT:** Never cut or put slits through any seams or sewn areas of the BedRug. This will cause the seam to come completely apart.
9. Roll one side of the BedRug floor up exposing the area where the 3' strip of hook fastener is to be adhered.
10. Using a clean lint-free cloth, clean this area thoroughly using **NON-PETROLEUM** based solvent. Then with a separate cloth, clean the same area again with alcohol. If the cloths become visually soiled, replace them with clean ones.
11. Lay the BedRug down, then **FIRMLY** rub the fastener(s) down **VERY AGGRESSIVELY** to assure full engagement of the fastener(s) and the adhesive.
12. Repeat steps 10 and 11 for the opposite side of the BedRug floor.
13. Repeat steps 10 and 11 on the bulkhead.
14. Repeat steps 10 and 11 on the siderugs.
15. Repeat steps 10 and 11 on the tailgate.

Guardian Comfort Full Bed Liner

CLEANING INFORMATION

The mildew resistant Bed Mat foam will not absorb liquids. The engineered polypropylene fiber top surface resists stains and deterioration from most acids, chemicals, gas and oils, etc. Therefore, by following the cleaning instructions below, your Bed Mat will remain serviceable for as long as you own your truck.

Cleaning your Bed Mat is easy:

1. A vacuum, broom, brush or compressed air can be used to remove dirt, grime, sand, mulch, etc. Due to the fact that water will not harm the Bed Mat, pressure washing is also an effective way to clean a soiled Bed Mat.
2. Although most acids will not harm the Bed Mat, baking soda should be applied immediately to neutralize the acid to ensure the safety of the paint on the truck.
3. To clean tougher jobs such as gasoline, oil, chemicals, acid spills or leaks from your Bed Mat use detergent soap with degreaser and water, then rinse thoroughly. This detergent soap is used in most car wash locations with pressure washing equipment. The Bed Mat polypropylene closed-cell foam will not absorb water and the polypropylene fiber dries in minutes.

Retain this cleaning information with your vehicle owner's manual for future reference.

Congratulations!

We take the utmost pride in our products and want you to enjoy years of satisfaction from your investment. We have made every effort to ensure that your product is top quality in terms of fit, durability, finish and ease of installation.

www.huskyliners.com

Phone: 800-344-8759

Email: customerservice@huskyliners.com



GUARANTEED...FOR LIFE.