



BX2632

2011-15 Ford Explorer (Includes ACC & EcoBoost) Installation Instructions

Attachment Tab Height: 18-1/2"

Attachment Tab Width: 20"

Serial Number

Please read BOTH these Installation Instructions and the General Information sheet prior to installing or operating this equipment.

1. Blue Ox® towing products and accessories are intended to be installed by Blue Ox® Dealers who are familiar with our products and have the equipment and knowledge necessary to do "fit work". If needed, Blue Ox® Dealers can be found at www.blueox.com or by contacting our Technical Service Department at (402) 385-3051.
2. Many Blue Ox® baseplates are designed to use existing holes and hardware to mount the baseplate to the towed vehicle. Even though bolts are there, do not assume they are adequate for baseplate mounting. Always use the hardware supplied in the hardware kit and existing hardware as specified in the installation instructions.



If the front of your vehicle looks different than this, please contact us at (402)385-3051.

Reference your vehicle owner's manual for manufacturer's towing specifications.

Bolt Torque Specifications

Torque in Foot-Pounds for Inch Bolts

Bolt Size	Grade 5	Grade 8
1/4"	10	14
5/16"	19	29
3/8"	33	47
7/16"	54	78
1/2"	78	119
5/8"	154	230
3/4"	257	380

Bolt Torque Specifications

Torque in Foot-Pounds for Metric Bolts

Bolt Size	Grade 8.8	Grade 10.9
6MM	6	8
8MM	16	22
10MM	31	40
12MM	54	70
14MM	89	117
16MM	161	230
18MM	222	318

WARNING

Failure to read and follow these instructions could result in separation of the towed vehicle from the tow bar, causing property damage, loss of towed vehicle, personal injury or death.

BX2632
2011-15 Ford Explorer (Includes ACC & EcoBoost)
Installation Instructions

Instruction Notes: The fascia, ACC sensor, bumper and windshield washer fluid reservoir are removed and reinstalled for the baseplate installation. Some drilling and trimming is required.

Place all components that are removed on a flat, sturdy surface. All items will be reinstalled unless otherwise noted after the baseplate is installed.

The dimensional variations between otherwise identical vehicles can be considerable. While the baseplate was designed for easy installation, it may be necessary to tailor the baseplate slightly to compensate for vehicle manufacturer's tolerances.

The BX8848 4-Diode Wiring Kit is recommended for this vehicle.

NOTICE

- Handling of some cosmetic parts when installing this product may require the use of protective covers, rags, specialty tools, etc. to prevent damage.
- When using power drills be aware of the dangers of torque and drill bit length.
- When using a reciprocating saw be aware of objects behind the cutting surface.
- Use a good quality paint to spray cut edges of frame to prevent rusting.
- Be sure that **ALL** electrical connections are plugged in and accessories are functioning properly before reinstalling the fascia.
- The baseplate is computer tested to your vehicle's GVWR, exceeding this weight will void the manufacturer's warranty.
- Be sure to use a sufficient amount of Loctite® Red on all bolt threads before tightening. Tighten all bolts according to the torque chart provided.
- Dealer or installer be certain the user receives these instruction sheets.
- If the baseplate is in an accident, it must be replaced. **DO NOT** use it again! An accident can cause unseen damage and using it again could result in more damage or serious injury. **DO NOT** use the baseplate if it is damaged or missing parts.

BX2632
2011-15 Ford Explorer (Includes ACC & EcoBoost)
Installation Instructions

Tools Required

- 8MM Socket
- Hammer
- 13/32" Drill Bit
- 11MM Socket
- 13MM Socket
- 25/32" Drill Bit
- LOCTITE Red
- 1 1/8" Socket
- Reciprocating Saw
- Flat Screwdriver
- Utility Knife
- 5.5MM Socket
- 10MM Socket
- Torque Wrench
- 17/32" Drill Bit
- Tape Measure
- 3/4" Socket
- Drill
- Large Vise Grip
- Phillips Screwdriver

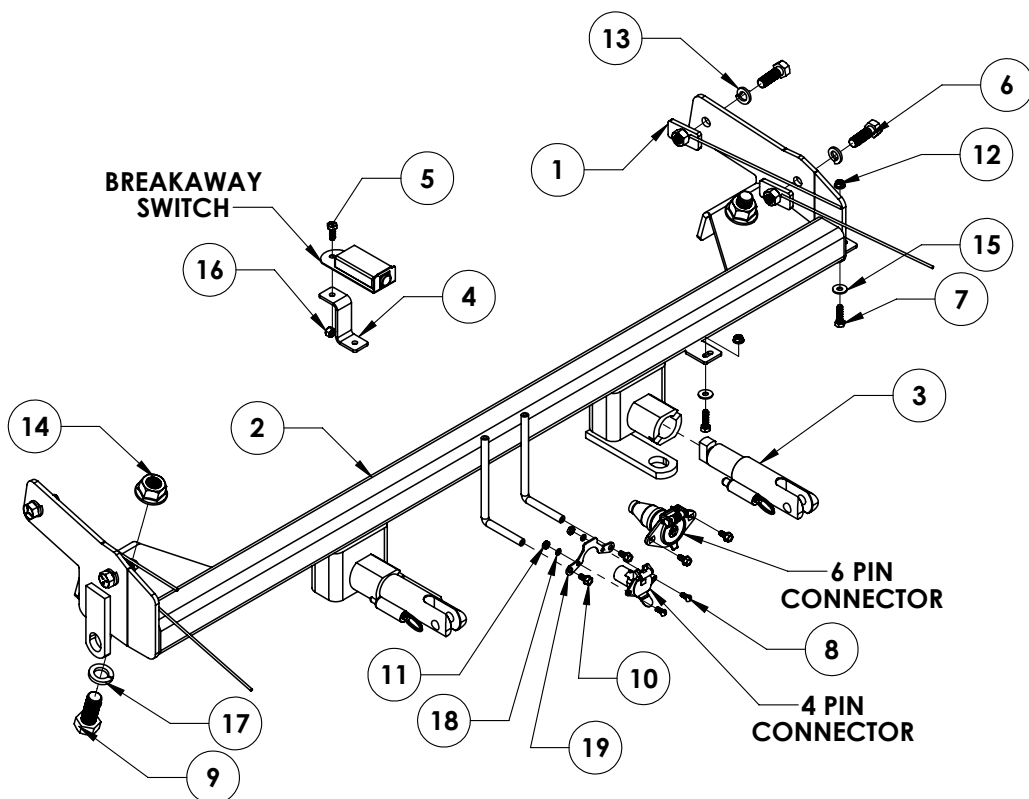

Item No.	Part No.	Description	Qty.
1.....	61-4604	1/2" Nut Plate w/ 10" Wire	4
2.....	61-6867	BX2632 Baseplate.....	1
3.....	62-3468	Attachment Tab Assembly with Hole	2
4.....	102-7056	Breakaway Bracket	1
5.....	201-0050	1/4"-20 x 3/4" Hex Head Bolt, Grade 5, ZP	1
6.....	201-0051	1/2"-13 x 1-1/2" Hex Head Bolt, Grade 5, ZP	4
7.....	201-0071	1/4"-20 x 1" Hex Head Bolt, Grade 5, ZP	2
8.....	201-0192	#10-32 1/2" Round Slotted Head Screw.....	2
9.....	201-0514	3/4"-10 x 1-3/4" Hex Head Bolt, Grade 5, ZP	2
10.....	201-0553	1/4"-20 x 1/2" Hex Head WSHD Type F TCS, ZP	4
11.....	202-0047	#10-32 Hex Nut	2
12.....	202-0069	1/4"-20 Hex Flange Whiz Lock Nut, ZP	2
13.....	203-0012	1/2" Lock Washer, ZP	4
14.....	202-0074	3/4"-10 Hex Flange Whiz Lock Nut, ZP	2
15.....	203-0001	1/4" Flat Washer, ZP.....	2
16.....	202-0102	1/4"-20 Hex Nylon Nut, ZP	1
17.....	203-0014	3/4" Lock Washer, ZP	2
18.....	203-0054	#10 Lock Washer, ZP	2
19.....	299-0685	Electrical Bracket, ZP	1
20.....	226-0049(not shown)	Class IV Safety Cables.....	2
21.....	229-0512(not shown)	1/2" Quicklink, ZP	2
22.....	290-0437(not shown)	Black Cap Plug Receiver.....	2

Important:

Use only genuine factory replacement parts on your baseplate. Do **NOT** substitute homemade or non-typical parts. If a bolt is lost or in need of replacement, for your safety and the preservation of your baseplate, be sure to use a replacement bolt of the same grade (In most cases it will be Grade 5, please reference the parts list above). Replacement parts may be ordered through your nearest Blue Ox® Dealer or Distributor. Failing to follow and/or altering these installation instructions in either installation or required equipment will void the manufacturer's warranty. Towing behind a non-motorized vehicle will void the warranty.

BX2632
2011-15 Ford Explorer (Includes ACC & EcoBoost)
Installation Instructions

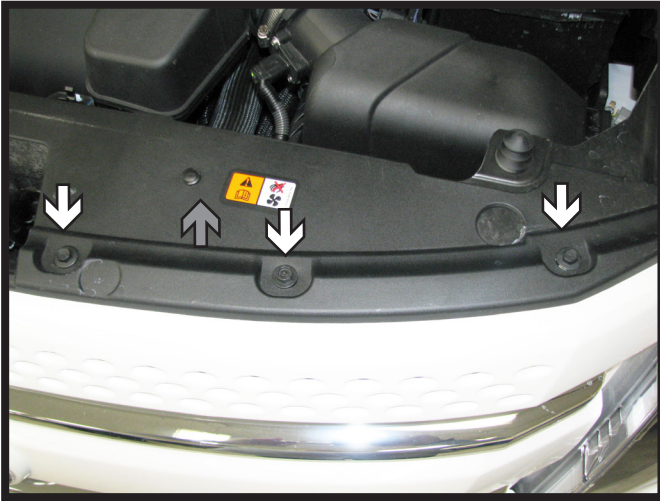

1. Using a 10MM socket, remove three bolts (white arrows) from the black plastic cover on the top side of the fascia. Also remove one push pin (gray arrow). Do this to both sides of the vehicle. On the passenger side, there are four bolts to remove. Set bolts and pushpins aside to be reinstalled later.

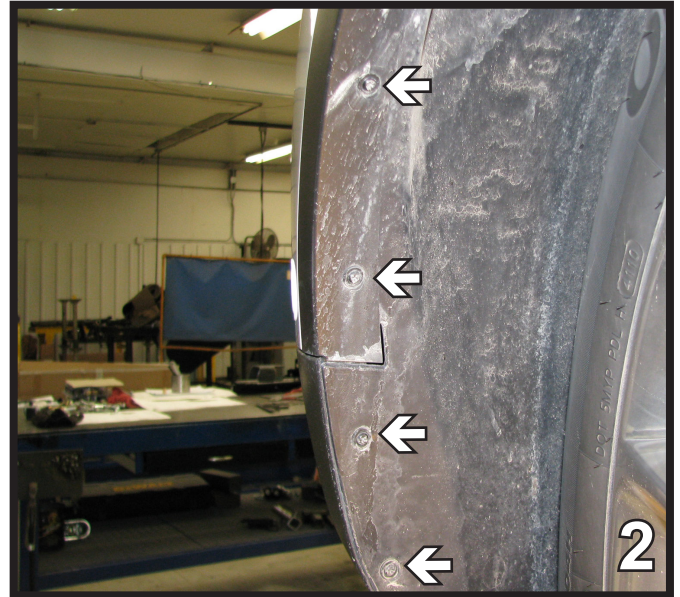

2. In front of the tire, using a Phillips screw driver or 5.5MM socket, remove the four pushpins. Do this to both sides of the vehicle. Set pushpins aside to be reinstalled later.

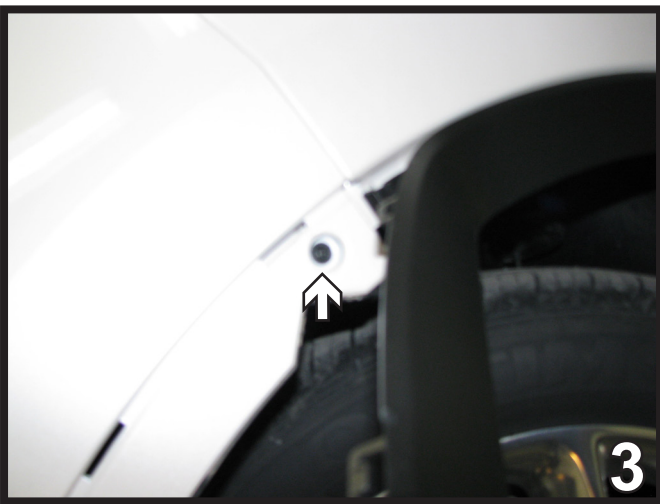

3. Just forward of the front tire, on the fascia's corner, pry loose the protective rubber edging, remove one Phillips screw with a Phillips screwdriver. Do this on both sides of the vehicle. Set the screws aside to be reinstalled later.



4. Just forward of the front tire pull the cover back, remove one screw with a Phillips screwdriver or 5.5MM socket. Do this to both sides of the vehicle. Set screws aside to re-install later.

BX2632
2011-15 Ford Explorer (Includes ACC & EcoBoost)
Installation Instructions

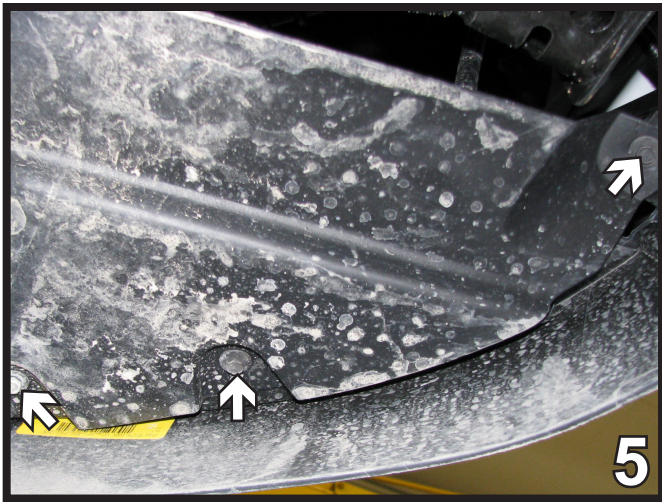

5. Using an 8MM socket remove three bolts under the fascia corner, in front of the tire. Do this to both sides of the vehicle. Set bolts aside to be reinstalled later.



6. Using an 8MM socket remove the three metric bolts from the front of the fascia, located under the vehicle going across. There is one on each side and one in the middle, two are shown. Pull fascia corners down, then forward to release. Disconnect electrical connections. Set the fascia and the metric bolts aside to be reinstalled later.

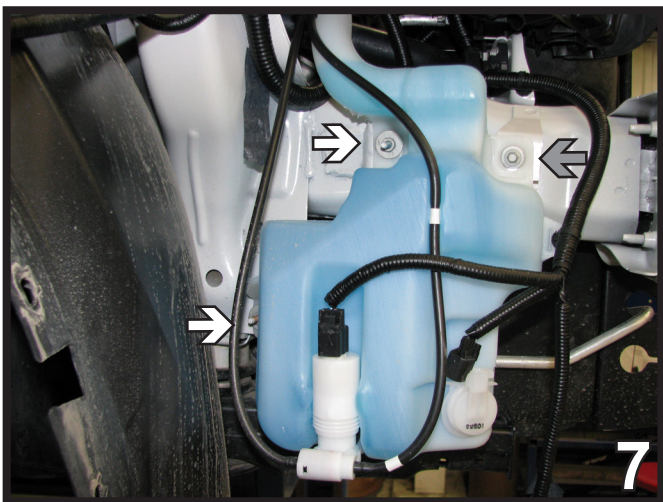

7. Using an 8MM socket (gray arrow), remove the bolt on the top. Using an 11MM socket, remove the two bolts on the sides (white arrows). Disconnect the two hoses and plug them. Set the bolts and the reservoir aside to be reinstalled later.

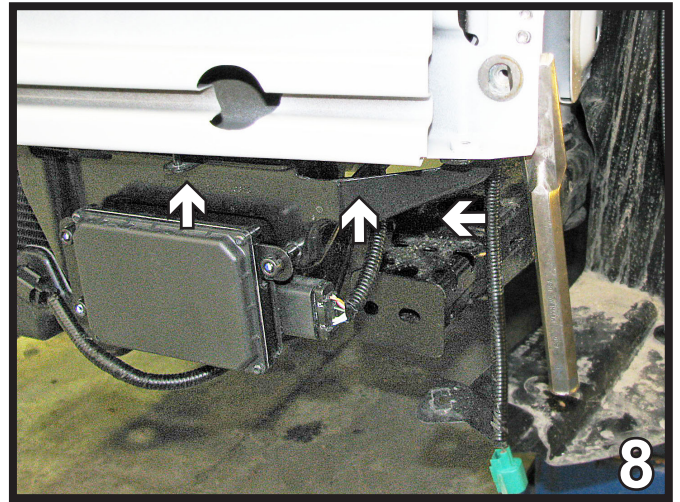

8. On driver's side only, using an 8MM socket, remove the two bolts from the bracket holding the speed control underneath the bumper. Set the bolts aside to be reinstalled later and move the speed control to the side out of the way.

BX2632
2011-15 Ford Explorer (Includes ACC & EcoBoost)
Installation Instructions

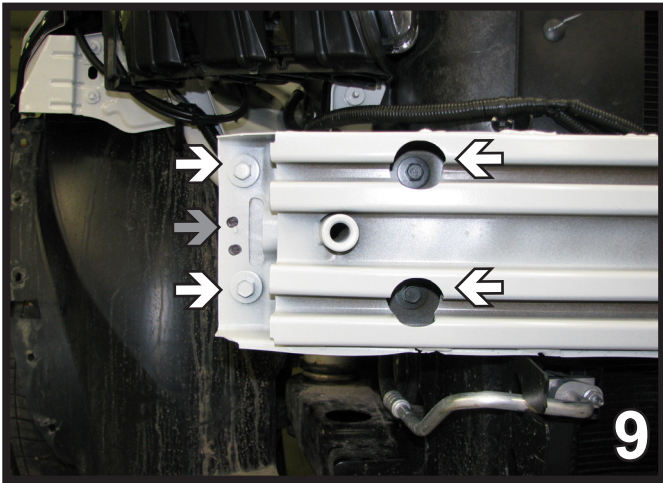

9. On the passenger side using a 13/32" drill bit, drill out the two spot welds on the metal bumper (gray arrow). Using a 13 MM socket, remove the four bolts (white arrows).

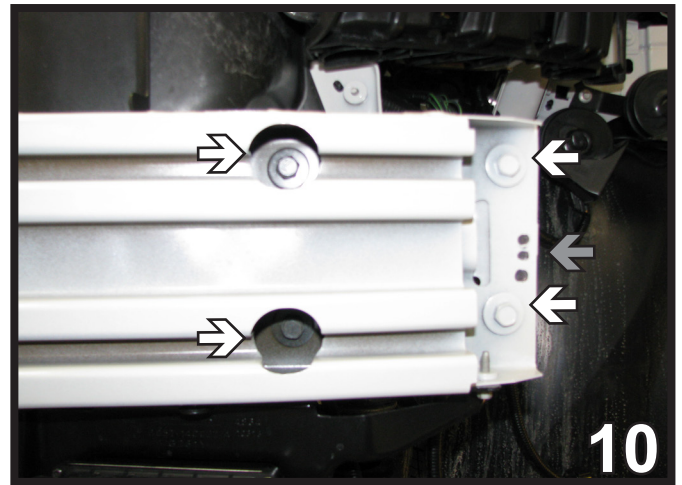

10. On the driver side using a 13/32" drill bit, drill out the three spot welds on the metal bumper (gray arrow). Using a 13MM socket, remove the four bolts (white arrows). Bolts and bumper will not be reinstalled.

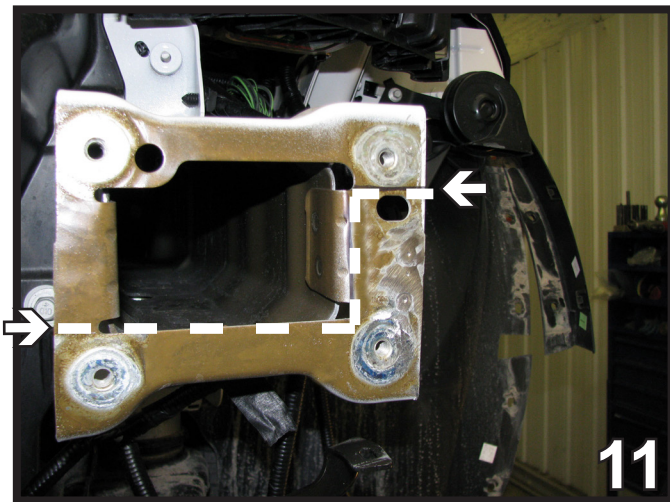

11. On the top outside of each bumper end, cut across at the bottom of the groove, straight down, on the outside of the frame rail, across the bottom flush with the front of the frame and remove the whole piece. Do this on both sides.

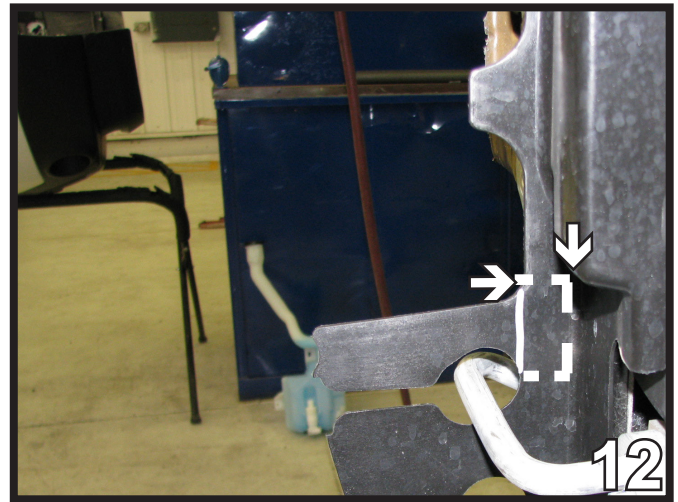

12. ACC Models: On the passenger side, remove the top part of the plastic flap by cutting with a utility knife straight down above the hose. Notch out a little farther by cutting in as far as you can.

BX2632
2011-15 Ford Explorer (Includes ACC & EcoBoost)
Installation Instructions

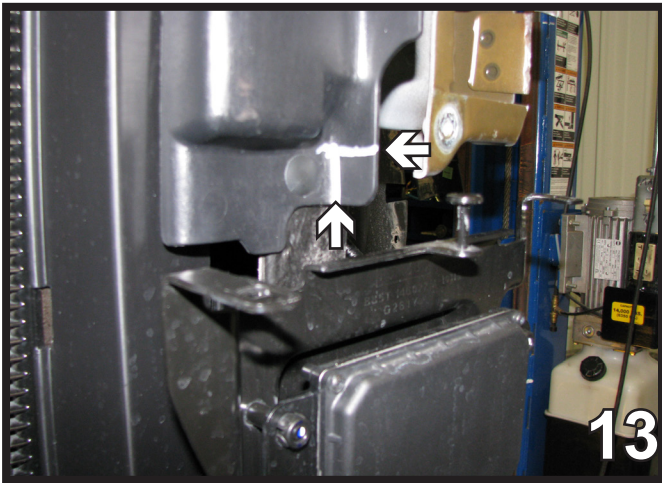

13. ACC Models: On the driver's side, cut a little square notch out of the corner of the plastic air dam with a utility knife.

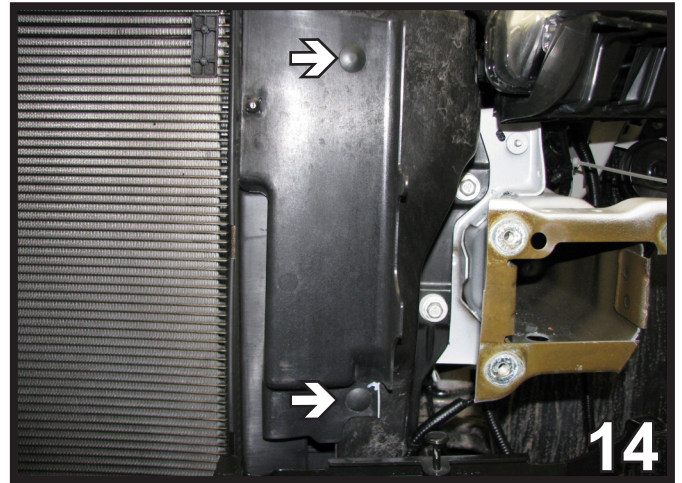

14. Non-ACC models: Remove the two push pins holding the plastic cover. Do this on both sides. Set the covers aside they will not be reinstalled.

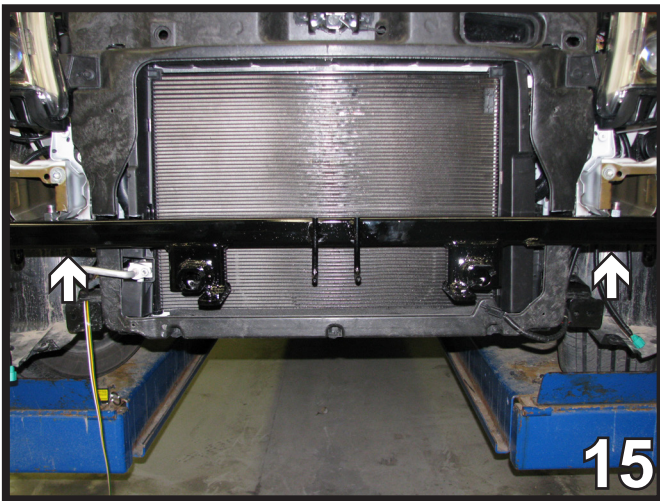

15. Tip the baseplate up, lower the driver's side down, slide the baseplate in, lift up and clamp. Start the 3/4-10 bolt in the frame bottom existing hole. Do this on both sides.

NOTE: Some vehicles may require existing hole to be reamed or drilled, with a 25/32" drill bit.

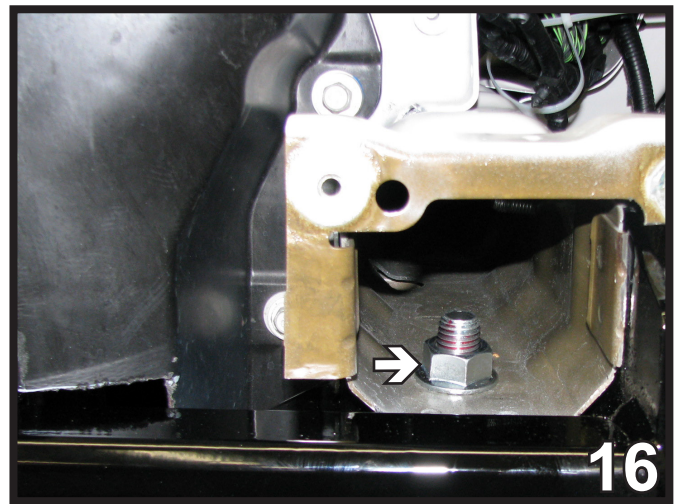

16. Install 3/4-10 x 1 3/4" bolts with 3/4" lock washers and 3/4-10 whiz nuts. Be sure to use loctite on all bolts. Do this on both sides.

BX2632
2011-15 Ford Explorer (Includes ACC & EcoBoost)
Installation Instructions

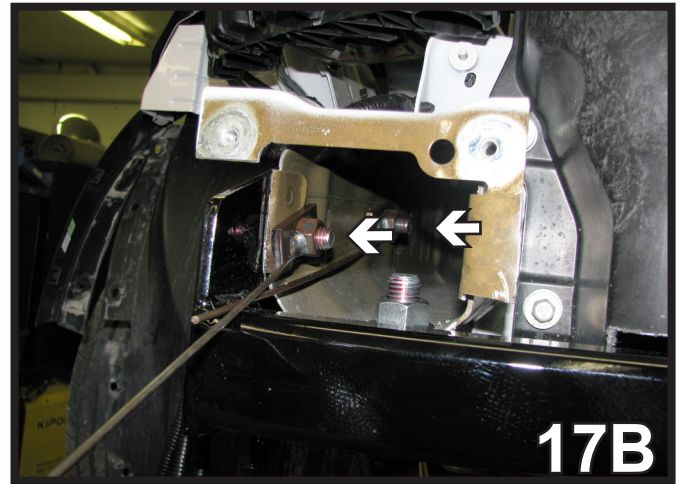
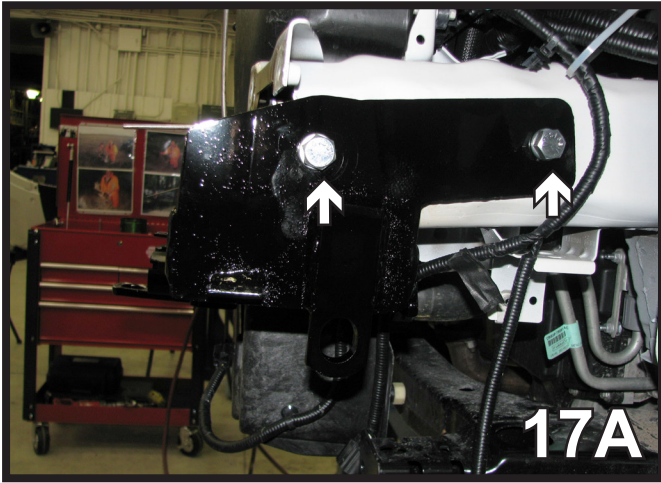

- 17A. Using the baseplate as a template, drill the two holes on the side with 17/32" drill bit. Insert two 1/2-13 x 1 1/2" bolts with 1/2" lock washers. Be sure to use loctite on all bolts.
- 17B. Tighten with two 1/2-13 nut plates aligned inside the frame rail. Do this on both sides.

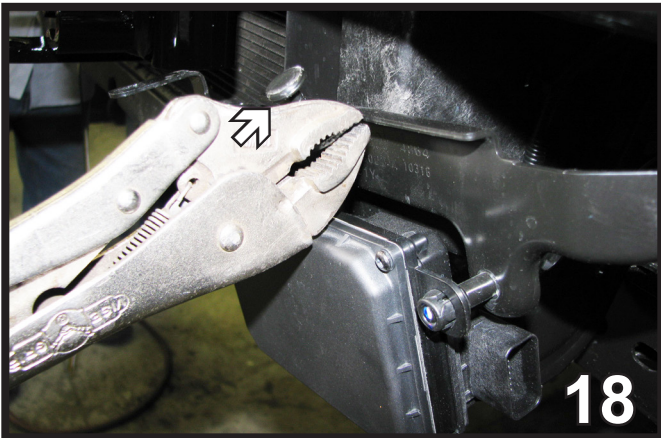

18. If the vehicle has adaptive cruise control, reattach it on the driver's side. Using a vise grip bend the pin downward out of the way.

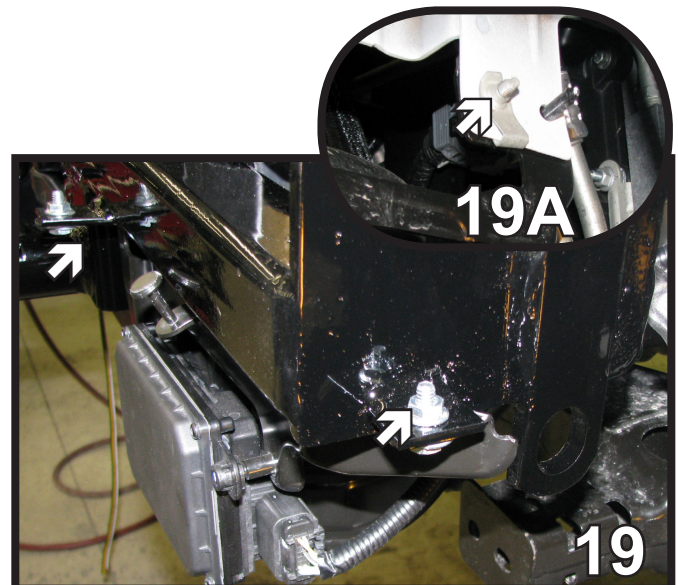

19. Slide the adaptive cruise control module to its original position, flush with the baseplate and in a perfectly vertical position. Reattach adaptive cruise control to the baseplate onto the tabs provided using 1/4-20 x 1" hex bolts and 1/4-20 whiz nuts (white arrows). If needed, 1/4" flat washers can be added to level the adaptive cruise control module. Using existing bolt attach final bolt behind baseplate to finish securing the module (19A).

BX2632
2011-15 Ford Explorer (Includes ACC & EcoBoost)
Installation Instructions

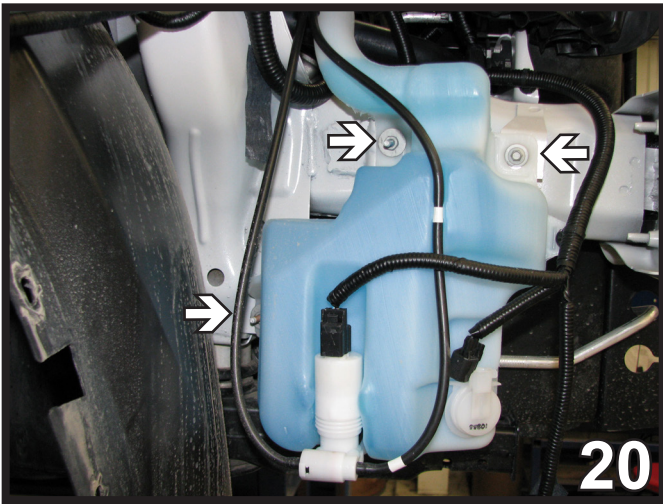

20. Reconnect the windshield washer reservoir, using all the existing hardware which was previously removed. Reconnect the two hoses and the electrical lines.

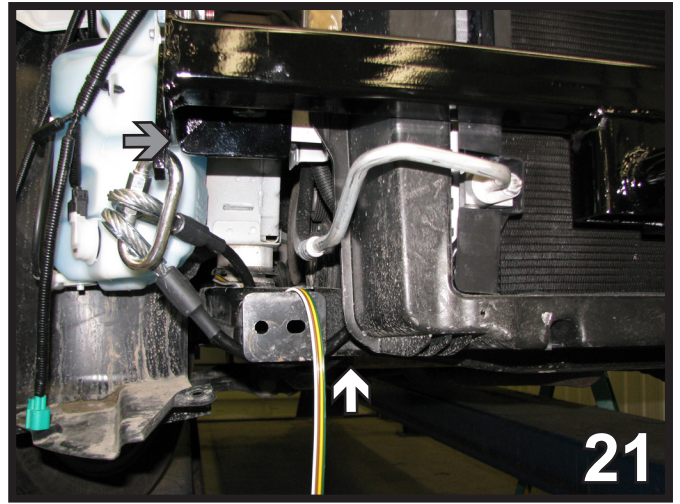

21. Attach the permanent baseplate safety cables to the provided convenience link on the baseplate (gray arrow). The photo above shows the recommended installation of the cables to frame of vehicle (white arrow). Additional options may interfere with suggested mounting; in this case secure the cables to a solid piece of the frame as described in the instructions included with the permanent baseplate safety cables. Be sure the safety cables do not rub against any hoses or moving parts. Do this to both sides of the vehicle.

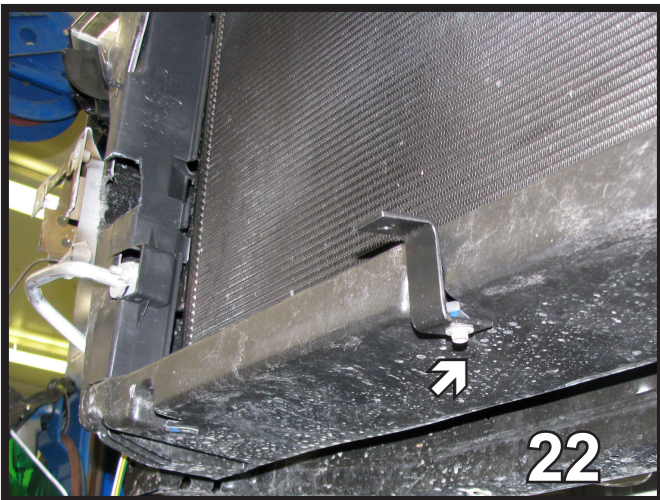

22. **OPTIONAL:** Attach the bracket underneath of the shroud with the self drilling screw at the desired location. Attach the breakaway to the bracket with 1/4-20 x 3/4" hex bolt and 1/4-20 hex nut.



23. On the backside of the fascia by the fog light, cut the white tab off. Do this on both ends of the fascia.

BX2632
2011-15 Ford Explorer (Includes ACC & EcoBoost)
Installation Instructions



24. Hold the fascia as close to its original position, mark and trim the fascia around the convenience links and attachment tabs. Reinstall the fascia.

CUSTOMER SERVICE COMMITMENT

Blue Ox® is committed to providing you with exceptional customer care throughout your lifetime with our products. Our team is here to assist you with any questions you may have regarding the performance of your product. Simply call (402) 385-3051 and you can speak with our technical service team.

Additionally, please visit our website to see which rallies our Destination America team will be attending. For a nominal fee, our service technician will service your towing system to ensure it's in proper working condition. Also, as a commitment to our customers, should you visit our factory, you can stay at our full service Blue Ox® campground at no charge along with enjoying a factory tour.

Again, thank you for being our customer and for the confidence you have shown in the performance of our products. It is because of customers like you we enjoy the success we have today.

© 2016 Blue Ox
One Mill Road, Industrial Park
Pender, Nebraska 68047
Phone: (402) 385-3051
Fax: (402) 385-3360
www.blueox.com

General Information

1. Ensure that your product(s) are registered online at www.blueox.com. It is crucial to register your product(s) so that you may be alerted of product offerings, updates, upgrades, maintenance and safety bulletins, and/or recalls.
2. **It is the owner's responsibility to inspect all towing equipment for cracked welds, missing or worn parts and loose bolts before each towing trip.** Be sure to use Loctite® Red on all bolts and tighten to the recommended specifications.
3. **It is the owner's responsibility to hook up all towing equipment per manufacturer's instructions/recommendations.**
4. Remove the attachment tabs when not in use (if applicable).

Notice To Baseplate Installer

1. **It is YOUR responsibility to watch for:**

- Oil cooler and air conditioner lines
- Electrical wires and hoses
- Missing parts or attaching points on the frame

** If the baseplate is improperly installed and is against a wire or hose, it could cause fluid leaks or electrical shorts some time after the actual baseplate installation.

Permanent Baseplate Safety Cable Installation

Permanent baseplate safety cables are strongly recommended when towing a vehicle with a tow bar. The principle function of the permanent baseplate safety cables is to prevent the towed vehicle from breaking loose in the event the connection between the frame of the towed vehicle and the baseplate fails or becomes disconnected. The cables must be connected from the baseplate to the frame rail or cross member of the vehicle's frame. The illustrations below show the possible arrangements recommended by Blue Ox®. Each permanent baseplate safety cable must have an adequate weight rating for the towing system. The weight rating of the two (2) cables together will not qualify.

Do not mount the permanent baseplate safety cables against wires, hoses or brake lines.

These permanent baseplate safety cables should remain installed as long as the baseplate is installed on the vehicle. Permanent baseplate safety cables are to be used in conjunction with, and NOT a replacement for legally required safety cables attaching the towed vehicle to the towing vehicle.

Option #1

(Baseplates with Convenience Link Tabs)

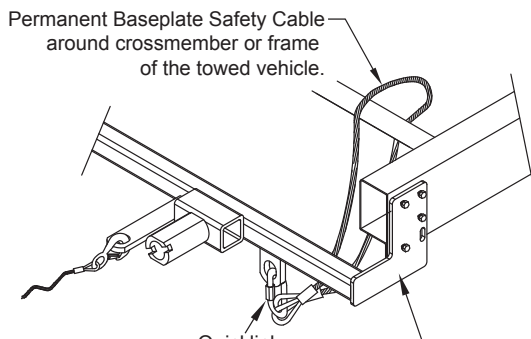

Option #2

(Baseplates with out Convenience Link Tabs)

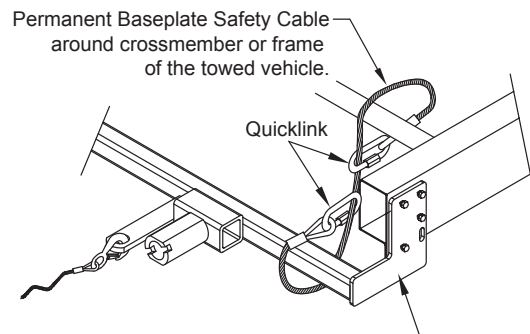

BLUE OX ORIGINAL PURCHASERS THREE YEAR LIMITED WARRANTY

Automatic Equipment Manufacturing Company ("Automatic") warrants to the original (first) retail purchaser that this product, manufactured by Automatic, shall be free from defect in material and workmanship under normal use and service for a period of three years from the date of delivery.

During said three-year period, Automatic will repair or replace any parts that have been returned by the original purchaser, to the factory, transportation prepaid, and in Automatic's sole and absolute opinion found to be defective.

Limitations on Warranty Coverage:

Coverage under this warranty will be valid only if the customer warranty card is returned by the original purchaser within 30 days of purchase.

Coverage under this warranty will be effective only when a copy of the original invoice, showing date and place of purchase, accompanies any claim for warranty. This warranty is NON TRANSFERABLE.

This limited warranty will not cover, in any way or form, any alleged damages caused by incorrect or improper installation, improper use, modification or neglect of product, failure to properly service and maintain, misuse, act of God, accident or failure of the user to follow guidelines contained in the instructional material provided by Automatic.

This warranty does not cover normal wear and tear, paint or rust.

Warrantor assumes no responsibility to the owner for loss of use of product, loss of time, inconvenience or any other damage consequential or otherwise. Including, but not limited to mileage, expense of transporting of product, return shipping expense, mechanics travel time, telephone, road service, towing, and rental during repairs, travel, lodging, loss or damage to personal property or loss of earnings.

REPAIR OR REPLACEMENT AS SET FORTH IN THIS LIMITED WARRANTY IS THE SOLE EXCLUSIVE REMEDY OF THE PURCHASER. AUTOMATIC SHALL NOT BE LIABLE FOR ANY INCIDENTAL OR CONSEQUENTIAL DAMAGES FOR BREACH OF ANY EXPRESS OR IMPLIED WARRANTY ON THIS PRODUCT. EXCEPT TO THE EXTENT PROHIBITED BY APPLICABLE LAW, ANY IMPLIED WARRANTY OF MERCHANTABILITY OR FITNESS FOR A PARTICULAR PURPOSE ON THIS PRODUCT IS LIMITED IN LENGTH TO THE DURATION OF THIS WARRANTY.

Please visit <http://blueox.com/warranty/> to register your warranty

