



DESCRIPTION: TOYOTA TUNDRA MATRIX TOPPER INSTALLATION INSTRUCTIONS ST

APPLICATION: 2022-2024 TOYOTA TUNDRA

PART NUMBER: 112012

KIT CONTENTS:



TOOLS REQUIRED:

- 1) 1/2" WRENCH OR SOCKET
- 2) 3/16" HEX KEY
- 3) TAPE MEASURE

PRE-INSTALLATION WARNINGS, CAUTIONS, CRITICAL STEPS, AND NOTES:

⚠ WARNING

- 1) PERMANENT MODIFICATION OF VEHICLE MAY BE REQUIRED**
- 2) ENSURE ALL FASTENERS ARE TIGHTENED BEFORE OPERATING VEHICLE.**
- 3) INSTALLATION REQUIRES MORE THAN ONE PERSON.**

KIT CONTENTS

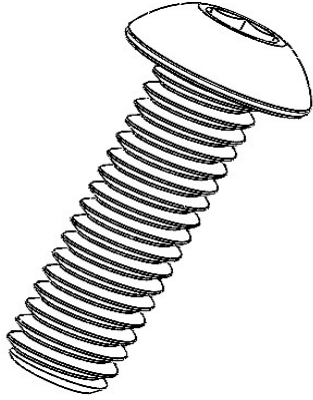

4X BUTTON HEAD
SCREW 5/16"-18

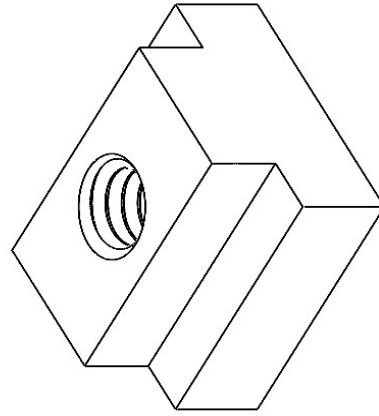

4X T-NUT

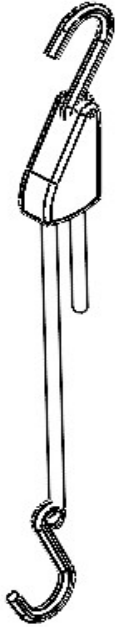

1X ROPE RATCHET

STEP 1) INSERT T NUTS INTO OEM INSTALLED UTILITY RAIL

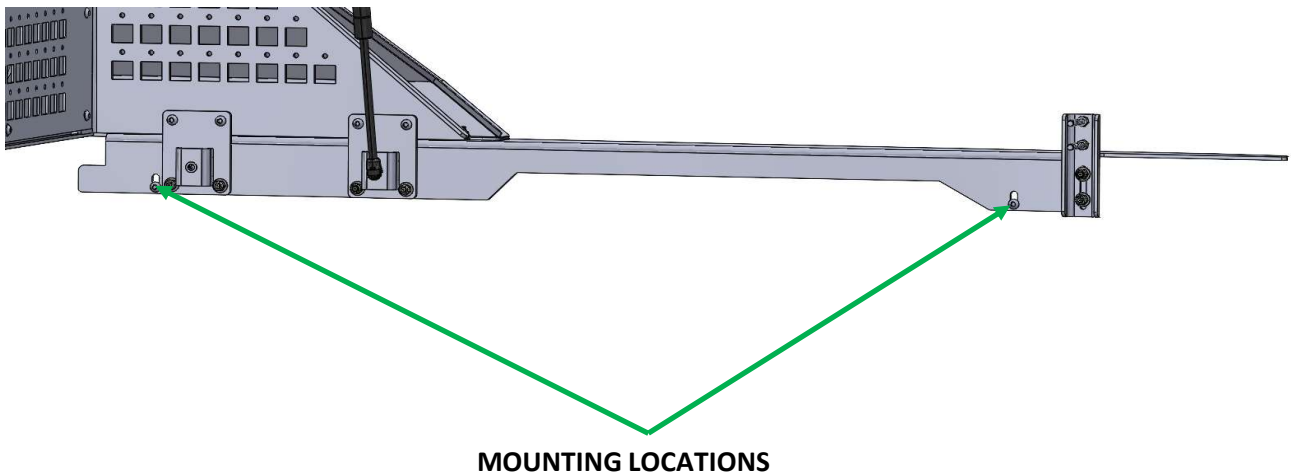

- 1) INSERT TWO (2) T-NUTS INTO THE PASSENGER SIDE UTILITY RAIL, POSITION IN THE GENERAL AREA AS THE MOUNTING SLOTS IN THE TOPPER RAIL. REPEAT FOR THE DRIVER SIDE UTILITY RAIL.**

STEP 2) PLACE THE TOPPER ON THE TRUCK BED (THIS STEP REQUIRES 2-3 PEOPLE)

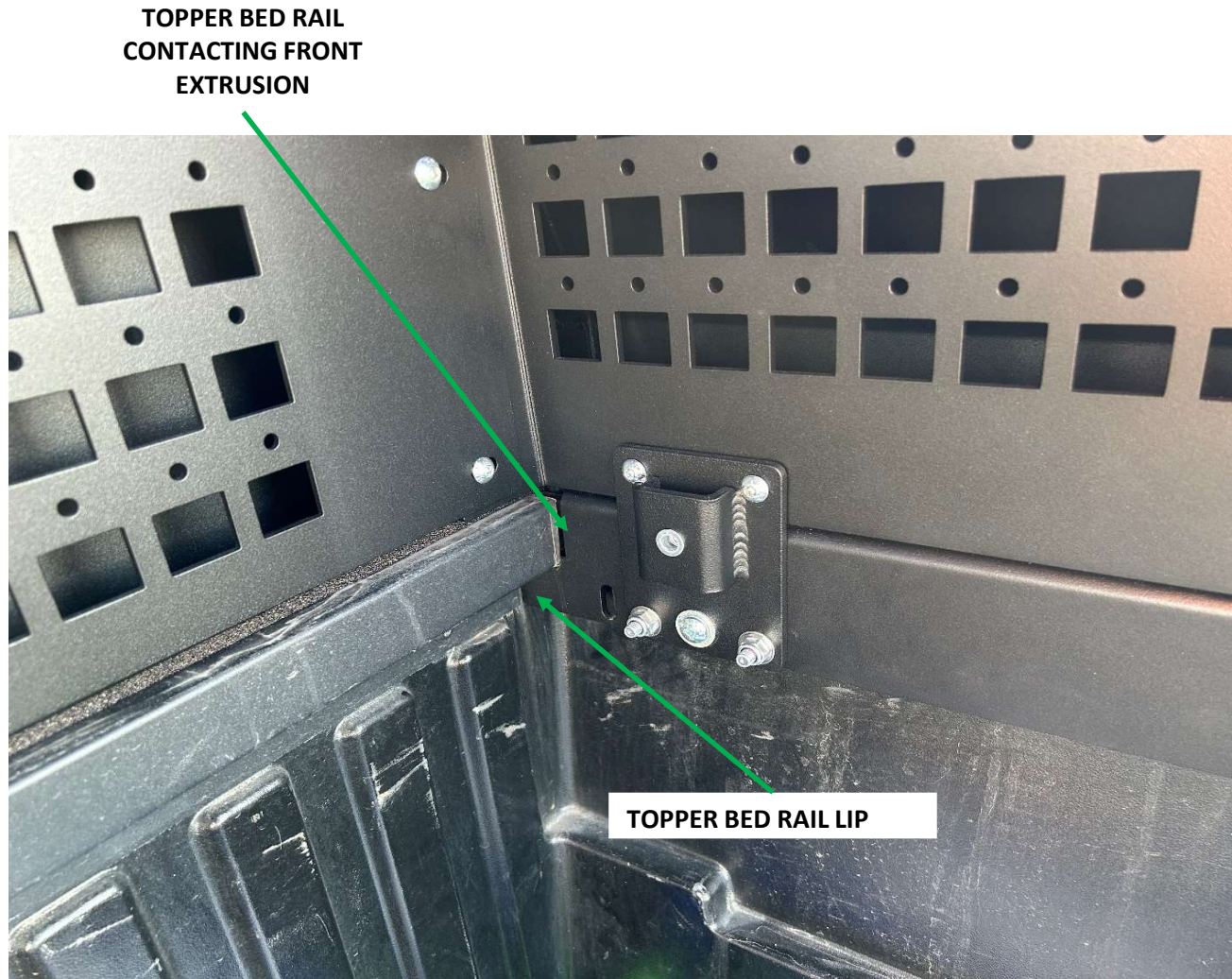

- 2) LIFT AND PLACE THE TOPPER ON THE TRUCK BED. SLIDE THE TOPPER TOWARDS THE FRONT OF THE TRUCK BED. THE LIP ON THE FRONT OF THE TOPPER BED RAIL SHOULD SLIDE UNDER THE OEM INSTALLED EXTRUSION. THE TOPPER WILL BE IN THE CORRECT POSITION WHEN BOTH TOPPER RAILS ARE CONTACTING THE EXTRUSION.**

3) SECURE TOPPER TO TRUCK BED

DS FRONT TO PS REAR MEASUREMENT OF TOPPER BED RAIL

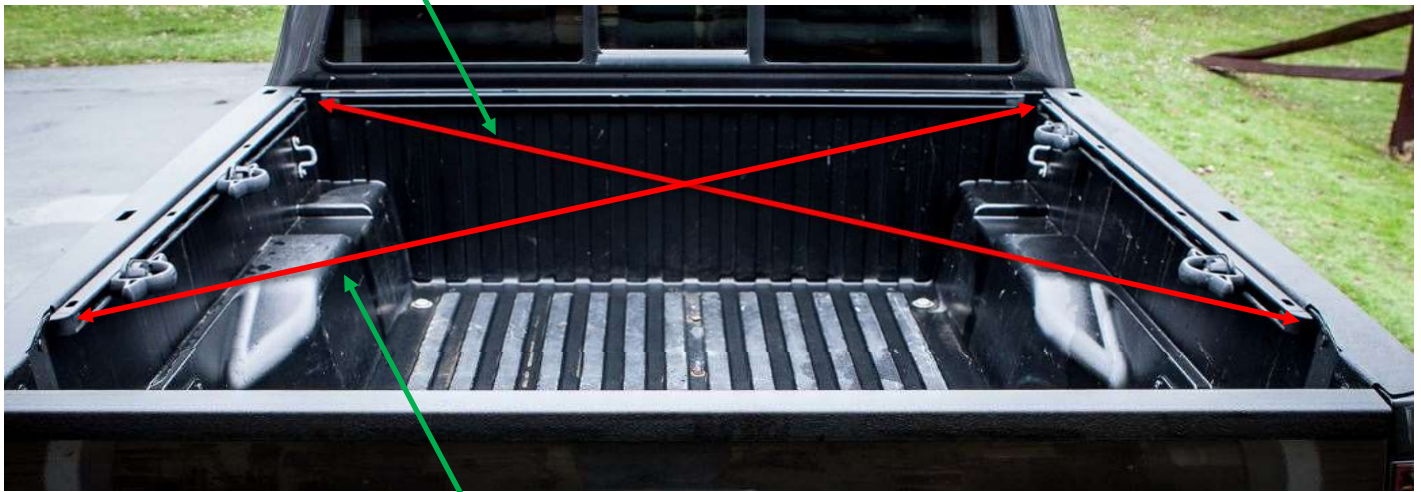

PS FRONT TO DS REAR MEASUREMENT OF TOPPER BED RAIL

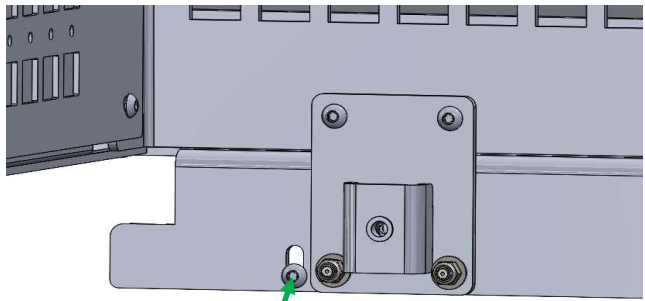

FRONT MOUNTING LOCATION

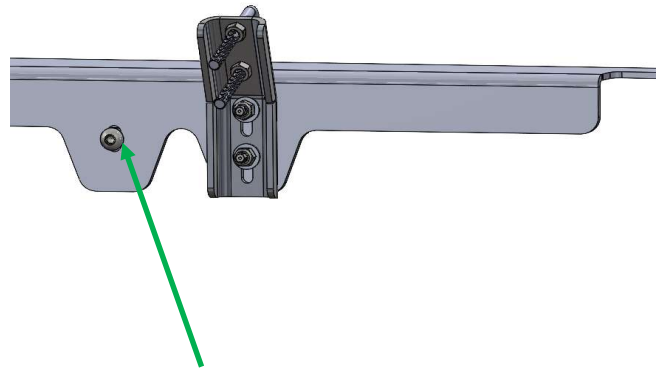

REAR MOUNTING LOCATION

- 3) TO ENSURE THE TOPPER IS SQUARE, MEASURE FROM THE FRONT OF THE DRIVER SIDE RAIL TO THE REAR OF THE PASSENGER SIDE RAIL AND FROM THE FRONT OF THE PASSENGER SIDE RAIL TO THE REAR OF THE DRIVER SIDE RAIL. THE MEASUREMENTS SHOULD BE WITHIN 1/16" OF EACH OTHER. ONCE SQUARE, INSERT THE SUPPLIED 5/16"-18 BOLTS THROUGH THE MOUNTING SLOT AND INTO THE T-NUTS, TIGHTEN DOWN USING A 3/16" ALLEN WRENCH.

STEP 4) LATCH AND CATCH PIN ADJUSTMENT

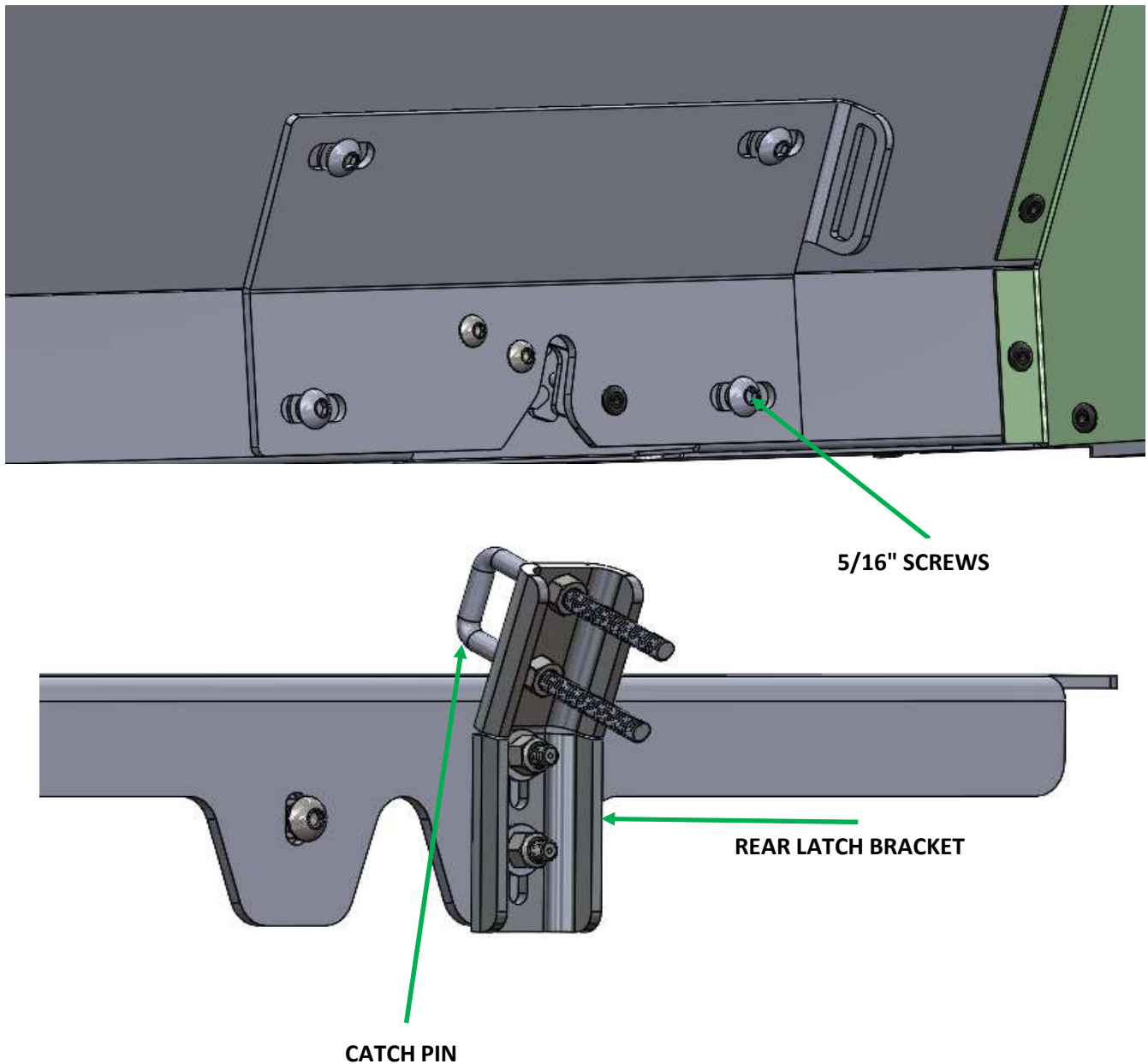

- 4) THE LATCHES MAY NEED TO BE ADJUSTED PERIODICALLY. TO ADJUST THE LATCH POSITION, LOOSEN THE FOUR 5/16" BUTTON HEAD SCREWS SO THAT THE REAR LATCH BRACKET CAN SLIDE EASILY. SLOWLY LOWER THE TOPPER ONTO THE CATCH PIN. CENTER THE LATCH MECHANISM ON THE CATCH PIN. TIGHTEN THE FOUR 5/16" BUTTON HEAD BOLTS USING A 3/16" HEX KEY. REPEAT FOR THE PASSENGER SIDE.

STEP 5) CATCH PIN ADJUSTMENT

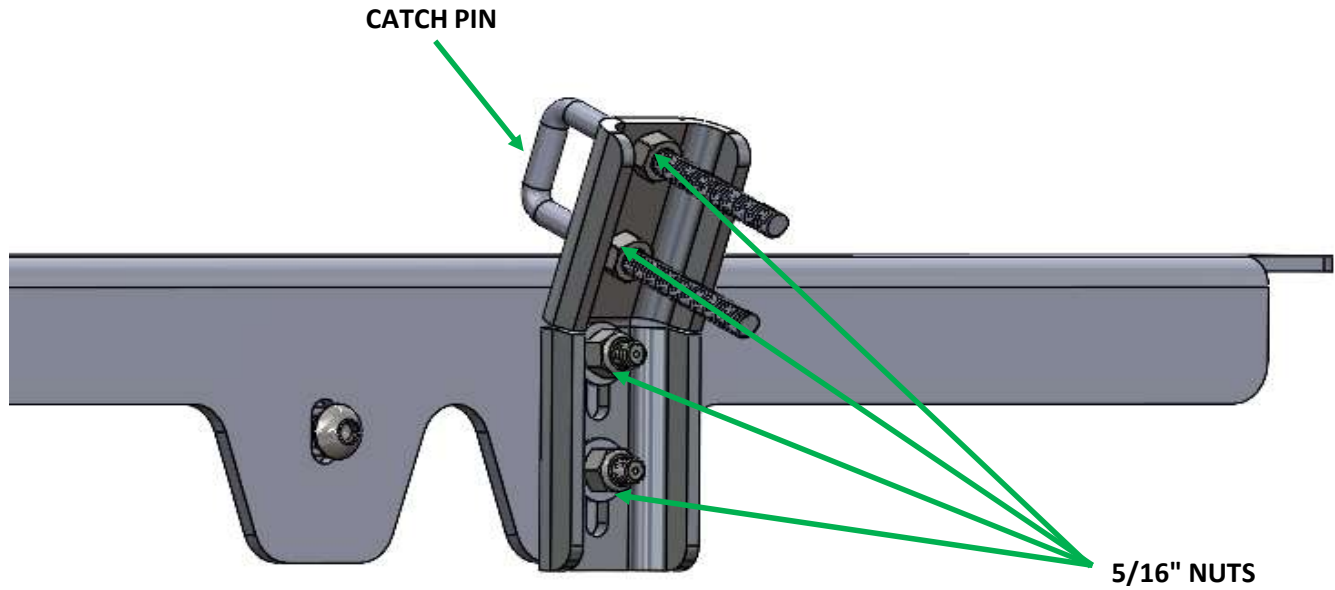

- 5) **CATCH PIN HEIGHT ADJUSTMENT IS NEEDED TO ENSURE PROPER SEAL PRESSURE. TO ADJUST, LOOSEN THE 5/16" NUTS AND RAISE THE CATCH PIN TO INCREASE SEAL PRESSURE AND LOWER CATCH PIN TO DECREASE. THE OPTIMAL CATCH PIN HEIGHT IS MET WHEN NO LIGHT CAN BE SEEN AROUND THE SEAL FROM INSIDE THE TRUCK BED. THE D-RING CAN ALSO BE ADJUSTED IN AND OUT BY LOOSENING THE ATTACHED NUTS. ONCE THE OPTIMAL LOCATION IS MET, TIGHTEN DOWN THE 5/16" NUTS USING A 1/2" WRENCH OR SOCKET.
*PERIODIC ADJUSTMENTS MAY BE NEEDED***