

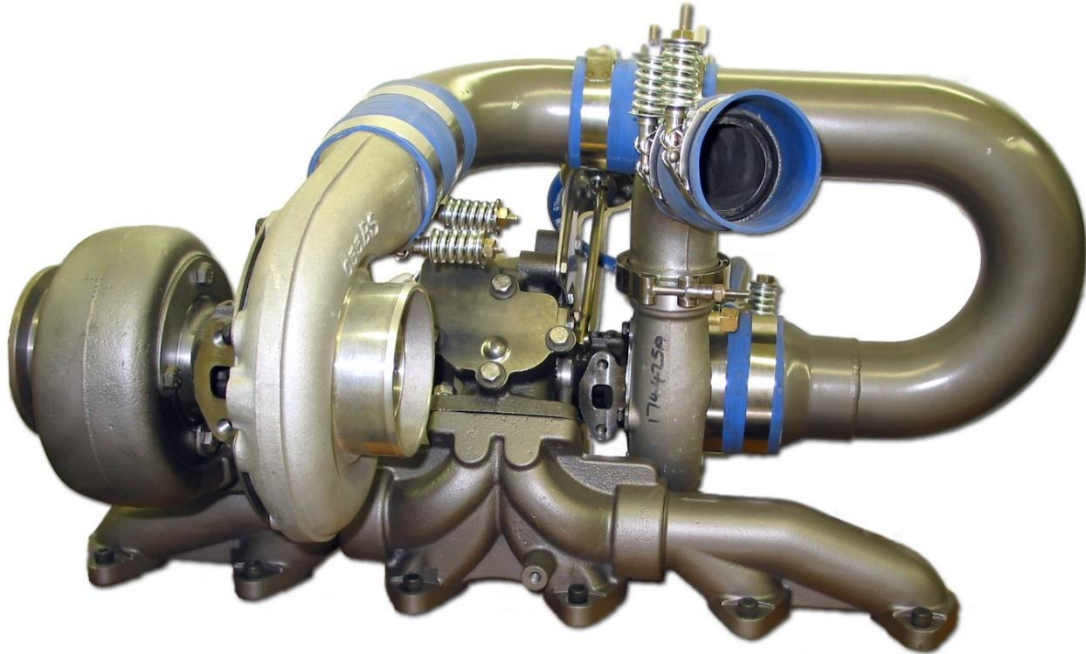

**DOWNLOAD COLOR
INSTALL MANUALS AT
www.bddiesel.com**



BD Dodge Twin Turbo Kit
1994-2002 Dodge Cummins





Part #	Kit	Years	Primary	Secondary
1045310	Super B Twin Turbo	94-98	S366	S358
1045410	RT700	94-98	S472SXE	S358
1045453	RT850	94-98	S476SXE	S364SXE
1045320	Super B Twin Turbo	98.5-02	S366	S358
1045420	RT700	98.5-02	S472SXE	S358
1045456	RT850	98.5-02	S476SXE	S364SXE

PLEASE READ ALL INSTRUCTIONS BEFORE INSTALLATION
Picture shown features recommended optional 3-piece HD Exhaust
Manifold (PN 1045948 / 1045947)





UNLESS AN EO# IS LISTED, THIS PRODUCT IS ILLEGAL IN CALIFORNIA FOR RACING VEHICLES ONLY, WHICH MAY NEVER BE USED UPON A HIGHWAY.

Kit Contents

Super B Twin		RT700		RT850	
1405219		1405219		1415250	
					
S358 Secondary		S358 Secondary		S364 Secondary	
Qty: 1		Qty: 1		Qty: 1	
1405230		S472X100-874125		S476X100-874125	
					
S366 Primary		S472 SXE Primary		S476 SXE Primary	
Qty: 1		Qty: 1		Qty: 1	
1453120	1453405P	1453305P	1453700P		
					
Primary Turbo Bracket	Primary Air Outlet	Secondary Air Inlet	Air Filter to Primary		
Qty: 1	Qty: 1	Qty: 1	Qty: 1		
1453600	1453521	1453502	1459122P		
					
Primary Exhaust Outlet	Turbine Housing Blanket	Hot Pipe	CAC Pipe		
Qty: 1	Qty: 1	Qty: 1	Qty: 1		

148062	1100740	1453602	1453105	1453106
				
Oil Drain Gasket	4" SS Lap Clamp	V-Band Clamp	Primary Drain 11"	Secondary Drain 23"
Qty: 2	Qty: 1	Qty: 1	Qty: 1	Qty: 1

Air Box Kit (1453892)





1453805T	2924	1505016	1100112	1453801
				
Air Box	4" Air Filter	Nut; M6	Washer; 1/4"	Spacer
Qty: 1	Qty: 1	Qty: 3	Qty: 3	Qty: 1

Hardware Kit (1453292)



1452813	1453982	1453983	1604102
			
3/8"x24-1.75	Nut; Lock 3/8x24	Washer; 3/8x.8	Washer; Lock M8
Qty: 2	Qty: 2	Qty: 4	Qty: 2
1030099	1453113	1453316	1405912
			
Bolt; M8 - 25	Clamp; 1/2"x1-1/4"	Spacer Plate; T3	Gasket; T3
Qty: 2	Qty: 2	Qty: 2	Qty: 1
2485012	1453139	1453121	1453122
			
T4 Single Gasket	1/4" NPT to Inv Flare	Bolt; M12x1.75-25	Washer; M12
Qty: 1	Qty: 1	Qty: 1	Qty: 1

1453503	1453115	1453504	1405926	
				
Heat Shield	Fitting; 1/8NPT x -6JIC	Zip Tie; SS	Clamp; Super B	
Qty: 1	Qty: 1	Qty: 3	Qty: 1	
1462430	1462441	1452825	1452826	
				
Stud; M10x1.5-30	Nut; M10x1.4	Bolt; M10x1.5x25	Washer; Lock M10	
Qty: 4	Qty: 4	Qty: 2	Qty: 2	
1453152	1453130-B	1120031	1453162	1120030
				
Fitting; 1/4NPT x -6 ORFS	Primary Oil Feed Hose	Washer; 3/8"	Fitting; 1/4NPT x -6JIC	Bolt; 3/8"-1 1/4" NC
Qty: 1	Qty: 1	Qty: 2	Qty: 1	Qty: 2
1453161	1462446	FT-11116340	1452825	1130315
				
-6JIC 90 Deg	Nut; 1/4" Lock	M8 1.25	M10 1.5	3/8" X1
Qty: 1	Qty: 2	Qty: 2	Qty: 2	Qty: 2



Boot and Clamp Kit (1453489)

1405222	1405221	1405213	1405211	1453701
				
4" ID Hose	3" ID Hose	Clamp (4.11")	Clamp (3.25")	Clamp (4")
Qty: 2	Qty: 2	Qty: 2	Qty: 4	Qty: 2



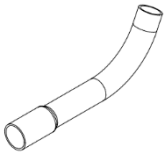

RT 700/850 Kits Only

1405229	1405237
	
<p>5" To 4" boot Qty: 1</p>	<p>5.5" Clamp Qty: 1</p>

1994-1998 Trucks Only

1045981	1453148	3959052	3938157
			
<p>Manifold Gasket Set Qty: 1</p>	<p>Primary Oil Drain Qty: 1</p>	<p>Oil Pan Gasket Qty: 1</p>	<p>Oil Pump Gasket Qty: 1</p>

1998.5-2002 Trucks Only

1459130	1459140	1300131	1045986
			
<p>Heater Tube Coupler Qty: 1</p>	<p>Heater Tube Clamp Qty: 1</p>	<p>Zap Strap Qty: 2</p>	<p>Gasket Set; 24V Qty: 1</p>

1998.5-2002 RT 700/850 Cooler Relocation (1453184)









1453118	1407030	1452816	1452817	1452818
				
Mounting Bracket	3 1/2" Band Clamp	Bolt; 7/16" x 3.5"	Washer; 7/16"	Lock Washer; 7/16"
Qty: 1	Qty: 2	Qty: 2	Qty: 2	Qty: 2
1452819	1604048M	1452820	1604049	1604054
				
Nut; 7/16"	1/4" NPT x -8 JIC	5/8" Barb	-8JIC F x 1/2" Barb	1/2" Trans Hose
Qty: 2	Qty: 1	Qty: 1	Qty: 1	Qty: 96
1452821	1300130	1604037	1604056	1400105
				
Gear Clamp	Zip Tie	1/2" NPT x 1/2" Barb	5/8" ID Heater Hose	3/8" NPT x 1/2" Barb
Qty: 10	Qty: 12	Qty: 1	Qty: 74	Qty: 1

Table of Contents

Kit Contents 2

 Air Box Kit (1453892)..... 3

 Hardware Kit (1453292)..... 3

 Boot and Clamp Kit (1453489)..... 4

 RT 700/850 Kits Only..... 5

 1994-1998 Trucks Only..... 5

 1998.5-2002 Trucks Only..... 5

 1998.5-2002 RT 700/850 Cooler Relocation (1453184)..... 6

Table of Contents..... 6

Introduction..... 7

Options 7

Installation..... 8

 Installing with a stock manifold..... 10

 Installing with an aftermarket manifold 10

 1998.5-2002 RT 700/850 Heat Exchanger Relocation 10

 Engines WITH a frost plug 17

 12V Engines WITHOUT a frost plug 18

Twin Turbo Testing 23

Wastegate Adjustments 23

Introduction

For the purpose of the instruction manual, the term “primary turbo” refers to the larger non-wastegated turbo and the term “secondary turbo” refers to the smaller manifold turbo.

Installation should occur on a cold vehicle, as turbo and exhaust components become very hot with use.

Also note that a stock transmission will not handle this power and torque, transmission modifications are required.

Options

<i>Description</i>	<i>Part #</i>
BD 'X' Torque Converter	1070215X
BD Transmission	CALL
BD High Flow Injectors	CALL
Head Studs	CALL
BD High Pressure Intercooler Boots	1045210

WHEN EITHER UPGRADING OR INSTALLING THE TWIN TURBO KIT THE WASTEGATE WILL NEED TO BE ADJUSTED. THIS WASTEGATE IS ADJUSTABLE BY TURNING THE ACTUATOR ROD. SEE THE SECTION AT THE END IF THE INSTRUCTION MANUAL FOR COMPLETE DETAILS.

YOU SHOULD RUN AS MUCH BOOST AS POSSIBLE TO KEEP YOUR EGTS IN CONTROL. IF THIS MEANS RUNNING 65PSI OF BOOST PRESSURE, THAT IS FINE, JUST KEEP YOUR EGTS AS LOW AS POSSIBLE. THE KIT WILL PERFORM BEST WHEN THE WASTEGATE IS CLOSED AS LONG AS POSSIBLE.

USE YOUR FUELING (ELECTRONIC OR MECHANICAL) TO CONTROL YOUR BOOST LEVEL NOT THE WASTEGATE. THIS WILL RESULT IN LOWER EGTS, BETTER FUEL ECONOMY AND A QUICKER SPOOLING TURBOCHARGER.

Installation

1. Disconnect the negative terminals on both of the vehicles batteries, then disconnect the positive terminals.
2. Lay a protective cover over the passenger side fender to eliminate any scratches.
3. Remove the air box assembly and intake tube from the inlet of the turbocharger.
4. Remove the two 13mm bolts connecting the exhaust down pipe to the turbo flange.
5. Remove the cast aluminum elbow attached to the turbo compressor housing outlet. You will need to loosen the 'V' band clamp and the band clamp with a 7/16" deep socket. Be sure not to lose the o-ring from the aluminum elbow, as you will re-use the aluminum elbow assembly later.
6. Remove the black steel intercooler tube. You will need to loosen the band clamp on the intercooler using a 7/16" deep socket.
7. Remove the turbo oil feed line (top of turbo) from the turbo by holding the 19mm turbo fitting with a wrench and remove the 13/16" line fitting – place line to the side. As well you may now remove the 19mm oil feed fitting.

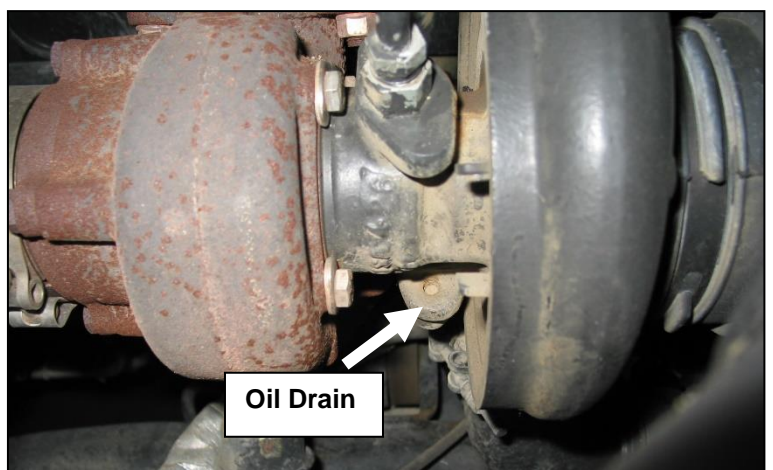
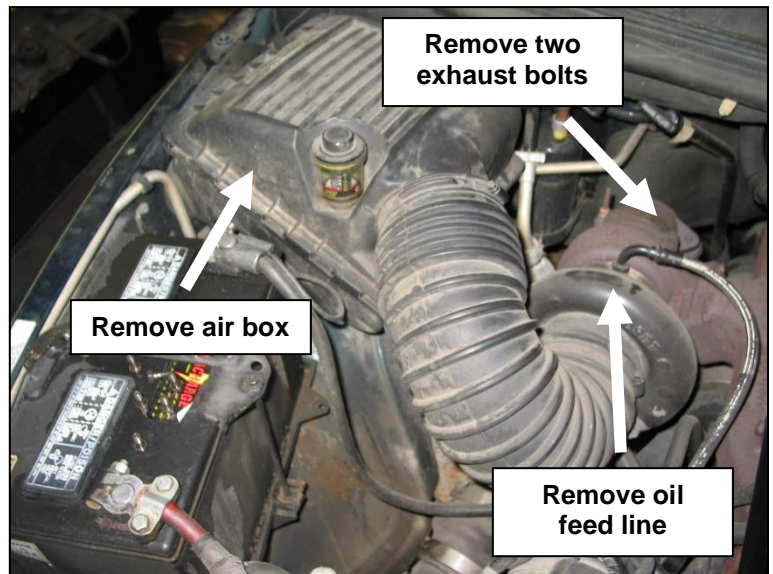

8. Unbolt the turbo oil drain tube from the bottom of the turbo by removing the two 10mm bolts.

9. Remove the lower hose clamp on the turbo oil drain boot and remove the oil drain tube and hose as an assembly as you will need to re-use the hose.

10. Re move the four nuts holding the turbo to the exhaust manifold with a 15mm wrench– remove the stock turbo and set it aside.

11. Remove the stock down pipe and intermediate pipe from the exhaust system.

12. Remove the nut holding the heater core line to the exhaust manifold stud using a 15mm socket. 1998.5-2002 trucks, remove spring clamps and line.

13. Remove the exhaust manifold bolts with a 13mm socket. Remove the spacers and finally the manifold at this time. Be sure not to lose the spacers.

14. Discard all exhaust manifolds gaskets and clean then engine block and exhaust manifold mating surface.

15. Reinstall the exhaust manifold in an inverted manner so the turbo flange faces upward. Use the provided manifold gaskets and the factory bolts, spacers and retainers and torque to 32 ft lbs with a 13mm socket.

Note: If you have purchased a heavy-duty aftermarket manifold, you will need to use the provided 1 or 2 spacers for the compressor cover to clear

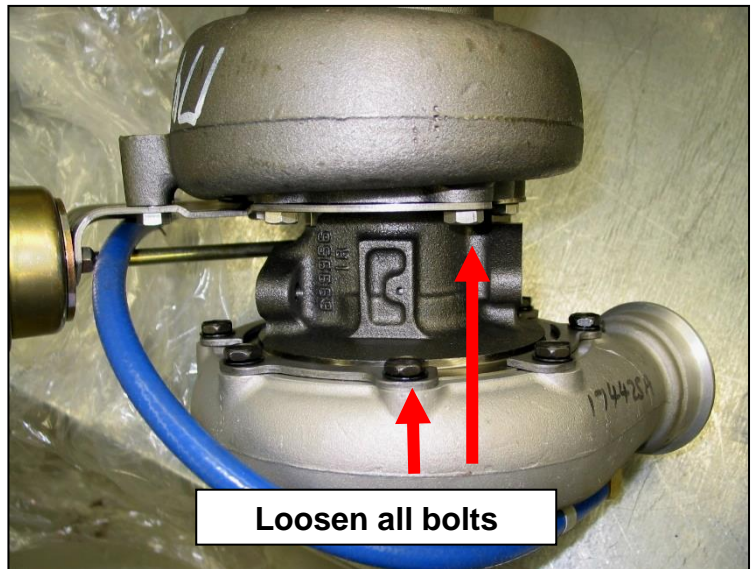

Installing with a stock manifold

16. Mount the turbo to the manifold using the two factory studs and nuts, the supplied gasket, two 3/8" X 1-1/2 NF bolts, two 3/8" nuts and the four 3/8" flat washers. You will need to use two separate 9/16" wrenches.

Installing with an aftermarket manifold

17. Check the hardware from the purchased HD manifold, be sure to install the manifold with the flange facing upwards. Use 1 or 2 provided T3 spacer plates (1453316) and gaskets (1405912) to allow the compressor cover to clear the manifold.
Use either the provided 3/8" bolts/nuts in place of the two open holes in the manifold or the supplied manifold hardware.



1998.5-2002 RT 700/850 Heat Exchanger Relocation

1994-1998 Trucks skip to step 35

18. 1998.5-2002 trucks will need to relocate their heat exchanger to make room for the larger primary turbocharger. Locate the transmission heat exchanger located on the passenger side rear of the engine. It is roughly 9" long and 3" in diameter and painted black.
19. Disconnect the transmission oil cooler lines at the heat exchanger using a 7/8" wrench.
20. Disconnect transmission oil cooler line at the Driver's side front of the transmission using a 3/4" wrench. Then disconnect the 1/4" hose clamp connection under the driver's side underneath the radiator.
21. Remove transmission cooler lines, note that there will be plastic locking clips that secure the line to engine that will also need to be removed.
22. Disconnect the two coolant lines from the front of the heat exchanger. These connections are secured using spring clamps.

Stock

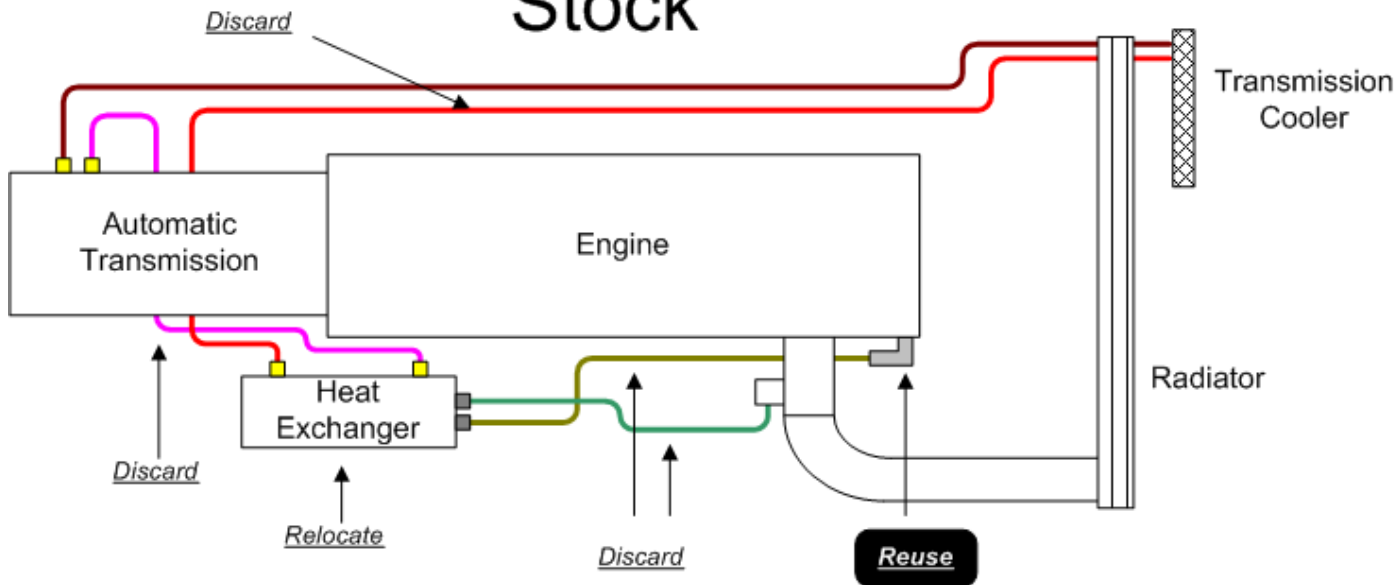

23. Then disconnect the coolant line at the front passenger's side of the engine from the 90° rubber bend/elbow. Just loosen the hose clamp to release the hard line. Note that you will need to keep this 90° rubber bend/elbow in place.

24. Remove the coolant line at the side of the aluminum distribution block beside the lower radiator hose.

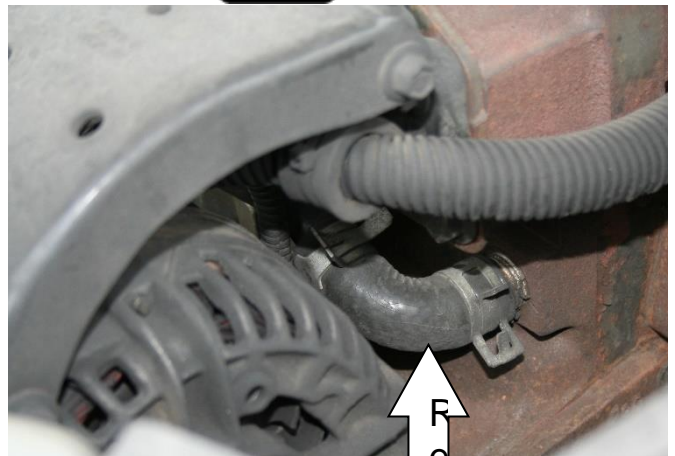

DO NOT REMOVE THE PASSENGER CAB HEATER CORE COOLANT LINE

25. Now locate the 4 mounting bolts for the heat exchanger, 2 on the bell housing and 2 on the engine. Use a 17mm wrench to remove the 4 bolts.

26. With the heat exchanger removed you will need to cut off the factory mounting brackets. You will obviously need to be careful as not to cut through the outer shell. Cut the weld sections of the bracket to the point they are flush with the OD of the heat exchanger. Paint the heat exchanger black to protect the unit against corrosion.

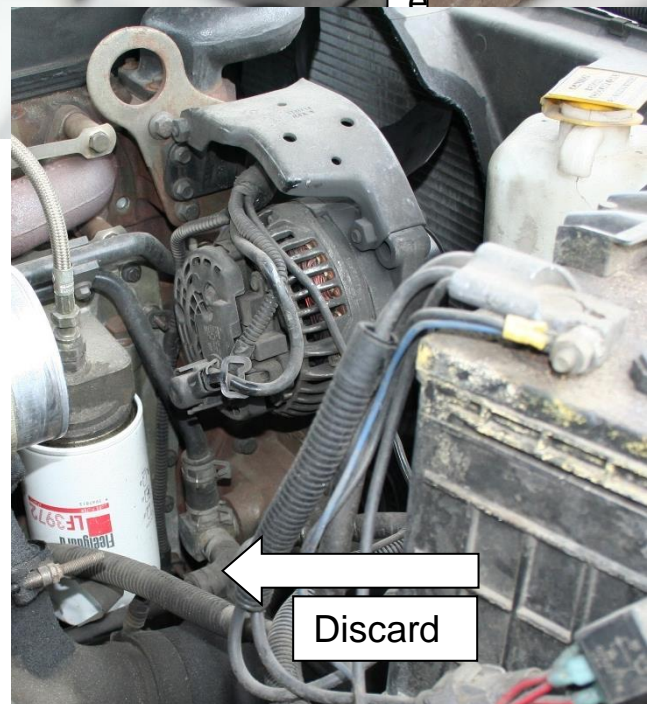

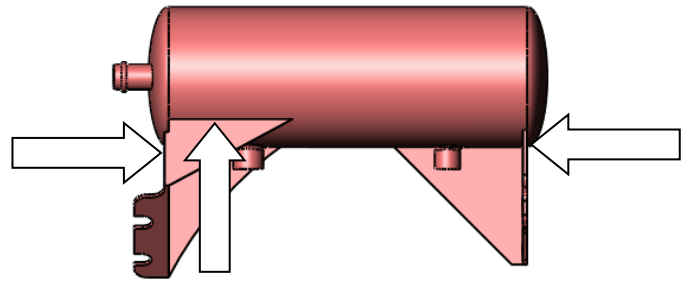
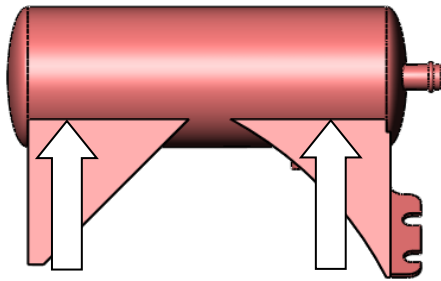

27. Before installing the heat exchanger, install the 1/2" MNPT x 1/2" barb fitting (1604037) into the NPT port closest to the coolant in and out ports. Be sure to use pipe sealant to seal the connection.

28. Now install the 3/8" MNPT x 1/2" barb fitting in the remaining NPT port. Be sure to use pipe sealant to seal the connection.

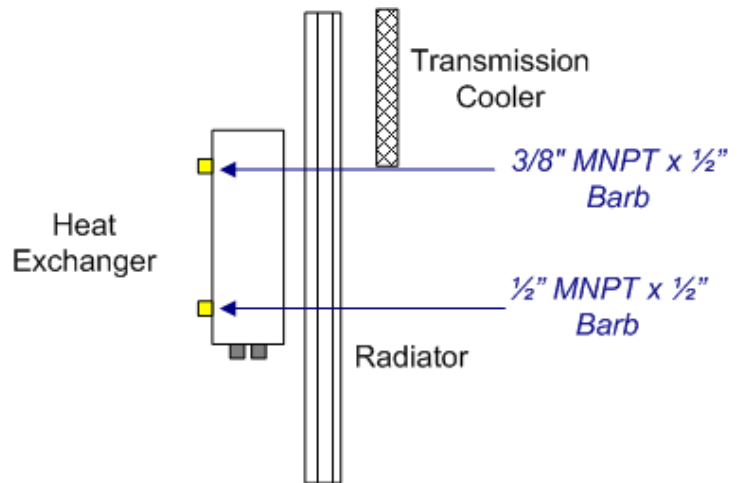

29. With the heat exchanger removed, locate the front cross member underneath the engine fan. This will be the new mounting location of the heat exchanger.

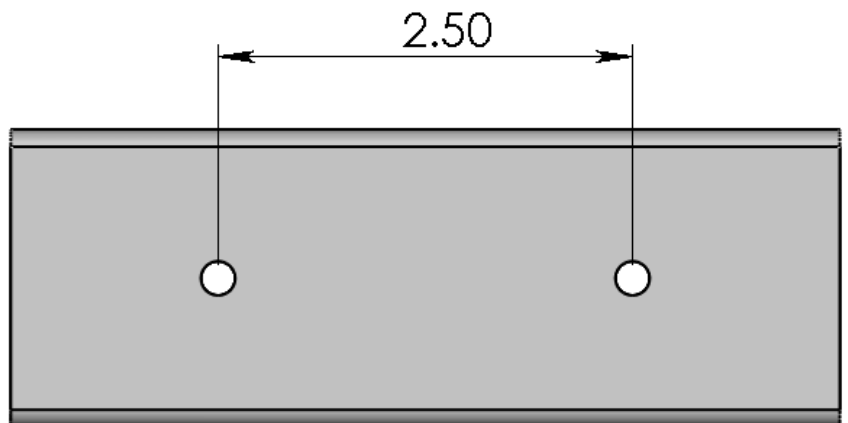

30. Using a drill, drill a 1/2" hole in this cross member from the rear of cross member towards the front of the truck. These holes should be roughly centered on the cross member and about 2.5" center to center.

31. Then secure the two mounting brackets

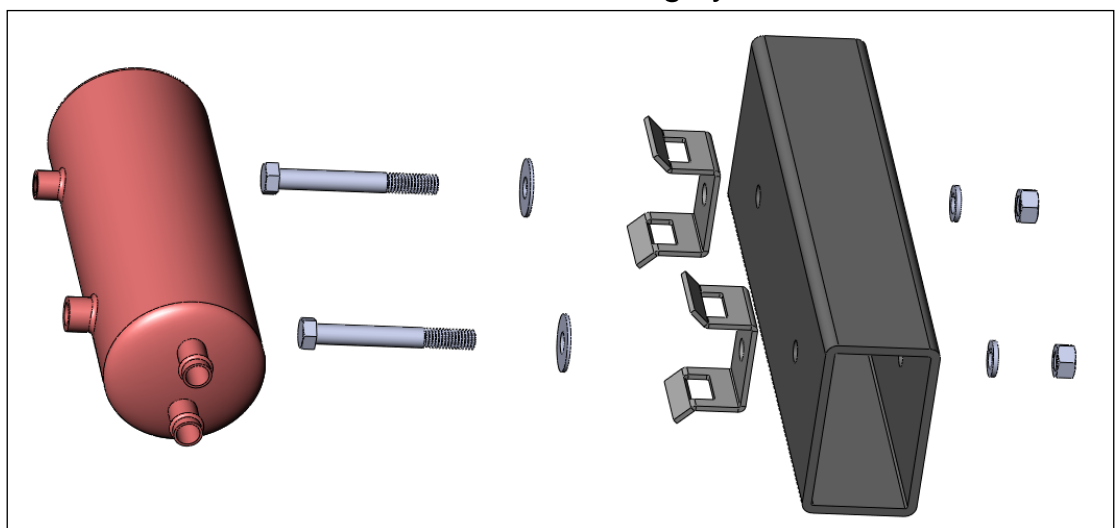

(1453118) to the cross member using the 7/16" mounting hardware(1452816, 1452817, 1452818, 1452819). Torque the bolts to 20 ftlbs. Note that the "windows" or rectangular clamp cutouts should be vertical.

32. Unscrew the 3.5" band clamps (1407030) completely. Then remove the "Bridge" this will allow you to insert the clamp through the open "windows" on the mounting brackets.

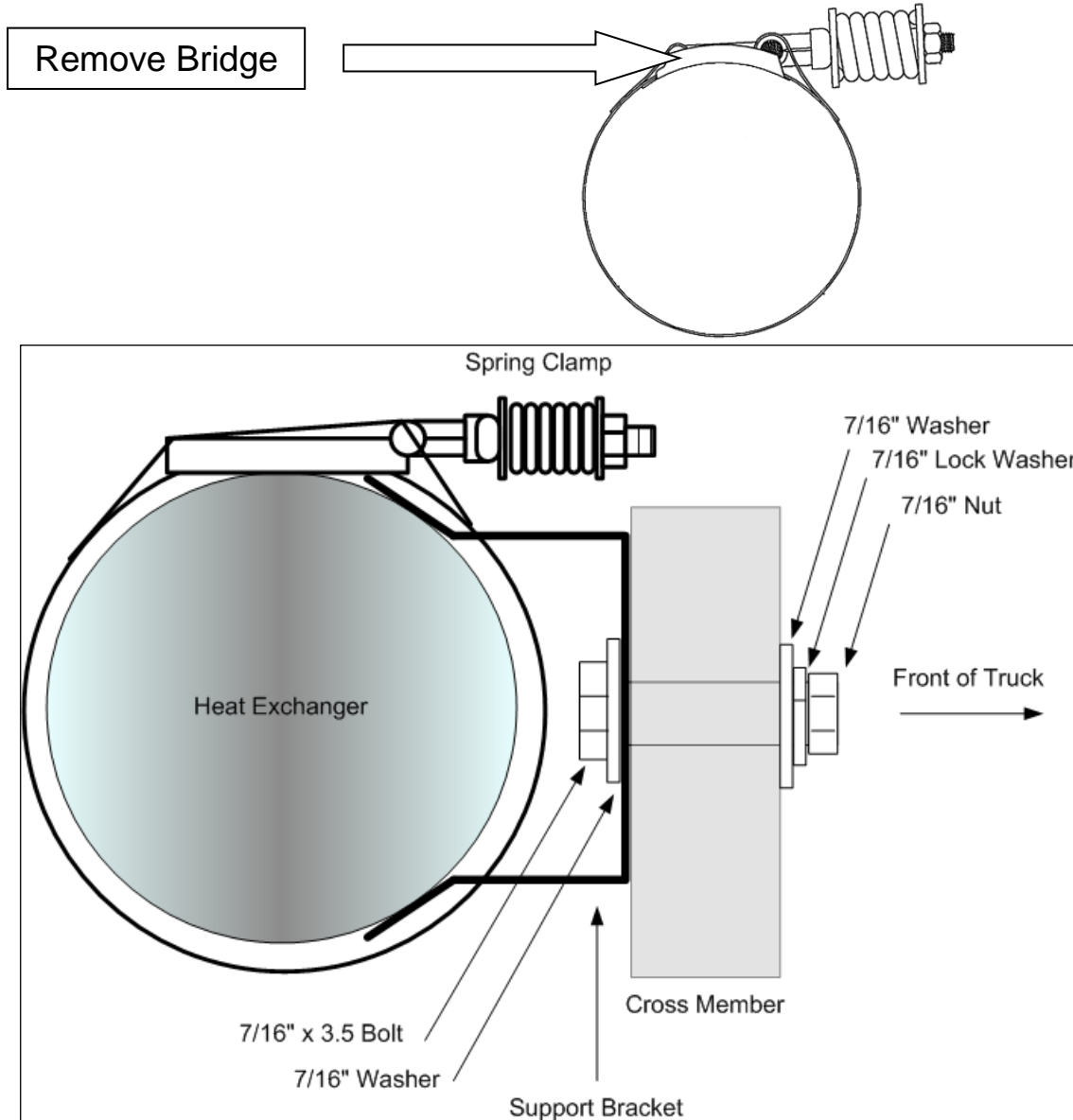

33. Once the two clamps have been inserted through the two windows on each bracket you can lift the heat exchanger into place. Wrap the band clamps around the heat exchanger and tighten to 30inlbs. Note that the water inlet/outlet should be placed on the passenger side. With the oil inlet/outlet pointing towards the rear of the vehicle.

34. With the heat exchanger mounted you can now route the selected hoses.

- 1/2" ID Black Hose = Oil
- 5/8" ID Black Hose = Coolant

All the OIL (Blue Hose) lines will run along the Driver's side of the vehicle, while the COOLANT lines (Black Hose) should run along the passenger's side of the vehicle.

Altered

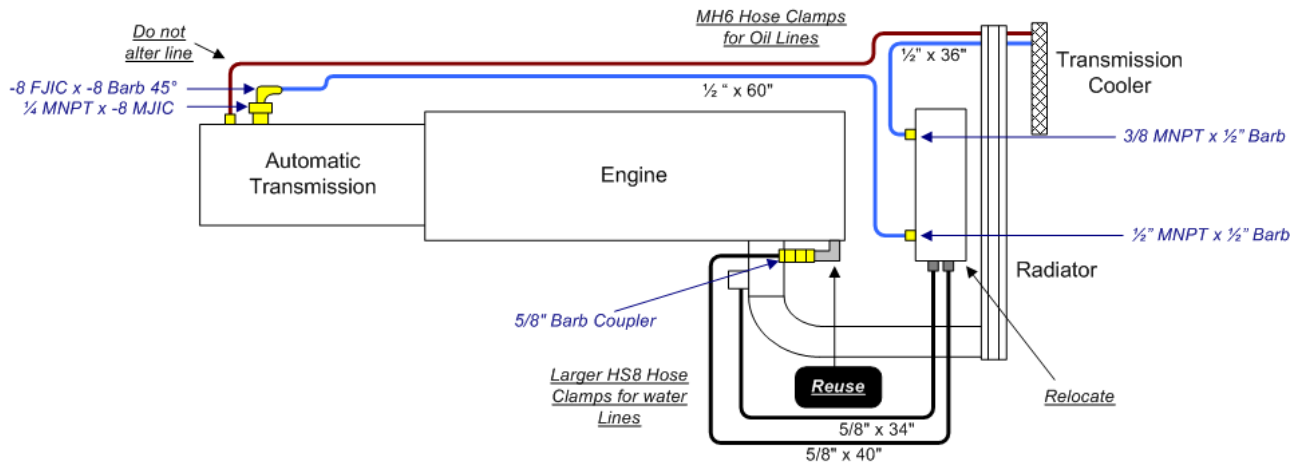

Using the 90° formed rubber hose that you saved earlier, install it on the passenger side front of the engine cylinder head. Secure the connection using a HS8 clamp. On the other side of the rubber 90° insert the 5/8 barb coupler (1452820). Secure the connection with another HS8 clamp.

You can now insert the coolant hose onto the 5/8 barb coupler and route the hose towards the front and to the relocated heat exchanger. You should use roughly 40" for this operation, but trim for the best fit. Secure all connections using the HS8 clamps.

Now using the 34" of coolant hose leftover, connect one side to the coolant discard elbow on the front of the engine, mid level passenger side. Secure this connection with a HS8 clamp.

Route the coolant hose to the heat exchanger mounted at the front, connect the hose to the last coolant connection and secure using a HS8 hose clamp. Trim excess hose. Secure all loose hose points with zap straps.

THERE ARE A NUMBER OF POTENTIAL CHAFING POINTS FOR THE COOLANT HOSE. EACH APPLICATION WILL BE SLIGHTLY DIFFERENT FOR THESE LOCATIONS.

YOU CAN DOUBLE WRAP THE HOSE AT THESE POINTS TO PROVIDE TWICE THE PROTECT. SECURE THE DOUBLE WRAP USING THE PROVIDED ZAP STRAPS.

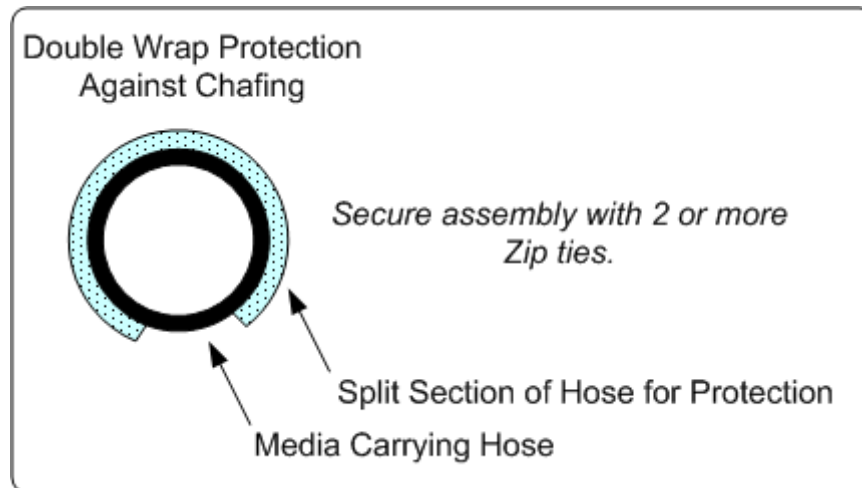

You can now start on routing the transmission oil lines. First connect the $\frac{1}{4}$ MNPT x -8 MJIC (1604048M) fitting to the transmission cooler port on the driver's side of the transmission. Use a small amount of pipe sealant on this application, thread the fitting in by hand and then using a wrench give it one more turn and no more. Do not over torque.

Then install the -8JICx $\frac{1}{2}$ " Barb 45° fitting onto the NPT fitting you just installed. Tighten the fitting; be sure not to allow the NPT fitting to turn while doing this.

Connect the $\frac{1}{2}$ "ID transmission oil hose to this new barb connection and secure using the MH6 Hose clamp. Route the hose alongside the motor towards the front of the vehicle towards the newly mounted heat exchanger.

Trim hose to correct length (roughly 60") and install hose onto the $\frac{1}{2}$ "MNPT x $\frac{1}{2}$ " barb fitting. Secure using MH6 clamp.

With the remaining section of hose, install on the $\frac{3}{8}$ "MNPT x $\frac{1}{2}$ " barb and secure with a MH6 clamp. Then route this connection to the transmission cooler spout that you removed a hose from earlier. Trim excess hose and secure this connection using a MH6 hose clamp. Tie up and loose hose using the provide zap straps.

35. Remove the primary and secondary turbos from their boxes and remove any paper that may be in the inlets or outlets. It is critical that nothing is left inside of the turbos. Prepare them for install.

36. On both turbos, loosen the 4 bolts (1 turn only) that secure the exhaust turbine housing to the turbo CHRA with a 13mm wrench.

Then, loosen the 8 bolts that are securing the turbo compressor housing to the CHRA with a 13mm wrench. This will allow the two housings to rotate freely.

Be careful not to loosen the housings off too much as they will fall off and possibly damage the turbo wheels. The clamps should only be loose enough to clock the housings.

37. On RT850 kits for the 1998.5-2002 thread the 1/4NPT to -6ORFS (1453152) into the secondary turbo. 1994-1998 RT850 will use the 1/4" NPT to inverted flare (1453139).

38. Locate the supplied 1/4MPT x -6JICM fitting (1453162), apply a very small amount of pipe sealant on the threads (DO NOT USE TEFLON TAPE). Now thread the fitting into the primary oil inlet, hand tighten then using a wrench turn the fitting 1/2 turn. DO NOT OVER TIGHTEN.

39. Locate the cast flanged turbine adapter, and wrap the supplied heat shielding around the adapter. The heat shield has been formed in a specific pattern to completely wrap around the elbow. Use the 3 supplied stainless steel zip ties to secure the heat shield. One at the bottom, one at the middle and one at the top. Be sure that neither the heat shield or zip tie will interfere with the circular marmon flange when the band clamp is applied.

40. You can now bolt the flanged turbine adapter to the primary turbo. Use the four M10x1.5 studs and serrated nuts to secure the adapter pipe to the turbo. At the same time mount the SS primary turbo support bracket to the assembly. Use the provided T4 gasket (2485012).



Note that the support bracket bolts on the bottom side of the turbine housing.

41. Place the turbo and turbine adapter assembly onto the frame rail in a location close to the final install point. Be sure that it does not fall.

42. With the secondary turbo, bolt it loosely to the manifold and align the oil inlet straight up and the compressor outlet towards the bottom of the passenger battery.

43. Using the supplied v-band clamp (clamp will be labeled 1405926) tighten the secondary exhaust housing to the primary turbo-turbine adapter assembly.

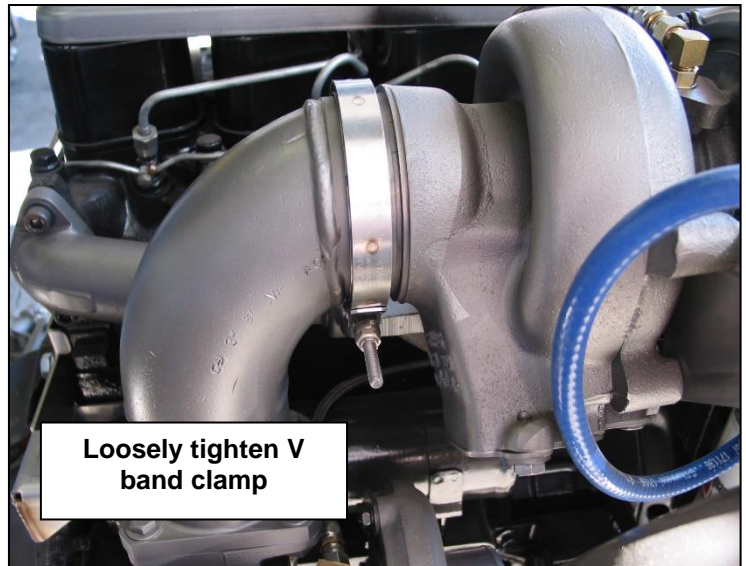

Make sure that heat shield or stainless zip tie does not interfere with the band clamp. Tighten the v-band clamp just enough so that you can still rotate the exhaust elbow.

44. Install the primary turbo support bracket to the engine block with the supplied bolt (12mm x 1.75 x 25) and lock washer. Now tighten the bolts and V band clamp.

Now that the exhaust housings are in their proper locations, the turbo center sections can be twisted so that the turbo oil feeds are pointing straight up and drains are pointed at the block adapters. Tighten the exhaust housing bolts. Note that you may adjust the factory block oil drain adapter to help align the system.

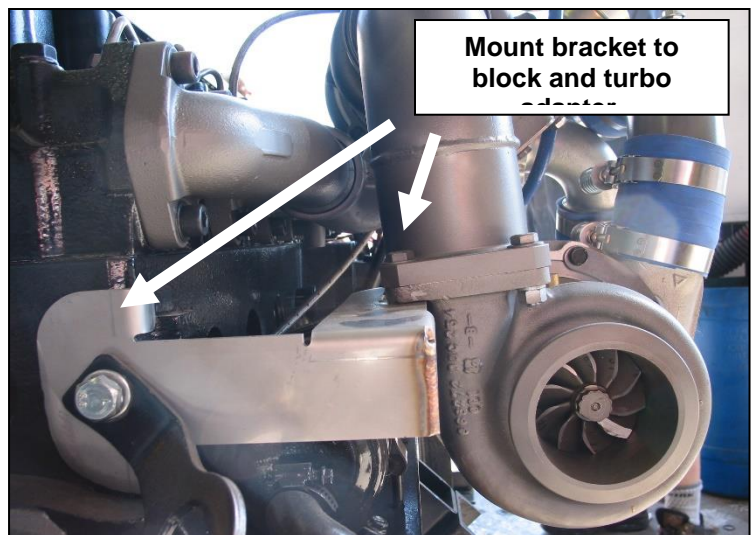

Engines WITH a frost plug

Engines without a frost plug proceed to step 46

45. On the lower right side of engine, 6" from the rear of the engine block (just above the oil pan), there is a frost plug that caps an oil drain port that leads to the engine crankcase. This frost plug needs to be removed to serve as the oil drain for the *primary turbo*.

Great care needs to be taken when removing the frost plug so that it isn't forced into the oil pan.

The frost plug can be removed by coating a drill bit with grease (to catch any metal shavings) and by drilling a small hole in the center of the frost plug. Insert a sheet metal screw into the hole and pry the frost plug out with a pair of pliers.

12V Engines *WITHOUT* a frost plug

Engines without a frost plug proceed to step 58

46. Drain engine oil and leave out drain plug.

47. Clean off paint on the side of the pan between 3rd and 4th bolt from the rear of the engine as shown. This should be done before drilling the hole.

48. Center punch the pan 1 3/16" from inside of the top lip (or 1" from lip) between the 3rd and 4th bolts



49. Cut the marked oil drain hole using a 7/8" hole saw. You may want to use grease to ease the cleaning of the pan later on.

50. Clean the pan with brake clean and install supplied tube in the hole and with the silicone hose to the turbo drain tube you installed earlier, make sure to use the supplied clamps to secure it so it won't move while welding.

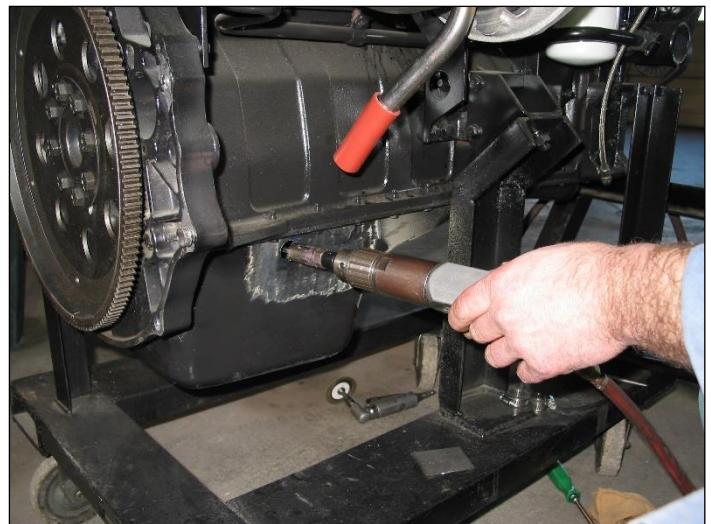

51. Clean the inside of the supplied oil drain tube and tack weld the tube (1453116) into the pan, then remove the silicone hose and clamps.

52. Unbolt oil pan, pull down pan to gain access to the oil pickup tube, unbolt the pickup tube and drop it into the pan. To remove the oil pan you will have to unbolt engine mounts and raise the engine. As well unbolt the fan otherwise it will contact the shroud.

53. Once the pan is removed, clean pan thoroughly making sure to get all the debris out of the inside on the pan and complete the welding of the oil drain adapter.

54. Clean and paint any bare metal areas of the oil pan to reduce corrosion.

55. Place the clean oil pickup tube in the pan, while placing the new pan gasket on the outside of the pan. Now slide the pan into place. You will need to insert the pickup tube gasket in place before tighten the oil pickup tube to 18 ft lbs. This step is rather tight; you will have to slide your arm into place.
56. Once the oil pickup tube has been installed, you can tighten the pan bolts to 18 ft-lbs.
57. Reinstall/Retighten the engine mounts (75 ft lbs), as well install the oil drain plug with the gasket, and fill with 11.5 quarts of fresh oil.

58. The new corrugated tube will slide into the swaged oil pan drain tube. Both turbo oil drains should now be installed.

59. **1998.5-2002 trucks.** If your heater feed tube runs below your exhaust manifold, remove it and cut off the support bracket in half as shown. Clean off the powder coat and loosely install the brass coupler and reinstall the line with original hose clamps. This

will allow you to position the rearward end between the turbo and manifold and hook it back up to the factory rubber hoses. Once positioned, tighten the brass coupler and install the new support clamp to the oil filter housing bolt. Zap strap the two rubber heater hoses to secure them together.

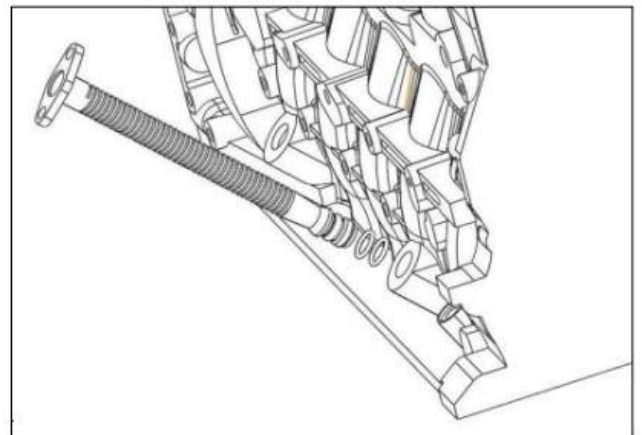

60. Install the factory oil feed line into the 19mm oil feed adapter that will be installed in the secondary turbo (hold the fitting with a 19mm wrench and tighten the line with a 13/16" wrench), this line should run on the engine side of the turbo.



61. Install the 90° Oil feed adapter onto the 1/8NPT-JIC fitting (1453115) fitting you installed into the oil filter housing. Install the primary turbo oil feed line (1453130-B) from the JIC fitting you installed earlier in the filter housing to the JICM fitting on the primary turbo, the line should run between the turbo and engine.

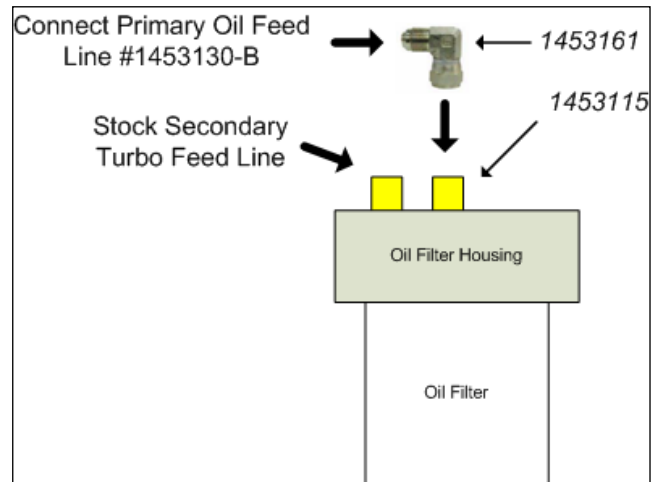

62. Remove the factory intercooler tube and boot from the factory intercooler pipe and place them on the new intercooler pipe provided.

63. Install the cast aluminum elbow and intercooler tube assembly to the compressor outlet of the secondary turbo and the lower intercooler boot. Secure with the factory v-band clamp and the two boot band clamps (use a 7/16" deep socket to tighten all clamps).

Do not forget to re-install the orange o-ring in the cast aluminum elbow before connecting the elbow to the compressor housing. You can now install the intercooler tube in place to the elbow and the intercooler.

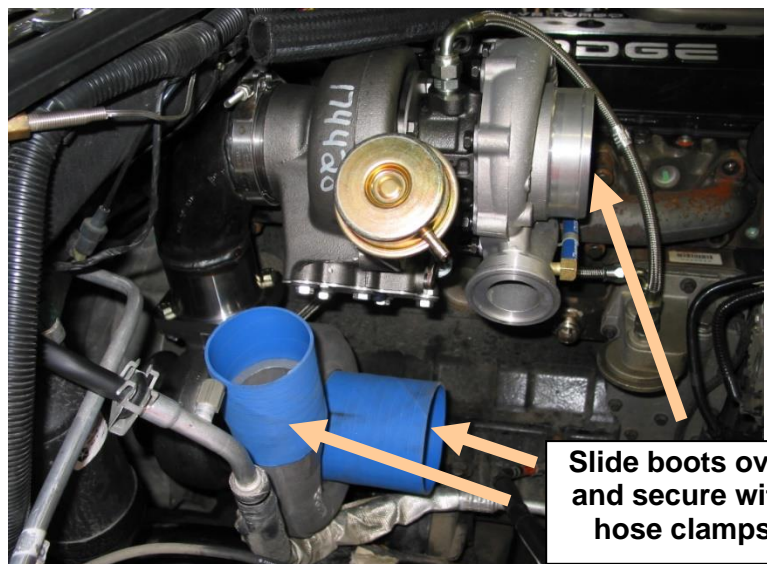

64. The compressor housing of the primary turbo should still be loose and so adjustments can be made as required. Move the compressor housing around

so that the fit is secure and the tubes will not hit anything when the engine torques over.

65. Install a 4 inch silicone boot on both the primary turbo and secondary turbo compressor housing inlets – also slide two Heavy Duty 4” band clamps on to each boot for easier installation later.

66. Install a 3” silicone boot on the compressor outlet of the primary turbo and slide two Heavy Duty 3” band clamps onto the boot.

67. Slide the 90-degree steel pipe into the compressor outlet boot on the primary turbo and point the pipe outlet towards the front of the vehicle.



68. Install a 3” silicone boot on the 3” ‘U’ 180° pipe and slide two Heavy Duty 3” band clamps onto the boot and install it between the short 90° on the primary to the secondary turbo 4” inlet.

69. Once all intermediate pipes are lined up, the heavy-duty hose clamps can be tightened as well as the bolts on the primary turbo compressor housing.

70. Loosely secure the new down pipe to the primary turbo using the supplied V-band clamp.

Note that you will have to massage the firewall to allow enough clearance for the down pipe.

Be sure to align all exhaust pipes, and then tighten the V band clamp on the back of the turbo. Once this is done you can finally clamp and weld the appropriate exhaust components.

71. Wrap the turbine housing blanket around the turbo housing, then secure by attaching the springs.

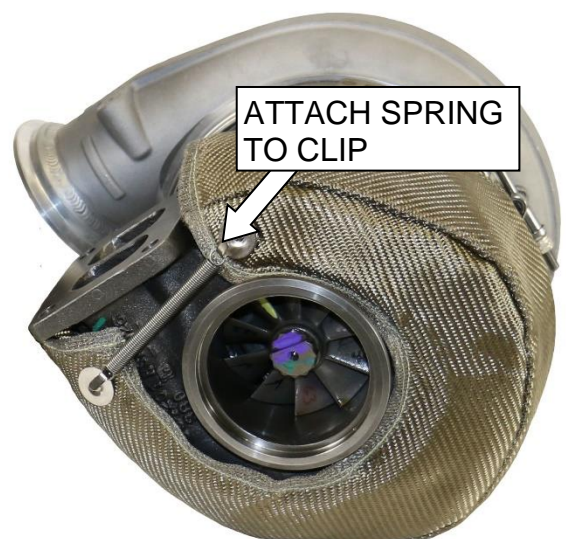

72. Install the air box spacer on the stud at the front closest to the engine. This stud is lower than the other two.

73. Insert the 4" intake tube into the air box and then into the silicone boot in the compressor-housing inlet of the primary turbo. Install air box onto the factory studs using the three supplied 1/4" NF nuts and the three supplied 1/4" flat washers.

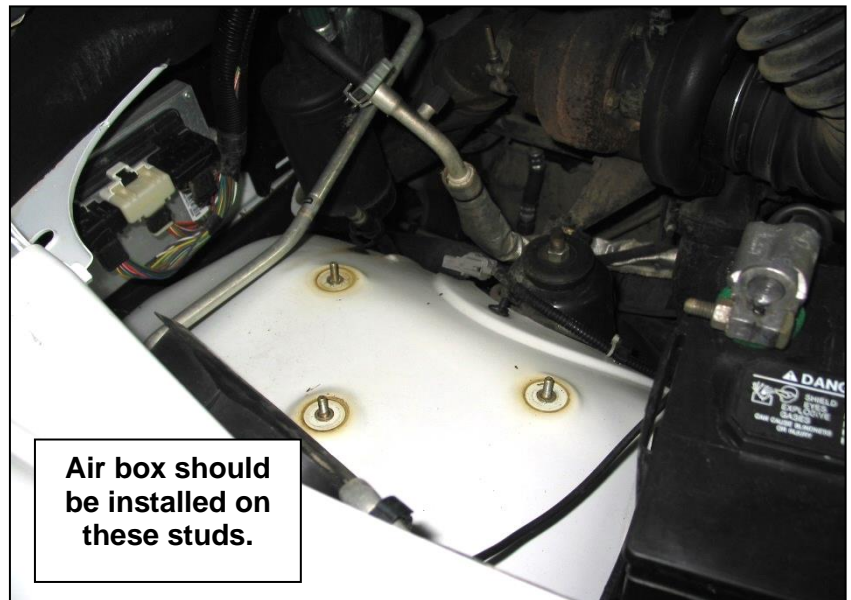

74. Using a 7/16 deep socket tighten the two band clamps on the silicone boots – ensure all pipes have good contact with the boots and at least 1/8" of boot sticks out past each clamp.

75. Install the supplied air filter by inserting it onto the pipe after it has passed through the air box and secure it with the supplied 4" hose clamp.

76. Re-connect the battery terminals and refill engine coolant. Double check all connections to make sure that they are all secure and free from any damage. You now may start the vehicle, once the vehicle has start and is up to temperature re-check for leaks and ensure that all the air is out of the coolant system.



Note: The exhaust housings of the turbos may smoke slightly when new, as manufacturing residue on housing must burn off.

Twin Turbo Testing

It is highly recommended that allow the turbochargers to break in before any high power test runs. You may have to adjust the waste gate with shims or a bleed orifice to ensure this boost level. Maximum boost will be determined by maximum turbo wheel speed, which will vary depending on supporting modifications and RPM.

Primary Turbocharger	Approximate Maximum Boost
S366	55
S472 SXE	65
S476 SXE	75

While driving listen for any odd noises such as a boost leak or perhaps piping rubbing against the vehicle. Once the vehicle has gone through a number of heat cycles it is highly suggested to retighten all clamps, bolts and nuts.

Periodically retighten all clamps and check for any oil or boost leaks.

IMPORTANT When idled for any length of time some oil may leak from the turbo. If the performance/boost is satisfactory and the wheel is not touching the housing (There will be some small movement), the excess oil is not a concern. Simply wipe with a clean cotton cloth and continue use.

Wastegate Adjustments

This turbocharger may be used in both single and twin applications, and as such will need its default wastegate setting raised. BD recommends adjusting this wastegate to achieve maximum boost pressures possible, and lowering engine fueling to control boost pressure. This may be done electronically with a tuner or plug in module, or mechanically. Setting the wastegate too low will overwork the primary turbocharger and will reduce efficiency, raising EGTs and lowering fuel economy.

To adjust the wastegate, loosen the jam nut on the actuator rod, and turn the actuator rod adapter. Once the new setting is made, tighten the jam nut to keep the rod adapter from moving. To increase boost pressure, turn the rod adapter clockwise to shorten the distance from the actuator. To lower boost pressure, turn the actuator rod adapter counter-clockwise to lengthen the distance from the actuator.

If you have questions, please contact BD's technical support department.

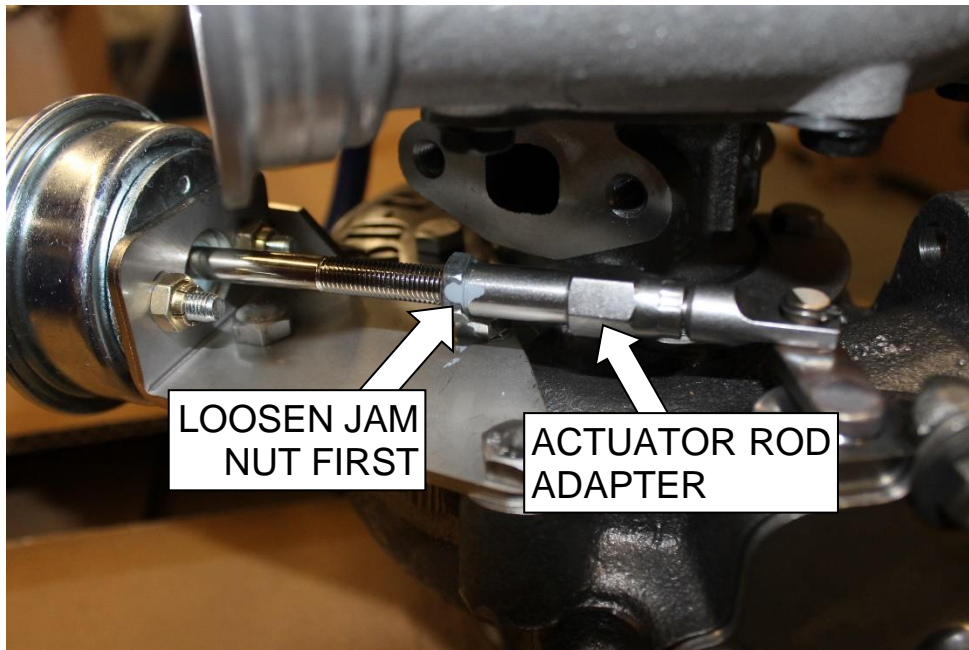

BD WILL NOT BE RESPONSIBLE FOR ANY FAILURES OF THE VEHICLE'S HEAD GASKET.