

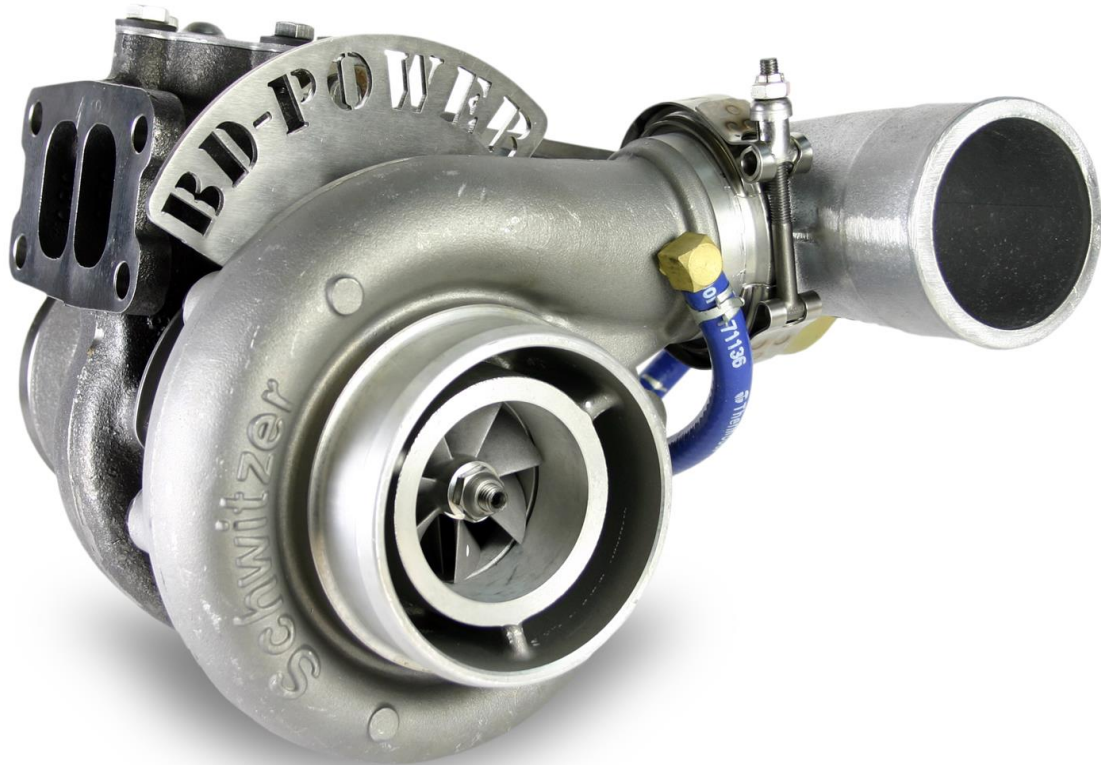

*DOWNLOAD THE
LATEST INSTALL*



BD Super "B" Single

2004½-2007 Dodge 5.9L Cummins 24v ISBe
(600 motors only)

Part # 1045235

PLEASE READ ALL INSTRUCTIONS BEFORE INSTALLATION.

Note: This turbo system is not compatible with an AFE intake system **WITHOUT MODIFICATION.**

UNLESS AN EO# IS LISTED, THIS PRODUCT IS LEGAL IN CALIFORNIA FOR RACING VEHICLES ONLY, WHICH MAY NEVER BE USED UPON A HIGHWAY.

Kit Contents

Please check to make sure that you have all the parts listed in this kit **before** you start the disassembly of your truck.

DODGE 2004½ - 2007 "SUPER B" SINGLE TURBO KIT (BD# 1045235)					
1405219	1452225	1453251	1040142		
					
<i>Super "B" Single Turbo</i>	<i>V-Band Clamp</i>	<i>Elbow O-Ring</i>	<i>Exhaust Pipe Heat Wrap</i>		
Qty: 1	Qty: 1	Qty: 1	Qty: 1		
1040145	1453240	1405926	1453255		
					
<i>Heat Wrap Wire (ft)</i>	<i>Wastegate Follower</i>	<i>Downpipe V-Band Clamp</i>	<i>Turbo Down Pipe</i>		
Qty: 4'	Qty: 1	Qty: 1	Qty: 1		
1452811	1452812	1452813	1452822	1452814	1452815
					
<i>Bolt - 10mm x 1 ½ x 20mm</i>	<i>Bolt - 10mm x 1 ½ x 30mm</i>	<i>Bolt - 3/8"NF x 1 ¾"</i>	<i>Bolt – 3/8" NF x 1 ½"</i>	<i>3/8"NF Nut</i>	<i>3/8" Washer</i>
Qty: 1	Qty: 1	Qty: 2	Qty: 2	Qty: 2	Qty: 6
1452226		1100740			
					
<i>Outlet Elbow</i>		<i>Exhaust Seal Clamp</i>			
Qty: 1		Qty: 1			

Required Tools

Wrenches : 9/16", 13mm, 15mm, 17mm, 19mm, 21mm

Sockets : 5/16", 7/16", 9/16", 7mm, 10mm, 11mm

Installation Notes

A turbocharger is driven solely on exhaust energy. Therefore, if the vehicles current exhaust manifold is cracked or is leaking, it is recommend that new exhaust gaskets and a heavy-duty exhaust manifold be used.

Installation should occur on a cold vehicle, as turbo and exhaust components become very hot with use.

The BD turbo system is recommended for trucks with 300-400 RWHP with a maximum efficient boost pressure of 45psi.

It is highly recommended that when installing this turbo, that our high performance two-piece manifold be installed at the same time. This new manifold utilizes pulse technology/duel volute to spool the turbo faster than the stock single volute manifold. As well this manifold can handle much higher temperatures than the stock one.

Manifold part # 1045987

If you are installing a BD Engine Brake with this turbo you will require:

(1) Turbo Plate PN# 1453238

(5) M8-1.25 x 20mm bolts

Reuse the existing (5) hardened M8 washers.

Upgrade Options

Description	Part#
BD "X" Torque Convertor	1070217X
BD HD Transmission	CALL
BD High Flow Injectors	CALL
BD FlowMAX Auxiliary Lift Pump Kit	1050310
BD HD Exhaust Manifold	1045977
BD X-Monitor	1085220
BD Twin Turbo Upgrade Kit	1045335
BD Cool Down Timer ²	1081160

Battery Disconnect

Record preset radio settings (if desired). Disconnect the negative terminals on both of the vehicle's batteries, and then disconnect the positive terminals.

Installation

Disconnect the airflow sensor and intake tube 5/16". Remove the air box with a 10mm socket.

Remove the passenger side inner fender well with a 21mm socket, for easier access to engine parts.

Remove the turbo oil feed line with a 13/16" wrench and the oil drain line with a 10mm socket. Pull the oil drain tube out of the engine block.

Remove the passenger side intercooler hose band clamps with a 7/16" deep socket. Remove the intercooler tube from the engine compartment.

Remove the factory cast exhaust elbow or turbo mount brake using a 7/16" deep socket for the upper V-band clamp and a 10mm deep socket for the lower/rear V-band clamp.

You will need to disconnect the plug for the electronic wastegate actuator. At this time you can install the male wastegate fooler plug that is supplied with this kit (see the kit contents page if unsure). Insert the wastegate fooler into the female factory wiring harness and secure with a zip tie away from anything that has moving parts or from parts that are hot. Turbo and exhaust manifold can be removed as an assembly if desired. This allows easier access to turbo mounting hardware.

Remove the four nuts holding the turbo to the exhaust manifold with a 15mm wrench. With the turbo unbolted from the manifold, carefully lift it out of the engine and set it aside. **Remove the two studs from the factory manifold.**

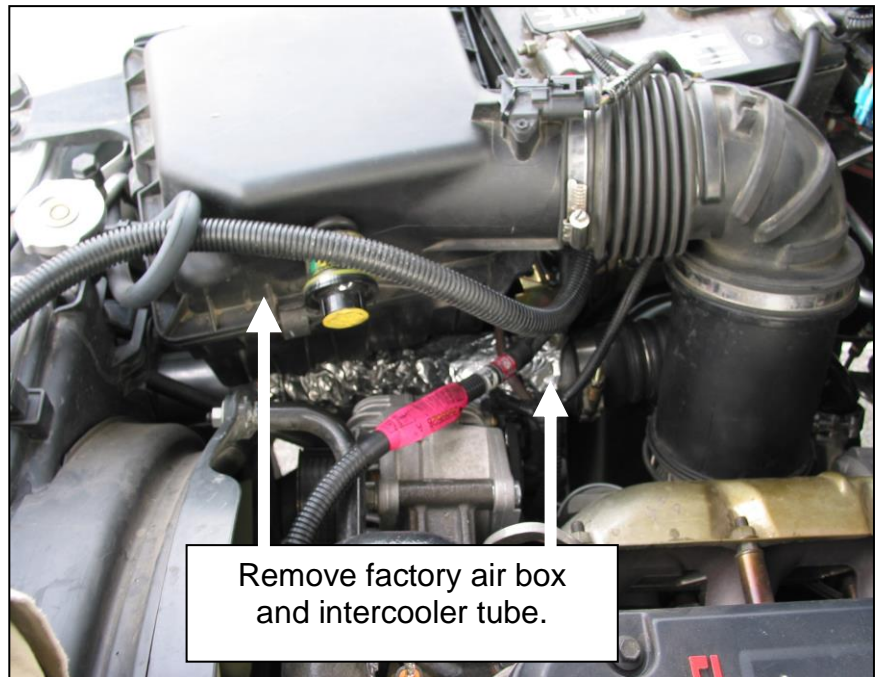

Remove factory air box
and intercooler tube.

Carefully lower the **Super 'B'** into place, making sure there is a $\frac{1}{4}$ " gap between the waste gate actuator and the cast engine mount. Most trucks will have sufficient room, but due to casting tolerances you may have grind the engine mount slightly.

Mount the **Super 'B'** turbo and new gasket into place using the metric 10mm bolts into the threaded holes in the manifold (shorter bolt to the rear of the engine). With offset 17mm wrench.

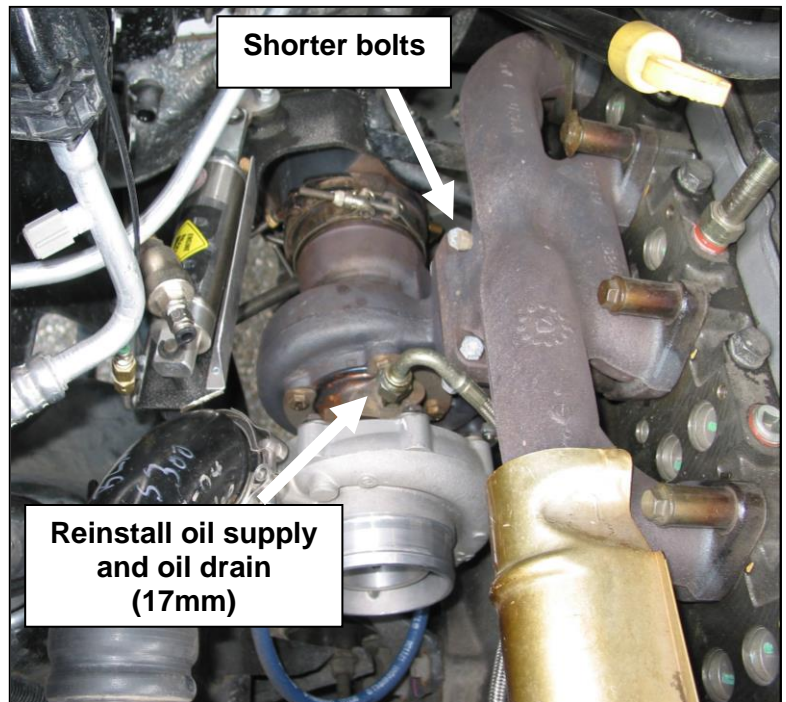

Installing turbo with Stock Manifold

Mount the **Super 'B' Special** turbo and new gaskets in place using the metric 10mm bolts into the threaded holes in the manifold (shorter bolt to the rear of the engine). If you are mounting the turbo to a stock manifold you will require the supplied **$\frac{3}{8}$ " x $1\frac{3}{4}$ "** bolts for the unthreaded holes. These bolts should be inserted from the manifold side and fastened to the turbine housing using the supplied washers and nuts. Use an offset 17mm wrench to accommodate tightening of the inner bolts and two $\frac{9}{16}$ " for the outer bolts and torque turbo to manifold bolts to 32 ft/lbs.

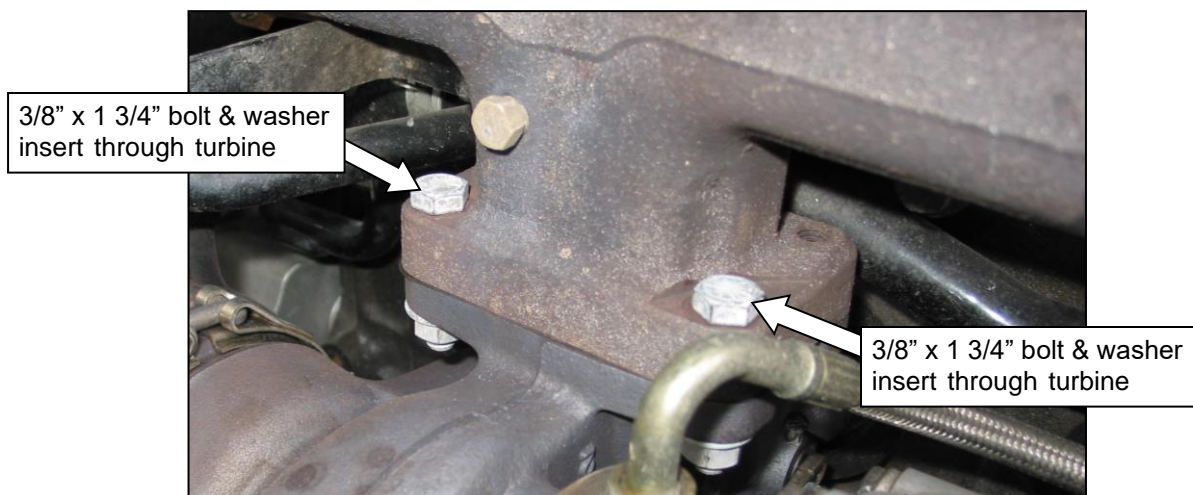

Installing turbo with BD Manifold

Mount the **Super 'B' Special** turbo and new gaskets in place using the metric 10mm bolts into the threaded holes in the manifold (shorter bolt to the rear of the engine). If you are mounting the turbo to a BD manifold you will require the supplied **3/8" x 1 1/2"** bolts for the unthreaded holes. One bolt will need to be inserted from the manifold side and the other will need to be inserted from the turbine side (see diagram for details) and fastened using the supplied washers and nuts. Use an offset 17mm wrench to accommodate tightening of the inner bolts and two 9/16" for the outer bolts and torque turbo to manifold bolts to 32 ft/lbs.

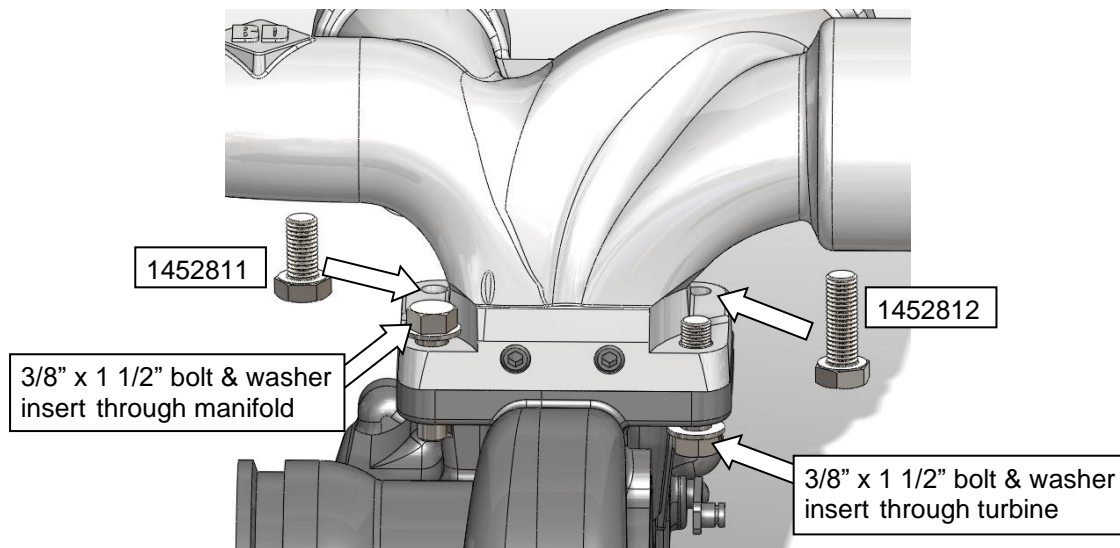

Turbo Clocking / Aligning (If Necessary)

Loosen the four bolts clamping the exhaust housing to the turbo body and rotate body until oil feed drains are straight up and down. Re-tighten the four bolts. Loosen the eight bolts clamping the turbo compressor housing to the body and rotate housing to align with intercooler tube. You need to align the compressor outlet adapter to the intercooler tube. Now tighten the eight bolts holding the compressor housing to the body to secure its position.

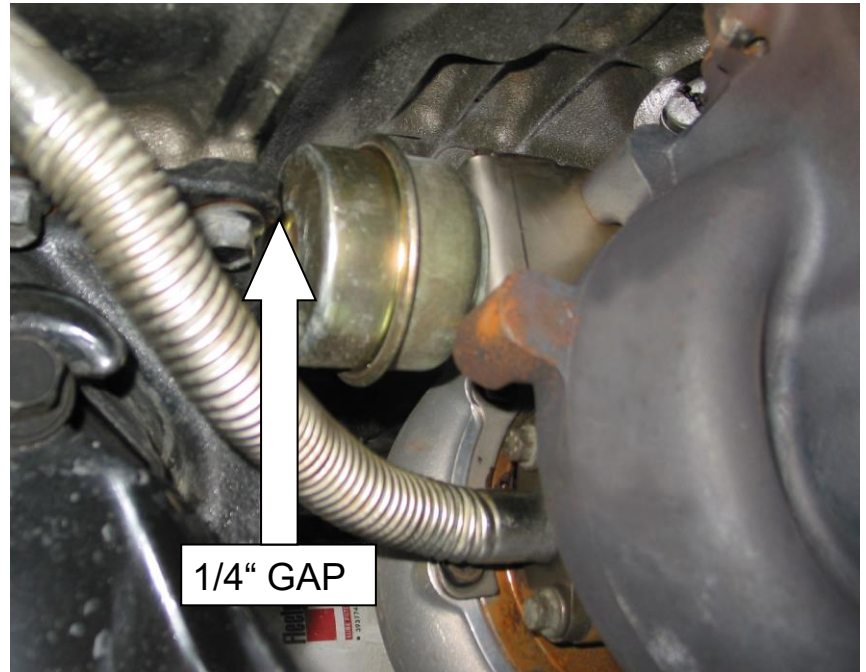

Once everything is tight, double check the waste gate actuator clearance to make sure you have ¼” to the cast engine mount.

Install the powder coated compressor outlet elbow, o-ring, and V-band clamp.

At this time you may insert the intercooler tube that you removed earlier. Don't forget to clean and secure all intercooler boots and tighten the hose clamps. When re-installing the intercooler tube, rotate the tube so that it is clear and free from either the air box or the plastic inlet tube. As well be careful that the compressor outlet elbow does not contact the shock tower.



Install the supplied exhaust down pipe and V-band clamp to the back of the **Super 'B'** turbo. You will most likely have to move the exhaust around a bit to make everything match up correctly. Once everything fits properly, use the supplied 4” stainless steel

clamp to secure the down pipe to your exhaust.

Re-install the turbo oil drain into the block and to the bottom of the turbo with a new gasket before pre-oiling the turbo. Squirt liberal amounts of fresh 15W40 diesel oil into the new turbo while spinning the compressor wheel. Re-install the oil supply line to the top of the turbo.

Re-install the plastic fender well liner, followed by the air box and tube. Note that unless you have a high flow Stainless **BD X-intake system**, the heat wrap should be used to insulate the factory plastic air box from the intercooler tube. You can use the provided stainless wire to secure the wrap.

Reconnect the negative battery terminals and start the vehicle. **Check for any exhaust or oil leaks.**

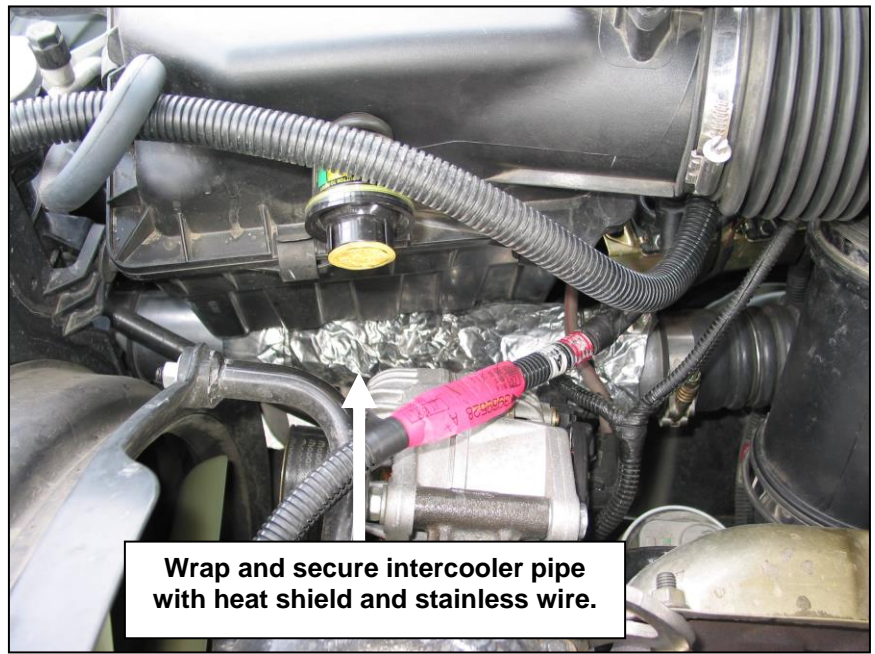

Take it easy on the turbo for the first 100 miles to allow a proper break-in period. Be very cautious of any unusual sounds or leaks during this time. **Make sure that all clamps and connections are tight.**

Note: The exhaust housing of the new turbo may smoke as there may be some manufacturing residue on the housing that must burn off.

Also take care when shutting the vehicle down that you do not shut the vehicle down when it's still hot (>400°). This will cause oil coking and will damage the turbo. The **BD Cool Down Timer** can automate this process for you.

IMPORTANT When idled for any length of time some oil may leak from the turbo. If the performance/boost is satisfactory and the wheel is not touching the housing (There will be some small movement), the excess oil is not a concern. Simply wipe with a clean cotton cloth and continue use.

Questions?

If you have questions, comments, complaints or general technical questions regarding this product, then please call our Technical Support hotline at (800) 887-5030 – Monday to Friday, 8:30am to 5:00pm, Pacific Standard Time (PST).

Or, as an alternative, you can post a message on our technical bulletin board, located on the internet at <http://bd-power.com/forum>.

Addendum A

In late model 5.9L (approx 2005-2006) years Chrysler changed the location of the transmission dip stick. Because of this you will need to cut and re weld the dipstick bracket in a new position to clear the downpipe. Some forgiving messaging with a ball peen hammer will free up just enough room to ensure no contact between the dipstick and downpipe.



