



**DOWNLOAD THE LATEST
INSTALL MANUALS AT
www.bddiesel.com**



GMC/CHEVY LB7/LLY DURAMAX (01-05)

COOL-IT INTERCOOLER

Installation Instructions



P/N# 1042600



PLEASE READ ALL INSTRUCTIONS BEFORE INSTALLATION

UNLESS AN EO# IS LISTED, THIS PRODUCT IS LEGAL IN CALIFORNIA FOR RACING VEHICLES ONLY, WHICH MAY NEVER BE USED UPON A HIGHWAY.

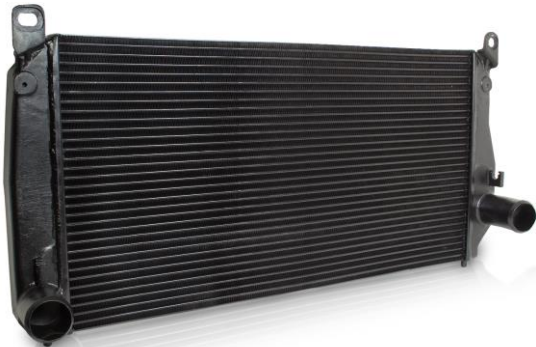
KIT CONTENTS:

Please check to make sure that you have all the parts listed in this kit **before** you start the disassembly of your truck.

1402605	1402606	1402609
		
<i>Intercooler</i>	<i>Spacer</i>	<i>Washer, M8 x 24mm</i>
Qty: 1	Qty: 1	Qty: 2

1402608	1402607	1100035
		
<i>Washer M6 x 18mm</i>	<i>Bolt, M6 x 55mm</i>	<i>Bolt, M8 x 35mm</i>
Qty: 4	Qty: 4	Qty: 2

Options

<u>Description</u>	<u>Part #</u>
Super Max Turbo Kit 2001-04 LB7	1046200
Super Max Turbo Kit 2004½-05 LLY	1046210

Removal

Remove radio presets and disconnect the negative terminals of both batteries.

Remove the 7 radiator closure panel fasteners by popping the center pin up with a slotted screwdriver.



Remove the headlights by pulling the mounting pins to detach them from the mounting panel.



The marker lights have one clip on the outside which is released by pulling the outer corner of the light straight forward, keep pulling the outside of the light forward and the inside tab will disengage.





Remove the 1 bolt holding the grille to the upper tie bar with a 10mm socket. Use a clip removal or similar tool to release these clips shown here, and the far outer clips can be removed by pulling them out by hand.



Remove the two headlight mounting panels. There are 6 - 10mm and 2 - T25 Torx.

Note the position of the Torx as they need to go back in the same place for headlight clearance.



Remove your air filter box.



Under your air box there is a metal support bracket to remove. Loosen it but do not remove the two 10mm bolts that hold it to the radiator support. Remove one that holds the coolant reservoir to the bracket.



With a 10mm socket, remove the three hood latch bolts (The position is critical, mark where it lines up to the tie bar with a paint pen).

With a 10mm socket, remove the 4 bolts from the transmission cooler, and the 2 bolts from the condenser.



Remove the support strut from the driver's side fender to the tie bar.

You can remove the tie bar end bolt and swing it out of the way, leaving it attached to the fender.



Remove the upper fan shroud. There are 2 push fasteners on each side holding it to the lower shroud and 4 - 10mm head bolts across the top to the tie bar.



Remove the 2 brackets that secure the bottom of the radiator to the CAC. Unbolt the radiator from the CAC, followed by the 2 bolts that secure the CAC to the upper tie bar with a 13mm socket.



Remove the upper tie bar with a 10mm socket. There are 3 on each end coming up from the bottom and 2 on each side on the lower struts.



Loosen the boot clamps with a 7/16 deep socket on both the driver's and passenger side.

Clean your boots with a good brake cleaner (that doesn't leave a residue) and swap over the 4 rubber grommets to the new BD intercooler - 2 on the top and 2 on the bottom.



You will need two people for this part to avoid damaging any fins. Pull the condenser and transmission cooler forward, lift the radiator up out of the grommets on the CAC and push it back, then carefully remove the CAC.

Installation

With two people, put the new BD CAC unit in place and re-install the boot clamps with a 7/16" deep socket on both sides.



Install the upper tie bar with a 10mm socket. There are 3 on each end coming up from the bottom and 2 on each side on the lower struts.

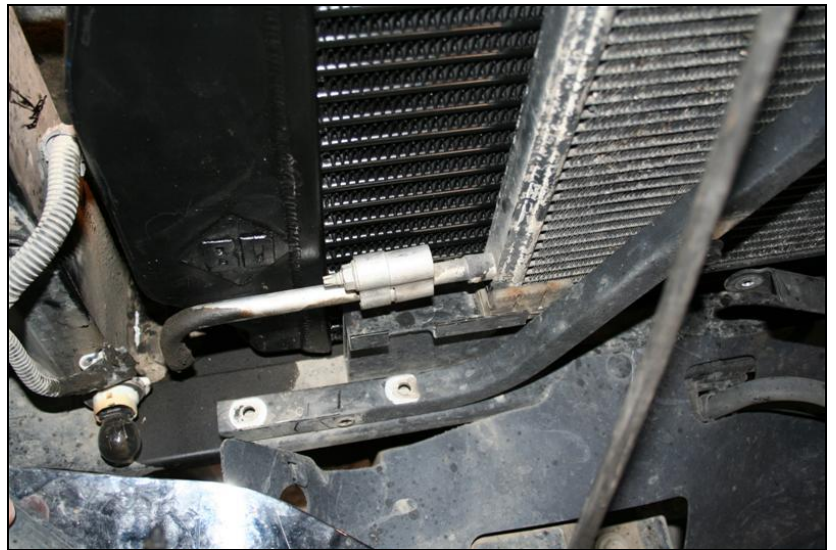

Bolt the radiator to the CAC. Use the

2 new M8 x 35mm bolts (**1100035**) and M8 washers (**1462609**) supplied and bolt the CAC to the upper tie bar.



Install the upper fan shroud with the 2 push fasteners per side, holding it to the lower shroud.

Install the supplied long spacer between the shroud and upper tie bar with the 4 new M6 x 55 mm (**1402607**) supplied bolts and the 4 M6 washers (**1462608**).

The four cutouts/reliefs should face towards the front of the truck.

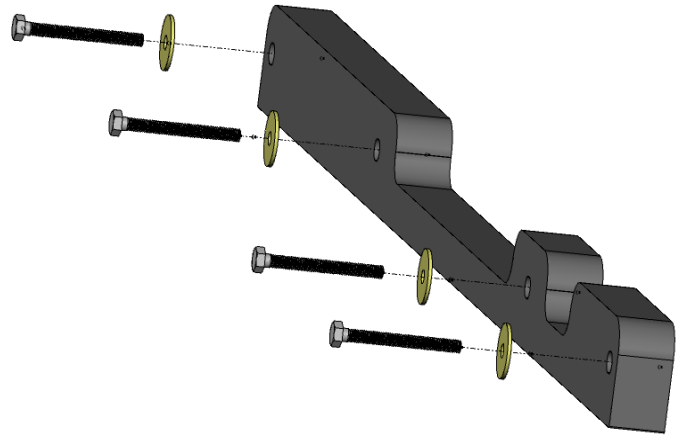

With a 10mm socket, install the hood latch with the 3 bolts taken off earlier (The position is critical, make sure it lines up to the tie bar paint pen marks).

With a 10mm socket, install the transmission cooler (4 bolts), and the condenser (2 bolts).



Install the driver's side support strut to the tie bar with a 10mm socket.

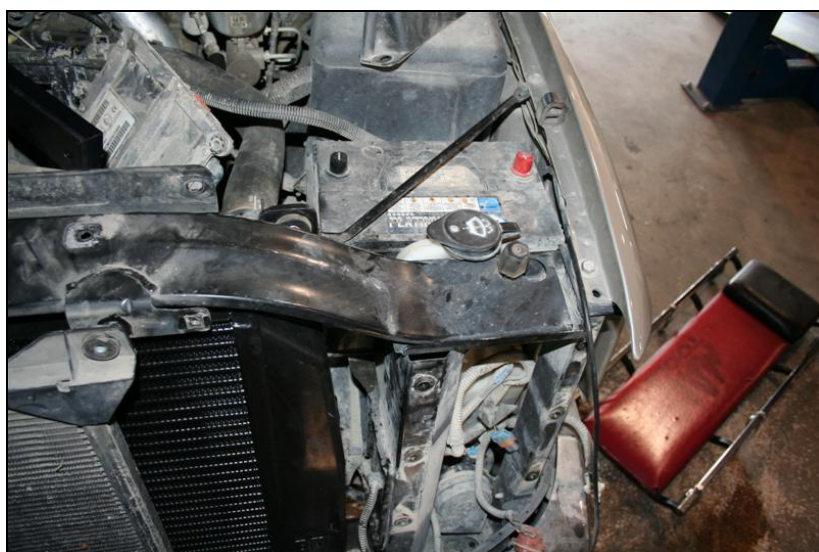

While you can still clearly see the hood latch, bring down the hood to make sure the latch will line up, and if it does, do a test by closing it before continuing.



The bracket that supports the air box will need to be modified as shown, and then painted for corrosion resistance.



Install the metal support bracket onto the loosened bolts still in the radiator support, tighten them and install the one that holds the coolant reservoir to the bracket with a 10mm socket.



Re-install your air box or replace it with a BD X-Intake.

Install the two headlight mounting panels with the 6 - 10mm and 2 - T25 Torx. Make sure to put the 2 Torx in the same place they came out for proper headlight clearance.



Install the grille by pushing all the clips into the receivers and the 1 bolt in holding the grille to the upper tie bar with a 10mm socket.





Install the marker lights by tucking in the inside tab first, and then push the outer clip into the headlight panel.

Place the headlights in place and insert the mounting pins.



Install the radiator closure panel with the 7 push fasteners.



Reconnect both negative battery terminals, and reprogram the radio.