

NOTE: It is important that all the areas where the bed cover mounts to the truck are clean and free of debris before installation.

TOOLS REQUIRED

- Scissors or utility knife
- Isopropyl alcohol
- 1/2" Wrench or socket
- Phillips screwdriver
- 5/8" Drill bit & drill

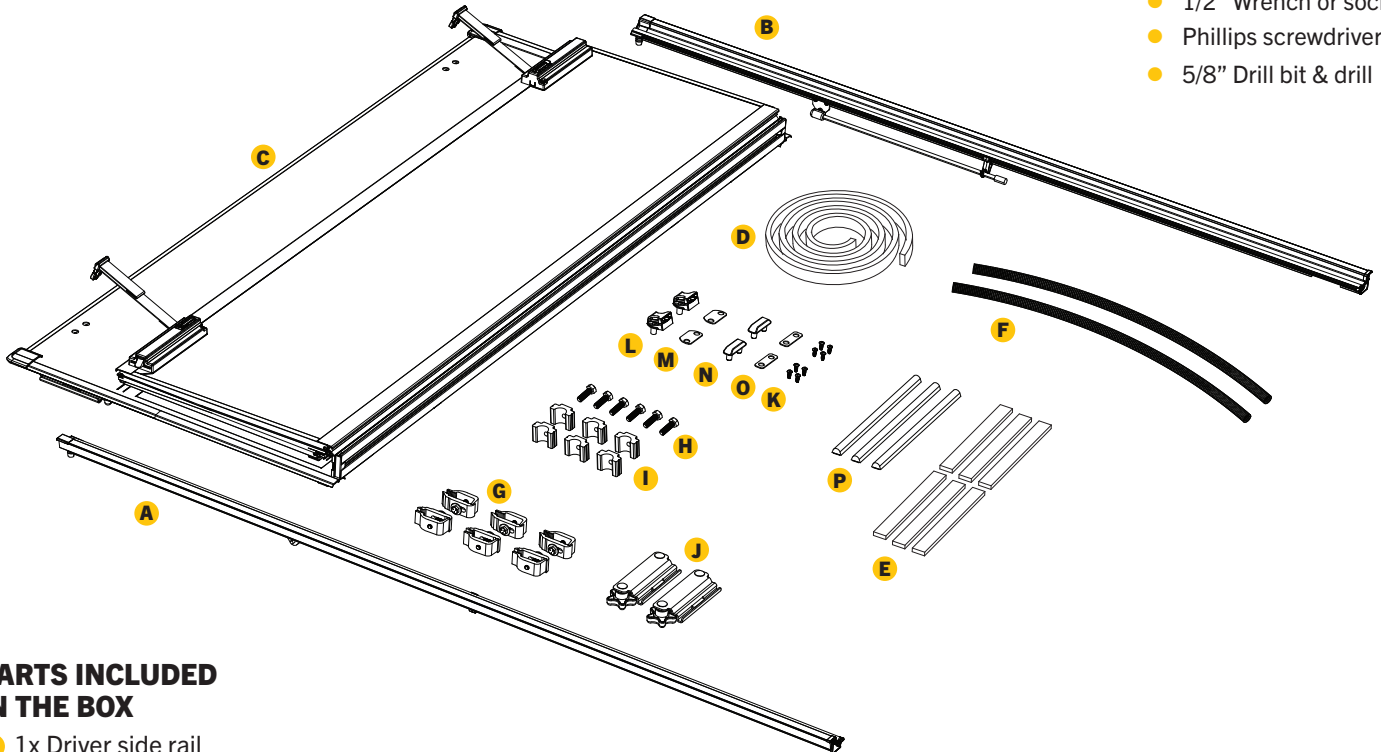

**PARTS INCLUDED
 IN THE BOX**

- A** 1x Driver side rail
- B** 1x Passenger side rail
- C** 1x Hard fold cover
- D** 1x Bulkhead seal
(on select make/models)
- E** 6-8x Rubber filler strips
(on select make/models)
- F** 2x Drain tubes
- G** 6x Clamps
- H** 6x Bolts
- I** 6x T-nuts
- J** 2x Cover retainer clamps
- K** 8x Screws
- L** 2x Buckle ends
- M** 2x Buckle end gaskets
- N** 2x Wedge stops
(on select make/models)
- O** 2x Wedge stop gaskets
(on select make/models)
- P** 3x D-shaped cab bumpers
(on select make/models)

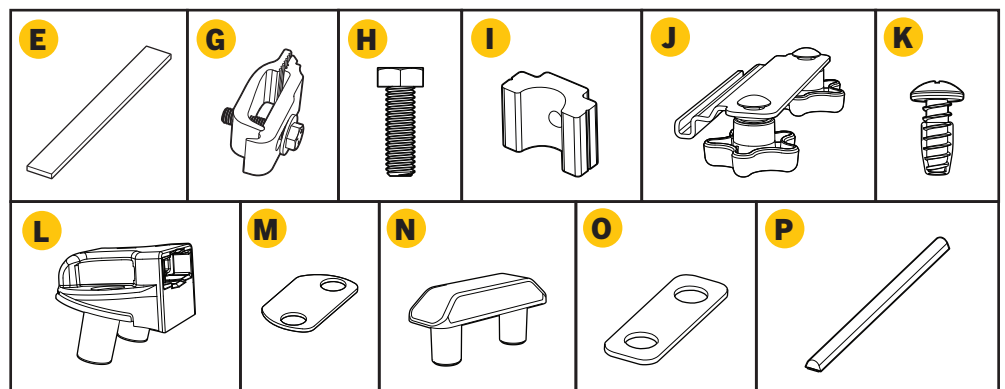

! IMPORTANT

READ BEFORE YOU BEGIN INSTALLATION

IT IS CRITICAL FOR YOUR SAFETY THAT YOU CAREFULLY READ AND FOLLOW THE SAFETY CAUTIONS AND INSTALLATION INSTRUCTIONS BOTH PRIOR TO AND DURING INSTALLATION.

USER SAFETY CAUTION

During installation, be mindful of the potential for sharp edges on the product or vehicle. Taking proper safety precautions helps ensure a safe and smooth installation process.



Always wear protective gloves and handle components with care to reduce the risk of injury.

TEMPERATURE SURFACE CAUTION

During high temperatures or extended sun exposure, surfaces of this product may become hot to the touch, posing a risk of burns or injury. Use caution when handling the product in hot weather and allow time for it to cool before contact.



Always check surface temperature before use to ensure safe handling conditions.

FASTENER TORQUE CAUTION

All fasteners must be tightened to the specified torque values provided in the installation instructions to ensure proper fit and safe operation of the tonneau cover. Under- or over-tightening can lead to product failure, potential damage to your vehicle, injury, or safety hazards while driving.

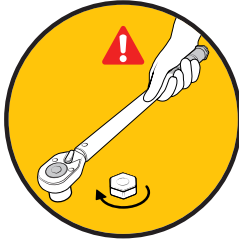

Always use a calibrated torque wrench and follow the specifications in the installation instructions.

PINCH POINT SAFETY CAUTION

This tonneau cover may create pinch points when closing or operating near solid surfaces such as the truck bed rails or tailgate. To prevent injury, keep hands, fingers, and other body parts clear of moving parts during operation.



Always operate the cover slowly and with caution to ensure safe and proper use.

ENTRAPMENT SAFETY WARNING

This tonneau cover does not feature a manual release mechanism from inside the truck bed. To prevent the risk of entrapment, never allow anyone to be inside the bed of the truck when the cover is closed.

Always ensure the area is clear before closing the cover, and keep the cover securely latched when not in use to avoid accidental closure.

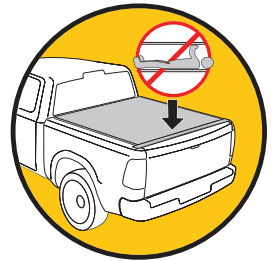

CARGO TRANSPORT WARNING

Do not attempt to close the tonneau cover over cargo that is taller than the depth of the truck bed.

Never force the cover to close improperly.

Forcing the cover can:

- Prevent the cover from lying flat and latching securely.
- Damage the cover's hinge and cause the cover to kink.
- Damage the rear tail panel and cause it to become detached.



INSTALLATION STEPS

- 1** If a bulkhead seal (D) was NOT included in your kit, skip to step 2. If you received a bulkhead seal with the cover (C), clean the top of the bulkhead with soap and water to remove dirt and debris. Clean the area with isopropyl alcohol to remove wax or grease and to evaporate any remaining water. Allow the surface to dry. Peel the backing and adhere the seal from one bulkhead edge to the other. Remove any excess with Scissors or a utility knife. Apply pressure evenly to the entire seal to ensure proper adhesion. If the truck has a drop-in bedliner, no seal will be needed.

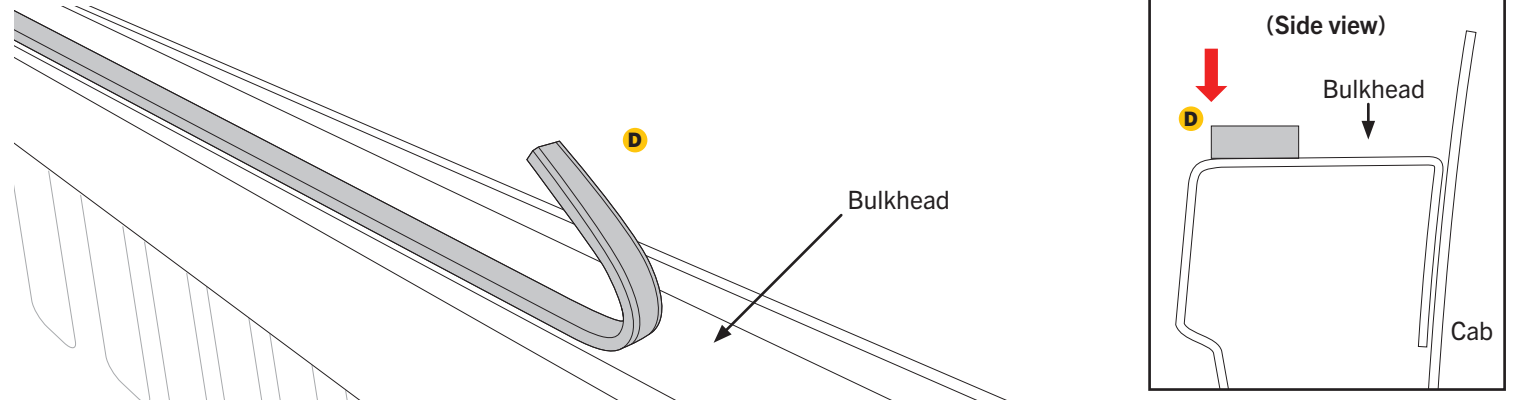

- 2** If rubber filler strips (E) were NOT included in your kit, skip to step 3. If you received rubber filler strips (E) with the cover (C), clean the rail the same way as you did in step 1. Peel the backing and adhere the filler strips (E), as illustrated, between the truck plastic bed cap and truck metal rail. Place one 6-8 inches from the bulkhead. Place the rear strip as close to the tailgate as possible. Center the middle strip appropriately.

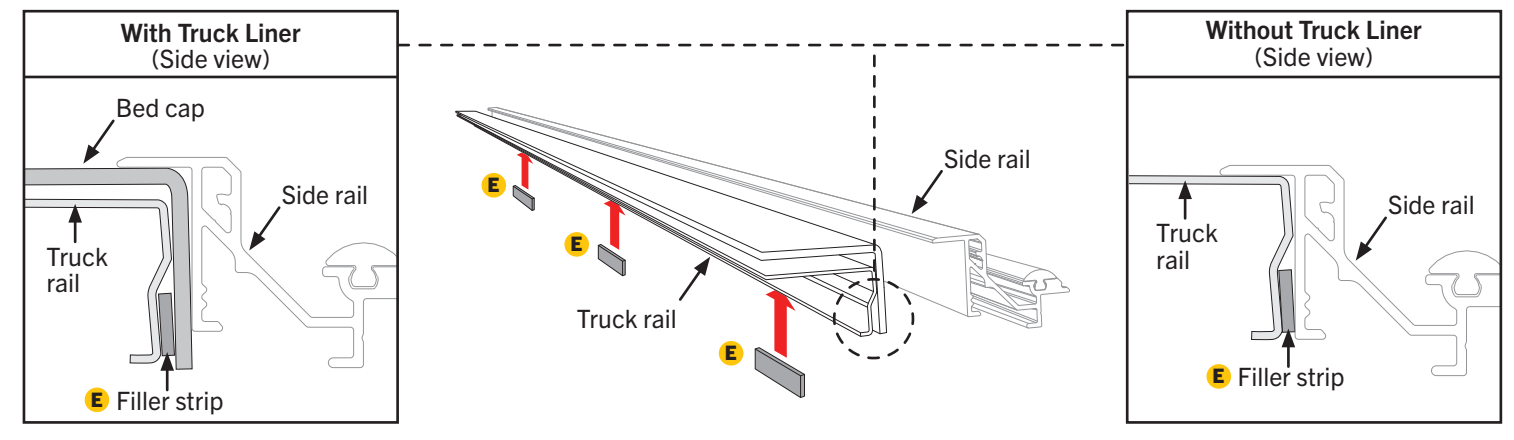

- 3** Attach the drain tubes (F) to the front of the side rails (A & B) to allow water to be diverted out of the truck bed via the rail. The opposite end of the drain tubes can be placed behind a bedliner, through the bed plugs, or by drilling a 5/8" hole in the bulkhead.

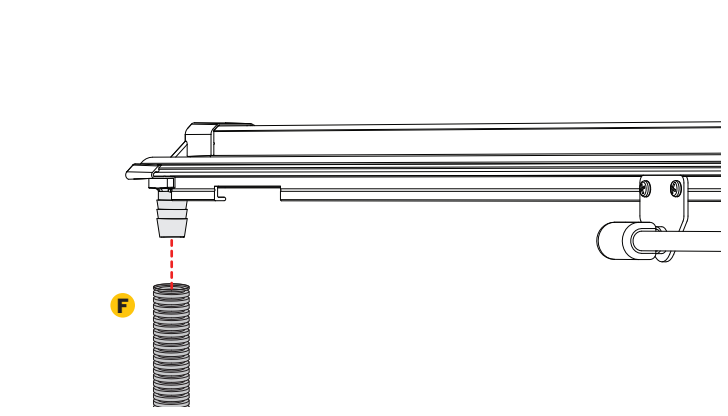

- 4** Place the passenger side rail (B) on the truck rail. Position the side rail flush with the top edge of your truck bed rail. The end of the side rail with the drain tube will go towards the cab of the truck.

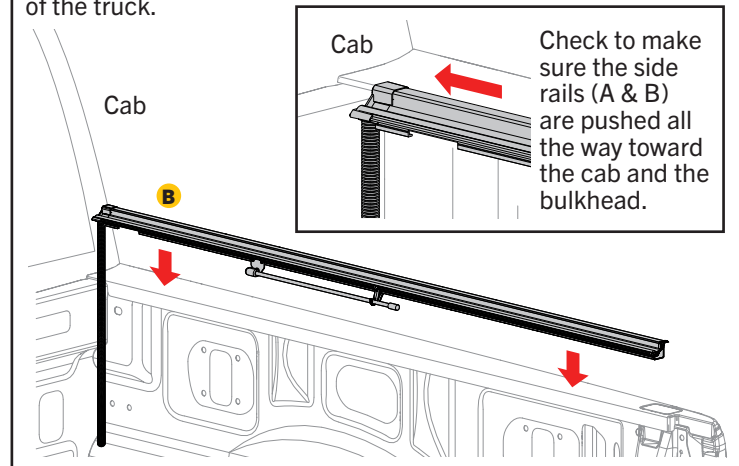

5a If your truck bed does NOT have the Utili-Track System, skip to step 5b. Disassemble clamps (G). Set aside washers. Snap three front halves of clamps (G) into the tapered portion of the passenger side rail (B). Snap one half clamp (G) as close to the tailgate as possible within 12" from the tailgate. Snap the second half clamp (G) at the center of the side rail. Snap the third half clamp (G) as close to the end of the side rail on the cab side as possible within 12" from the cab/bulkhead.

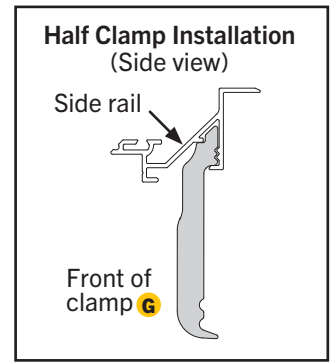
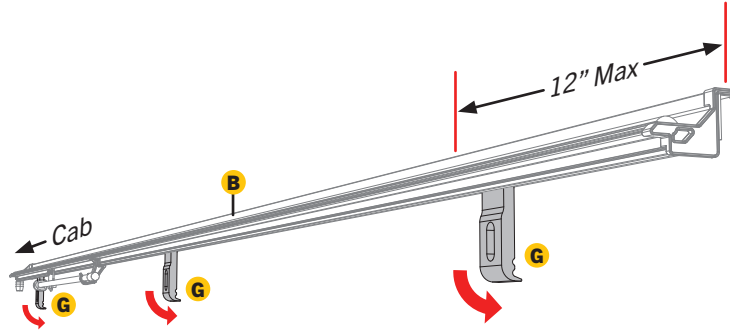
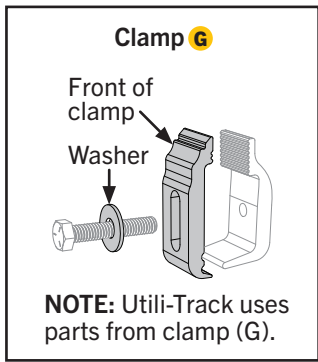

Make sure the side rail is pushed up against the cab/bulkhead. Insert three t-nuts (I) into the tailgate end of the Utili-Track. Align one t-nut (I) to each clamp half (G). Secure each half clamp to one t-nut (I) with a washer (G) and bolt (H). Tighten all clamps to **10 ft-lbs. (14 Nm)** of torque using a 1/2" wrench or socket **CAUTION: Do not overtighten!** ⚠️

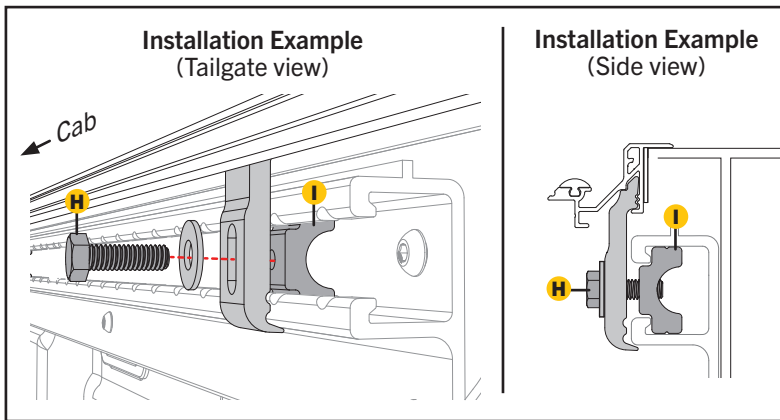
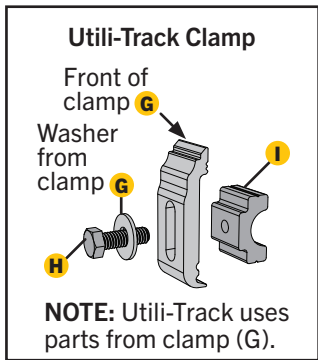

TIP: If the rails are leaning down, have one person stand on the outside of the bed and slightly roll the rails upward while another person slowly snugs the clamps up. If the clamps are tightened too quickly or overtightened, it will cause the rails to lean down.

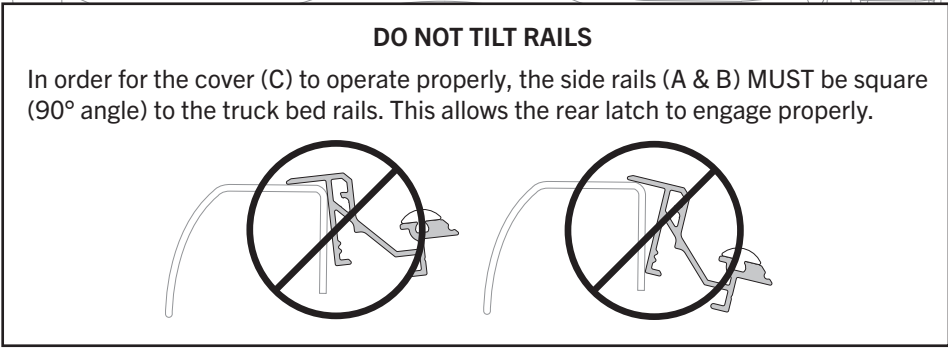
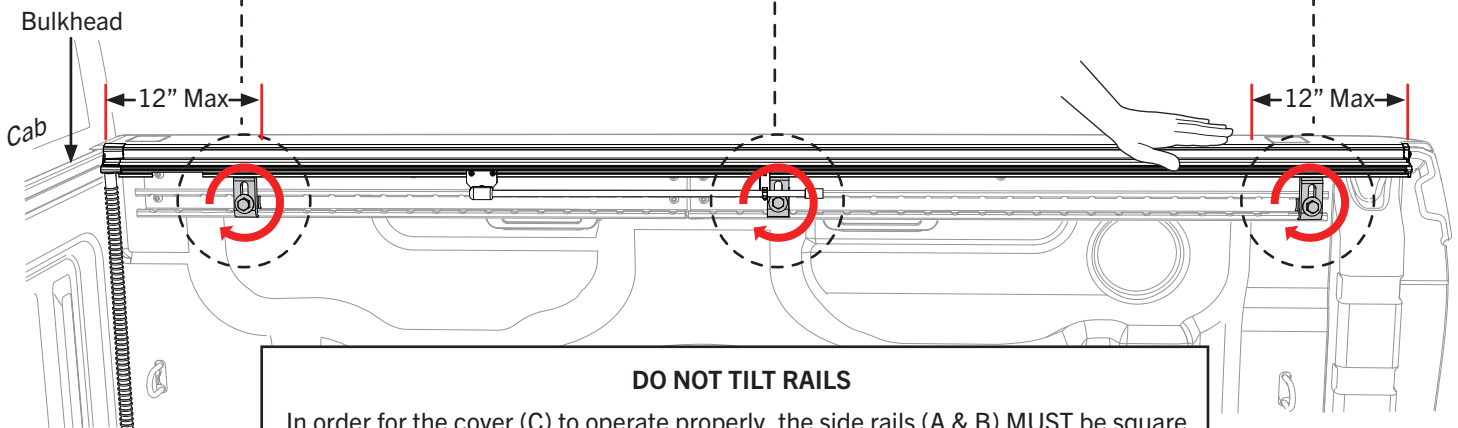

5b Push the rail against the cab/bulkhead. Secure the passenger side rail (B) to the truck bed using three clamps (G). Position the front clamp 6-8 inches from the bulkhead and place the rear clamp as close to the tailgate as possible. Center the middle clamp between them so all clamps are evenly spaced along the rail. Lightly tighten each clamp with a 1/2" wrench to ensure they engage with the side rail. **If filler strips were installed in step 2, attach the clamps (G) at filler strip (E) locations. CAUTION: Do not overtighten! Hand tighten only at this time.** ⚠️

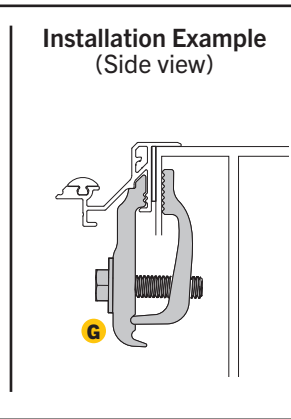
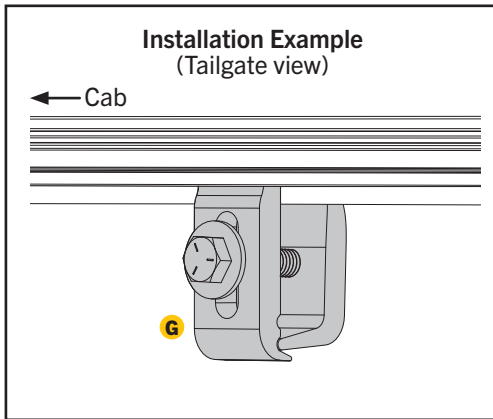
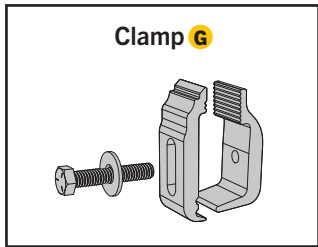

TIP: If the rails are leaning down, have one person stand on the outside of the bed and slightly roll the rails upward while another person slowly snugs the clamps up. If the clamps are tightened too quickly or overtightened, it will cause the rails to lean down.

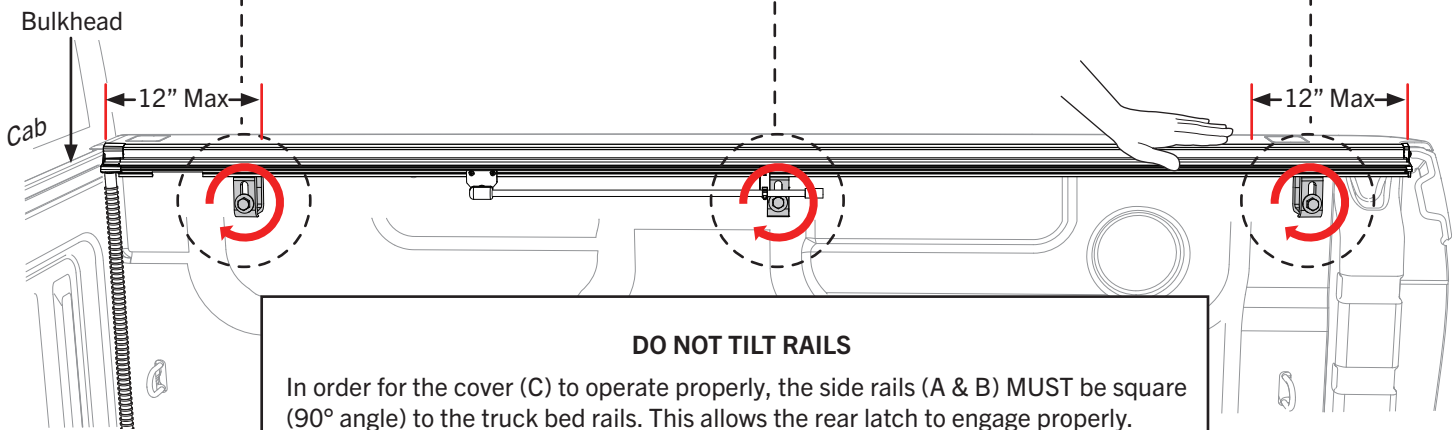

DO NOT TILT RAILS

In order for the cover (C) to operate properly, the side rails (A & B) **MUST** be square (90° angle) to the truck bed rails. This allows the rear latch to engage properly.

For the best fit of the cover (C), ensure the side rails (A & B) sit level with the truck bed cap and are not angled up or down. Position the back side of each clamp as high as possible, then tighten the clamp. Clamp notch locations may vary by model. Tighten all clamps to **10 ft-lbs. (14 Nm)** of torque using a 1/2" wrench or socket. **CAUTION: Do NOT overtighten! Repeat steps 4-5 on the opposite side with the driver side rail (A).** ⚠️

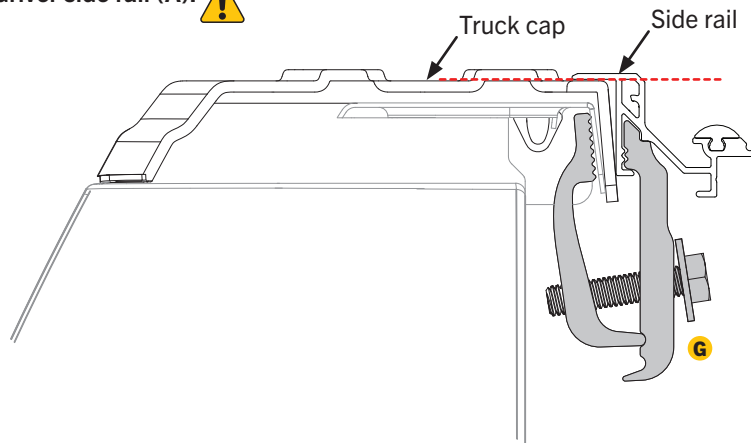

- 6** Before placing the cover (C) onto the vehicle, slide two cover retainer clamps (J) into the track on the underside of the cover (C) near the cab. Confirm the cover retainer clamps fit properly into the cover rail for optimum fit. Repeat on the opposite side of the cover.

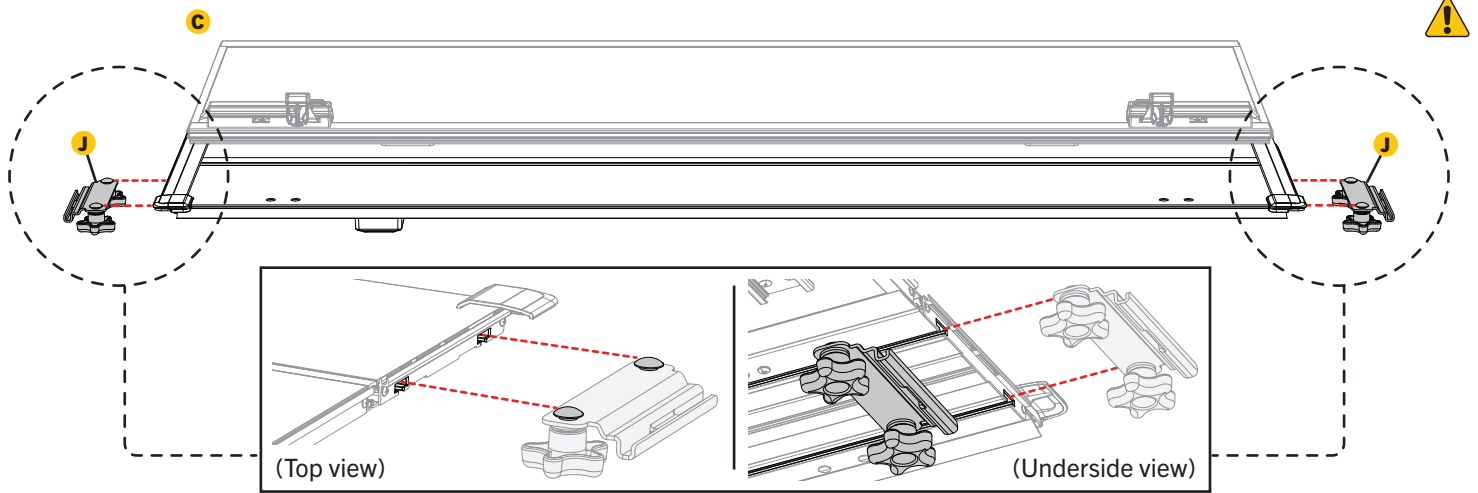

- 7** Adhere one buckle end gasket (M) to the underside of each buckle end (L) by peeling off the adhesive liner from the gasket. Position the prepped buckle ends (L) into the pre-drilled holes on the front header panel with the open sides facing the bed cover panel. Use a screwdriver to install the two buckle ends with the provided screws (K). **DO NOT use a screw gun, securely tighten by hand only.**

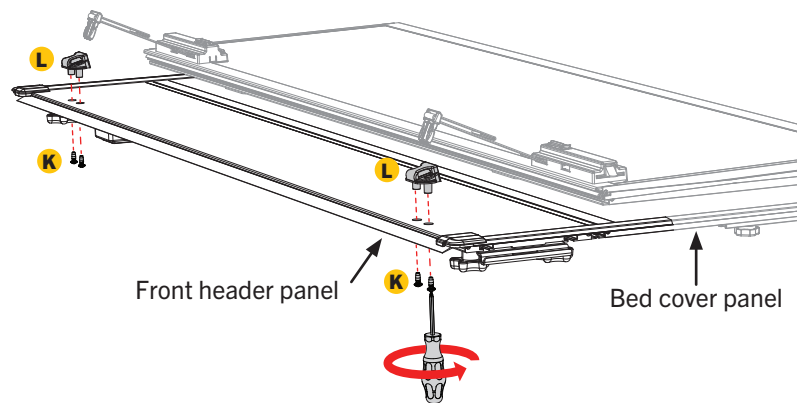
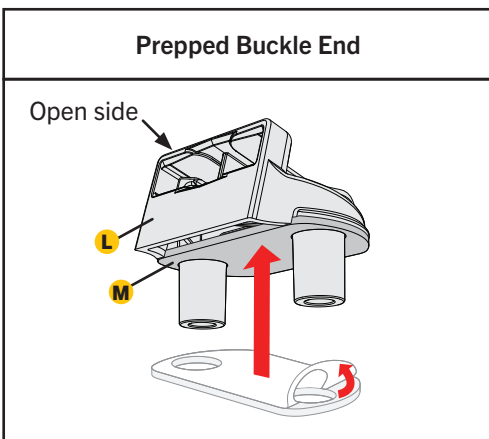

- 8** If these parts were included in your hardware kit, adhere one wedge stop gasket (O) to the underside of each wedge stop (N) by peeling off the adhesive liner from the gasket. Install the prepped wedge stop (N) to the cover by positioning the wedge stop ends into the pre-drilled holes on the front header panel with the provided screws (K). **DO NOT use a screw gun, securely tighten by hand only.**

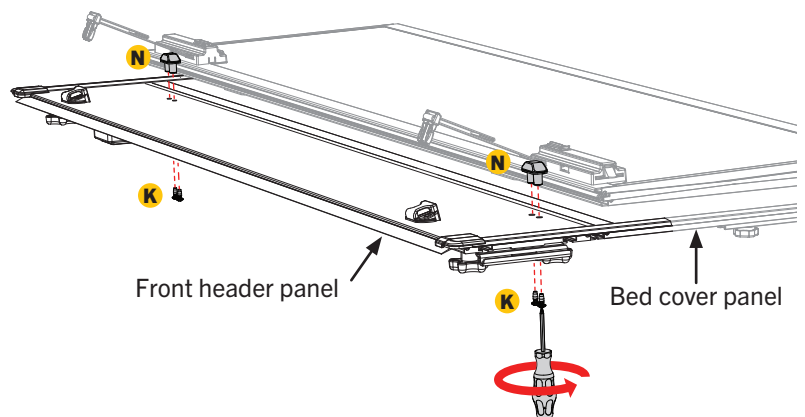
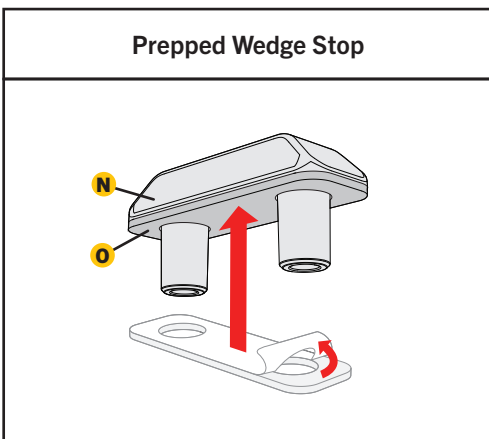

- 9** Set the cover (C) in the folded position on the side rails (A & B) towards the cab of the truck. Confirm the cover is evenly spaced between the rails.

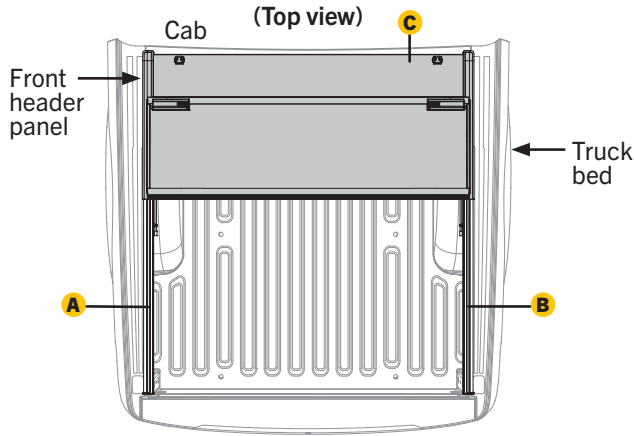

- 10** Confirm the retainer clamps (J) are positioned around the side rails (A & B) correctly as shown below. Tighten the retainer clamps by turning them clockwise until the lock washer is secure. ⚠️

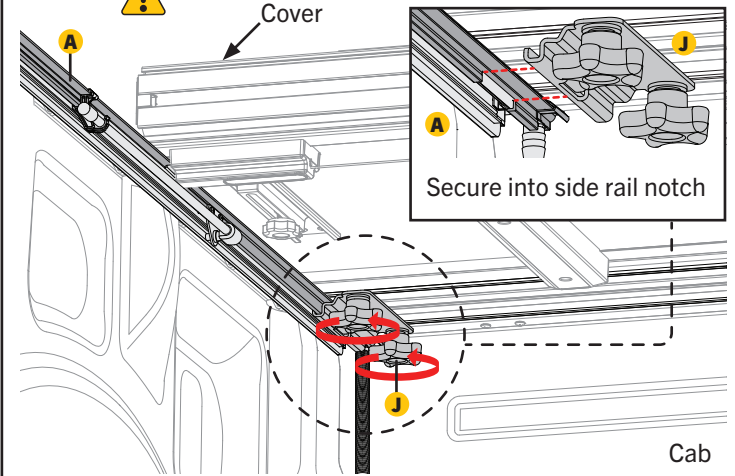

- 11** With the bed cover in the folded position, clean the area where the cab bumpers (P) will go with soap and water to remove dirt and debris. Then clean the area with isopropyl alcohol to remove wax or grease and to evaporate any remaining water, allow the surface to dry. Install the bumpers (P) evenly spaced along the top edge of the cover (C) where it meets the truck cab. Position them so that when the cover rests against the cab, the cover does not contact the rear window at any point. Apply pressure to all bumpers to make sure the adhesion is good.

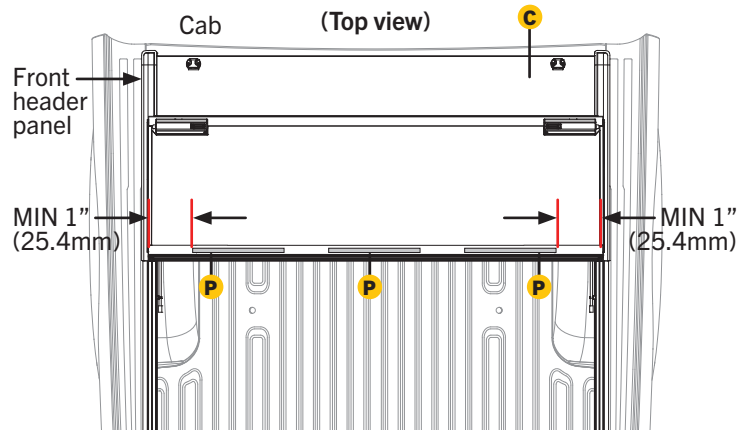
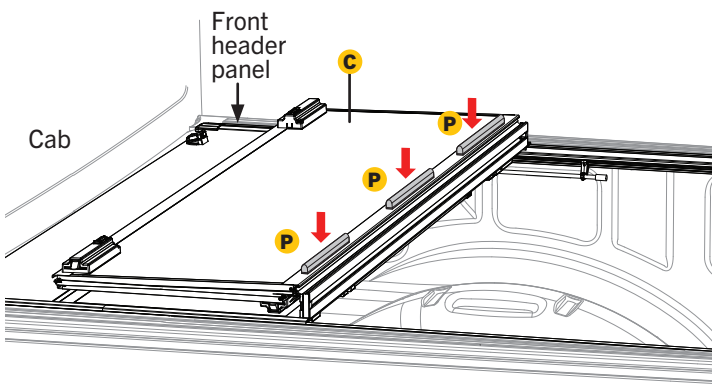

- 12** To engage the spring system on the cover (C), pull the pin wherever there is a spring present. If it does not initially engage, cycle the cover a few times by folding it down and back up. This should help the cover engage. **NOTE:** The cover can be in any position when pulling the pin.

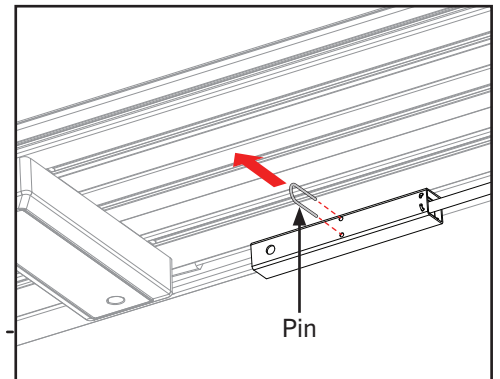
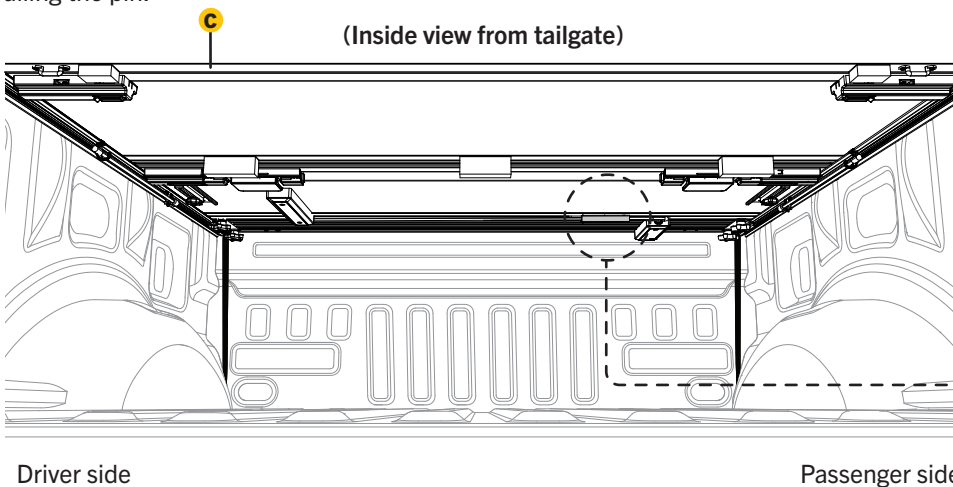

- 13** Unfold the cover (C) towards the tailgate. Confirm each panel is centered side to side and front to back on the truck bed. If adjustments are needed, loosen the cover retainer clamps (J) and shift the cover until positioned correctly. The rear edge of the cover and tailgate seal should rest on top of the tailgate.

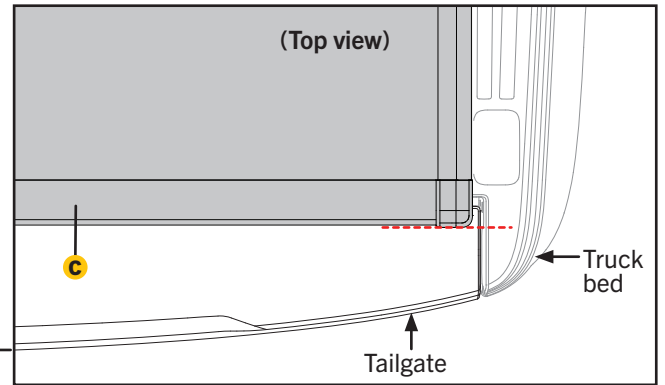
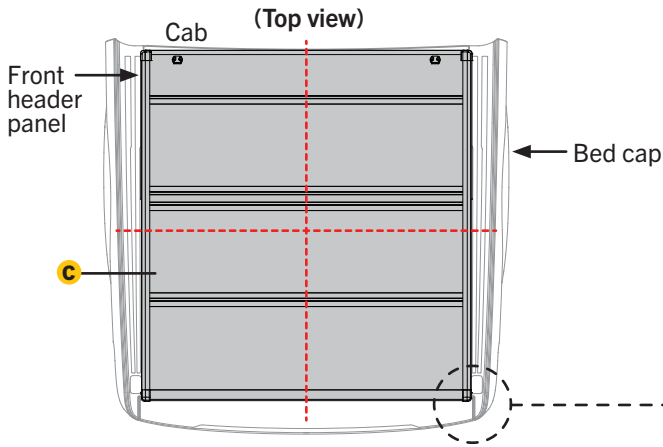

- 14** Check if the latches are hitting or not engaging the side rails (A & B) by releasing each latch. If any of the latches need modifications refer to the TROUBLESHOOTING TIPS section to make slam latch adjustments.

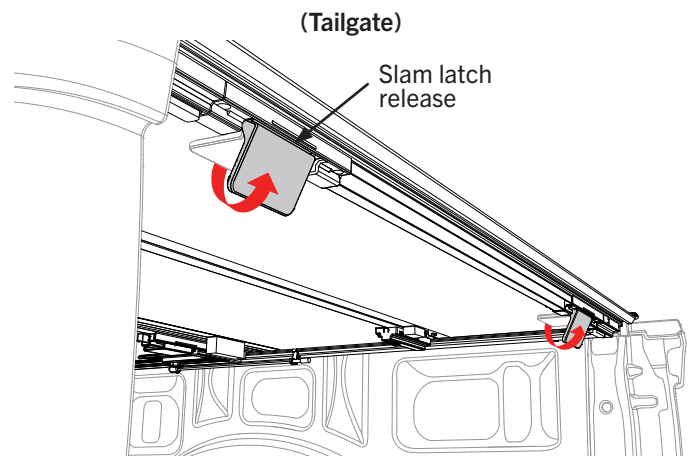
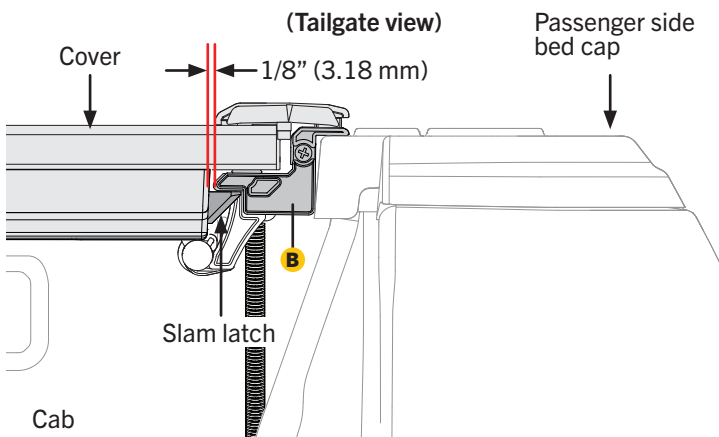

- 15** Retighten the cover retainer clamps (J) once the desired fitment is reached. **You are ready to drive with your cover in the closed position.**

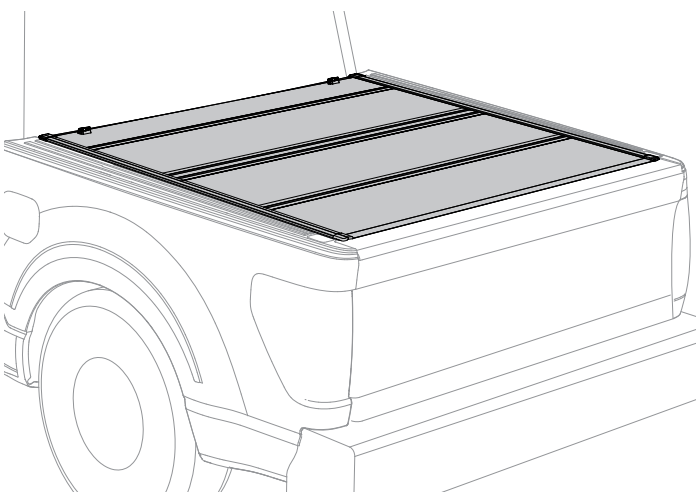

- OPENING COVER:** Lower the tailgate and pull either slam latch release handle or cable. Lift the panel up and towards the cab.

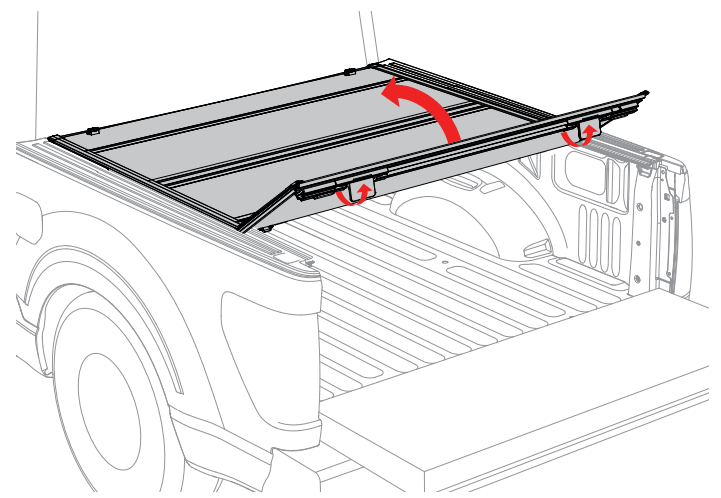

FOLDED UP POSITION: To drive with the cover (C) in the folded up position, use the straps and buckles provided with the cover. Attach the buckle into the buckle end (H) at the bulkhead, then pull the strap to take up the slack and secure the cover. 

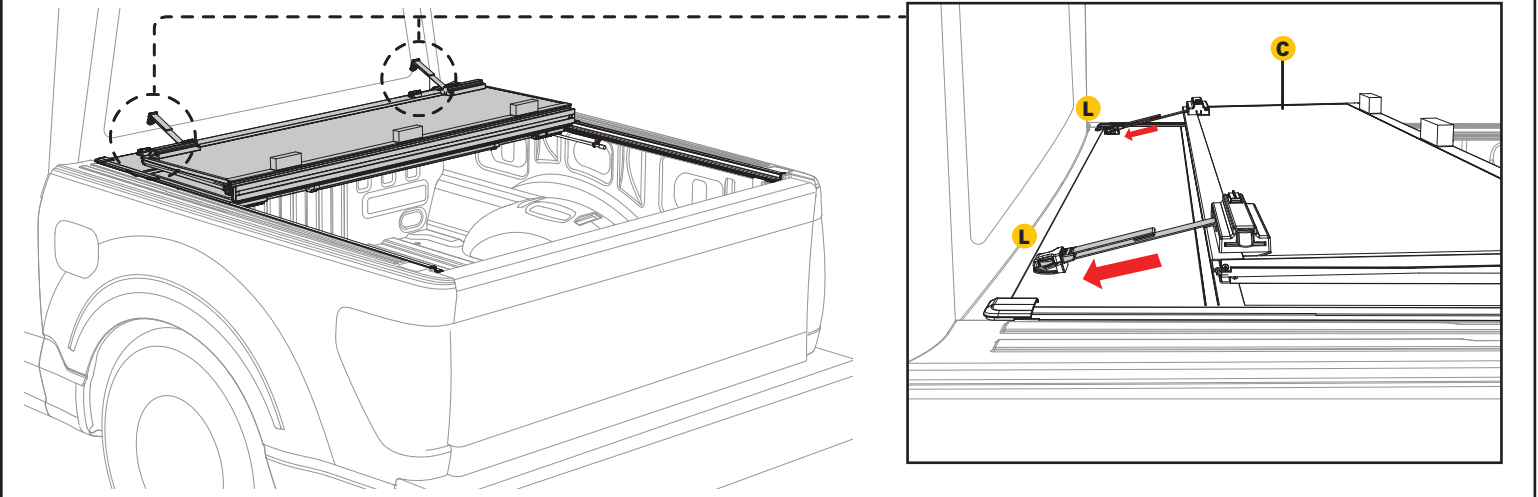

FLIPPED UP POSITION: Secure the straps under the clips located on the slam latch housings before flipping. Fold the cover (C) open and lift it until it is vertical or past 90 degrees towards the truck cab. Release the prop rod that is attached to the rail. Fold the prop rod over and position it firmly against the vertical plate on the underside of the cover. Slide the prop rod locks downwards and tighten the knobs to lock it into position. Do this on both sides of the cover. The cover should be firmly in position with little to no movement once the prop rods are locked.

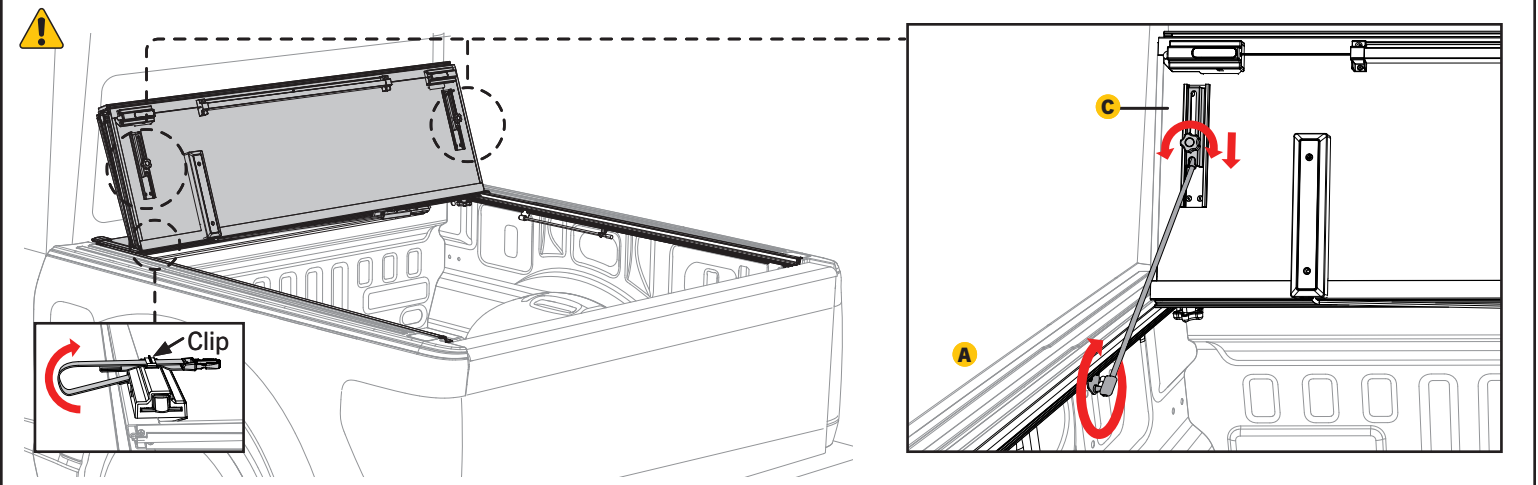

CLOSING COVER: To drive with the cover (C) closed, unhook the buckles and straps from the bulkhead. Secure the straps under the clips located on the slam latch housings. Fold all panels towards the tailgate making sure that all latches are engaged.

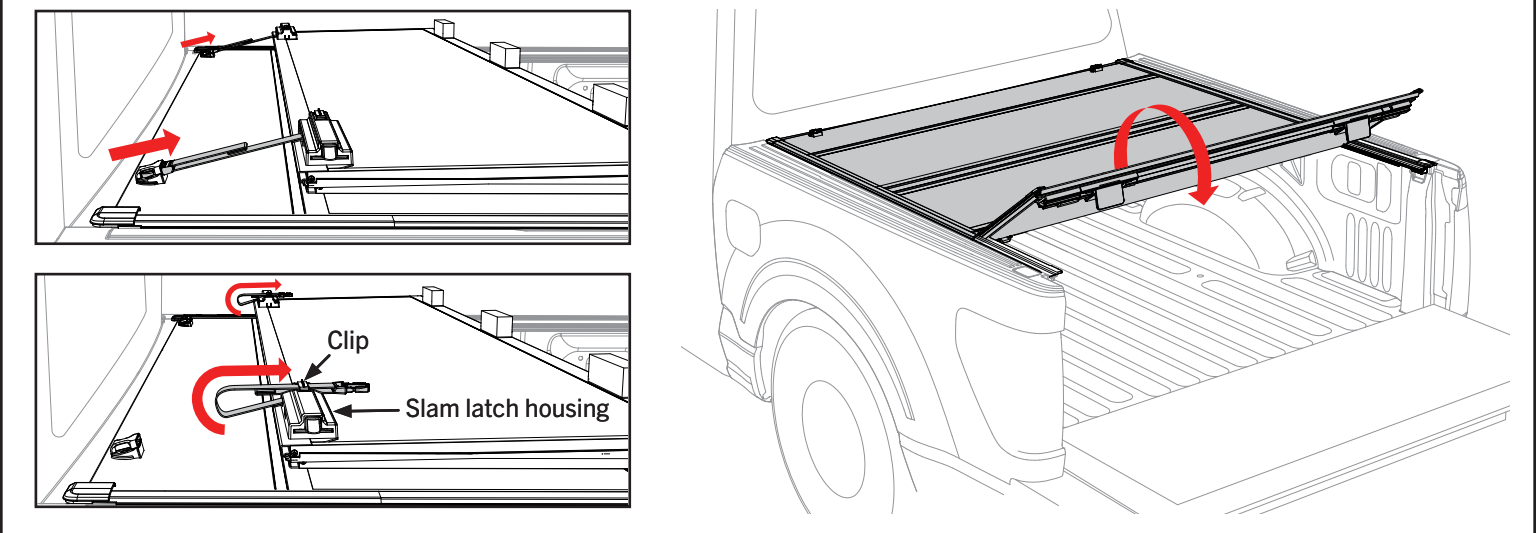

REMOVING THE COVER: Lay the cover (C) against the cab. Loosen the retainer clamps (J) from the driver and passenger side rails (A & B) on the front header panel of the cover (C). Once the clamps are released, lift the entire assembly off as a folded unit. ⚠

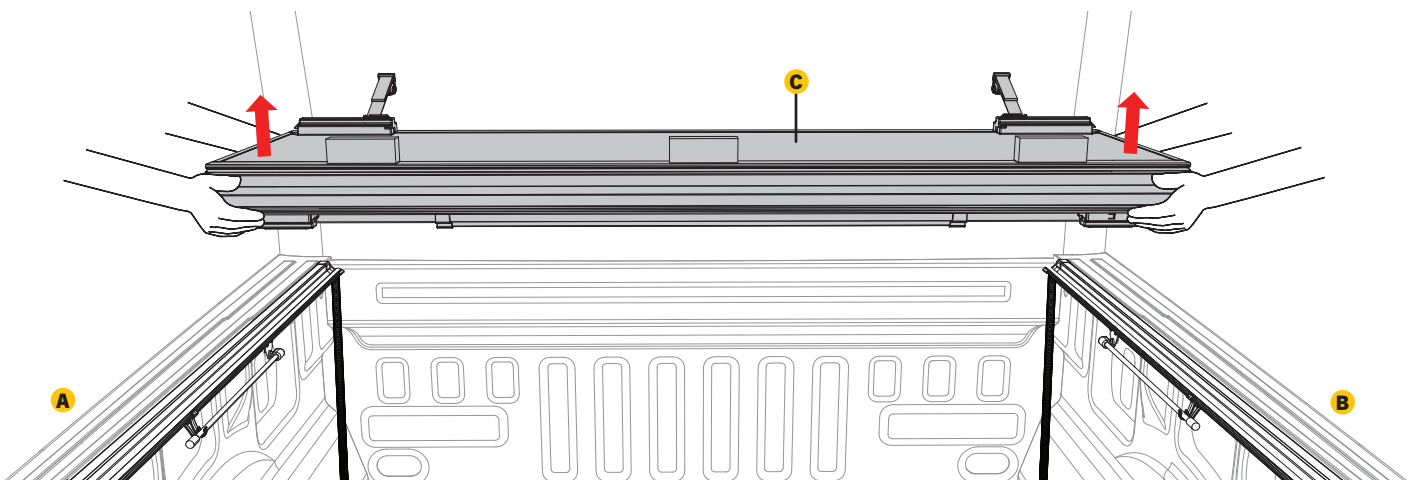
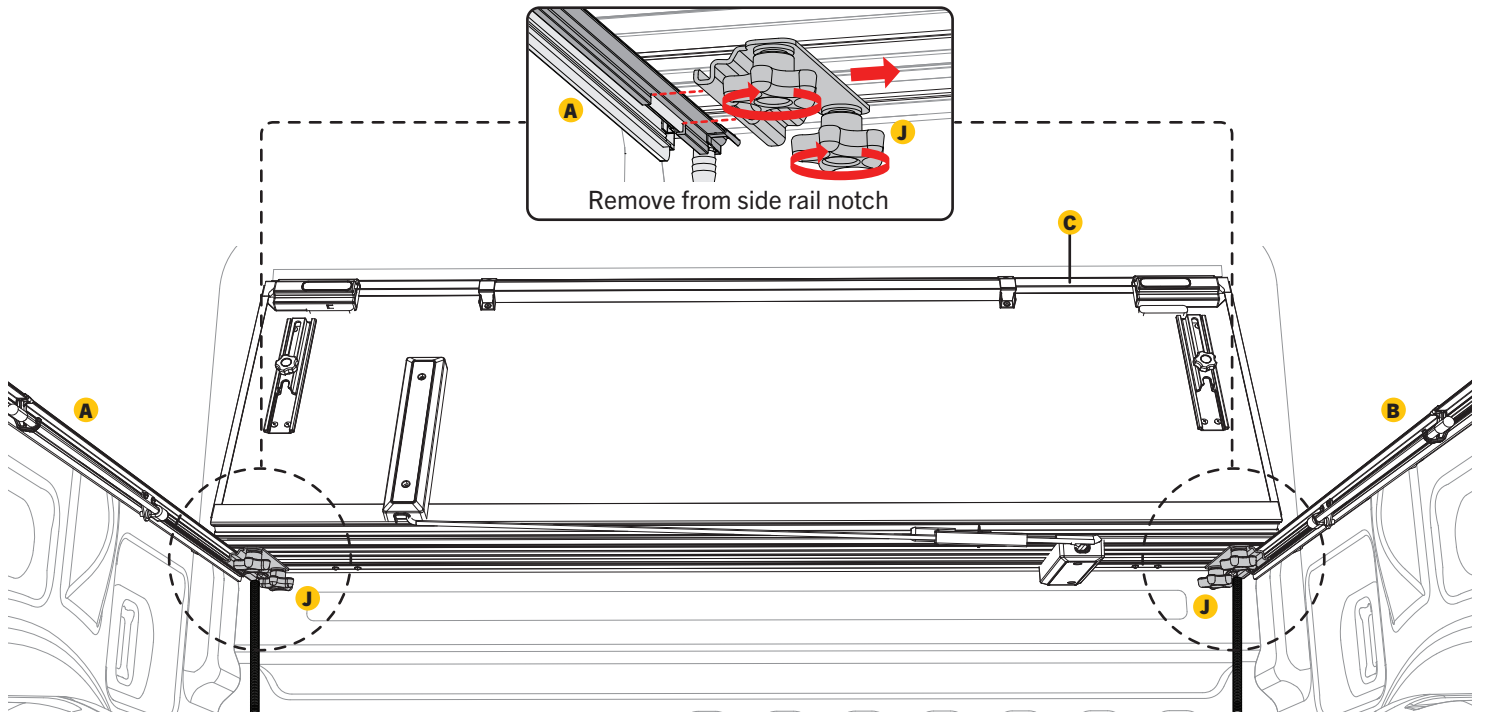
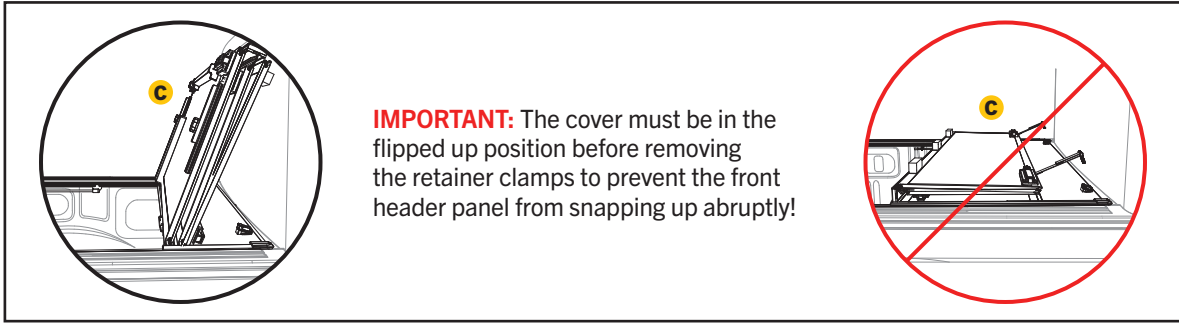

TROUBLESHOOTING TIPS

ADJUSTING SLAM LATCH

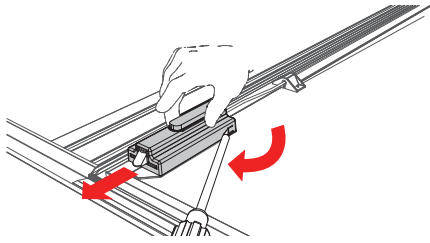

Use a screwdriver to partially pry open the tab on the latch housing. At the same time slide the housing away from the latch assembly.

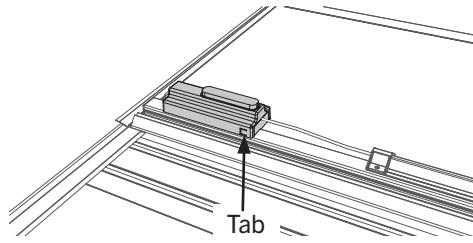

NOTE: that the tab is located on the opposite side of the housing on the passenger side of the cover.

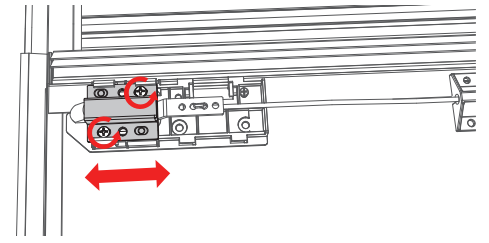

With the latch cover removed, loosen the screws and move the latch bracket to adjust. Retighten the screws. Slide the latch housing back on.

Leaning Rails: Improper engagement of the clamps can cause the rails to appear tilted inward. To ensure the clamps are properly installed loosen the nut. Adjust the clamp(s) until you have full engagement of sections 1 & 2, as shown below. When the clamp and rail are properly engaged an audible click will be heard. Overtightening the bolt can also contribute to tilted rails. **Do NOT over torque the bolt.**

NOTE: Clamps may need to be installed in the bed flange cutouts to assist with rail installation.

PROPER RAIL & CLAMP ENGAGEMENT

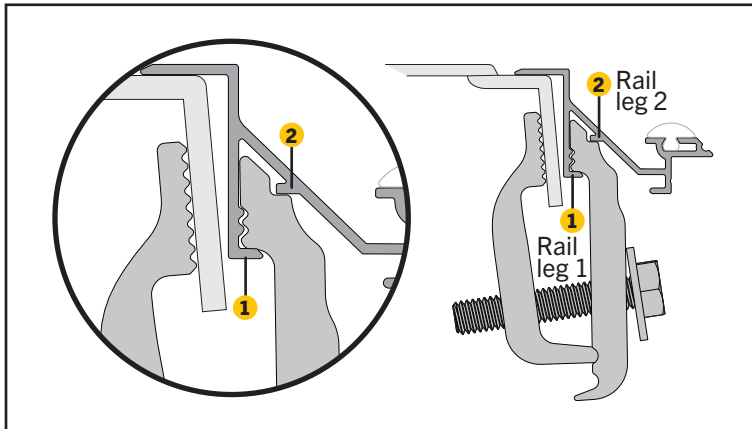

IMPROPER RAIL & CLAMP ENGAGEMENT

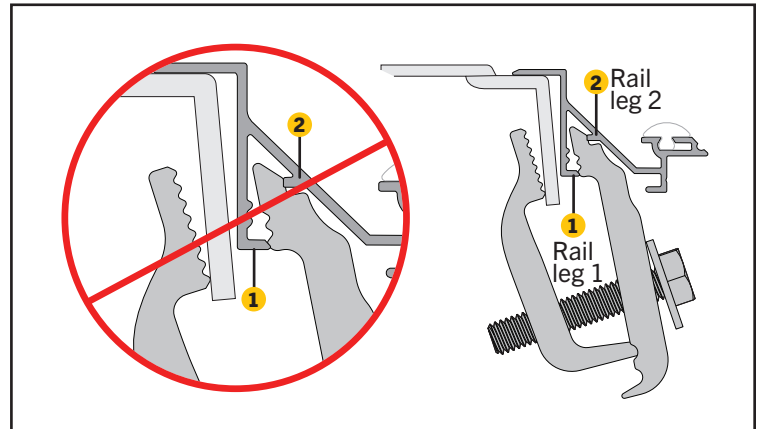

Water Intrusion: Make sure the retaining clamps are tight and properly engaged to the side rails. Check that the bulkhead seal is in place and the cover is resting on it. Make sure that all latches are engaged to the side rails and adjust if needed. Check that the side rails are installed flush with the top of the bed rail.

Sticking Latch: The cable could be pinched in or under the cable guide extrusion. Loosen the three screws on the center cable cover (bar), located in the middle of the panel. Slightly lift up on the cable guide extrusion. Pull on both sides of the cable.

Wavy Side Seal: The seal may be wavy when removed from the box. Allow ample sunlight for seal to lay flat and relax.

CARE AND MAINTENANCE

The truck bed cover requires occasional cleaning with mild automotive soap and water only. Avoid using abrasive cleaners as they may dull the finish. Some chemicals and fluids such as insect repellents, oils, solvents, and lubricants could potentially damage the rubber hinges and seals and void the warranty.

CAUTION

Always read the ingredients of any product you are using to clean your truck bed cover. Make sure that you use only products that are safe for use with rubber. Many cleaners contain chemicals that could permanently discolor or damage your hinges and seals.



Periodically check that your cover is securely attached to your truck bed and working as intended. Inspect all hardware such as clamps and cover retainer clamps to ensure they are properly installed and working as intended. Covers that are used at high frequency or subject to rough roadways and/or heavy vibration conditions may cause the cover to require adjustment.

It is also recommended that you regularly inspect and service each panel latch. Clean away any excess dirt or grime. Ensure all latches move freely in and properly engage the side rail to provide optimal performance and security.



SAFETY INSTRUCTIONS

- DO NOT place objects on or against cover or framework.
- DO NOT tie cargo to truck bed cover or framework.
- DO NOT operate vehicle with objects on top of the cover.
- NEVER allow children or pets to occupy the truck bed with the cover in the fully closed position.
- The cover is not airtight. Special care is required to keep cargo clean and dry.
- Truck bed covers will not prevent theft of contents inside the truck bed.

LIMITED WARRANTY

Thank you for purchasing a RealTruck truck bed cover (the “Product”). RealTruck Enterprise, Inc. (“Warrantor”) is proud to have you as a customer and hopes you will be pleased with the years of service your Product provides. Please take a few moments to review the below warranty information, and be sure to complete the online warranty registration for your convenience in receiving warranty service, future promotions, and new product information.

The warranty contained on the information sheet accompanying the Product establishes the warranty terms applicable to the Product, and controls over any additional, different, or inconsistent terms that may be found on other products or on the RealTruck website.

THIS WARRANTY GIVES YOU SPECIFIC LEGAL RIGHTS, AND YOU MAY ALSO HAVE OTHER RIGHTS WHICH VARY FROM STATE TO STATE.

Warranty Beneficiary

This warranty extends to the original purchaser of the Product warranted under this warranty (the “Consumer”). It does not extend to any subsequent owner or other transferee of the Product.

This warranty covers the Product and each of its component parts, and warrants that they will be free from failure due to defects in materials or workmanship.

Warranty Coverage

The term of this warranty begins on the date Product is purchased by the original purchaser or, if purchased other than in person, on the date Product is delivered to the original purchaser, and continues, for 5 years.

Warranty Exclusions and Limitations

The warranty duration is not extended by repair or replacement of the Product. Warrantor may change the availability or duration of this warranty at Warrantor’s discretion, but any subsequent changes will not be retroactive or apply to your Product.

This warranty does not cover damage caused by misuse, abuse, or accident such as: neglect, lack of maintenance, care inconsistent with care instructions, normal wear and tear, vehicle alterations or additions (other than by an authorized RealTruck dealer or under direction of Warrantor), unauthorized repair, transportation, collision, off-road driving, use in competitive racing, vibrations from worn or altered suspension systems or sound equipment, and/or acts of nature including but not limited to tornados, hurricanes, hail, and earthquakes.

THERE ARE NO OTHER PRODUCT WARRANTIES, EXPRESSED OR IMPLIED, INCLUDING, WITHOUT LIMITATION, ANY IMPLIED WARRANTY OF MERCHANTABILITY OR IMPLIED WARRANTY OF FITNESS FOR A PARTICULAR PURPOSE, WHICH EXTEND BEYOND THE ABOVE WARRANTY DURATIONS. SUCH WARRANTIES ARE DISCLAIMED. SOME STATES DO NOT ALLOW LIMITATIONS ON HOW LONG AN IMPLIED WARRANTY LASTS, SO THE ABOVE LIMITATION MAY NOT APPLY TO YOU.

FOR BREACH OF ANY EXPRESS OR IMPLIED WARRANTY ON THIS PRODUCT, THE CONSUMER IS LIMITED TO THE FOLLOWING RELIEF, AT WARRANTOR’S ELECTION: REPAIR, REPLACEMENT OF DEFECTIVE PART(S) BY AN AUTHORIZED REALTRUCK DEALER OR UNDER DIRECTION OF WARRANTOR, OR REFUND. WARRANTOR RESERVES THE RIGHT TO REPLACE ANY PART(S) WITH CURRENT PRODUCTION PART(S) OF EQUAL OR GREATER QUALITY AND VALUE.

WARRANTOR’S LIABILITY SHALL UNDER NO CIRCUMSTANCES EXCEED THE ACTUAL COST OF REPAIRING OR REPLACING THE DEFECTIVE PART(S), NOR SHALL WARRANTOR UNDER ANY CIRCUMSTANCES BE LIABLE FOR ANY CONSEQUENTIAL, INCIDENTAL, SPECIAL, OR PUNITIVE DAMAGES OR LOSSES, WHETHER DIRECT OR INDIRECT.

SOME STATES DO NOT ALLOW THE EXCLUSION OR LIMITATION OF INCIDENTAL OR CONSEQUENTIAL DAMAGES, SO THE ABOVE LIMITATION OR EXCLUSION MAY NOT APPLY TO YOU.

Warranty Process

In-Store and Dealer Purchases: To seek warranty service for Products purchased in-store or through an authorized RealTruck dealer, Consumer may return the Product to the authorized RealTruck dealer from which Consumer purchased the Product. Consumer must present personal identification and proof of purchase of the Product. The authorized RealTruck dealer is responsible for processing Consumer warranty claims and coordinating with RealTruck regarding warranty service. If Consumer is unable to return the Product to the original authorized RealTruck dealer, Consumer may visit <https://realtruck.com/warranty-policies/> to contact RealTruck directly regarding warranty service.

Online Purchases: To seek warranty service for Products purchased online through www.realtruck.com, or Products purchased online through an authorized online retailer after the authorized online retailer's return period, Consumer must visit www.realtruck.com/warranty-policies/ and contact RealTruck using the "SUBMIT WARRANTY CLAIM" link. Consumer must provide proof of purchase of the Product.

Contact Us

If you have questions about this warranty, contact RealTruck online at <https://realtruck.com/contact-us/>, by phone at (866) 519-0675, or by mail at 5400 Data Court, Ann Arbor, MI 48108.

**REGISTER
YOUR
WARRANTY
ONLINE**

