

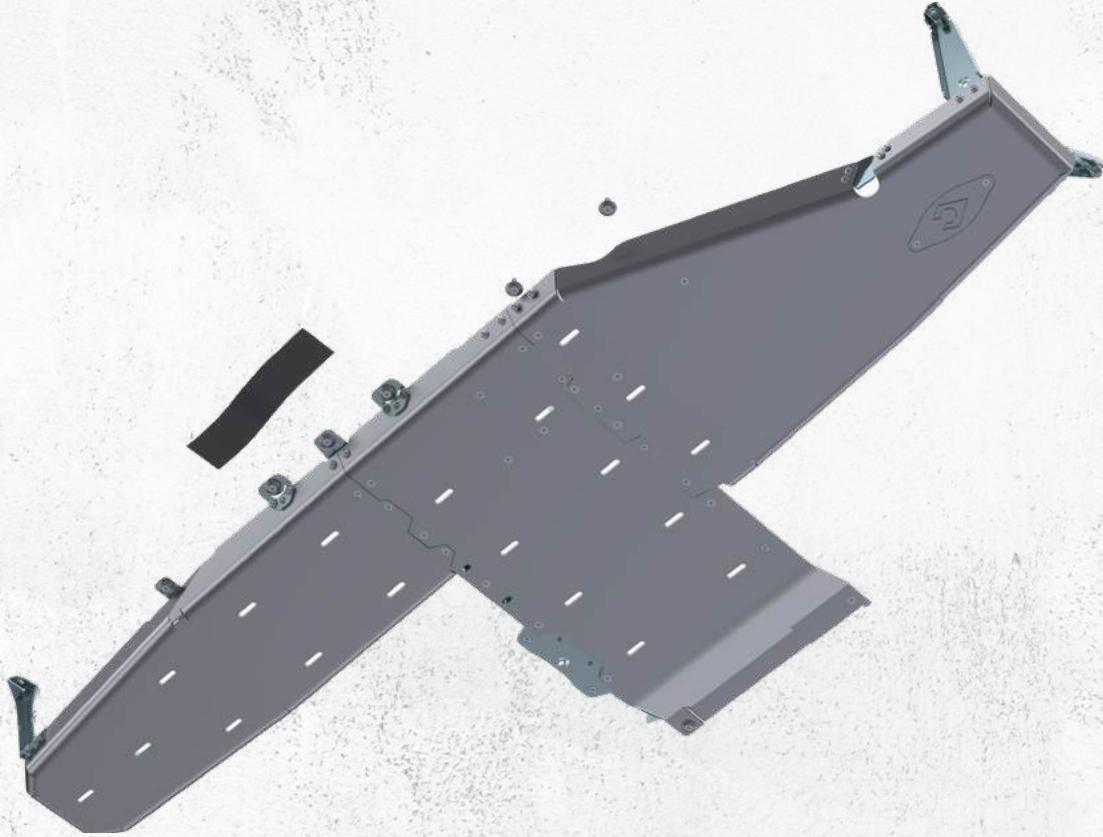

JL411

4XE BELLYPAN SKID W/ OIL DOOR



ESTIMATED INSTALLATION TIME

3 hours

REQUIRED SKILLS

- General Mechanics Skills

REQUIRED TOOLS & SUPPLIES

- 7/32 Hex Bit
- 5/32 Hex Bit
- 5/16 Hex bit
- 10mm Socket
- 13mm Socket
- 15mm Socket
- 18mm Socket
- Ratchet strap
- Ruler
- Jack/ support
- Magnet pen/ stick
- 1/4 inch drill bit
- 3/8 inch drill bit
- Drill
- Cutting tool such as a angle grinder / die grinder or other.

NOTES:

- Component appearance in instructions may vary from those received

WARNING MESSAGES

This product demands a basic understanding of mechanical procedures and should only be installed by individuals proficient with mechanic's tools. Any tasks involving welding or cutting parts should be performed by trained professionals. Artec Industries disclaims responsibility for mishaps arising from improper installation, or any damage or accidents resulting from cutting or welding tasks. Exercise caution and seek professional help as required.

SAFETY

1. We've furnished a written installation guide, along with relevant details, to aid you in making safety-conscious decisions.
2. While these guidelines will highlight potential risks, it's crucial to exercise your personal judgment when performing any required steps.
3. Before initiating any tasks, it's essential to conduct a job safety analysis to identify specific hazards in your situation and take measures to eliminate or protect against them.
4. Before commencing the installation of this product, make sure you familiarize yourself with and fully understand all safety warnings and guidelines.

DISCLAIMERS

All Artec Industries products should be installed by a competent, certified individual following the intended installation instructions for each product. Incorrect installations not only nullify any warranties but could also lead to product damage or even damage to the vehicle it's installed on. Prior to installation, carefully read all provided instructions or manuals, and watch any associated videos. For any doubts or queries, reach out to Artec Industries before beginning the installation process.

Many products necessitate lifting and supporting the vehicle off the ground. It is the installer's responsibility to ensure this can be done safely and that the right equipment is at hand to carry out the installation. Artec Industries installation instructions presume the installer is competent to lift the vehicle safely and correctly.

Modified vehicles won't perform identically to their stock counterparts. It's incumbent upon the vehicle owner to understand the alterations such modifications will bring to the vehicle's driving dynamics. These might encompass (but aren't limited to): changes in handling, braking, rollover angle, and potential incompatibilities with the factory-installed anti-lock braking systems, stability control systems, or traction control systems.

SPECIAL NOTES

- Unless otherwise noted, all hardware should be **LOOSELY** tightened by hand until the very end of installation when all components are attached.

JL4111 PARTS BILL OF MATERIALS

Please confirm you have all the listed parts below **BEFORE** beginning your installation. If any parts are damaged or missing, **KEEP ALL ORIGINAL BOXES and PACKAGING** and contact us.

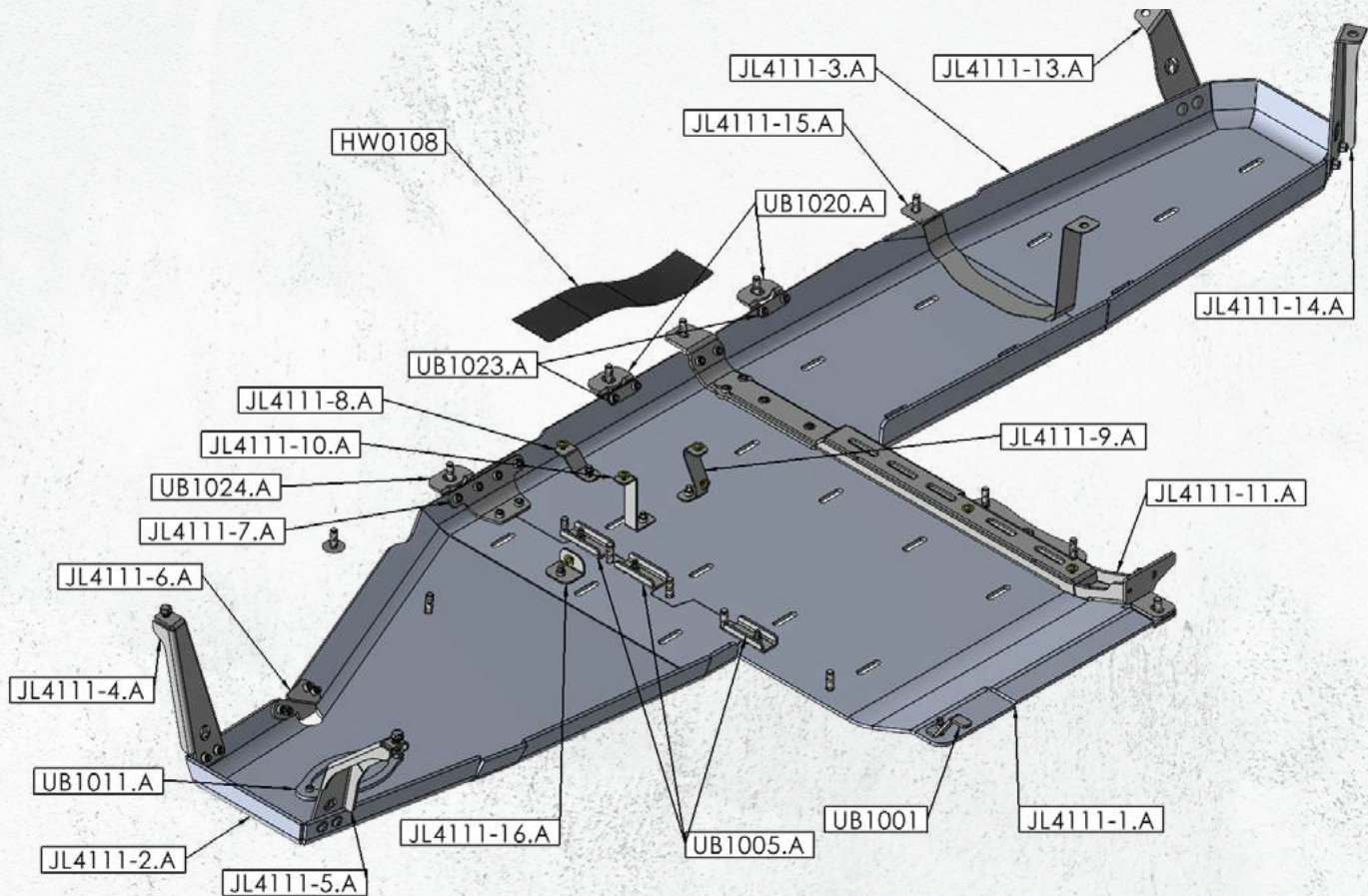

NOTE: The part numbers indicated above end in a "." and "letter" which indicate the revision number for the part. The etched part number on your physical parts do not need to match the above drawing revision exactly.

JL4111 BILL OF MATERIALS

ITEM NO.	PART NUMBER	DESCRIPTION	QTY.
1	HW0019	3/8"-16 Nylock Insert Hex Nut Clear Zinc	4
2	HW0033	Zinc-Plated Steel USS Washer, Grade 5, for 1/4" Screw Size, 0.313" ID, 0.750" OD	9
3	HW0035	3/8" 16 x .75" long button head screws ZINC plated	2
6	HW0059	3/8" Flat Washer Type 1 Yellow Zinc	29
7	HW0061	3/8 x 1 flat head bolt	10
8	HW0062	1/4"-20 x 3/4 Button Head Socket Cap Screw Zinc Plated	9
10	HW0101	3/8 x 16 x 1 Button Head Cap Screw Alloy Steel Zinc Plated	28
11	HW0105	3/8 x 1in carriage bolt	4
15	HW0135	M10 x 1.5mm - Flange Lock Nut	2
16	HW0136	M10 - 1.5 x 40mm long Hex Head Bolt	2
17	HW0137	M10 washer	2
18	HW0147	.375" Countersunk Aluminum Washer	9
19	HW0185	3/8" x 1.5 Countersink Allen Head Bolt - Zinc	4
20	HW0224	M12-1.5x40mm CUSTOM 10.9 Steel Counter Sink Allen Head Bolt - MAGNI 565 COATING	17
22	HW0266	3/8 x 3/4" flat head boll	6

DISASSEMBLY INSTRUCTIONAL GUIDE



Step 1:

Remove the four factory bolts on the small engine skidplate using a 13mm socket.

Reinstall bolts after removal!

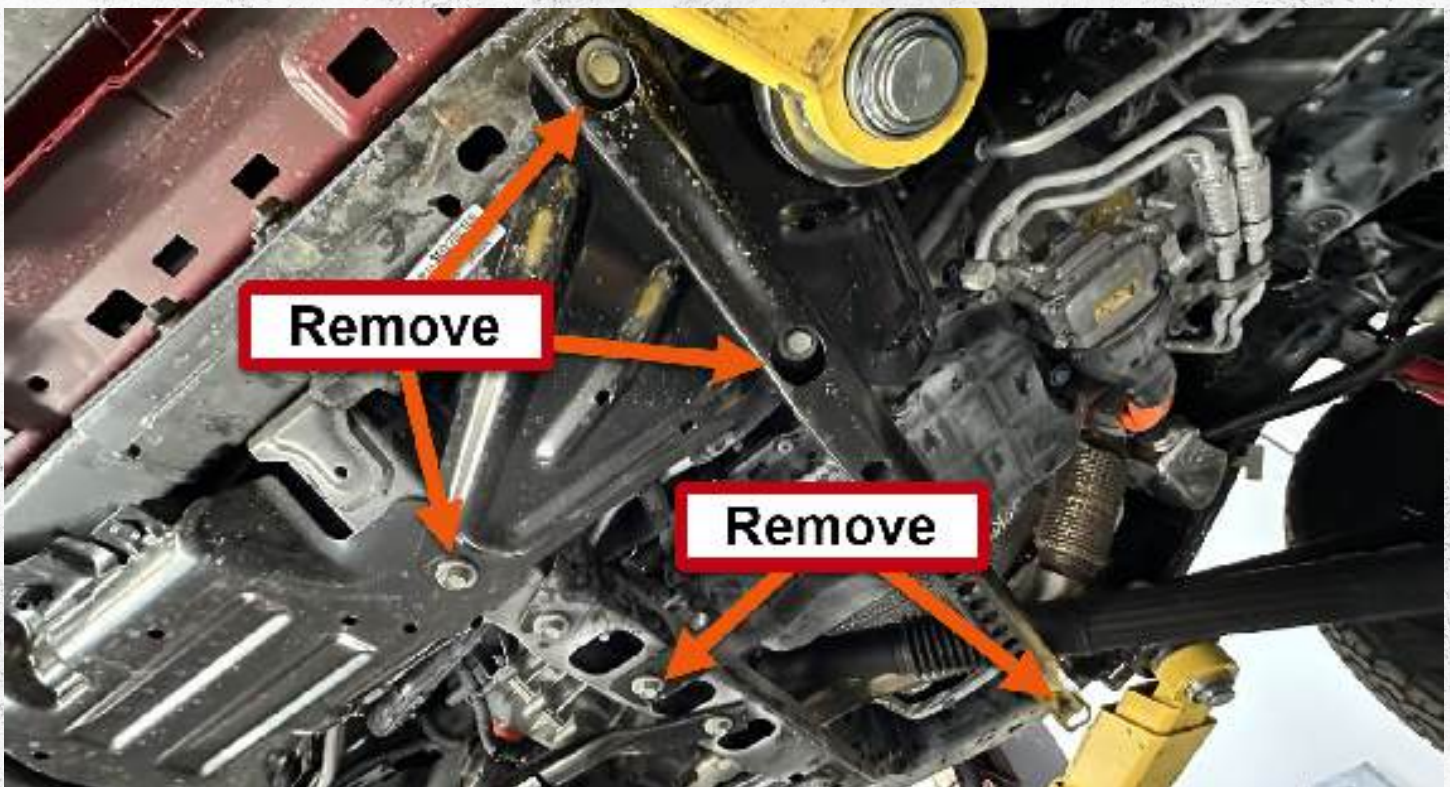

Step 2:

Remove the five factory bolts on the factory front brace using an 18mm socket.

DISASSEMBLY INSTRUCTIONAL GUIDE

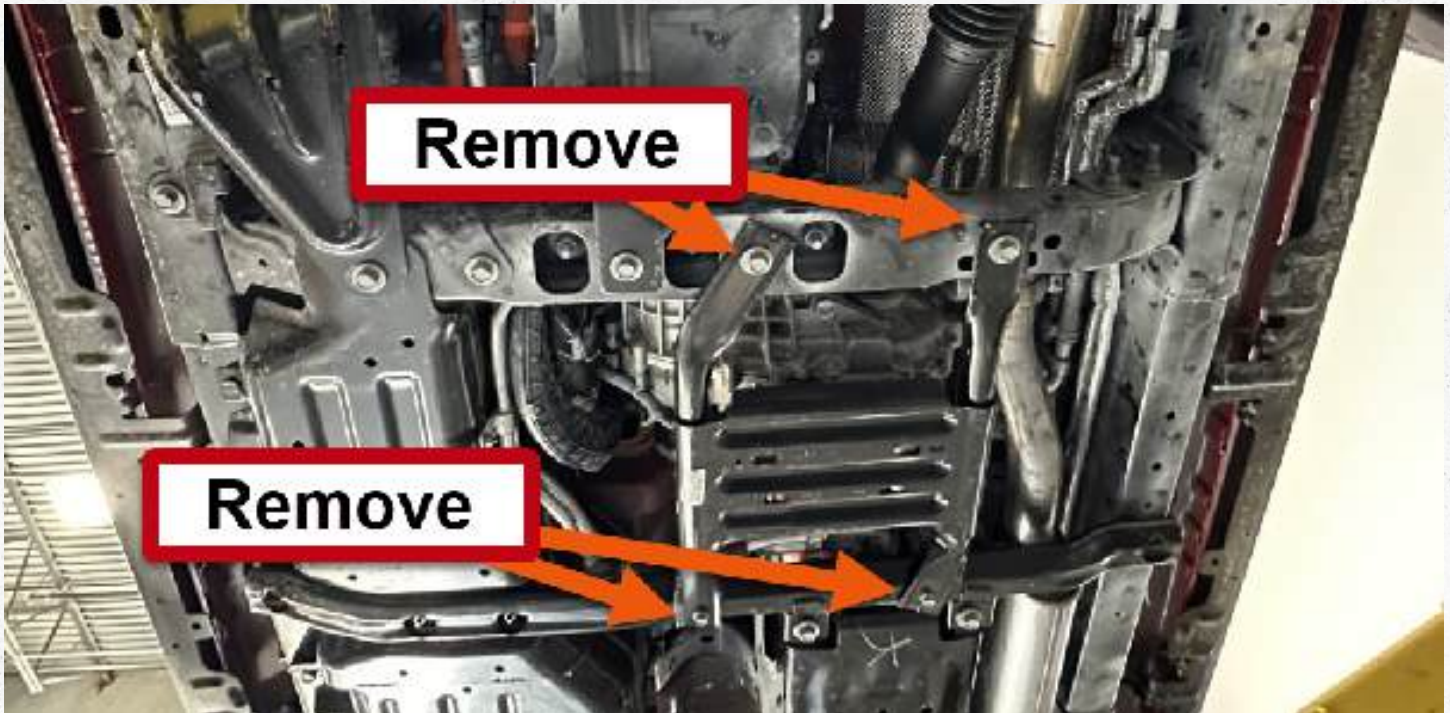

Step 3:

Remove the factory t-case skid plate by uninstalling factory bolts using a 18mm and 13mm socket.

Keep the removed bolts for re installing the factory t-case skid plate after the new engine skid plate is installed.

ASSEMBLY INSTRUCTIONAL GUIDE



Step 4:

Gather your materials **JL4111-2**, **JL411-4**, **JL4111-5**, **JL4111-6**, **UB1024** and assorted hardware.

Important!! Leave all hardware loose until the end of installation.

Step 5:

Install bracket **JL4111-6** into **JL4111-2** using 4 button head bolts with zinc plated washers.

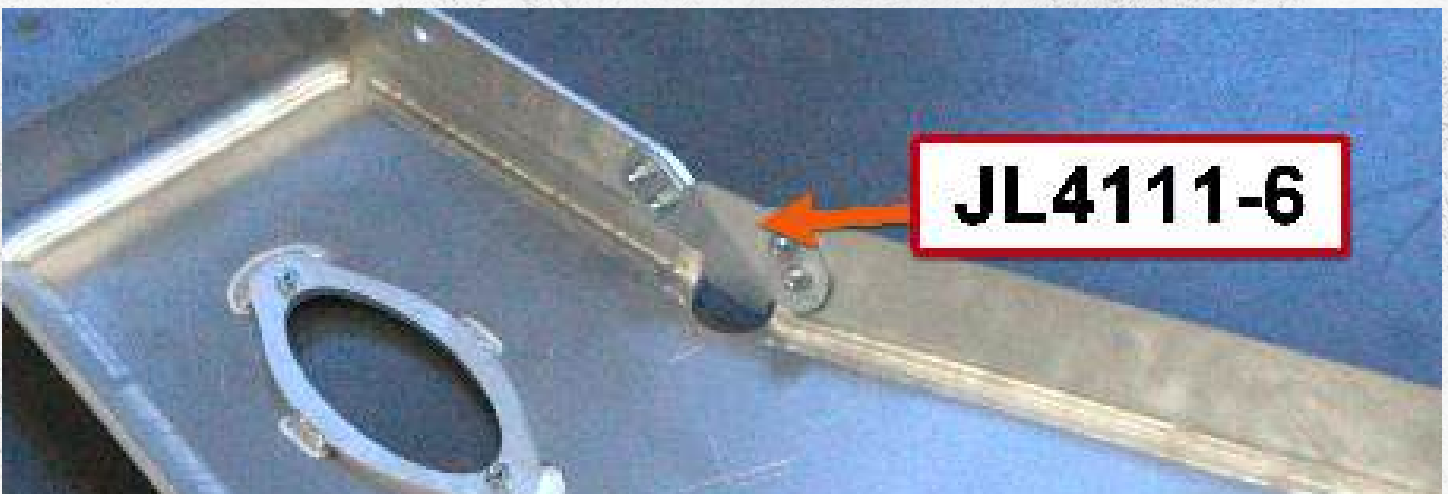



Step 6:

Cut the bracket mounted above parallel to the bottom of the cross member so that it sits flush with the cross member. Drill a 1/4" hole in the center of the bracket, indicated by the marker. **See step 9.**

The 1/4" inch hole is located in the center of the bracket between the two indents in the bracket. The new bracket should be used to locate the hole, this bracket sits flush with the cross-member.

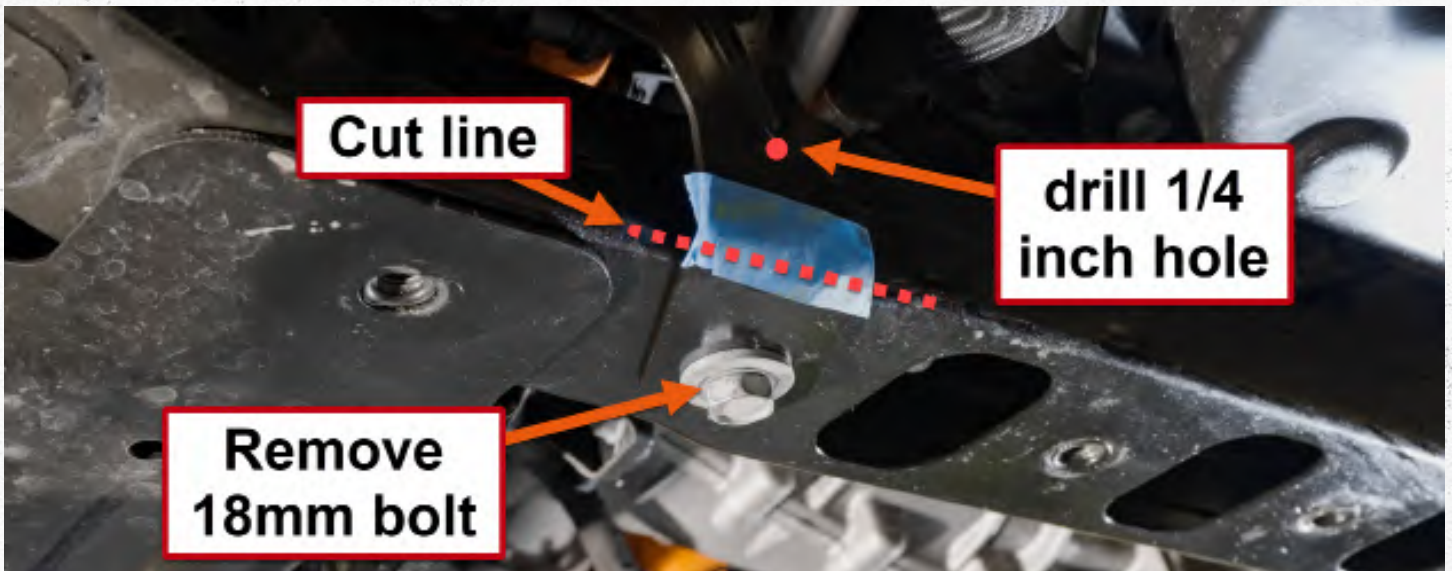



Step 7:

Cut the “bubble” off the bracket mounted to the frame along the bottom of the seam and cut flush.

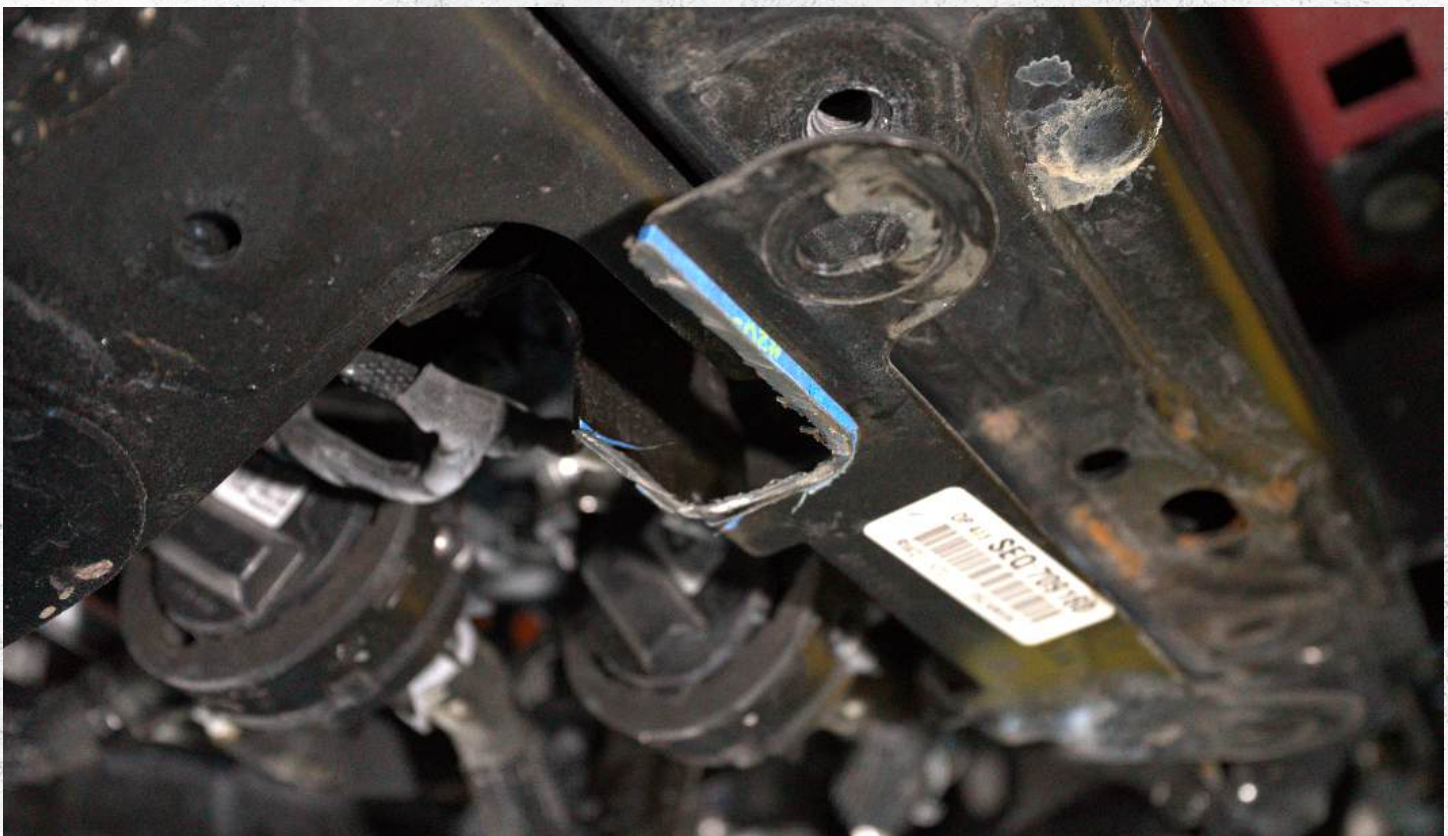

Additional view of step 7.

The “Bubble” is located on the passenger side in front of the factory cross-member.

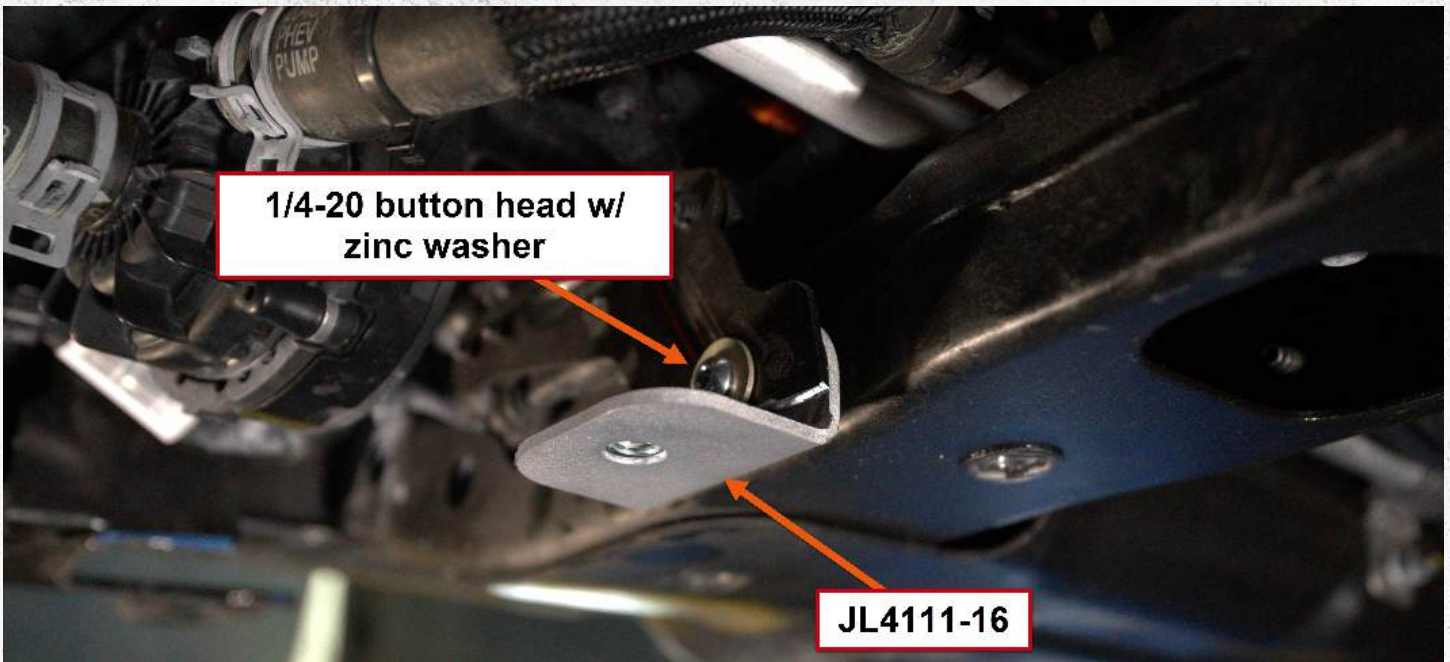

Step 8:

Install bracket **JL4111-16** in between the cut bracket and the cross-member. Use the provided 1/4"-20 button head bolt and a zinc washer to secure it into place.

Important! Tighten this bolt fully, it will not be accessible after the engine skid is installed.

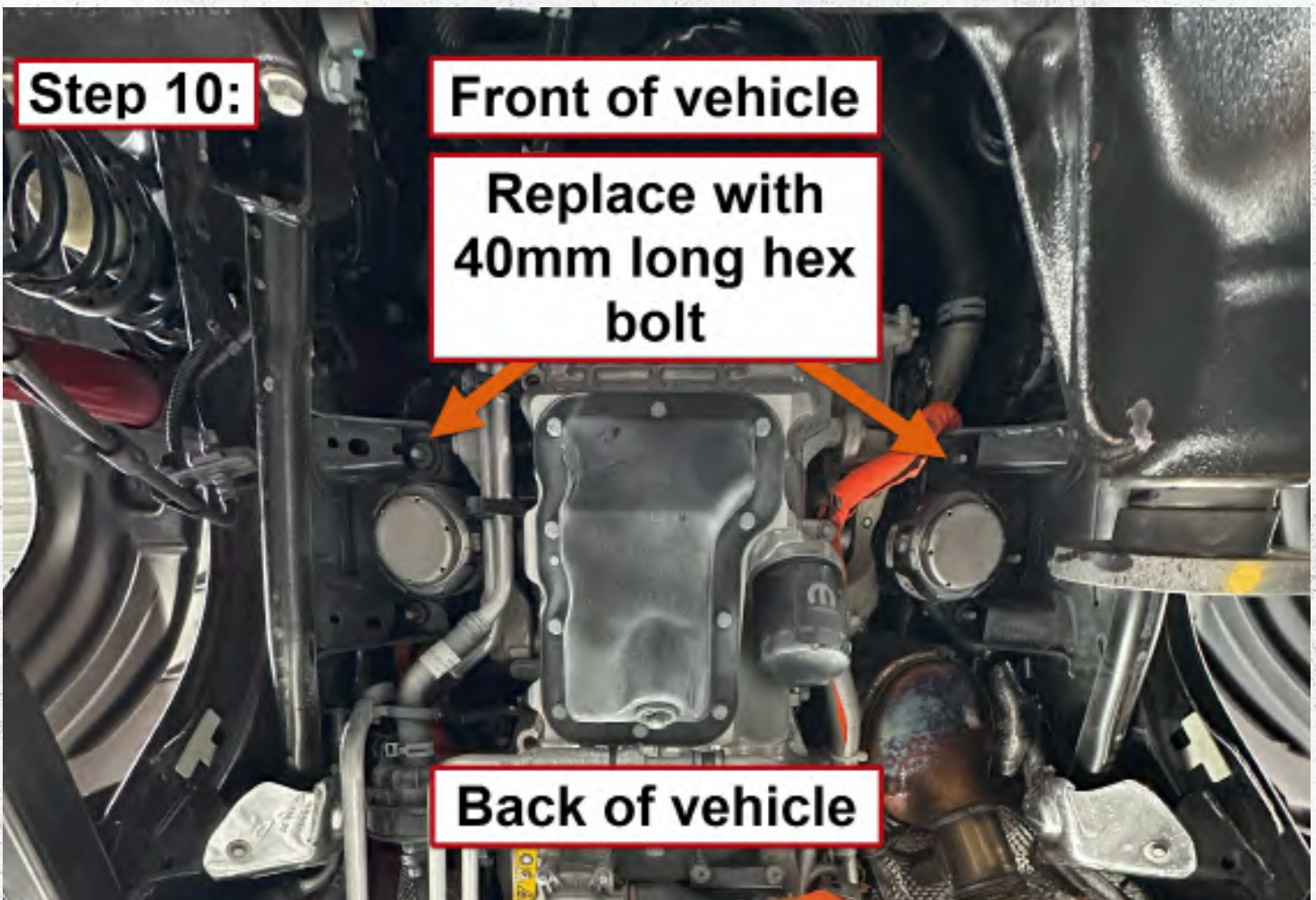

Step 10:

Front of vehicle

**Replace with
40mm long hex
bolt**

Back of vehicle



Step 9:

Install the new 40mm long hex bolt with zinc washer. This bolt replaces the factory bolt which can be removed using a 13mm wrench. **Replace the bolt closest to the front of the vehicle on the passenger and driver side of the vehicle.**

On both sides of the vehicle, tighten the new 40mm long hex bolt fully using a 17mm wrench.

Detailed view above



**Passenger
front**

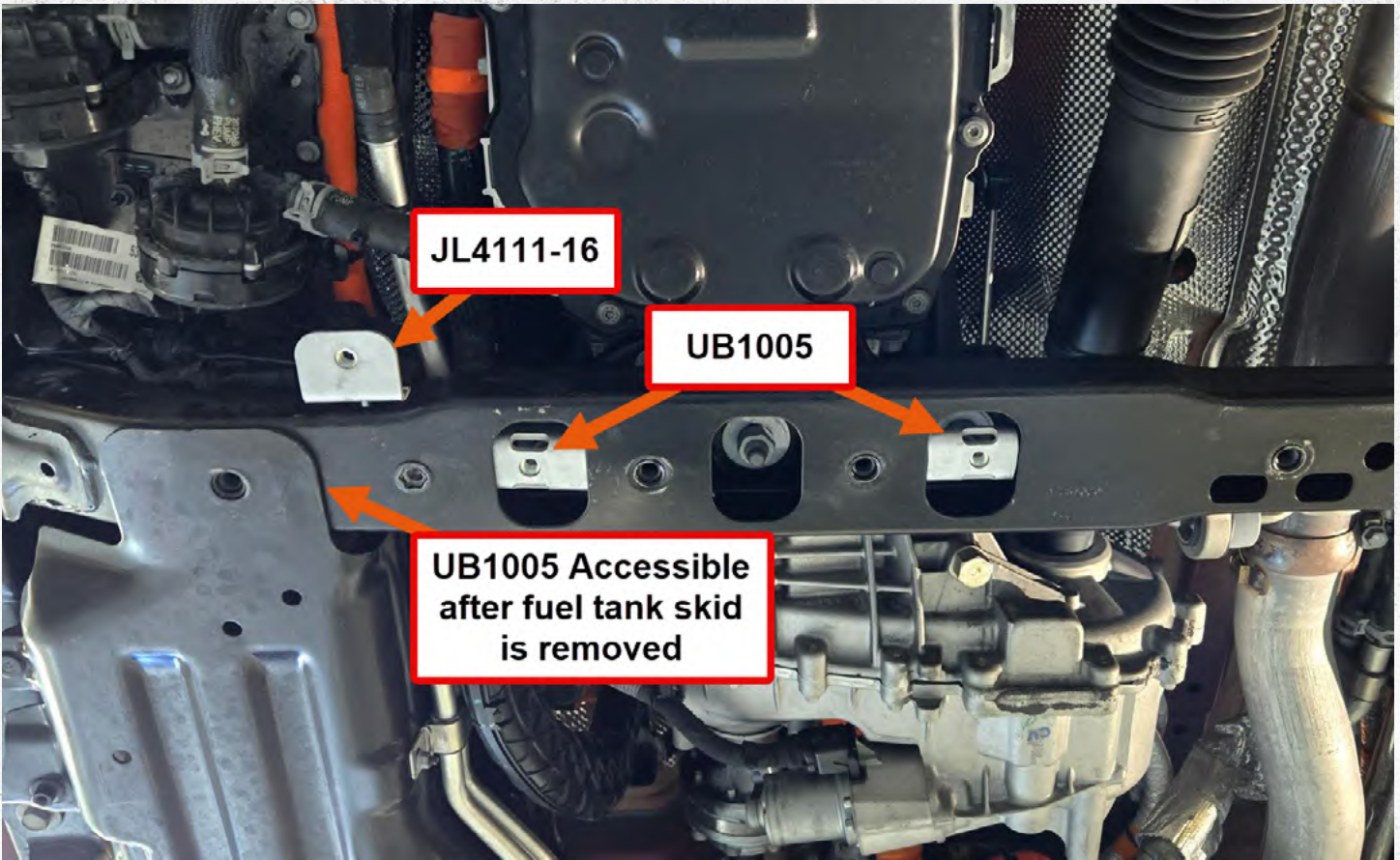

Step 10:
Insert the three **UB1005** nut plates into the cross member.

The left most UB1005 bracket is accessible after the removal of the fuel tank skidplate.

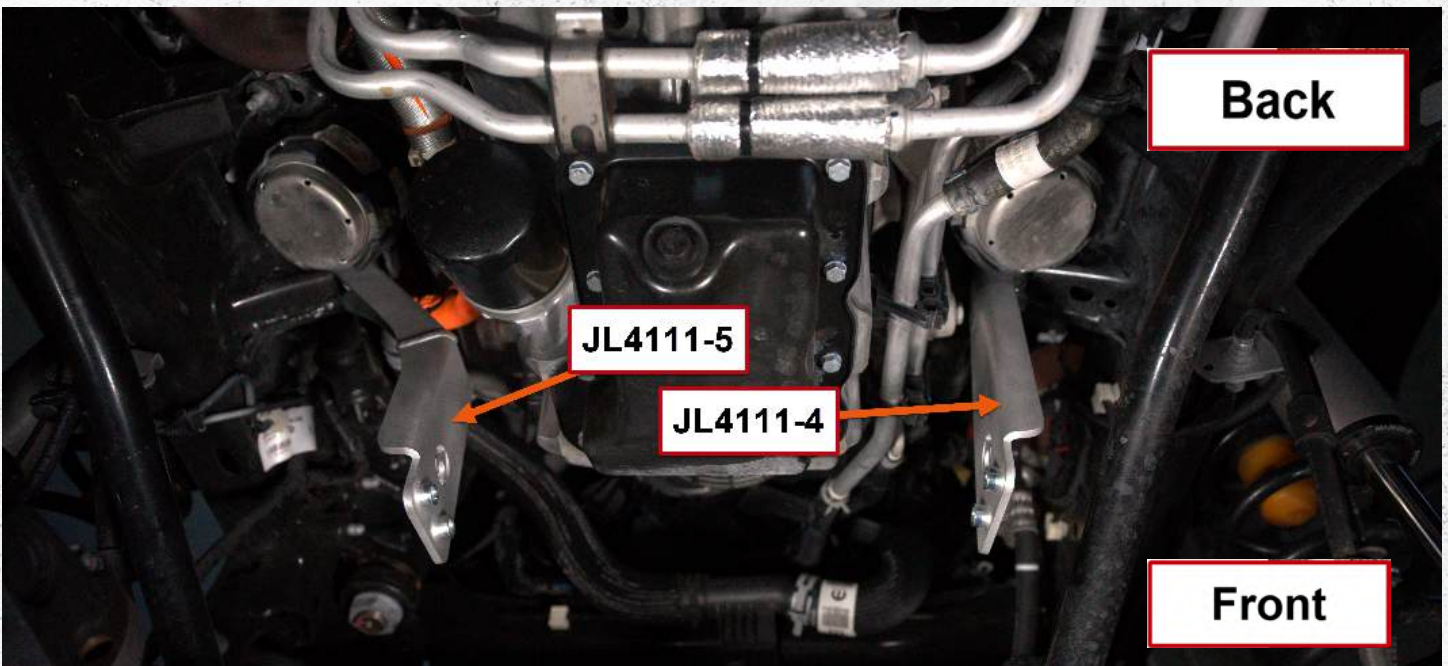

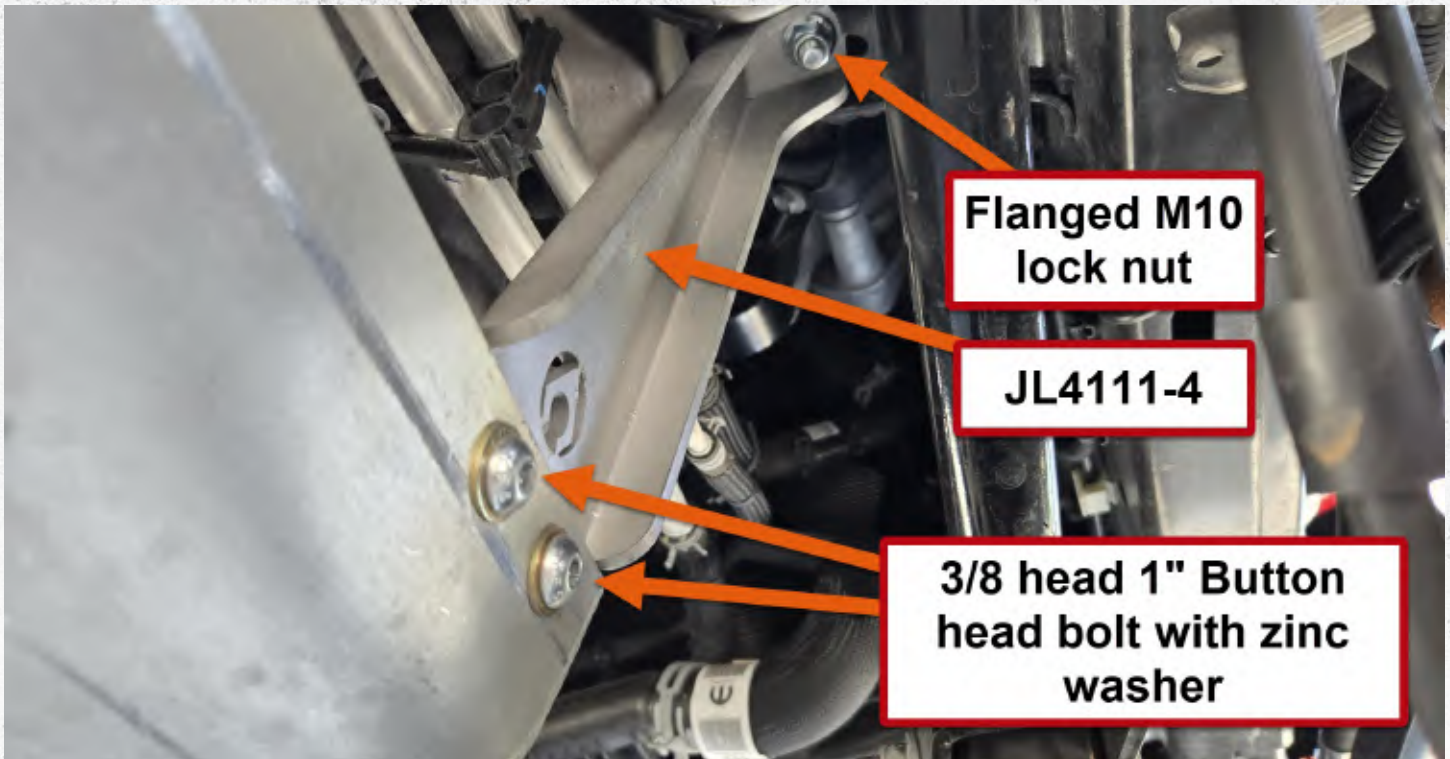

Step 11:

Install the skid plate onto the motor mount brackets using a m10 flag nut and twp 3/8" 1" button head bolts with zinc washers on both sides.

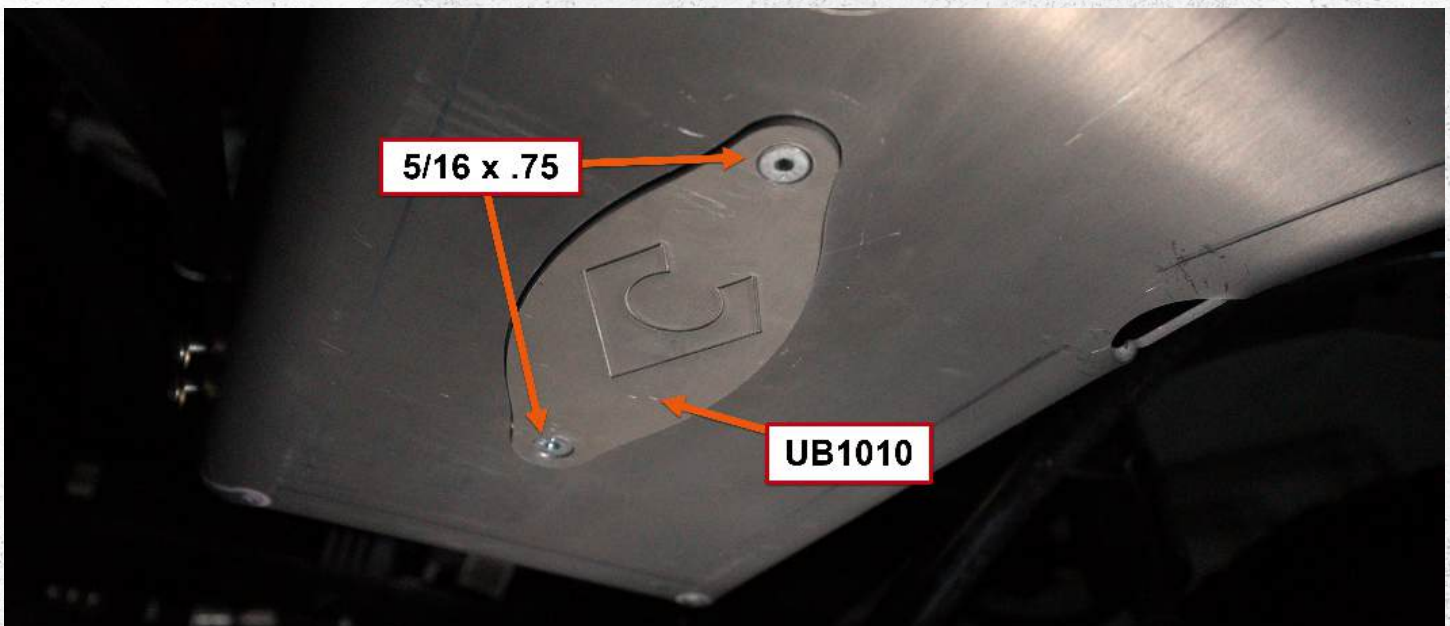

Step 12:

Install the oil door **UB1010** using two 5/16" x .75 inch countersunk bolts using a 5/16 hex bit.

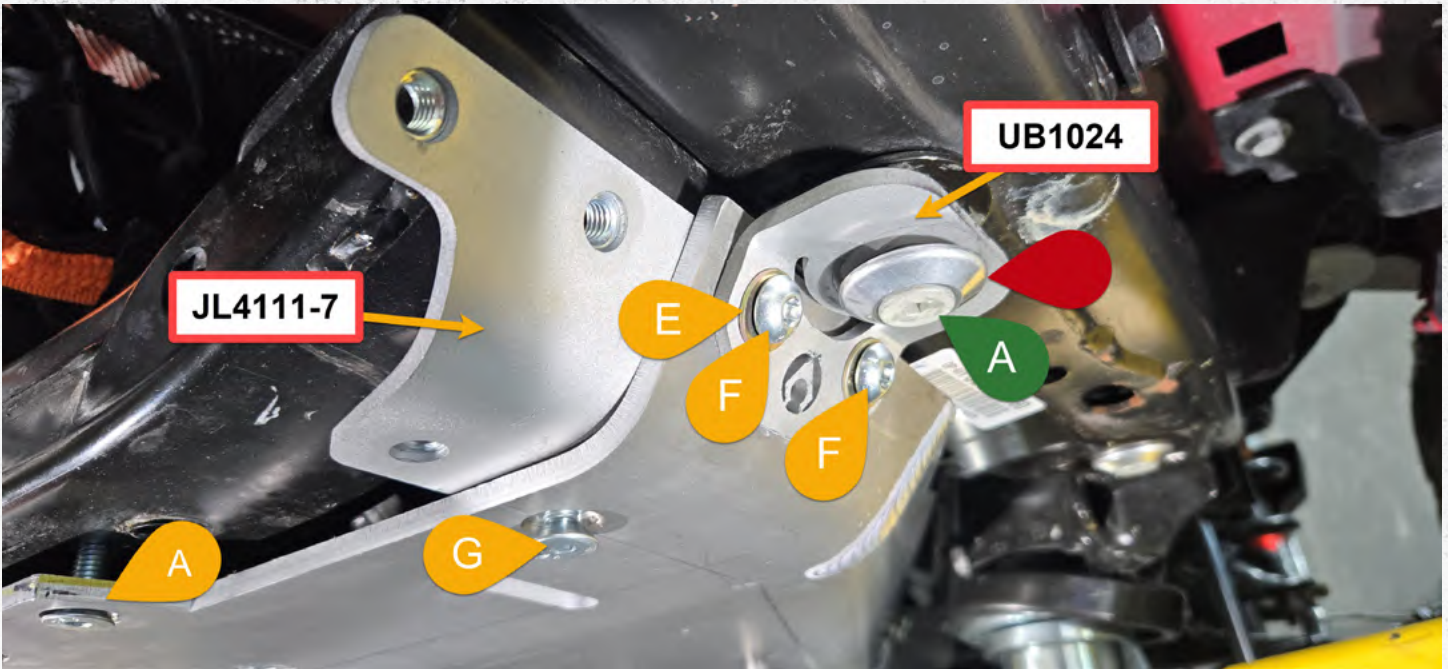

Step 13:

Install the hardware as follows including sliding **JL4111-7** into the engine skid with **UB1024** on the outside.

RED Aluminum washer

GREEN A 40mm M12 countersunk bolt

Yellow A 3/8x 1.5" countersunk bolt

Yellow B 3/8x 1" countersunk bolt

Yellow E 3/8" zinc washer

Yellow F 3/8 x 1" Button head screw

Yellow G 3/8 x .75 countersunk bolt

All hardware will remain loose until the end of installation.

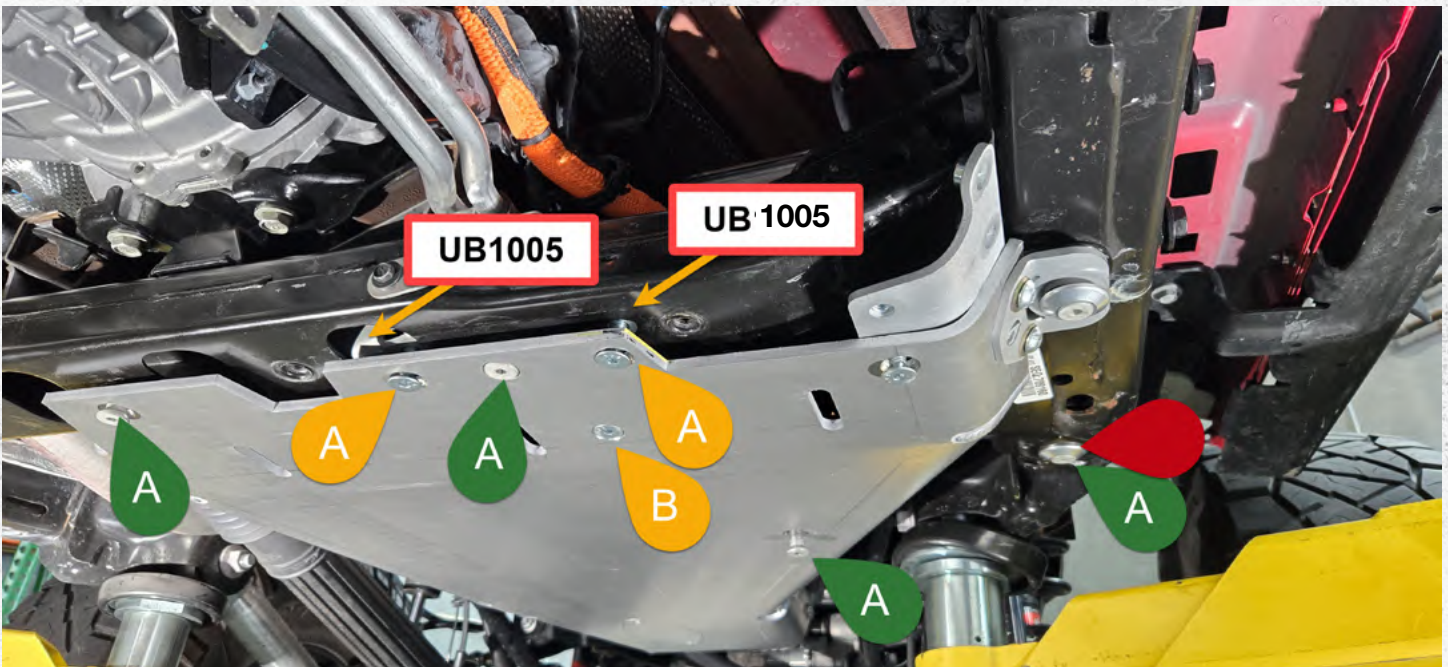

FACTORY FUEL TANK SKID REMOVAL

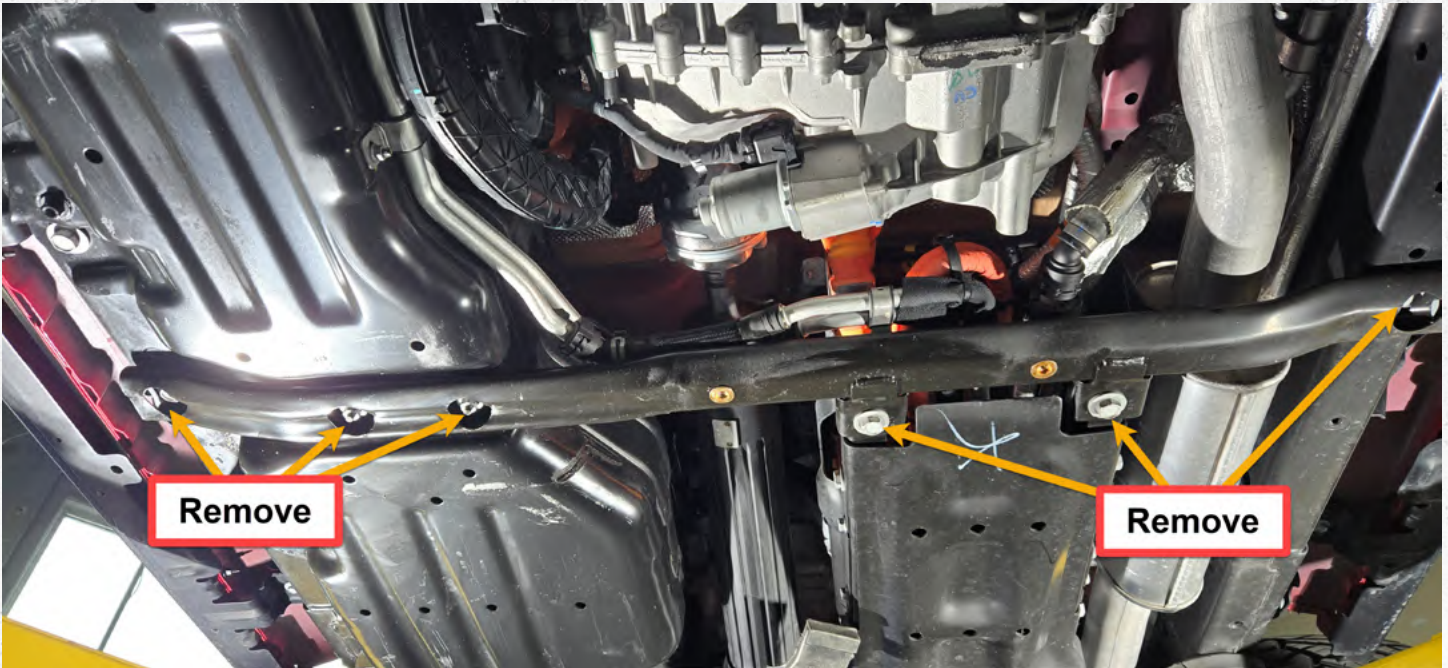

Step 14:

Remove the factory brace by uninstalling 6 factory bolts using a 18mm and 16mm socket.

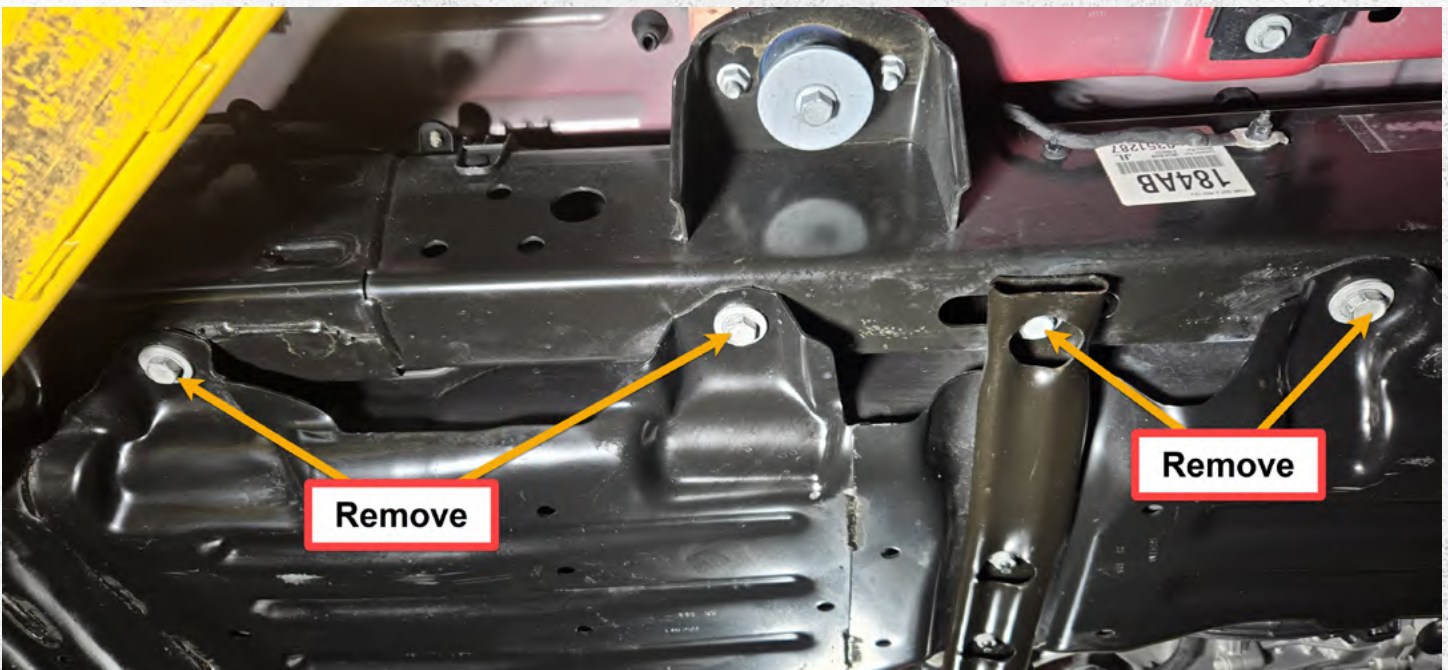

Step 15:

Lower the fuel tank by removing these 4 18mm factory bolts.

FACTORY FUEL TANK SKID REMOVAL

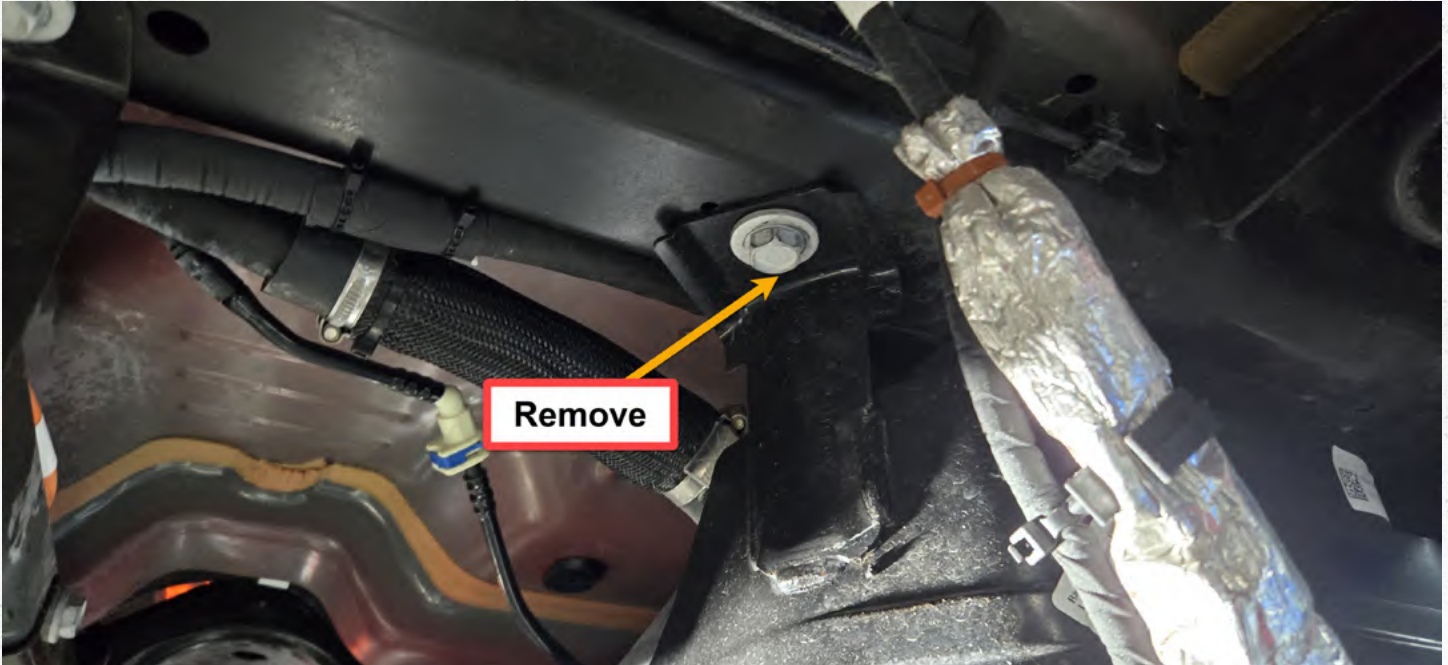

Step 16:

Remove and keep the factory 18mm bolt from the back of the fuel tank skid-plate.



Step 17:

Remove and keep the factory 18mm bolt from the back of the fuel tank skid-plate closest to the passenger side.

FACTORY FUEL TANK SKID REMOVAL



Step 18:

Remove and keep the two factory 10mm head bolts for installing the fuel tank skid-plate.

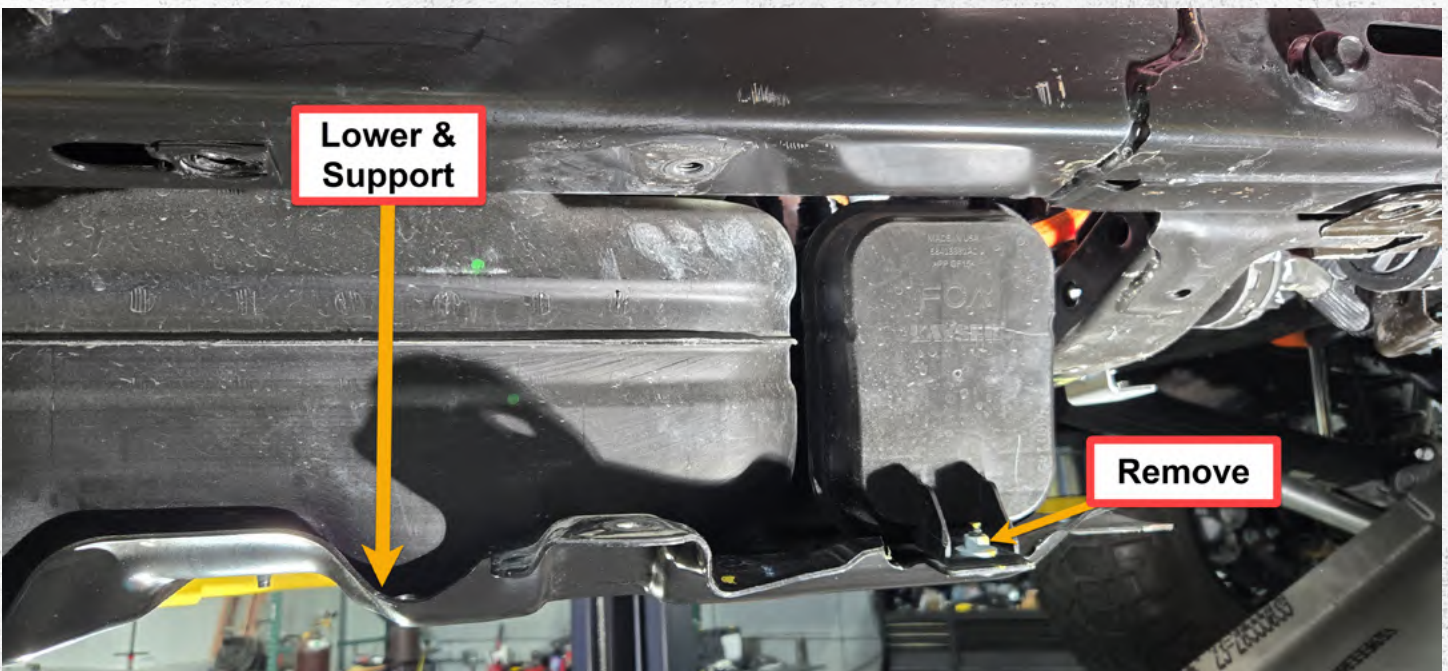

Step 19:

Using a jack or other supporting device, slowly lower the fuel tank skid to access the factory EVAP unit.

Slide a ratchet strap in between the fuel tank and skid-plate to support the fuel tank during installation of the new fuel tank strap and skid-plate.

FACTORY FUEL TANK SKID REMOVAL

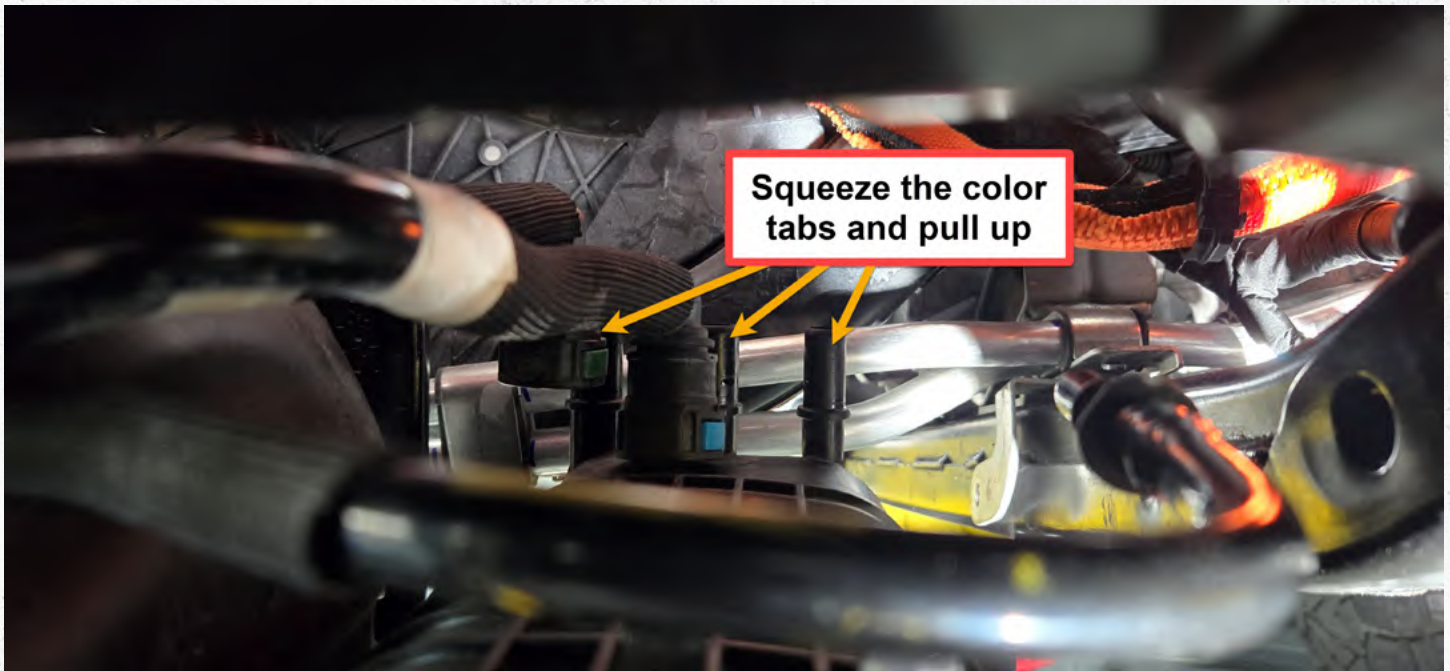

Step 20:

With the fuel tank lowered you will now be able to access and remove the 3 hoses connected to the EVAP cannister.



Step 21:

Remove the 3 factory bolts securing the EVAP cannister to the factory fuel skid-plate.

FACTORY FUEL TANK SKID REMOVAL

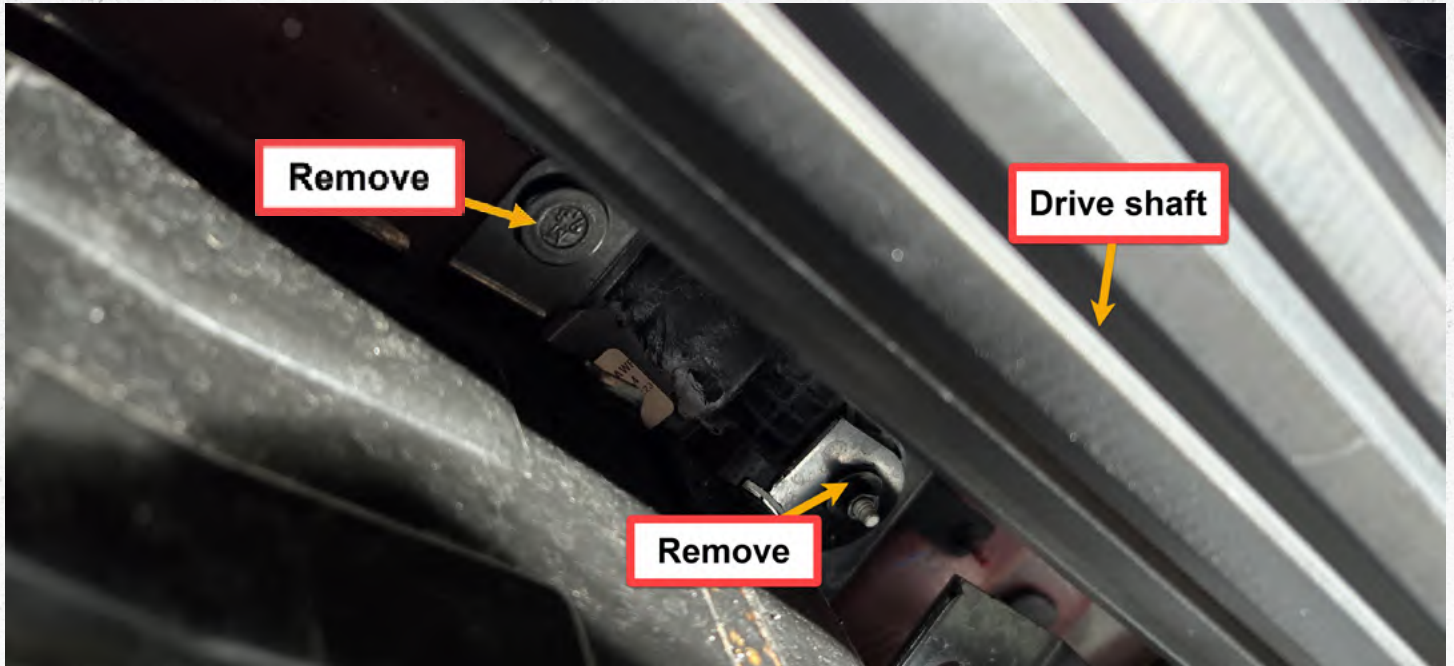

Step 22:

Remove 10mm bolt shown bottom right, remove 10mm nut top left.

FUEL TANK & T-CASE SKID INSTALL

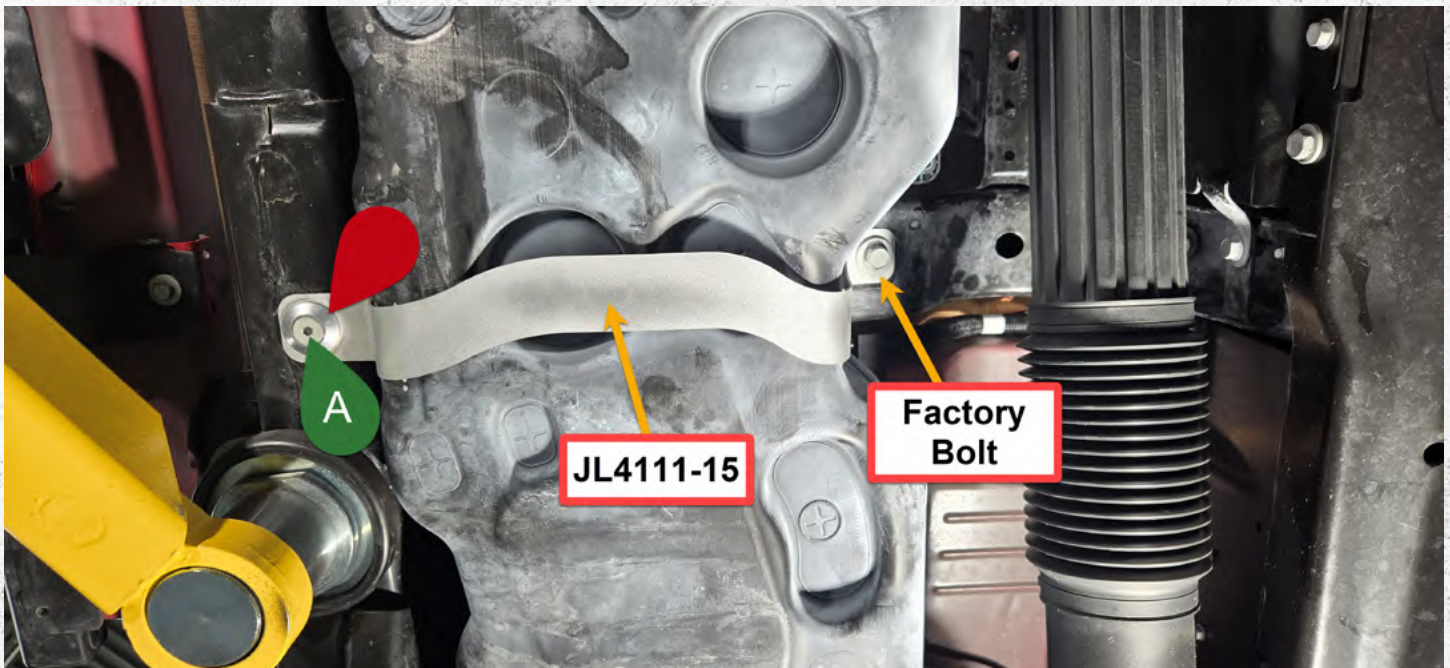

Step 23:

Install **JL4111-15** to secure the fuel tank using a 18mm head factory bolt and the provided m12 countersunk bolt with aluminum washer.

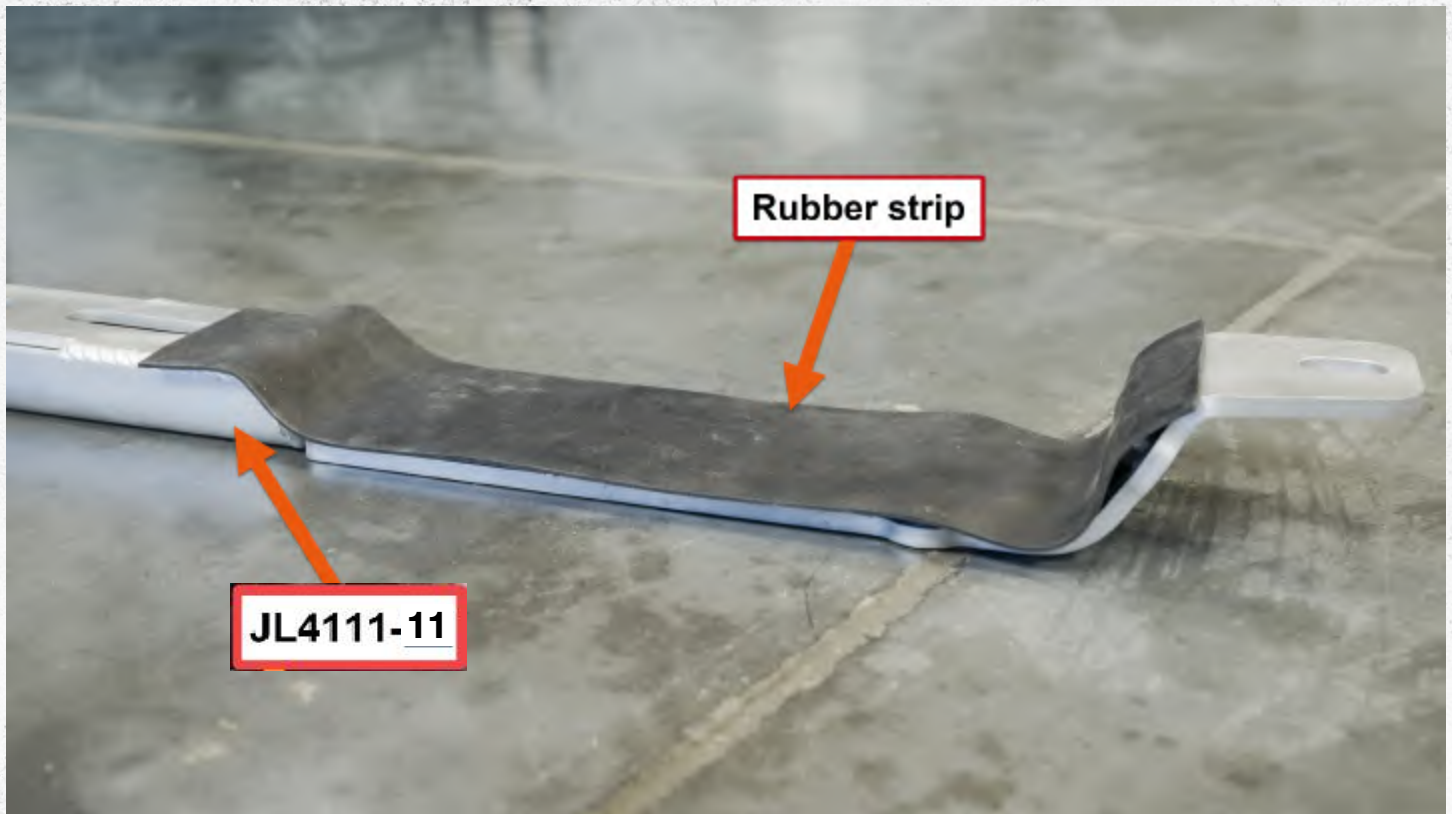

Step 24:
Install the provided rubber stripping onto **JL4111-11**.

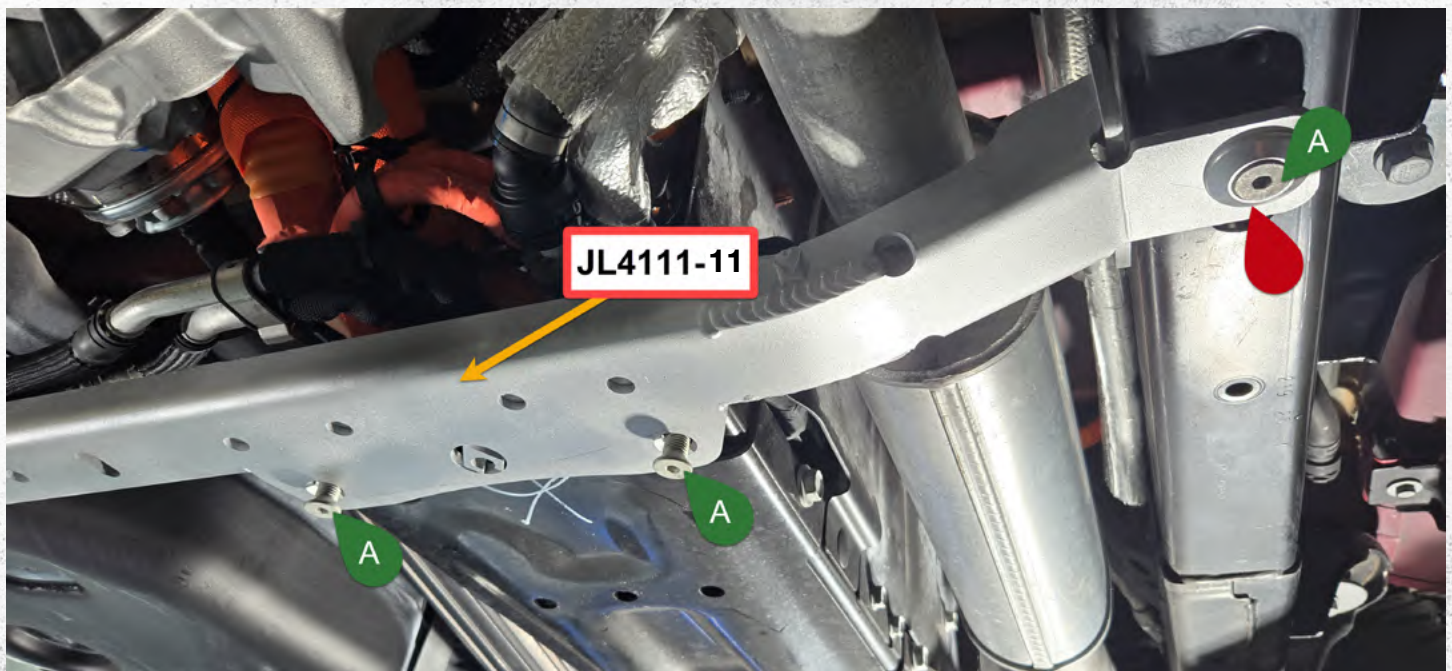

Step 25:
Install **JL4111-11** using four M12 countersunk bolt and 2 aluminum washers to hold the new cross-member into place.

FUEL TANK & T-CASE SKID INSTALL

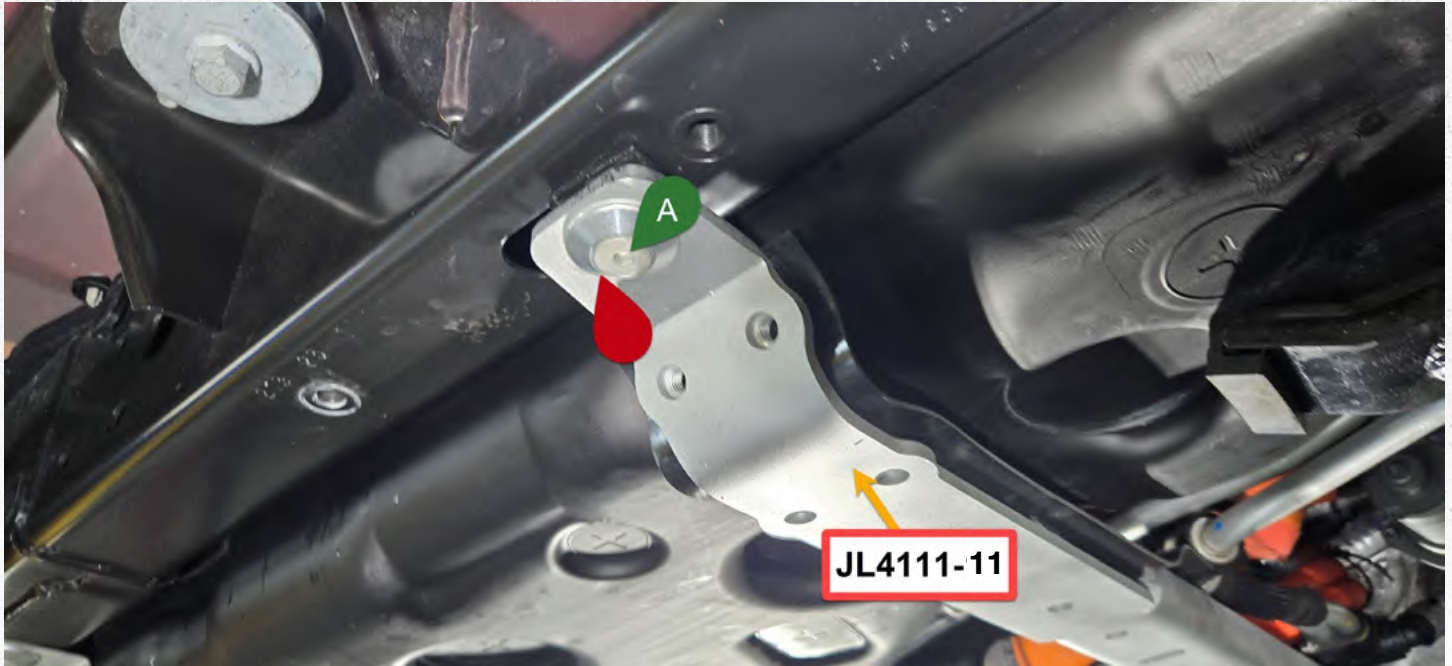

Step 25: (Re-stated)

Install **JL4111-11** using four M12 countersunk bolt and two aluminum washers to hold the new cross-member into place.

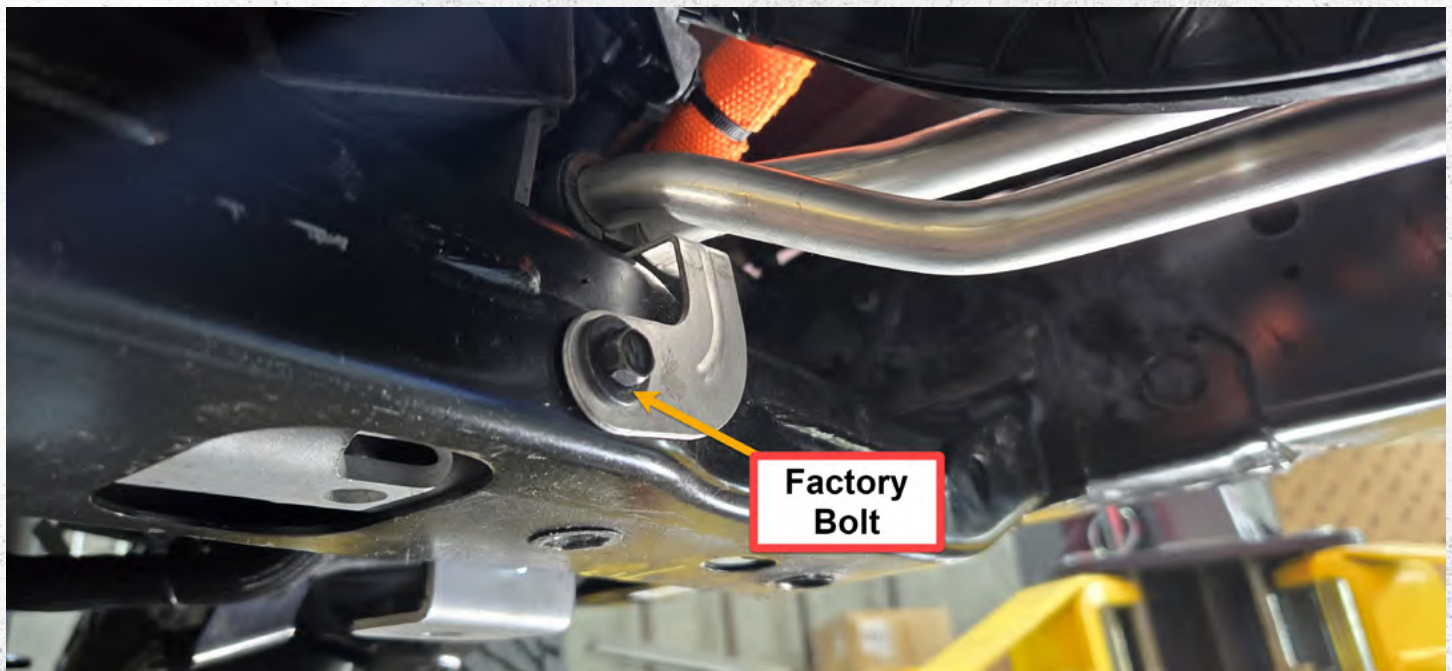

Step 26:

Reinstall the factory 10mm head bolt to secure the lines.

FUEL TANK & T-CASE SKID INSTALL

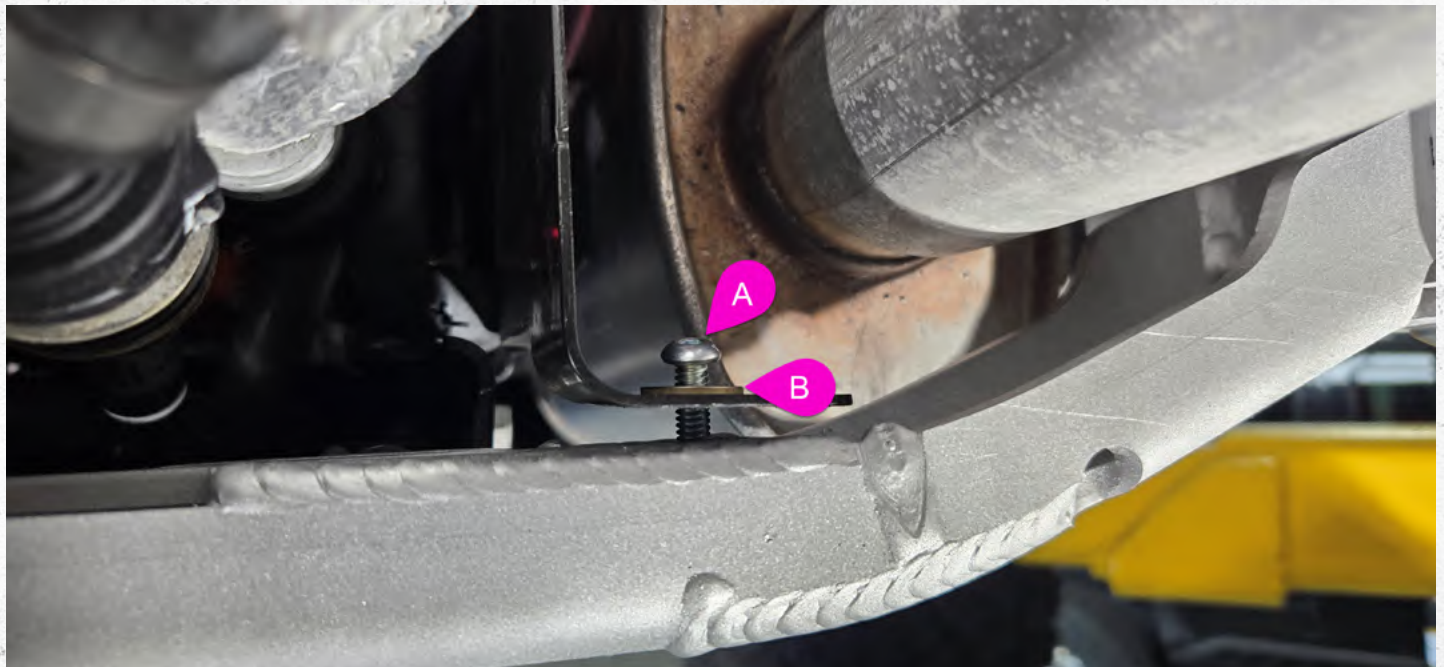
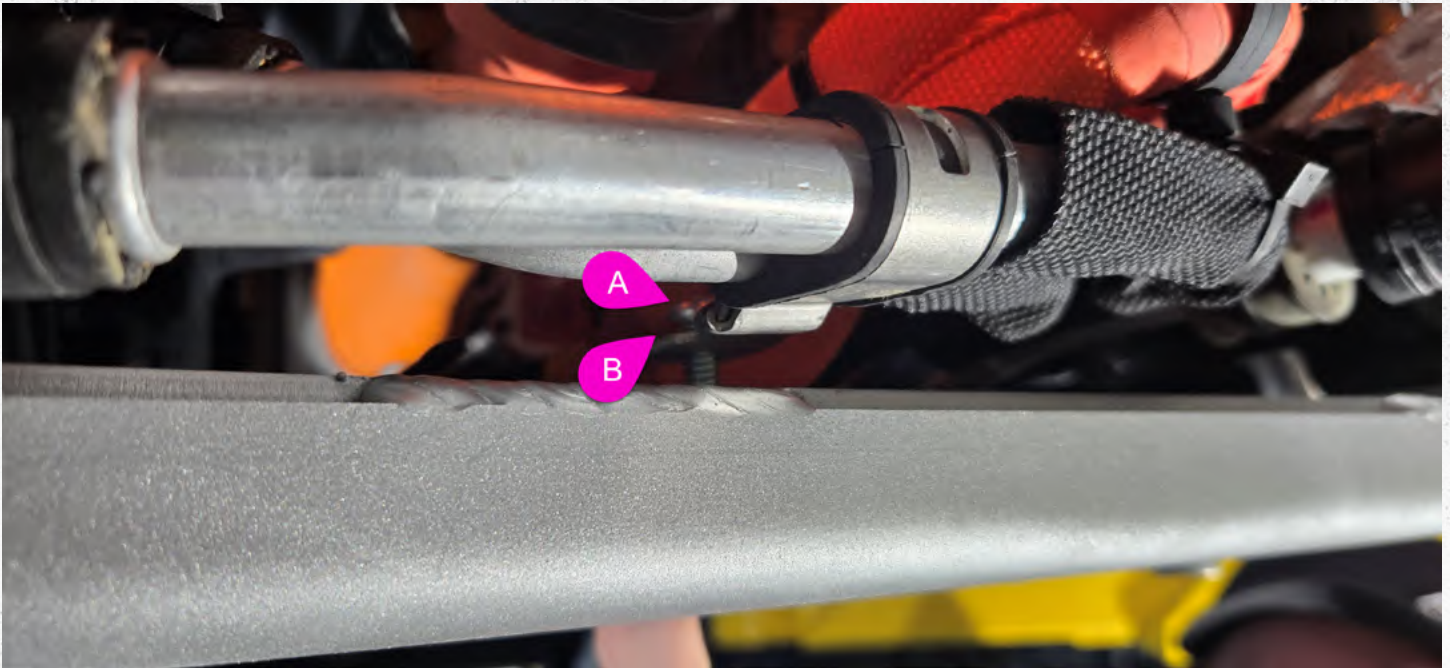

Step 27:

Using two 1/4" x 3/4" button head screws with zinc washers, secure the lines to the new **JL4111-11** cross-member.

T-CASE SKID PRE-INSTALL

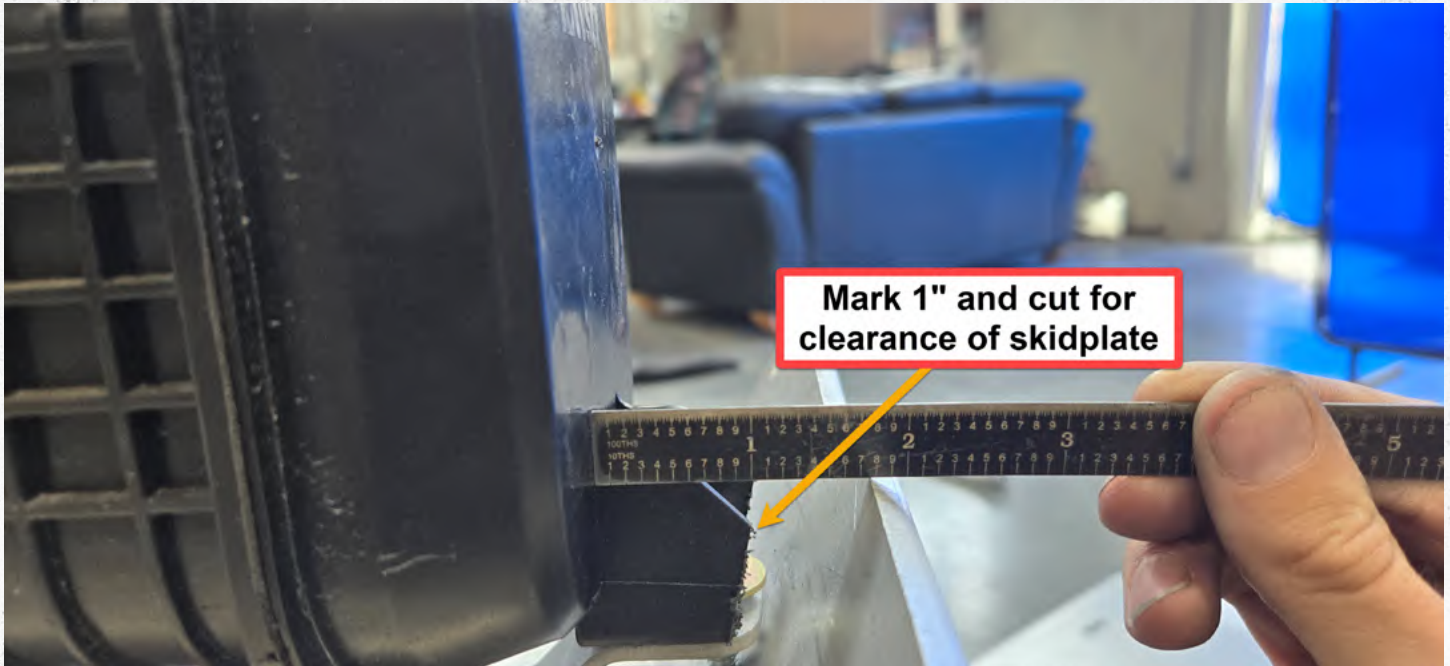

Step 28:

Using a ruler, mark 1" from the face of the EVAP cannister and cut the material to clearance for the transfer case skid-plate.

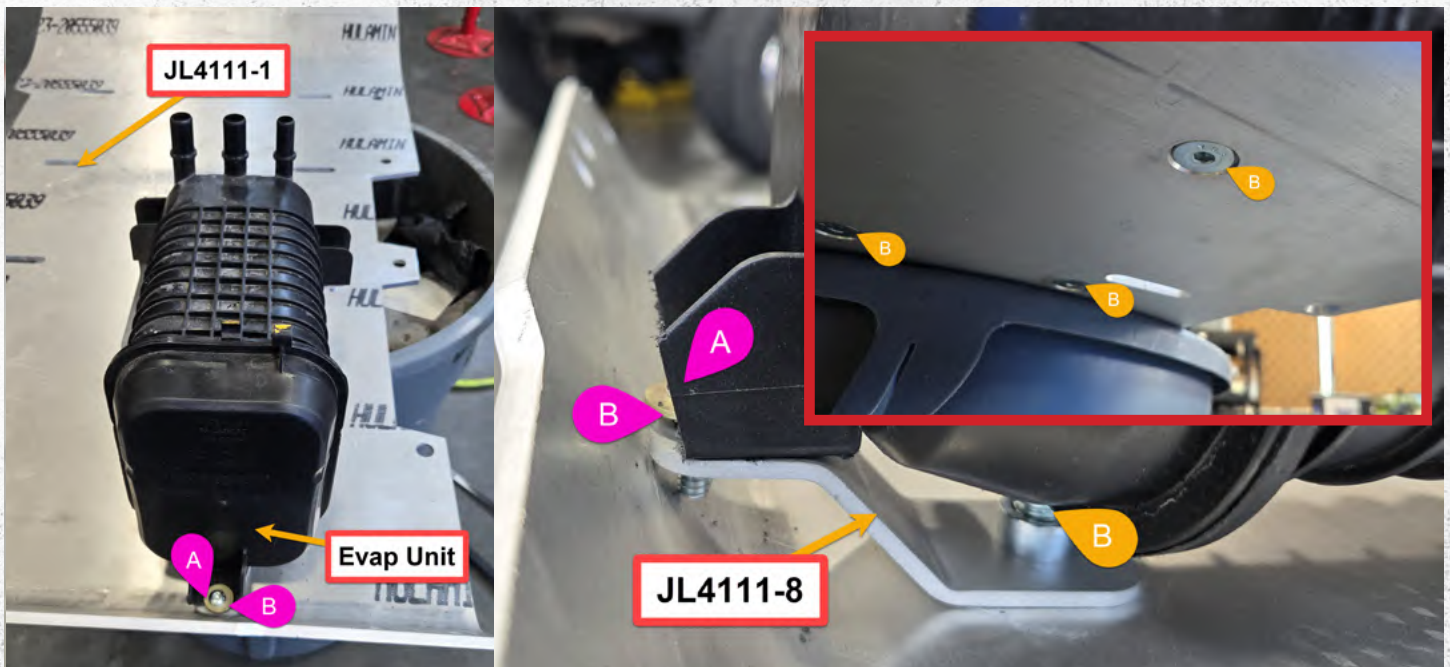

Step 29:

This step shows how to orient the **JL4111-8**, **JL4111-9**, and **JL4111-10** brackets on the EVAP cannister. The three countersunk 3/8" x 1" bolts indicated with the **yellow B** marker should be snug. The three 1/4" x 3/4" button head bolts with washers are indicated in pink and should be tightened fully.

Do not use power tools here!!! Using power tools can over-tighten and crack the plastic housing.

FUEL TANK & T-CASE SKID INSTALL

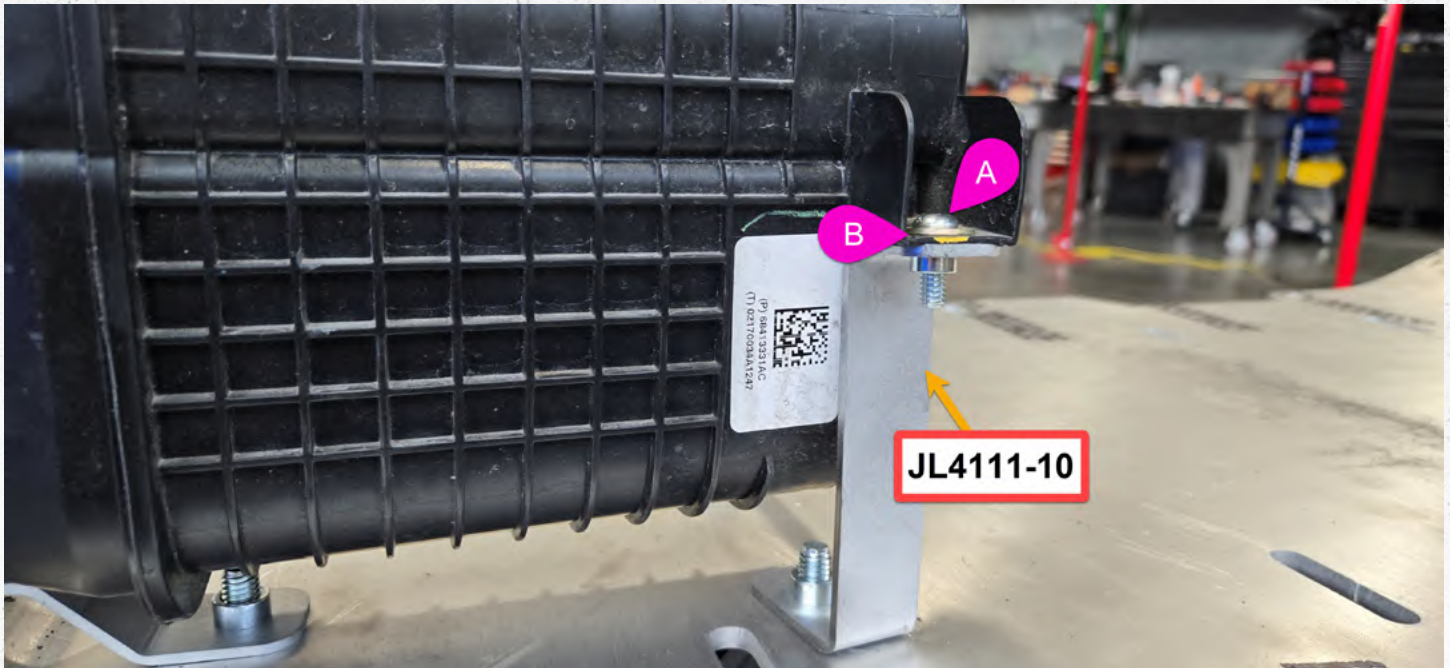

Step 30:
Installed 1/4" x 3/4" hardware using **JL4111-10**

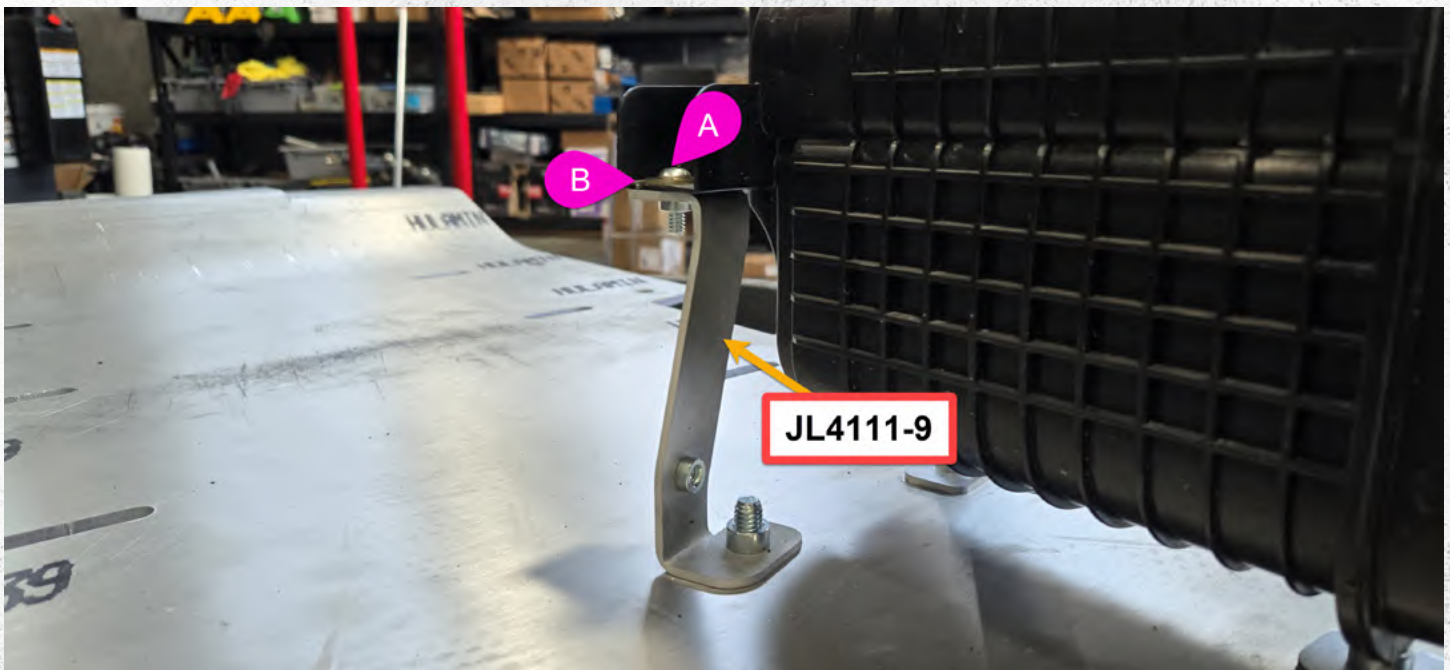

Step 31:
Installed 1/4" x 3/4" hardware using **JL4111-9**

NOTE!!! The orientation of JL4111-9 is important! This is where your factory coolant lines will be connected. See additional images on the next page.

FUEL TANK & T-CASE SKID INSTALL

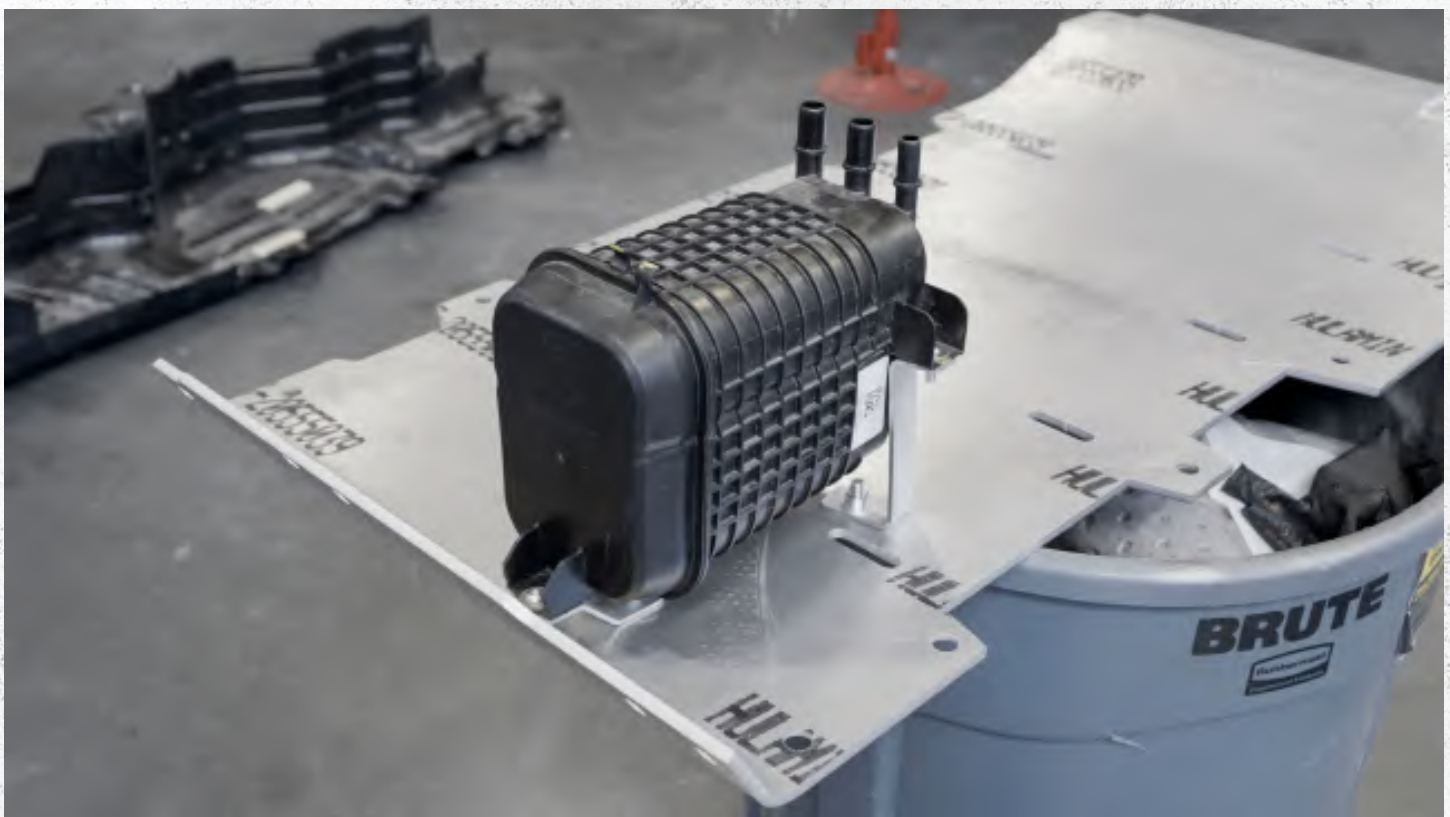
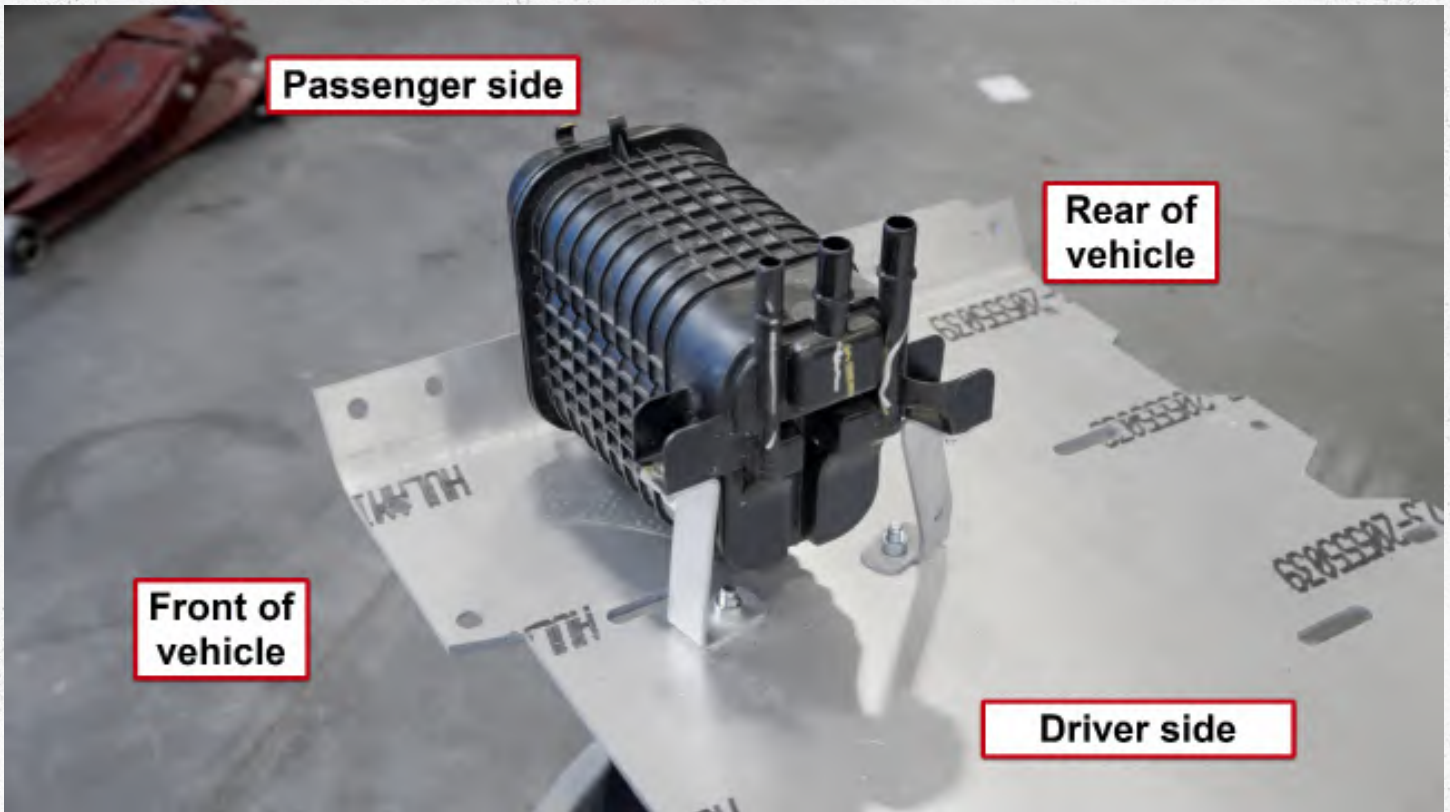

Additional images of step 28-31

FUEL TANK & T-CASE SKID INSTALL

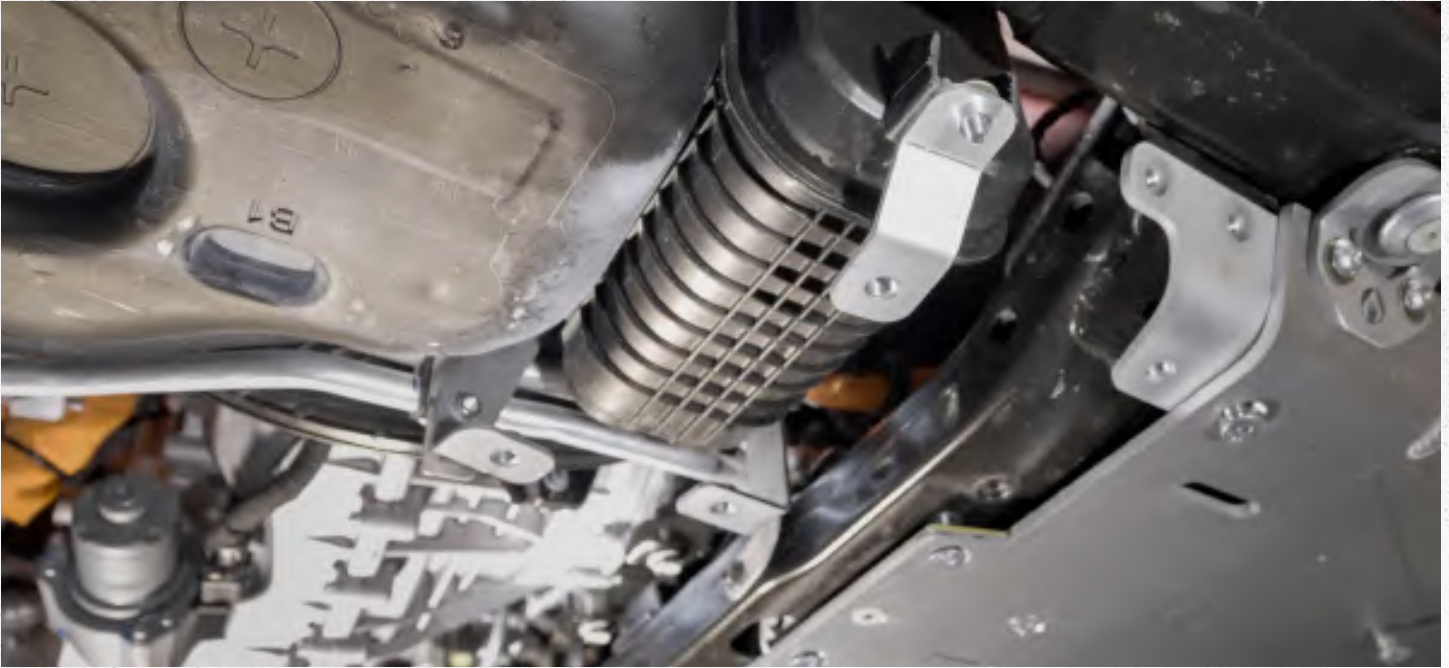

Step 32:

Remove the EVAP cannister with the brackets still attached and re install it into the vehicle.

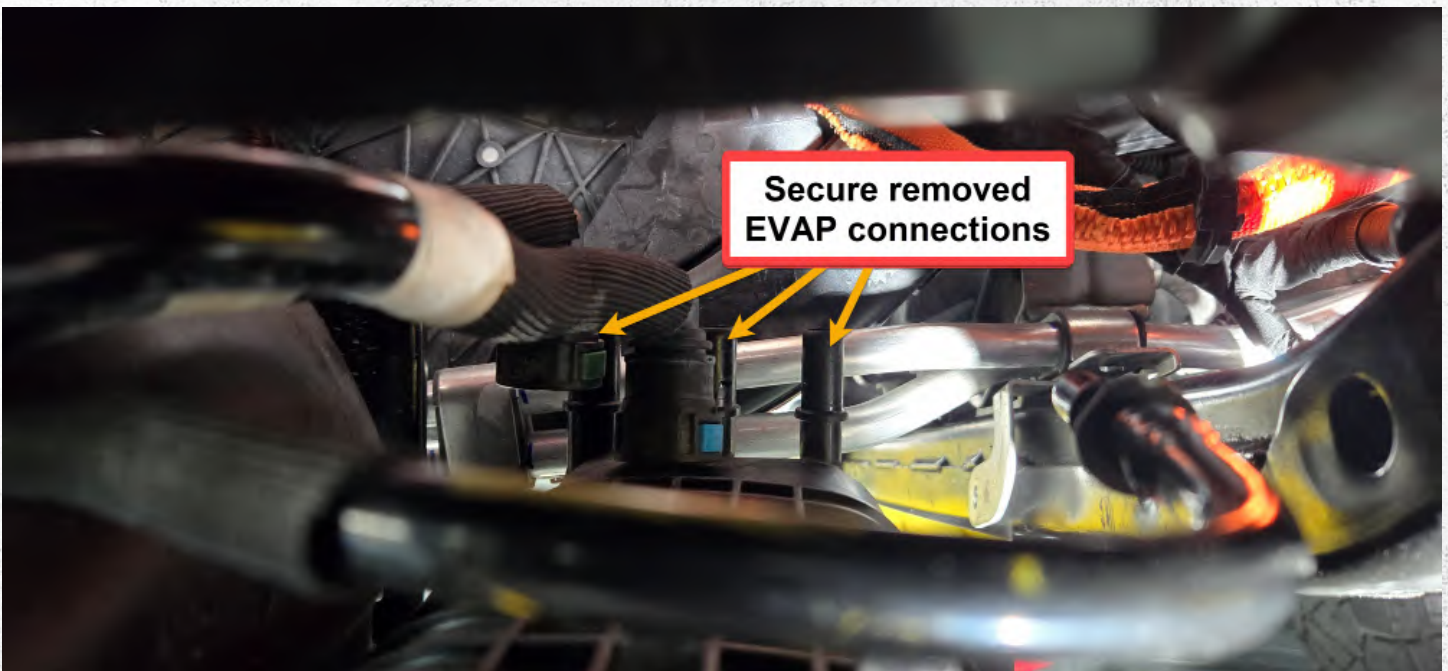

Step 33:

Re install the three removed hoses and install the Evap cannister separated from the transfer case skid-plate.

FUEL TANK & T-CASE SKID INSTALL

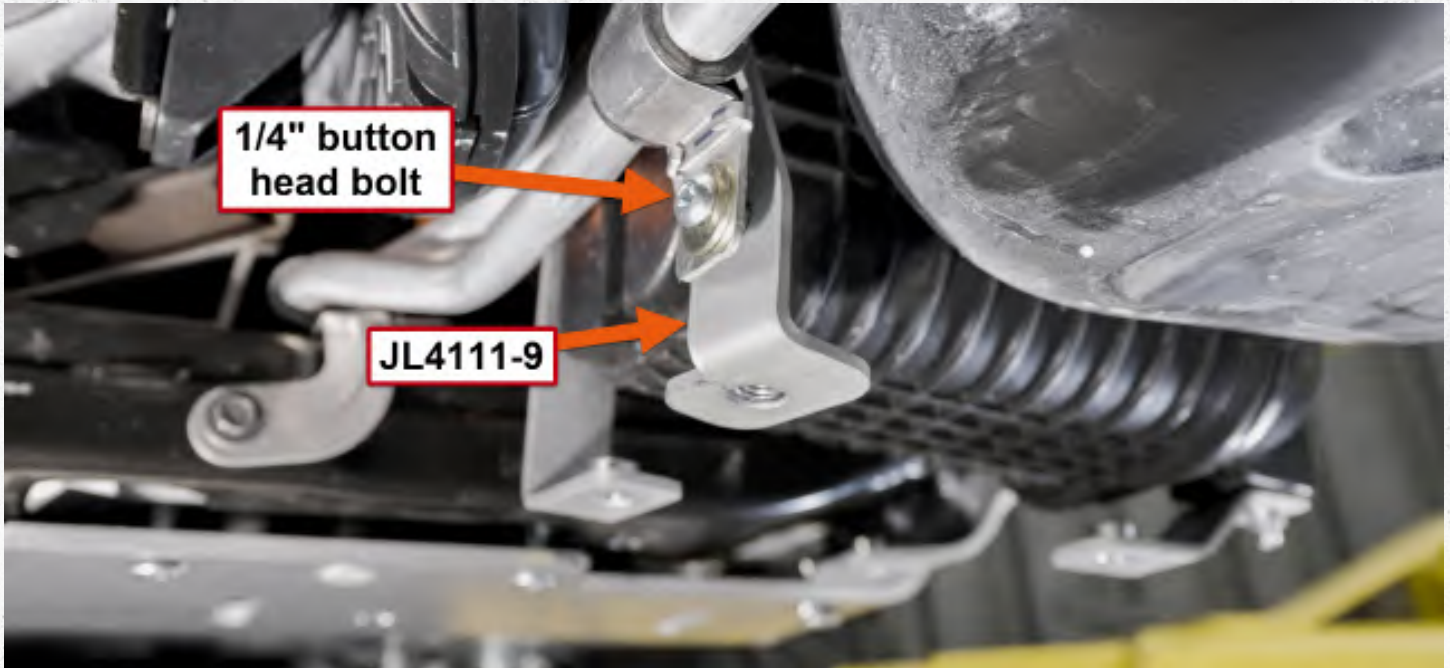

Step 34:

Install the factory coolant lines to bracket **JL4111-9** using a 1/4" x 3/4" button head bolt with zinc washer.

FUEL TANK & T-CASE SKID INSTALL

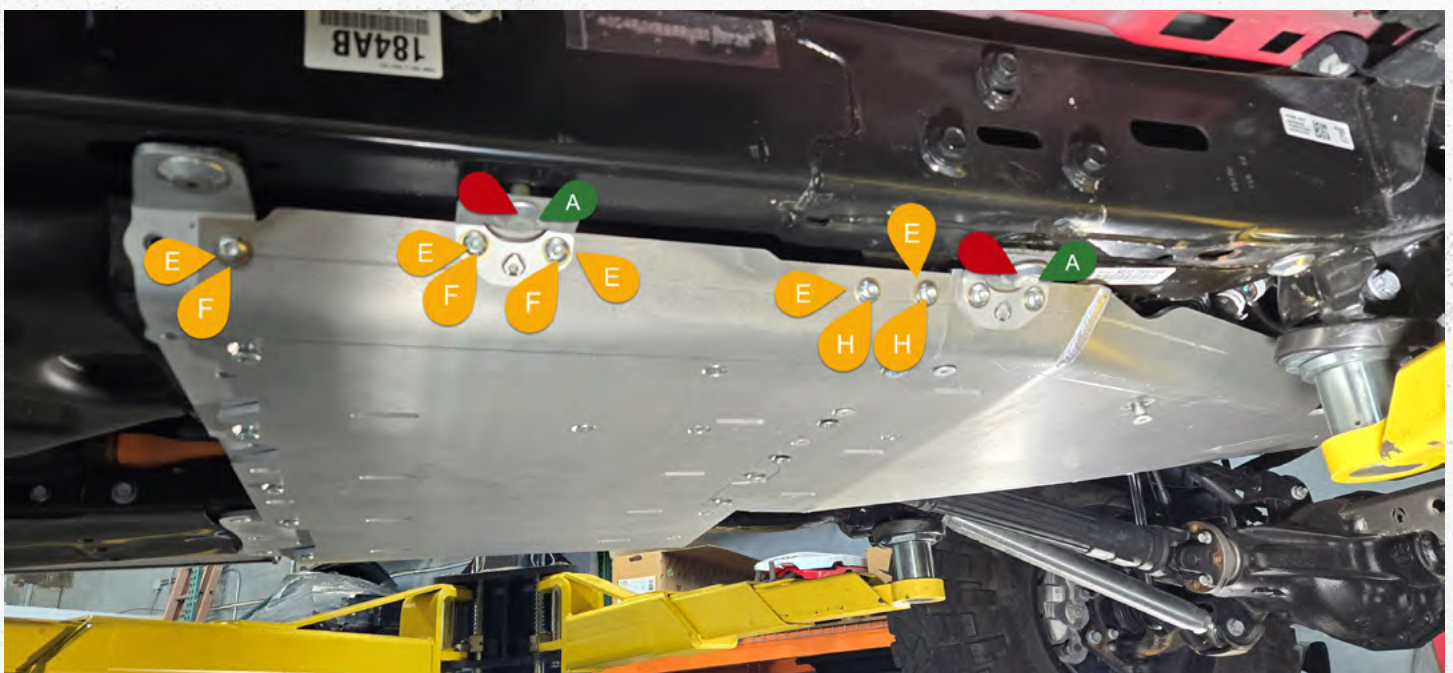
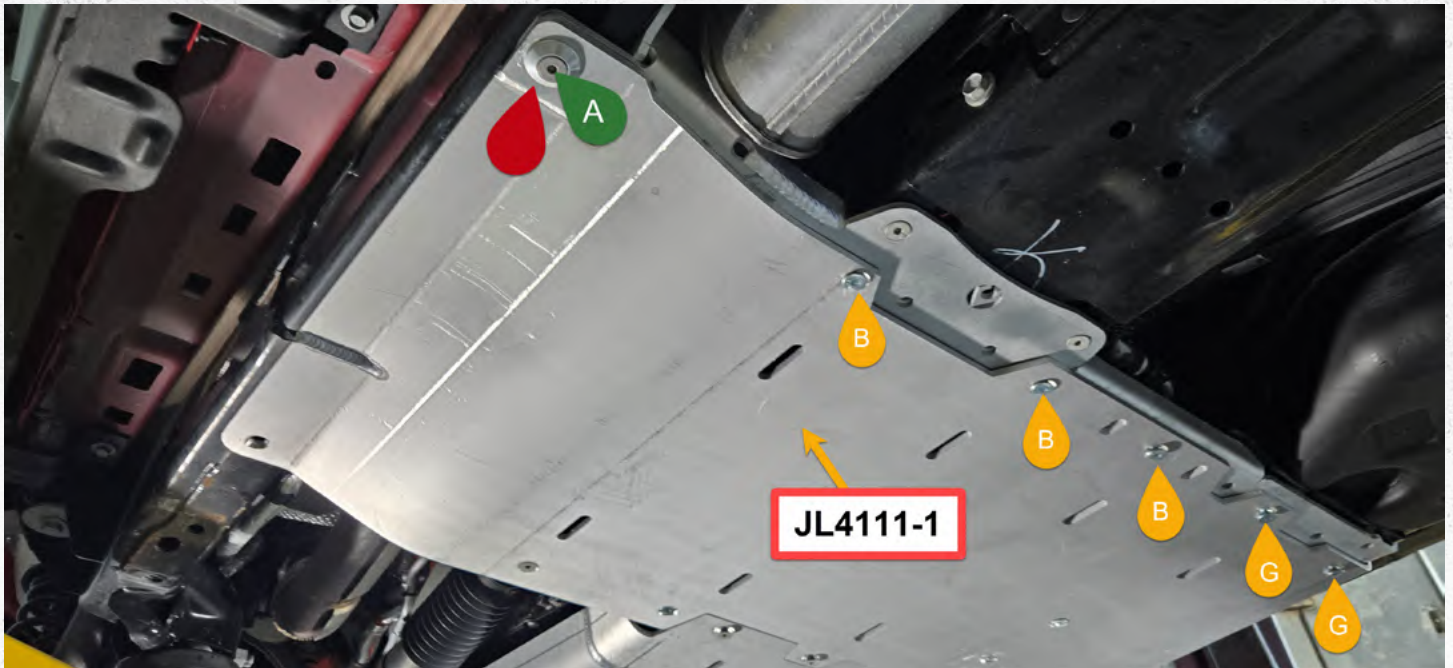

Step 35:

Install the hardware as follows.

RED Aluminum washer

GREEN A 40mm M12 countersunk bolt

Yellow B 3/8x 1 countersunk bolt

Yellow E 3/8 zinc washer

Yellow F 3/8 x 1 Button head screw

Yellow G 3/8 x .75 countersunk bolt

Yellow H 3/8 x .75 Button head screw

All hardware will remain loose until the end of installation.

FUEL TANK & T-CASE SKID INSTALL

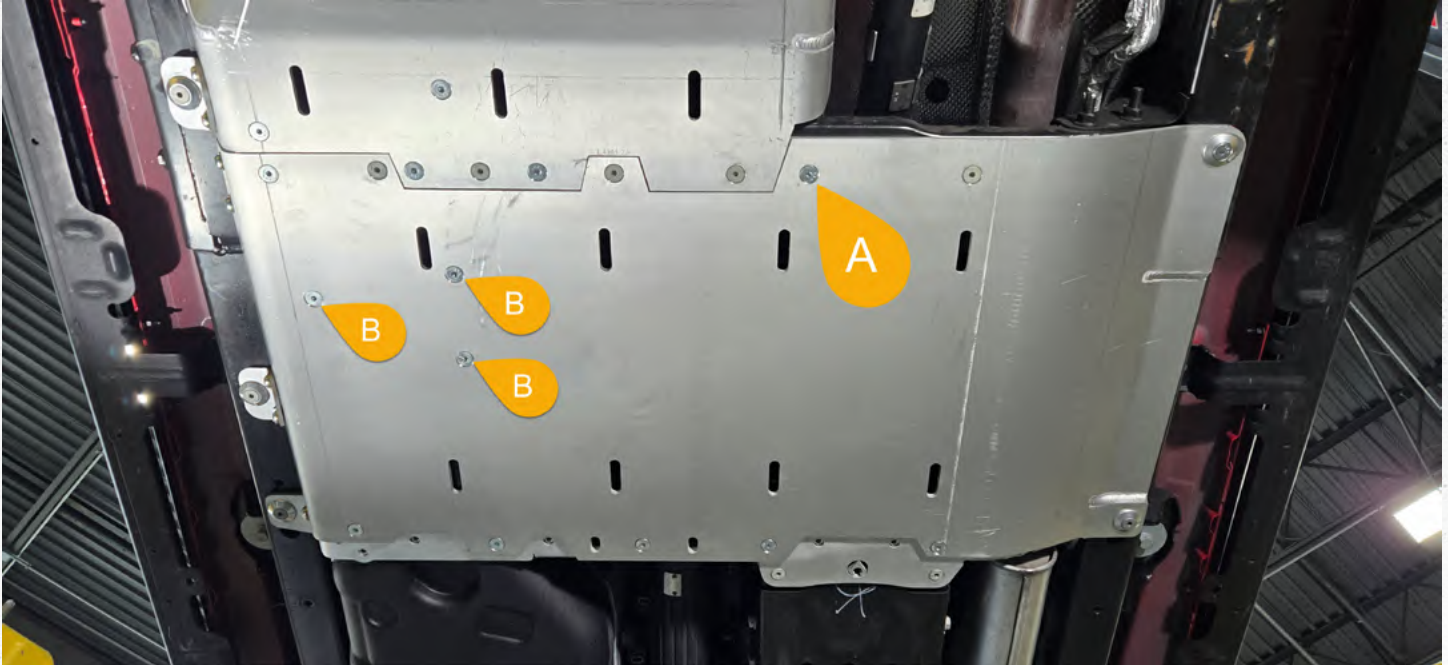

Step 36:

With the transfer case skid-plate loosely in place, install three 3/8" x 1" counter sunk bolts **Yellow B** to secure the EVAP cannister into place. These bolts should be tightened fully.

Install the 3/8" x 1.5" countersunk bolt **Yellow A**.

FUEL TANK SKID PRE-INSTALL

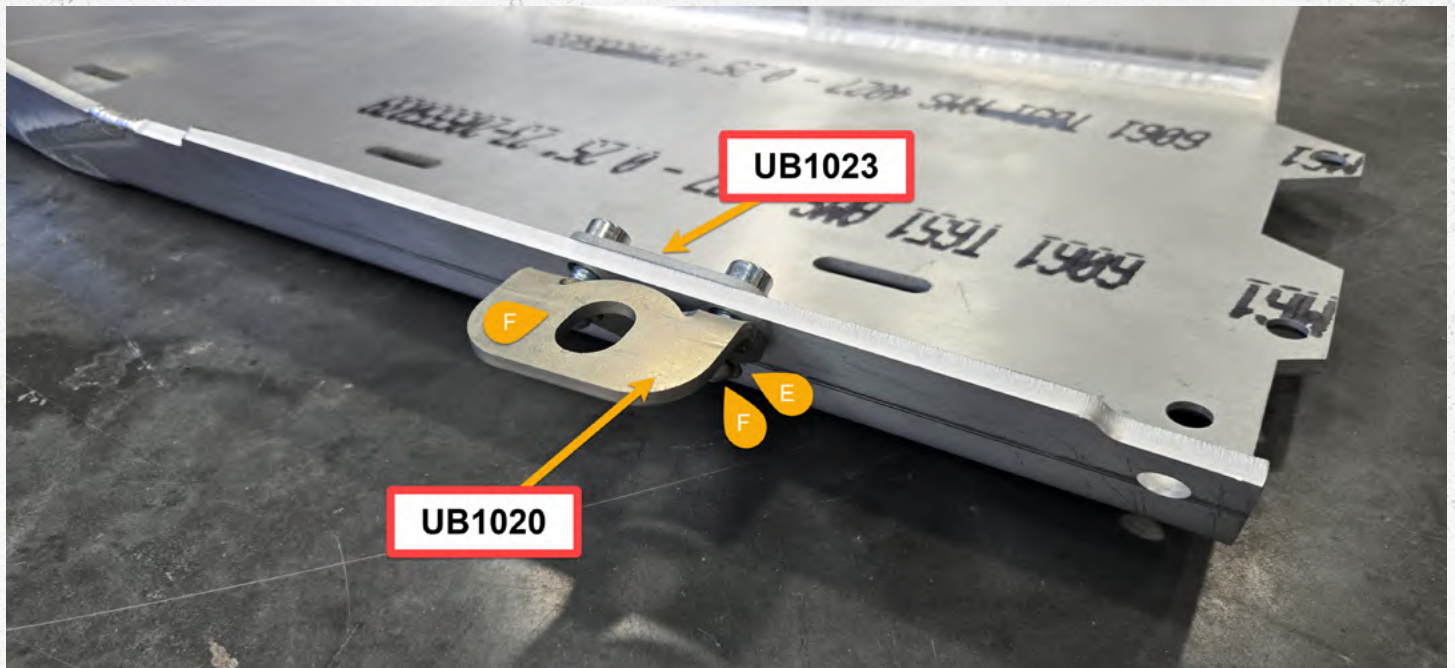

Step 37:

Install **UB1023** using **UB1020** with two 3/8" x 1" button head bolts with zinc washers.

All hardware should be installed loosely.

FUEL TANK SKID PRE-INSTALL

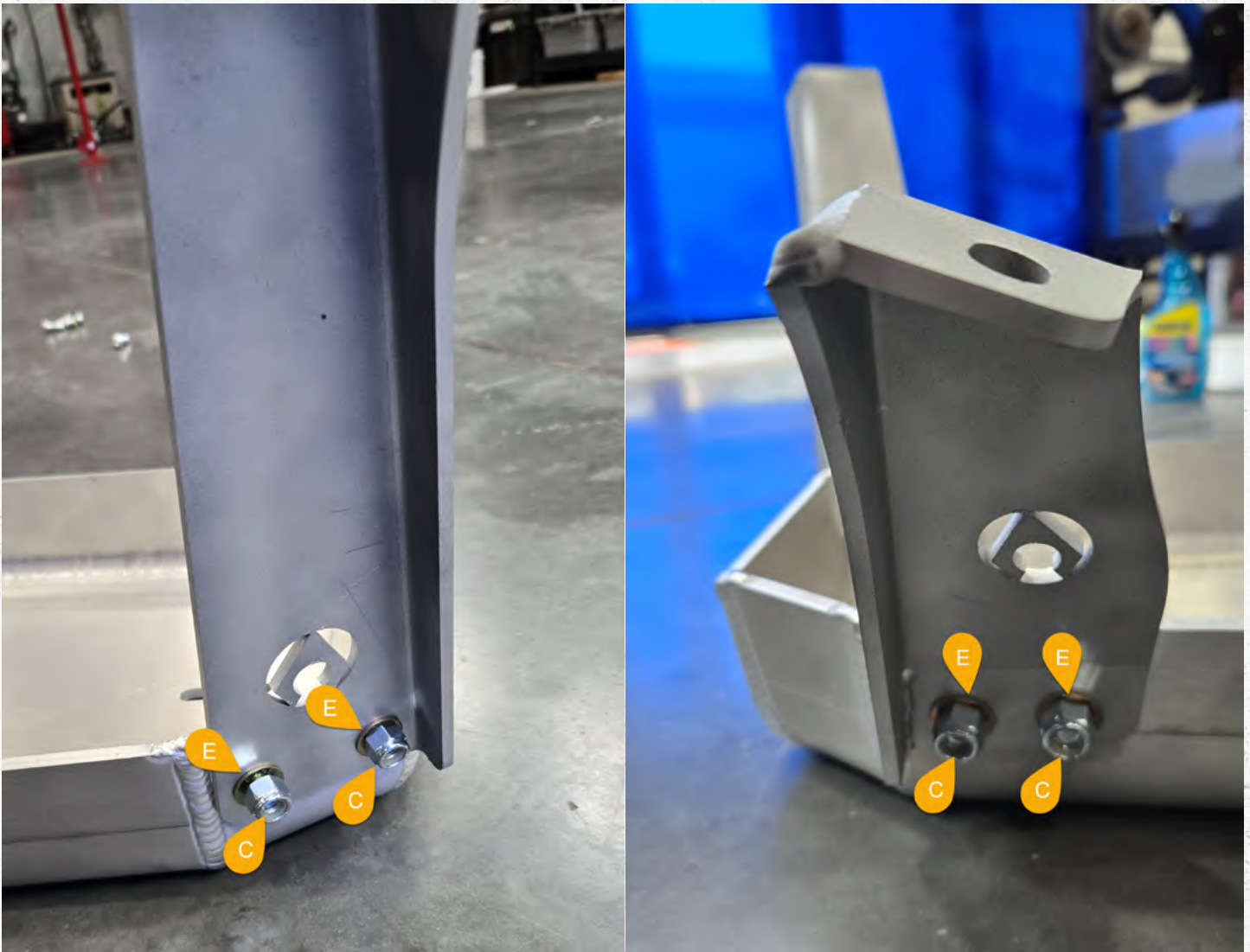

Step 38:

Image left:

Install **JL4111-14** using two 3/8" carriage bolts with two 3/8" nylon lock nuts and zinc washers.

Image Right:

Install **JL4111-13** using two 3/8" carriage bolts with two 3/8" nylon lock nuts and zinc washers.

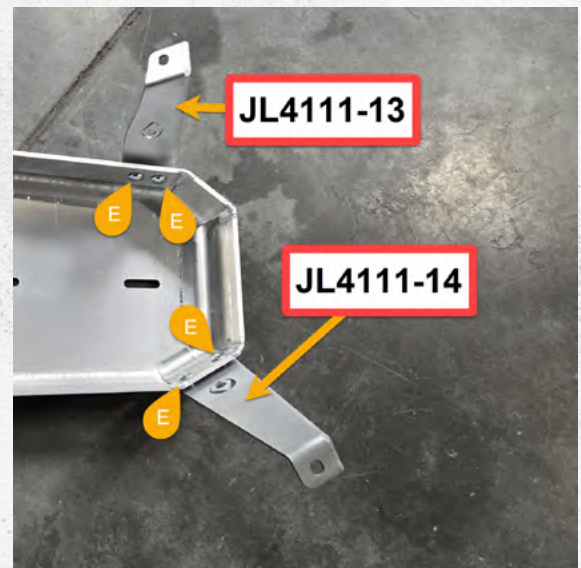

FUEL TANK SKID INSTALL

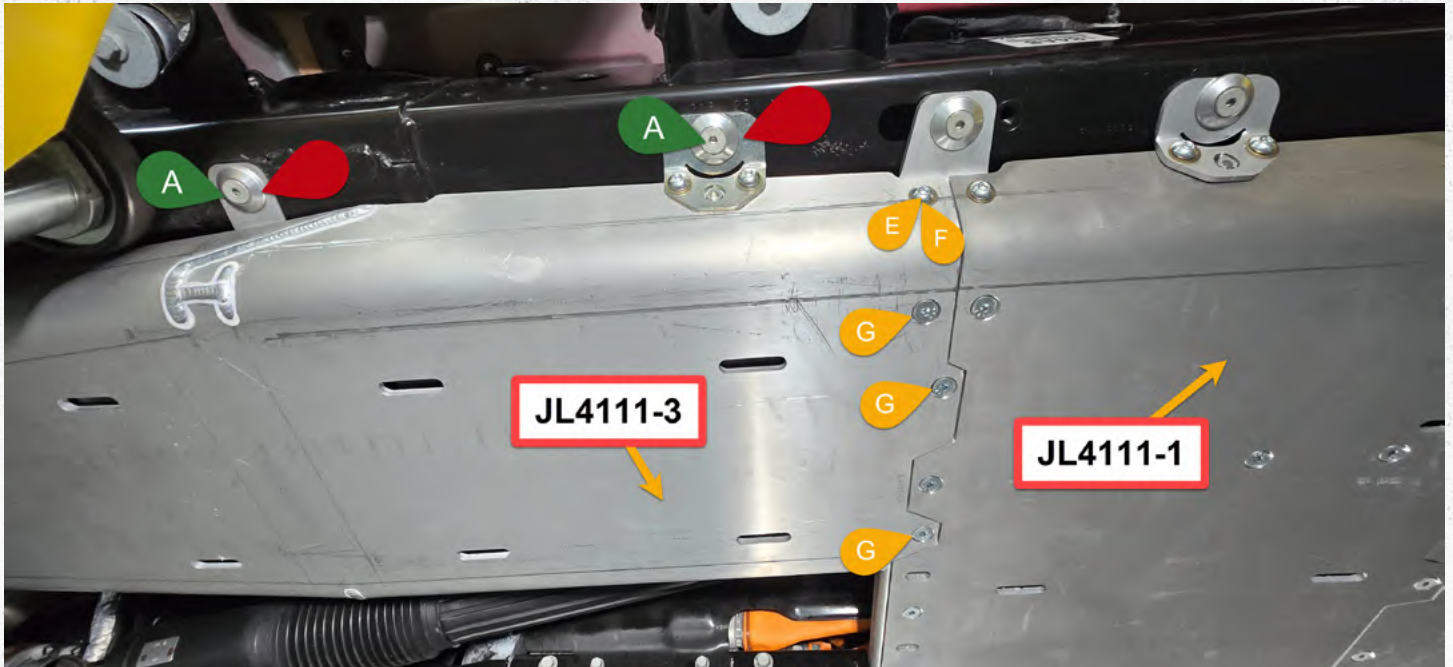

Step 39:

Install the hardware as follows.

RED Aluminum washer

GREEN A 40mm M12 countersunk bolt

Yellow B 3/8x 1 countersunk bolt

Yellow E 3/8 zinc washer

Yellow F 3/8 x 1 Button head screw

Yellow G 3/8 x .75 countersunk bolt

All hardware will remain loose until the end of installation.

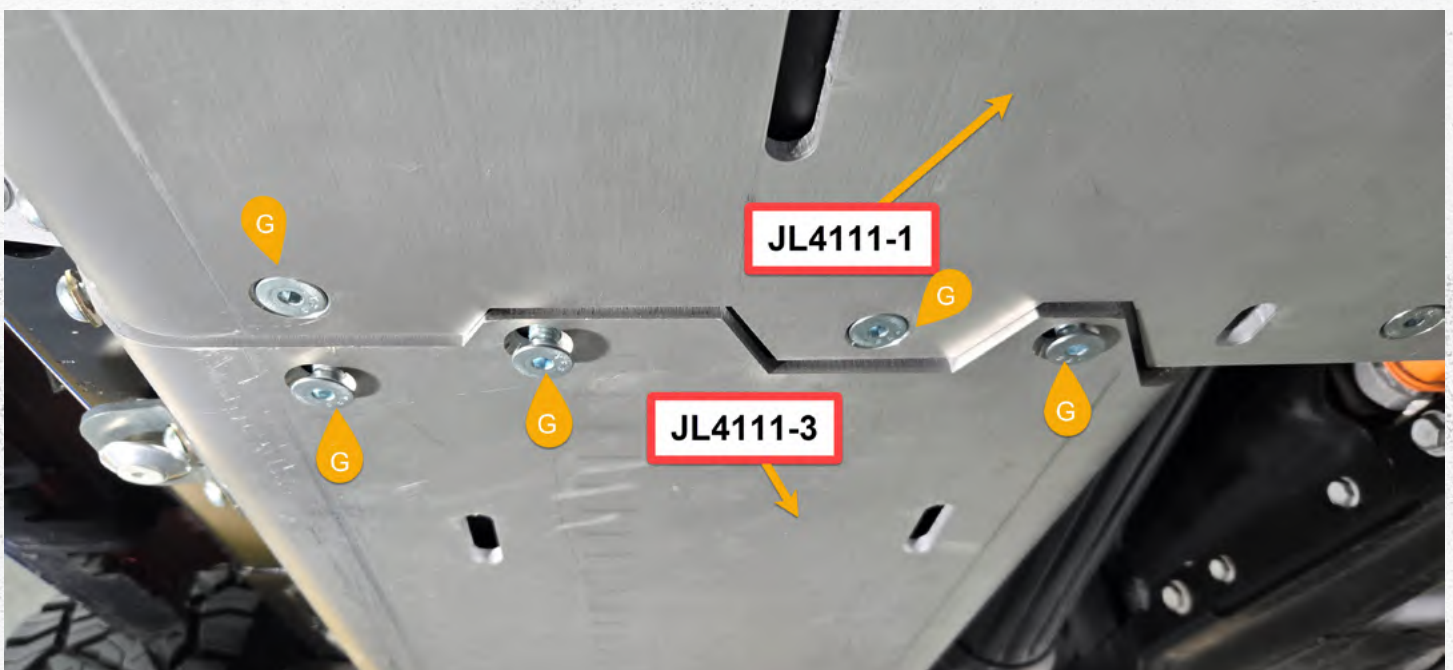

FUEL TANK SKID PRE-INSTALL

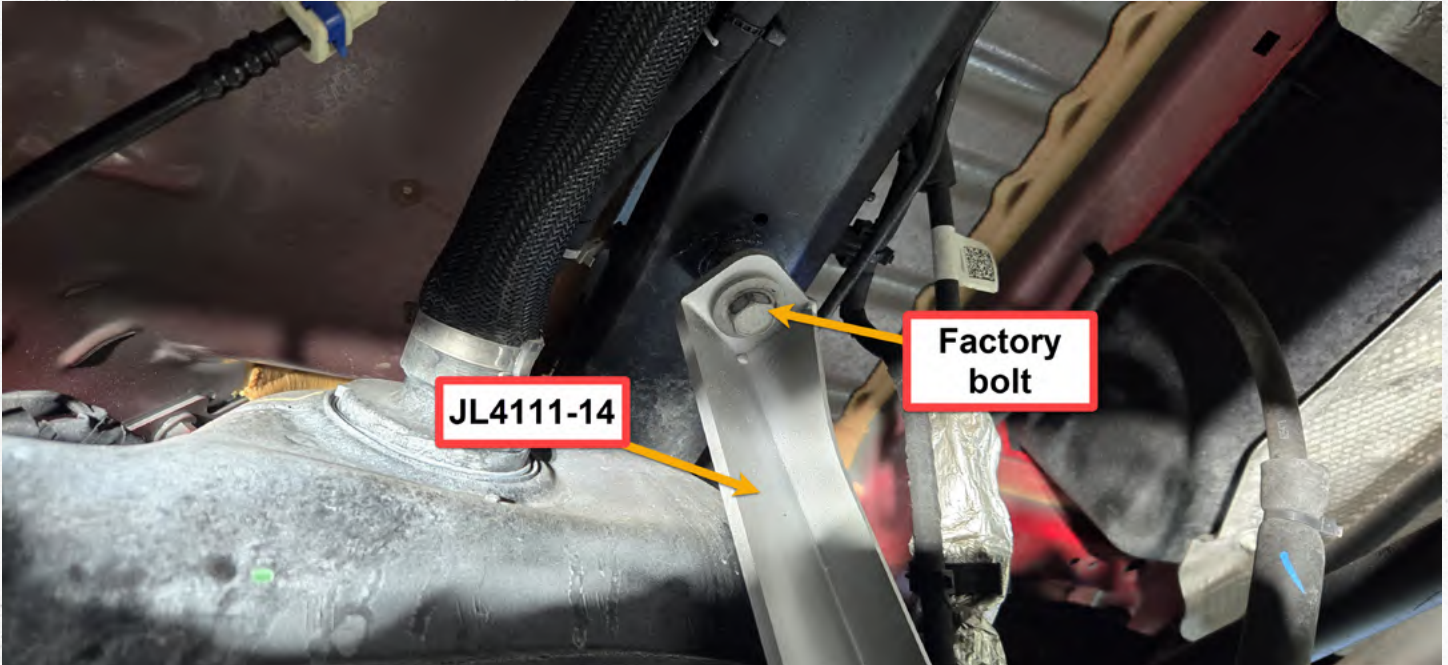

Step 40:
Install the factory 18mm bolt to secure **JL4111-14**

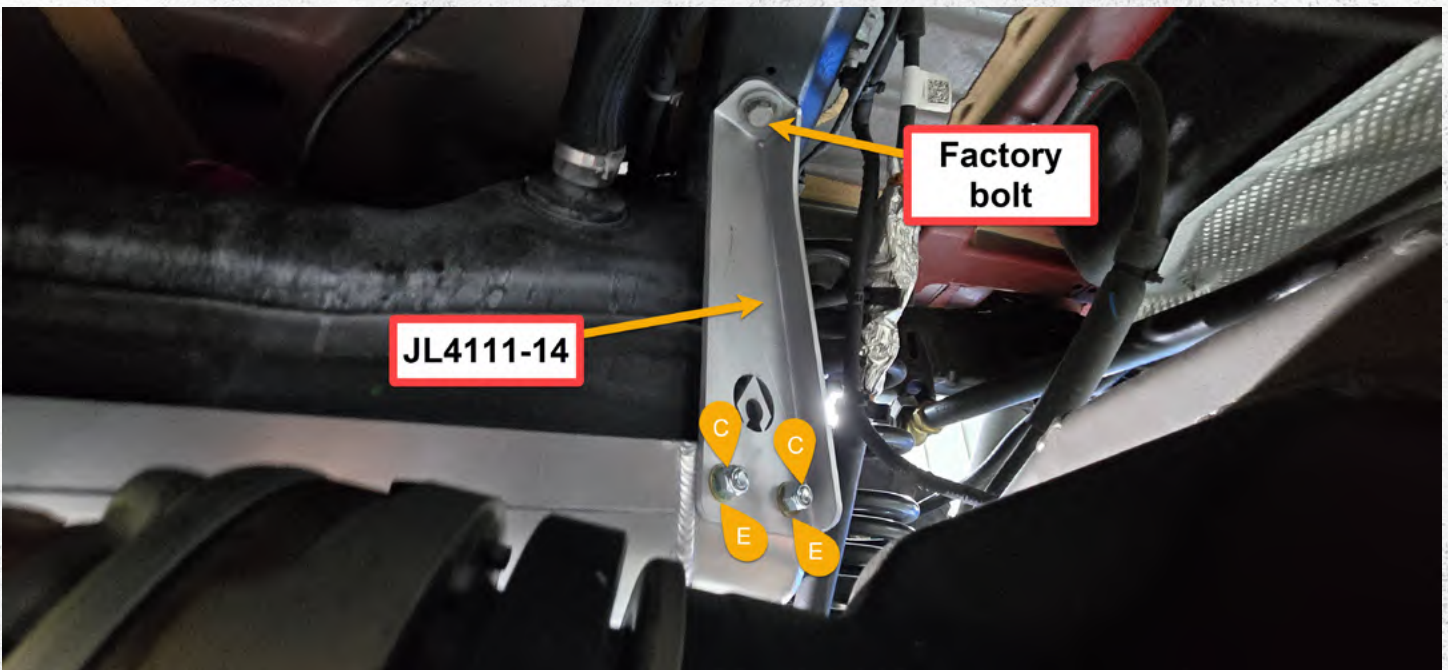

Additional view of step showing hardware location with 3/8 lock nuts installed.

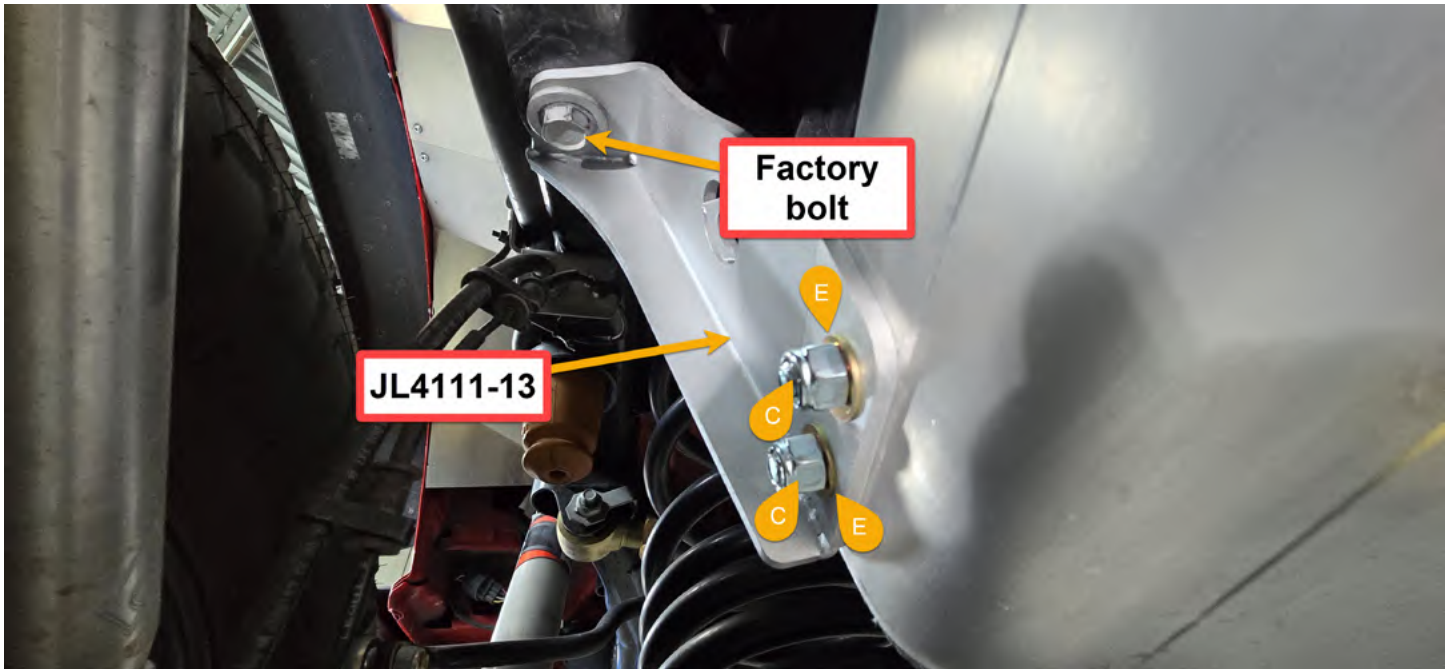

Step 41:

Secure **JL4111-13** using a factory 18mm bolt. Pictured is the 3/8" lock-nuts and washers used to secure **JL4111-13** to the skid-plate.



Step 42:

Tighten all hardware moving from the rear of the vehicle to the front.



Step 43:

Once the skid plate hardware is tight, drill a 3/8" hole in the location shown.

NOTE: Using a smaller bit to first drill a pilot hole will help

Insert **UB1001** 3/8" nut plate **GREEN 2** into the frame as shown and loosely install 1 - 3/8" x 1.5" flat head bolt **ORANGE 1** with a 7/32" hex bit.

Verify ALL previously installed hardware is tight / torqued to specifications.



CONCLUSION

Congratulations on finishing the installation for your Artec Industries 4xE engine Skid. Before driving your vehicle, inspect all bolts to ensure they are properly tightened.

If you used a vehicle lift, take proper care to ensure you lower your vehicle safely.

Now take your vehicle out and enjoy the outdoors in confidence.

MAINTENANCE / CARE

- After 500 miles, inspect all components and hardware to ensure they are properly fastened.
- If driving during the winter where salt is used on the roads, thoroughly and frequently wash underside of vehicle to prevent salt based corrosion.
- If removal of skid panels is required for vehicle maintenance, and bolts will not loosen, tap the bolt heads with a small sledge hammer using moderate force. This will allow the threads to loosen.
- Spray wax or similar products can be used to create a protective barrier on raw metals to protect against long term corrosion.