

advanced FLOW engineering Cold Air Intake System

Instruction Manual P/N: 50-70133D / 50-70133R

Make: Ford

Model: Edge

Year: 2019-2024

Engine: I4-2.0L (t)

Make: Lincoln

Model: Nautilus

Year: 2019-2023

Engine: I4-2.0L (t)



9

- Please read the entire instruction manual before proceeding.
- Ensure all components listed are present.
- For technical support please call 951-493-7185.
- Ensure you have all necessary tools before proceeding.
- Do not attempt to work on your vehicle when the engine is hot.
- Retain factory parts for future use.

Label	Qty.	Description	Part Number
A1	1	Air Filter (Pro 5R)	20-91210R
A2	1	Air Filter (Pro DRY S)	20-91210D
B	1	Intake Tube, Turbo Side	05-5070079B1
C	1	Intake Tube, Filter Side	05-5070133B1
D	1	Housing	05-5070094B2
E	4	Clamp, 048 (2-9/16" - 3-1/2 ")	03-50007
F	1	Inlet Trim: Scoop	05-01740
G	1	Coupling, Silicone Hump: 3"ID x 2-1/4"L	05-01245
H	2	Fitting, SAE 15.82 - 5/8" to 3/8" NPT	05-01339
J	1	Fitting, CCV Vacuum	05-01698
K	1	Grommet, Silicone; 05-01698 Fitting	03-50751
M	1	Coupling, Silicone Bellow Rdr: (3.25-3.12)"IDx3"L	05-01599
N	1	Fitting, Air Temp Sensor	05-01454
P	1	Grommet, Rubber	03-50167

Installation will require the following tools:

Panel clip remover, 7mm & 8mm nut driver, 8mm socket and driver, 20mm wrench or adjustable wrench and tongue pliers

Warranty Information available at <https://afepower.com/contact#warranty>

Emissions Disclaimer: This product is not currently CARB exempt and is not available for purchase in California or for use on any vehicle registered with the California Department of Motor Vehicles.

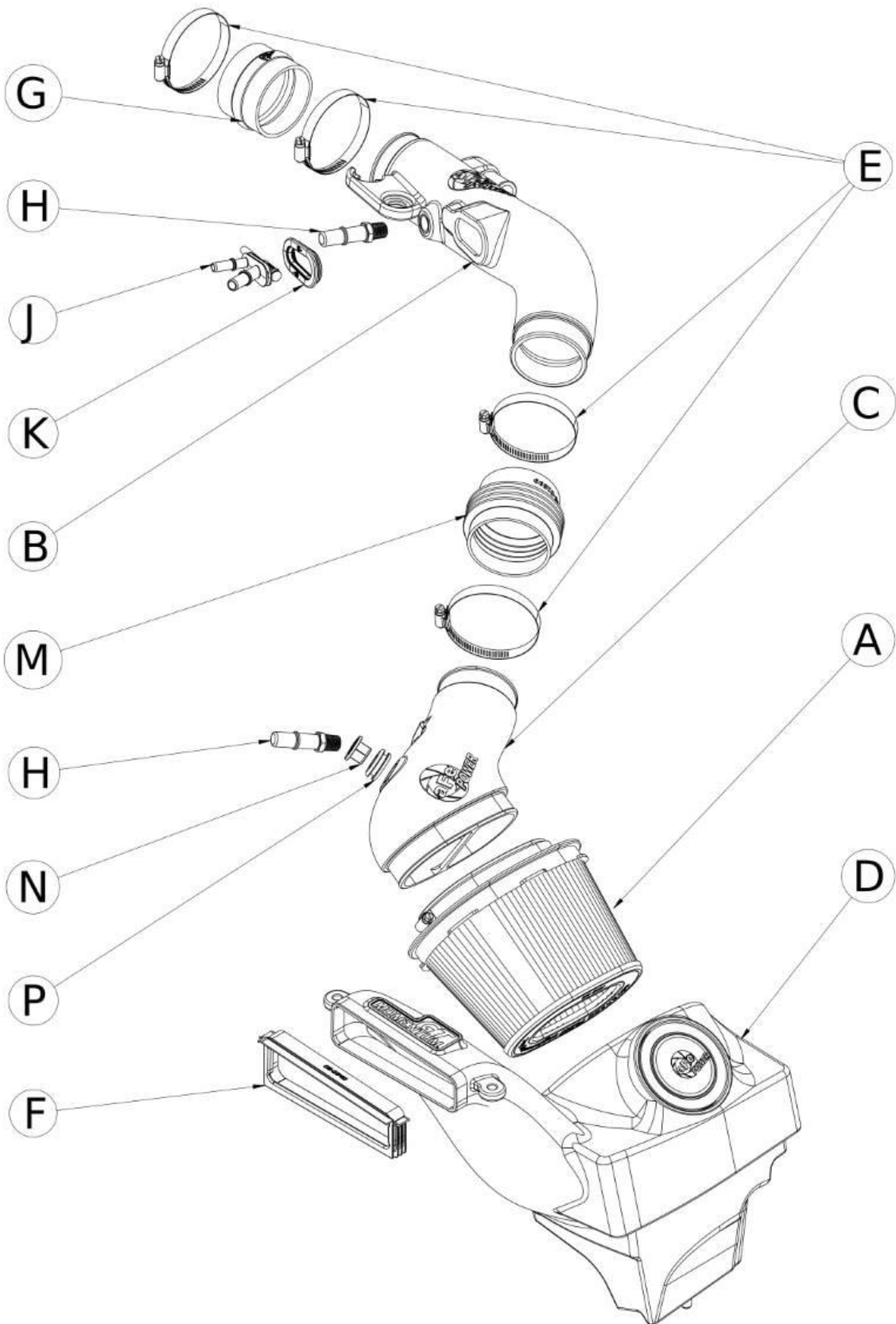

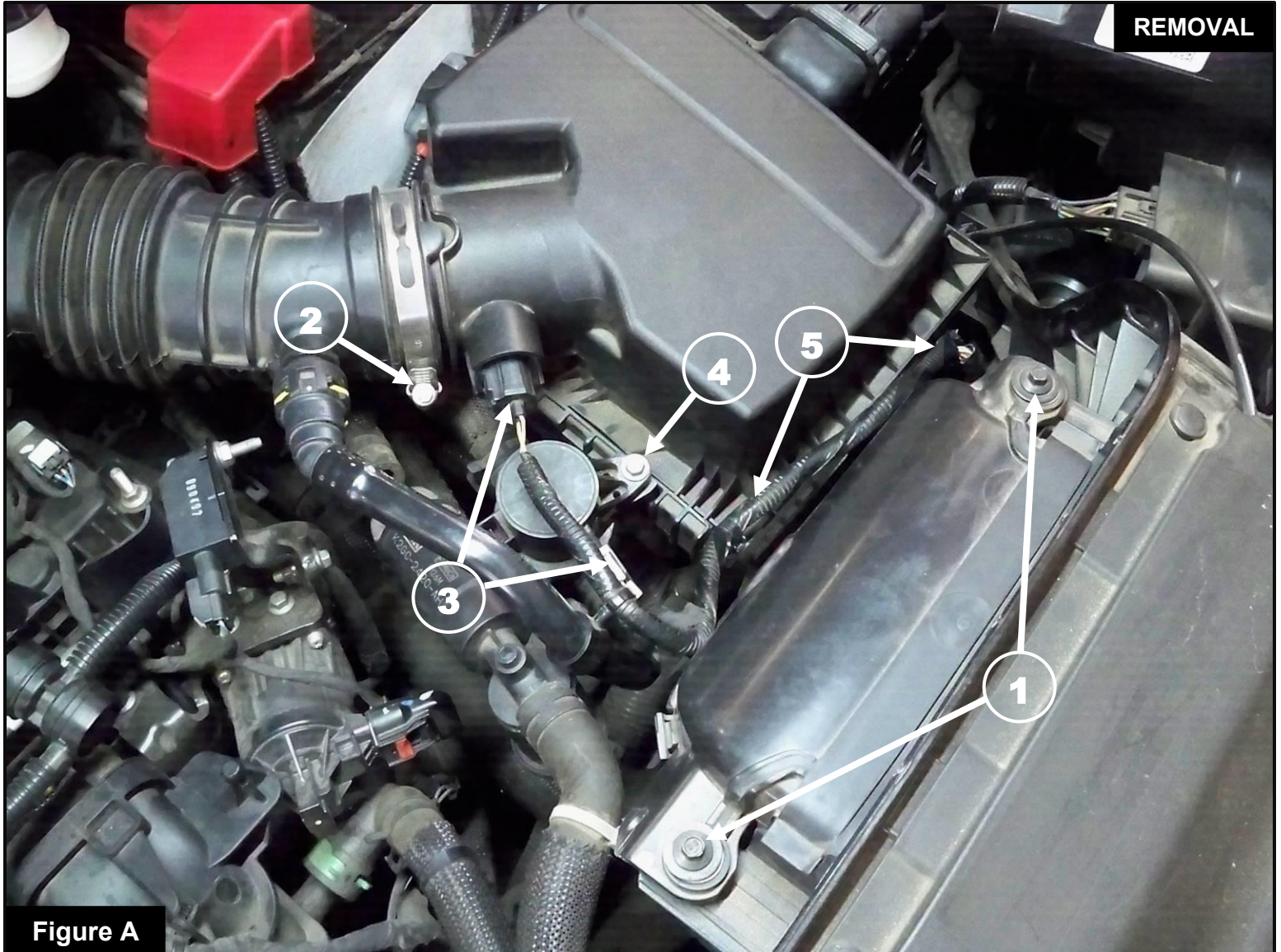

Figure A

Refer to Figure A for Steps 1-5

Step 1: Using a 7mm nut driver, remove the two screws ① retaining the inlet of the factory airbox and set them aside.

Step 2: Using a 7mm nut driver, loosen the clamp ② at the factory intake rubber tube. Detach the intake rubber tube from the factory airbox.

Step 3: Disconnect the IAT sensor and vacuum manifold electrical connectors ③.

Step 4: Using an 8mm nut driver, remove the screw ④ retaining the vacuum manifold and set aside.

Step 5: Detach the two retainer clips ⑤ from the factory airbox.



Figure B

Refer to Figure B for Step 6

Step 6: Detach and remove the factory airbox from the isolators ⑥. If the isolators are pulled out and are stuck in the lower half of the factory airbox, remove them and insert them back on the mounting brackets.

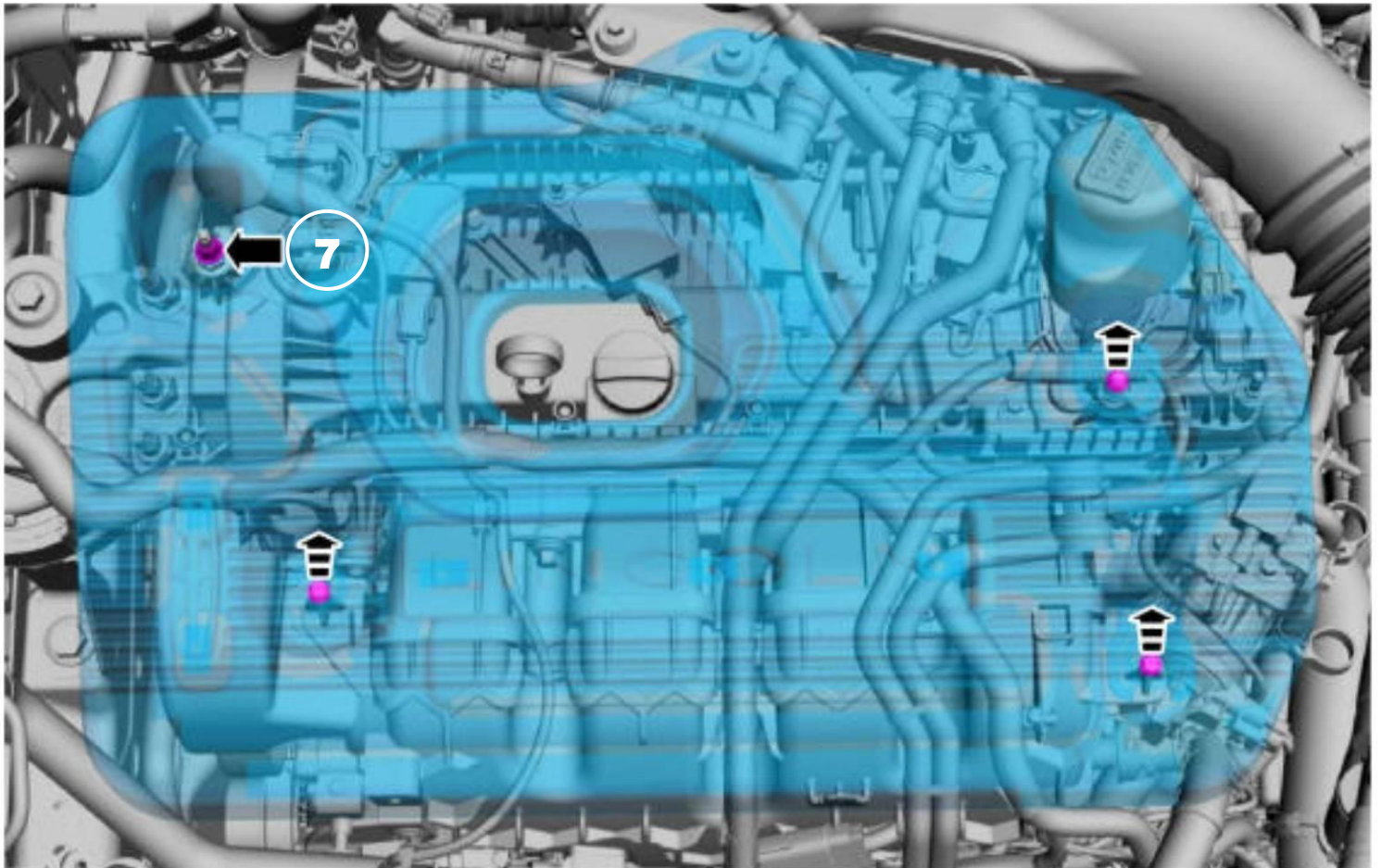
Figure C

Refer to Figure C for Steps 7-9

Step 7: If the vehicle has an engine cover, remove the engine cover nut (7).

Note: If not equipped with an engine cover then move to step 10.

Step 8: Place your hand under the engine cover at each grommet location and push straight up to release each grommet from the studs.

Step 9: After all the grommets have been released from the studs, remove the engine cover from the engine and set aside.

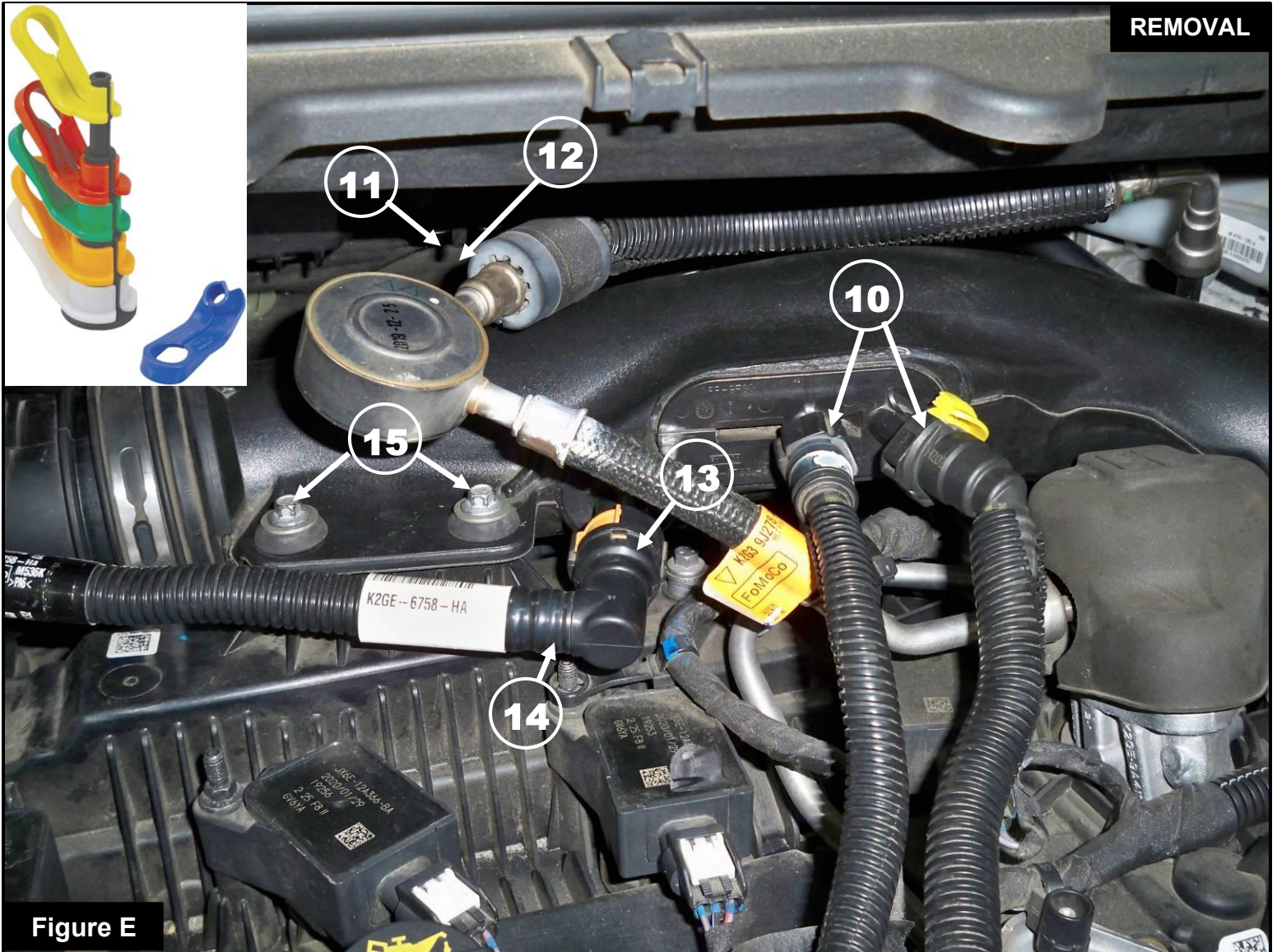

Figure D

Refer to Figure D for Steps 10-11

Step 10: Disconnect the quick release connector (8) and set the hose assembly aside.

Step 11: Using a 7mm nut driver, loosen the clamp (9) at the factory turbo intake tube.

Figure E

Refer to Figure E for Steps 12-16

- Step 12: Disconnect the quick release connectors (10) for the fuel vapor hoses and set aside.
- Step 13: Using tongue pliers, loosen the clamp (11) and disconnect the bypass valve hose (12).
- Step 14: Disconnect the crankcase vent tube quick release connector by using a green size angled disconnect tool set as shown. If necessary, cut the lock tab from the permanent connector (13) using side cutter pliers and rotate the crankcase vent tube (14) out of the way. Replace the crankcase vent tube if the tabs were cut.
- Step 15: Using an 8mm socket and driver, remove the screws (15) holding the intake tube and set aside for reuse.
- Step 16: Remove the factory intake tube.

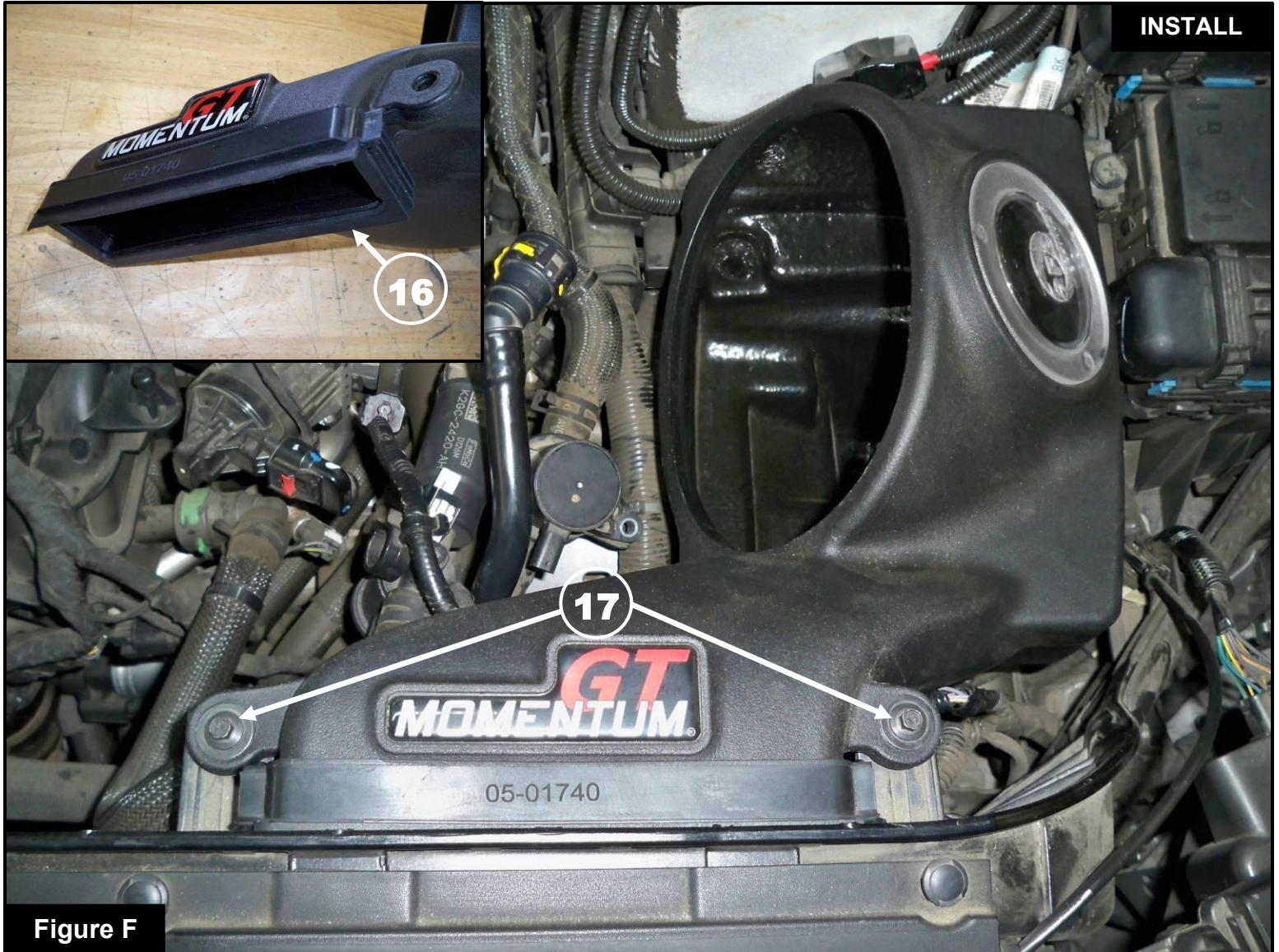

Refer to Figure F for Steps 17-19

Step 17: Install the inlet trim seal (16) onto the aFe POWER housing.

Step 18: Install the aFe POWER housing into the vehicle. Make sure housing pins are aligned and all the way through the isolators. Route the IAT sensor and vacuum manifold electrical wire harness under the scoop section of the housing.

Step 19: Using a 7mm nut driver, reinstall the two screws (17) removed on step 1.

**Figure G****Refer to Figure G for Step 20**

Step 20: Slide the aFe POWER filter and clamp into the aFe POWER housing and push them in until it locks into place. Do not tighten the clamp at this time.

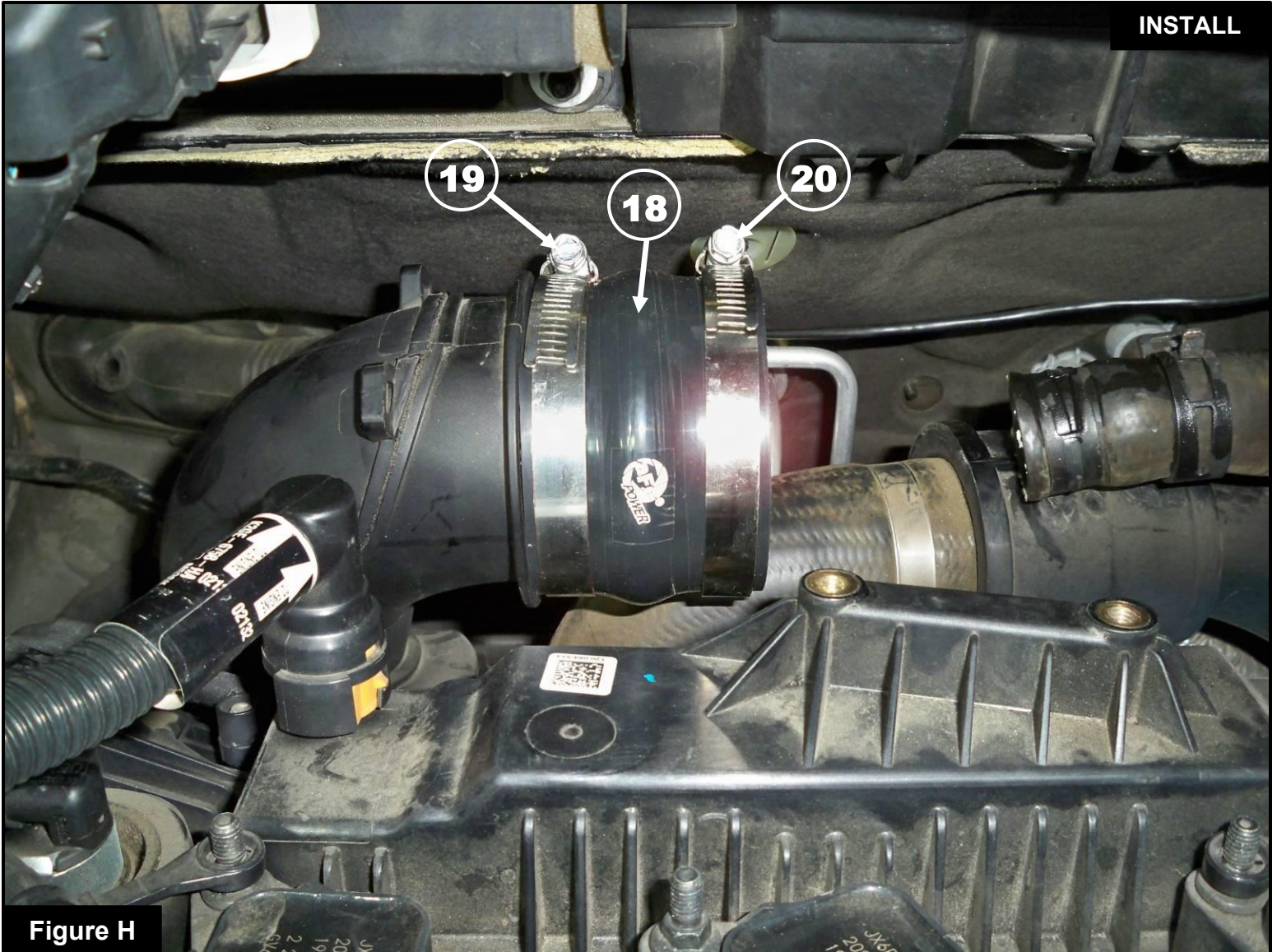
**Figure H****Refer to Figure H for Steps 21-22**

Step 21: Install the supplied hump coupler (18) onto the factory turbo intake tube with one of the supplied #48 clamps (19) and tighten the clamp using an 8mm nut driver.

Step 22: Place another #48 clamp (20) onto the hump coupler and slightly snug so it will not fall off.

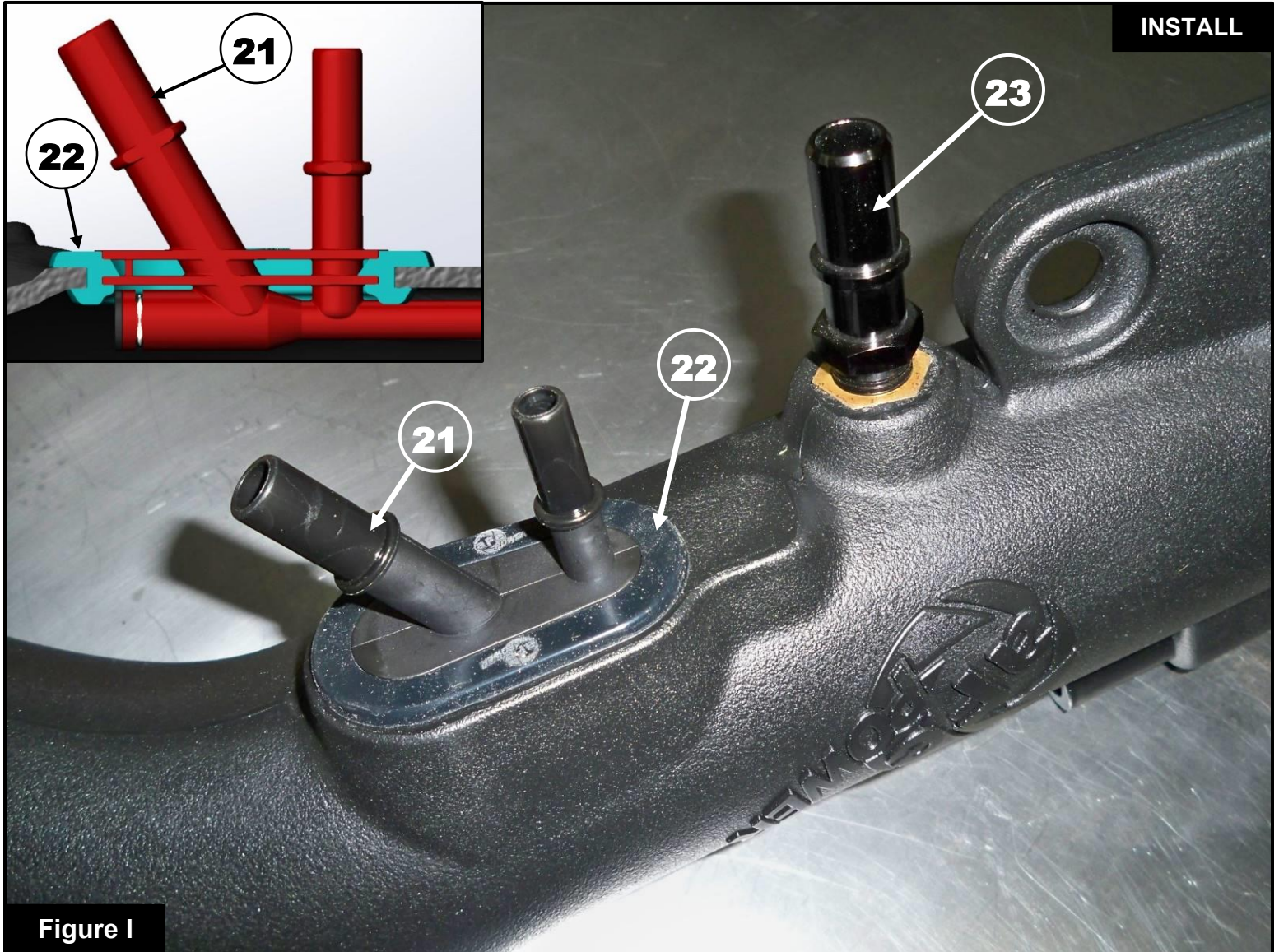

Figure I

Refer to Figure I for Steps 23-25

Step 23: Install the supplied plastic fitting (21) into the fitting grommet (22). Make sure the inside thicker bead of the grommet is fully seated in between the two flat surfaces of the fitting (as shown in the drawing). The logo side of the grommet should seat flat to the fitting as shown.

Step 24: Install fitting and grommet assembly on the turbo side aFe POWER intake tube. Make sure the grommet is fully seated to the intake tube so there are no leaks around the grommet area.

Step 25: Using a 20mm wrench or adjustable wrench, install the supplied aluminum vent fitting (23) into the turbo side aFe POWER intake tube. Do not overtighten, some threads will still be exposed.



Figure J

Refer to Figure J for Steps 26-27

Step 26: Remove the metal sleeves and isolators (24) from the factory intake tube.

Step 27: Install the metal sleeves and isolators into the turbo side aFe POWER intake tube as shown.

Figure K

Refer to Figure K for Steps 28-31

Step 28: Install the turbo side aFe POWER intake tube by sliding it into the hump coupler (25).

Step 29: Align the tube correctly and reinstall the two screws (26) removed earlier. Using an 8mm socket and driver, tighten down the two screws.

Step 30: Connect the bypass valve hose (27) and install the clamp.

Step 31: Tighten the clamp (28) at the coupler using an 8mm nut driver.

Figure L

Refer to Figure L for Steps 32-33

Step 32: Install the crankcase vent tube connector (29). If the crankcase vent tube was previously cut, install a new crankcase vent tube.

Step 33: Fold back the fuel line (30) over the turbo side aFe POWER intake tube as shown, and reconnect the quick release connectors (31) for the fuel vapor hoses.



Figure M

Refer to Figure M for Steps 34-36

Step 34: Place a #48 clamp (32) onto the smaller opening side of the bellows coupler.

Step 35: Install the smaller side of the bellows coupler (33) onto the end of the turbo side aFe POWER intake tube as shown and tighten the clamp using an 8mm nut driver.

Step 36: Place a #48 clamp (34) onto the bellows coupler end. Snug the clamp, but do not fully tighten it.

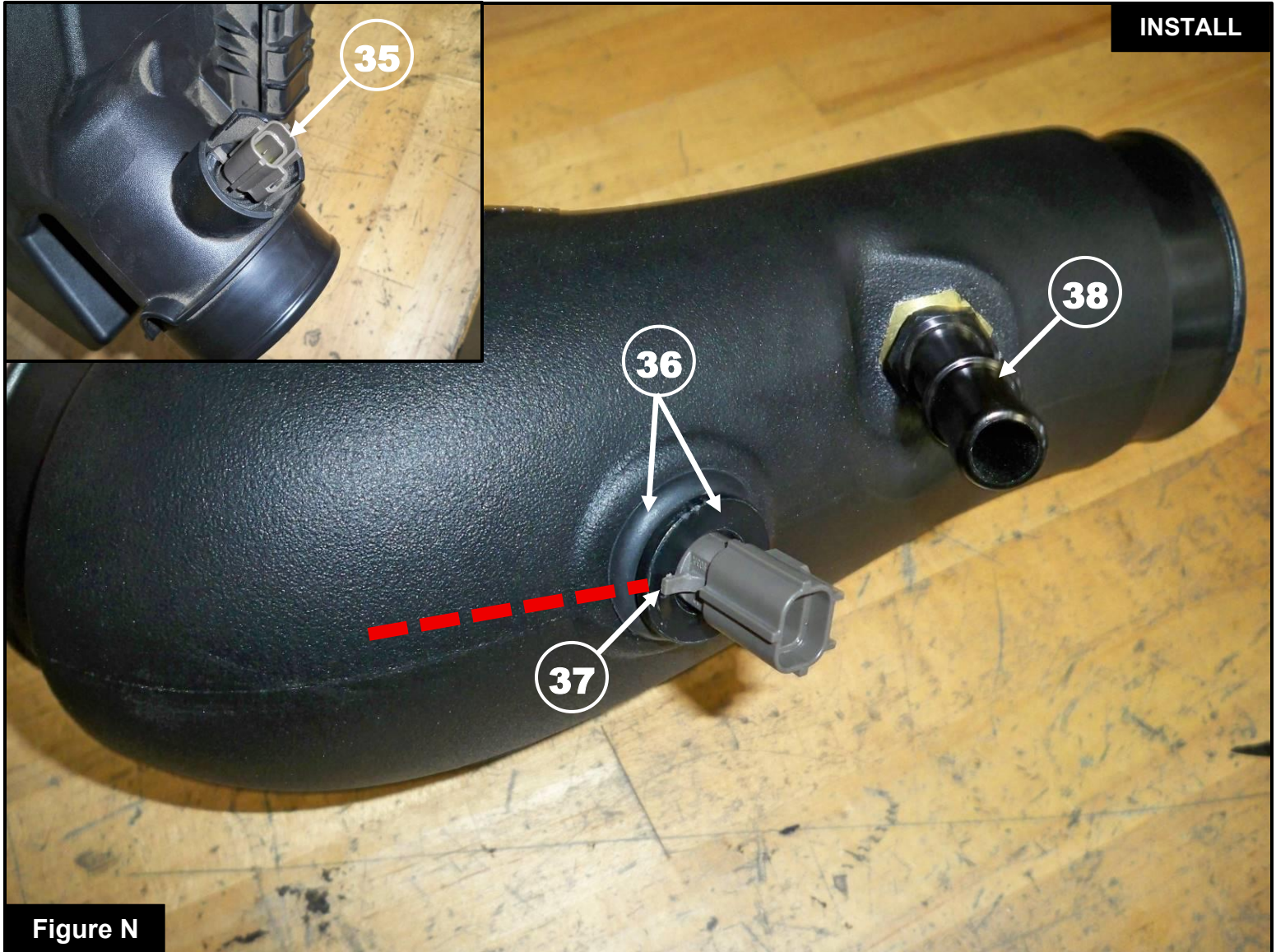

Figure N

Refer to Figure N for Steps 37-40

Step 37: Remove the IAT sensor (35) from the factory airbox by rotating ¼ turn counterclockwise and gently pulling out.

Step 38: Install the provided grommet and temp sensor fitting (36) into the the filter side of the aFe POWER intake tube.

Note: Lubricant can be used to facilitate the installion of the fitting into the grommet.

Step 39: Install the IAT sensor into the temp sensor fitting by rotating ¼ turn clockwise until it locks into place. Rotate the temp sensor fitting to have mounting tab (37) pointing in the direction of the tube opening.

Step 40: Using a 20mm wrench or adjustable wrench, install the supplied aluminum vent fitting (38) into the aFe POWER intake tube. Do not overtighten, some threads will still be exposed.

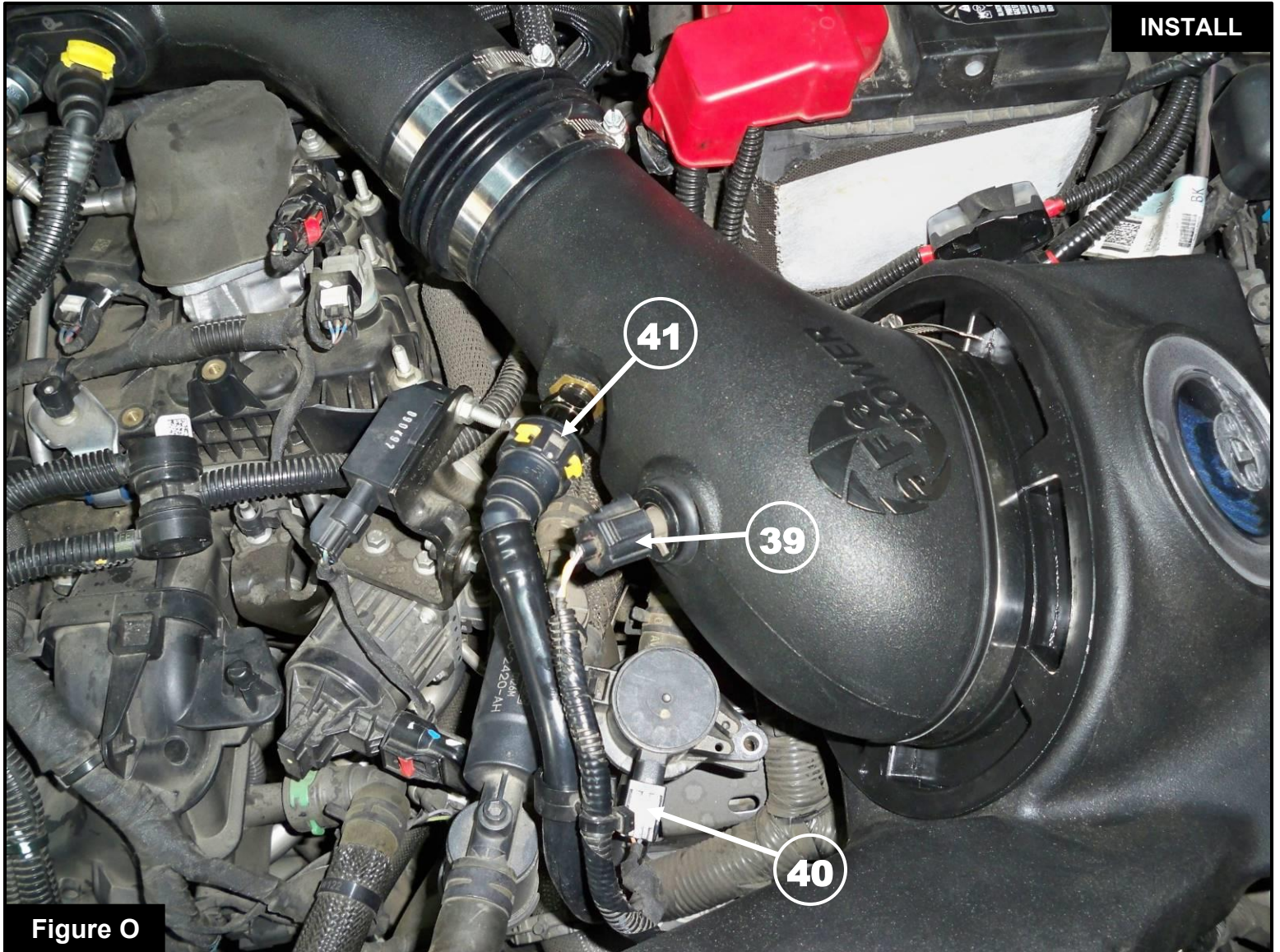
**Figure O****Refer to Figure O for Steps 41-44**

Step 41: Install the filter side aFe POWER intake tube into the coupler first and then into the air filter. Align the tube correctly and tighten the coupler and filter clamps using an 8mm nut driver.

Step 42: Connect the IAT sensor electrical connector (39).

Step 43: Connect the vacuum manifold electrical connector (40).

Step 44: Reconnect the quick release connector (41).

**Figure P****Refer to Figure P for Step 45-46**

Step 45: Reinstall the engine cover if the vehicle came with one.

Step 46: Check all the components are tight and secure. Your installation is now complete. Thank you for choosing aFe POWER!

NOTE: Check all bolts, clamps, and connectors after 100-200 miles.

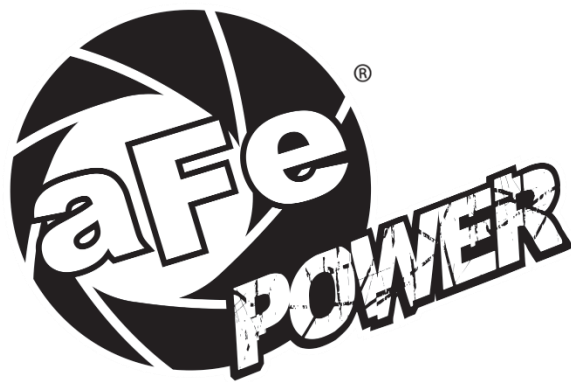

advanced FLOW engineering, inc.

Corona, CA 92879

<https://afepower.com/contact>