

advanced FLOW engineering Rapid Induction Air Intake System

Instruction Manual P/N: 52-10010R / 52-10010D

Make: FORD

Model: F-150

Year: 2021-2021

Engine: V6-3.5L(tt)

(Does not fit F-150 Equipped with the V6-3.5L(tt) PowerBoost™)



- Please read the entire instruction manual before proceeding.
- Ensure all components listed are present.
- If you are missing any of the components, call customer support at 951-493-7185.
- Ensure you have all necessary tools before proceeding.
- Do not attempt to work on your vehicle when the engine is hot.
- Retain factory parts for future use.

Label	Qty.	Description	Part Number
A1	1	Air Filter (Pro 5R) For 52-10010R	24-91040
A2	1	Air Filter (Pro DRY S) For 52-10010D	21-91040
B	1	Tube, Plastic	05-5210010B1
C	1	Housing, Sheet Metal	05-32642B2
D	1	Coupling, Silicone Reducer: (3-1/2" x 3")ID x 2-1/2"L	05-01580
E	1	Coupling, Silicone Bellow: 4"ID x 2-1/2"L	05-01399
F	1	Clamp, 044 (2-5/16" - 3-1/4")	03-50019
G	1	Clamp, 052 (2-13/16" - 3-3/4 ")	03-50008
H	2	Clamp, 064 (2-1/2"- 4-1/2 ")	03-50006
I	2	Screw, Hex head: M6 x 25mm	03-50114
J	2	Washer, Spring Lock: M6	03-50750
K	1	Seal, Trim: 7/16" bulb (23" Length)	05-00072
L	1	Grommet, Rubber	03-50167
M	1	Fitting, Air Temperature Sensor	05-01454
N	2	Cable Ties, Nylon	05-60167
O	1	Insert, Vent Tube	05-01405

Installation will require the following tools:

7mm, 8mm, and 10mm Nut Drivers or Ratchet and Sockets, Flat Head Screwdriver

Warranty Information available at: <https://afepower.com/contact#warranty>

Emissions Disclaimer: This product is not currently CARB exempt and is not available for purchase in California or for use on any vehicle registered with the California Department of Motor Vehicles.

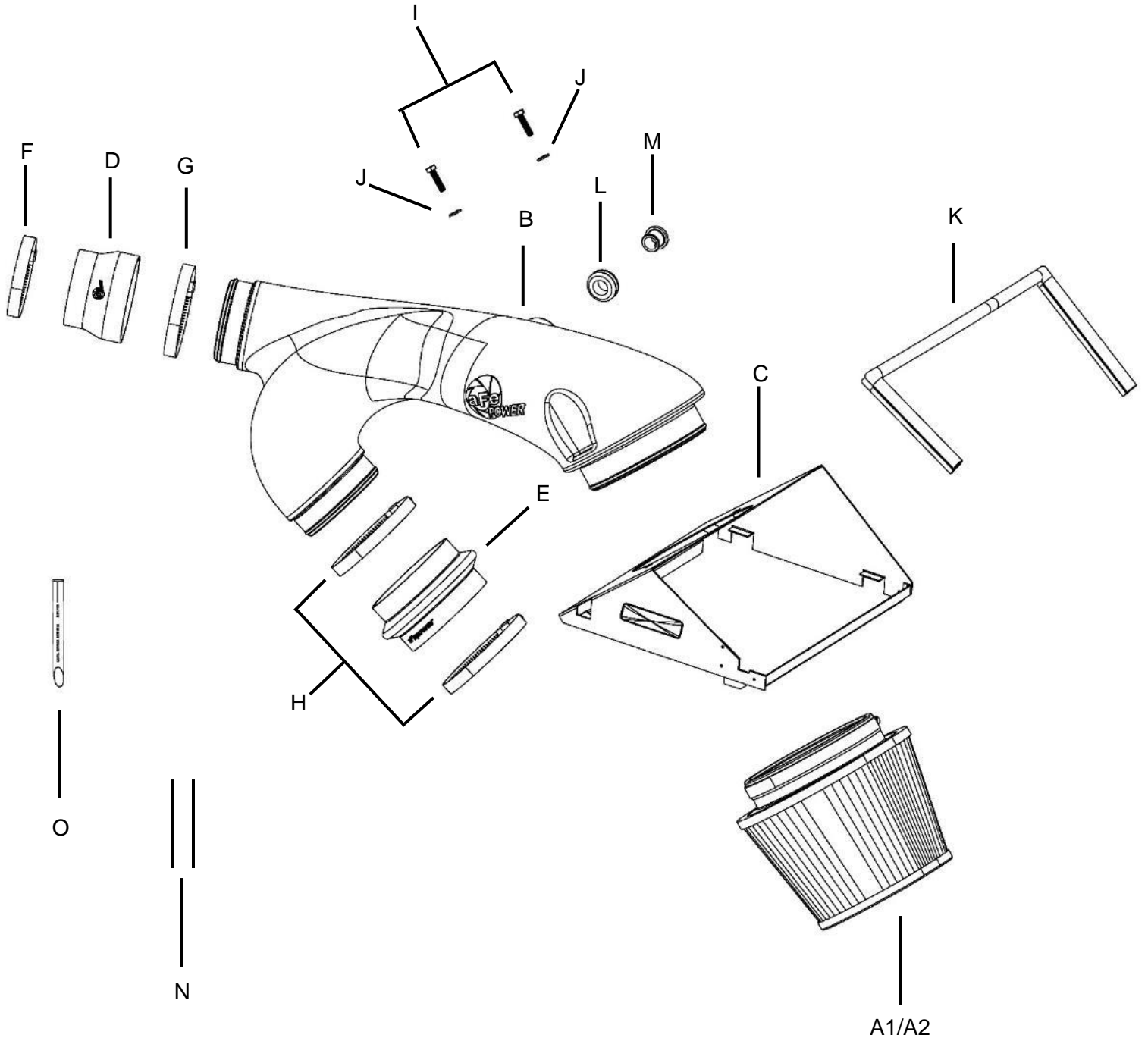

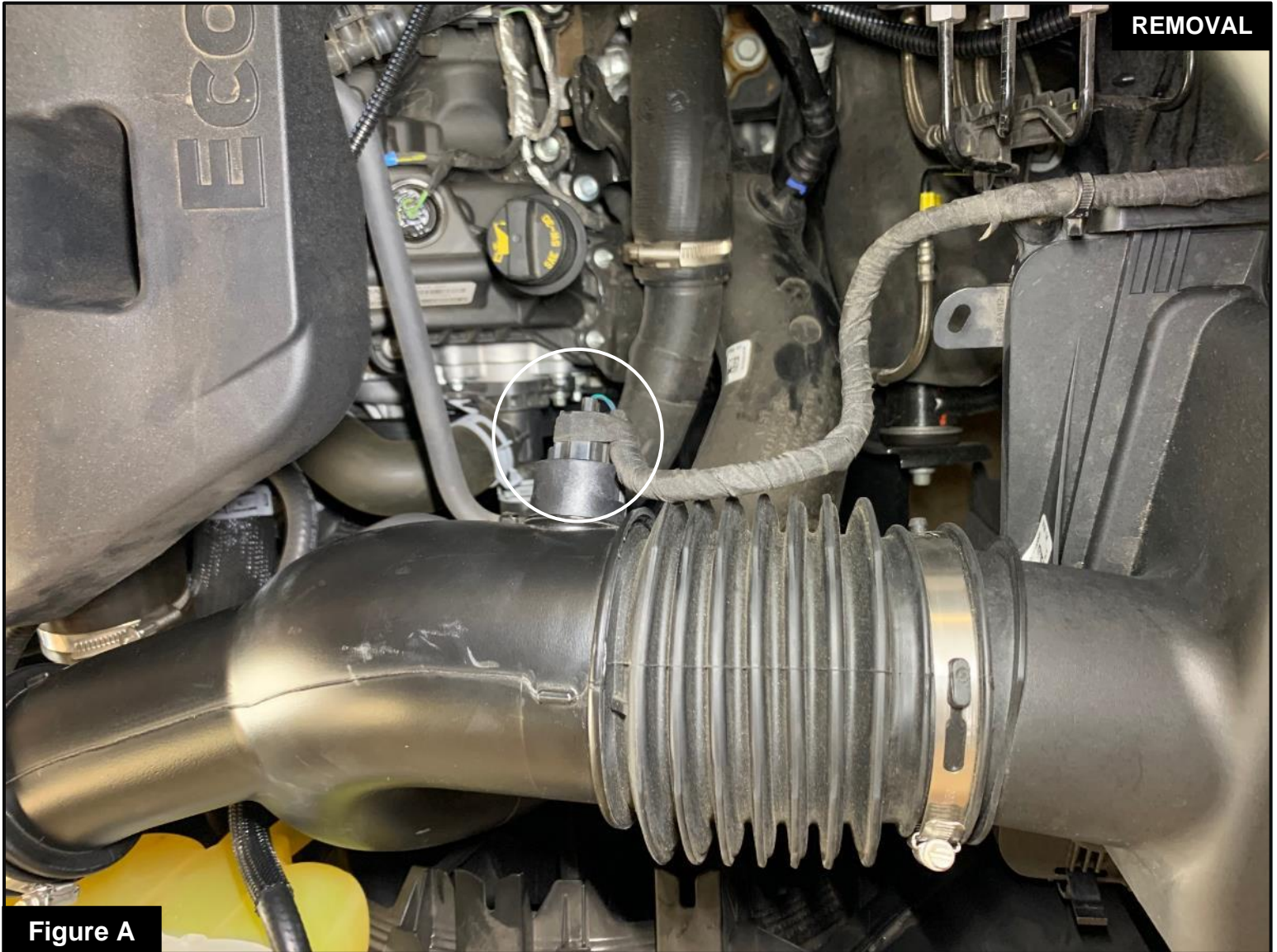

Figure A

Refer to Figure A for Step 1

Step 1: Unplug the temperature sensor harness.



Figure B

Refer to Figure B for Steps 2-4

Step 2: Loosen the two clamps connecting the intake tube to the turbo inlet tubes.

Step 3: Unclip the coolant line from the intake tube.

Step 4: Unclip the top of the factory air box and remove the intake tube, air filter and top of the air box from the vehicle.



Figure C

Refer to Figure C for Step 5

Step 5: Unclip the wire harness from the back of the air box.

If you have also purchased Rapid Induction Dynamic Air Scoop (D.A.S), Part number 52-10010S, 52-10010SR or 52-10010SL, you can proceed with the installation of that part at this step. Once the D.A.S. is installed, continue to Step 6.

**Figure D****Refer to Figure D for Step 6**

(The installation of the plastic vent tube insert is important to prevent a check engine light. These procedures should be done with the turbo inlet tubes installed on the engine. It is shown off the vehicle for better illustration.)

Step 6: Locate the factory plastic tube feeding the driver's side turbo inlet. This is the connection closer to the turbo.



Figure E

Refer to Figure E for Step 7

Step 7: Locate the valve cover vent tube that feeds into the driver's side turbo inlet. It is not necessary to remove the engine cover.

**Figure F****Refer to Figure F for Step 8**

Step 8: Note the release clip on the vent tube connectors. Apply pressure against the exposed tail and pull vent fitting off the turbo inlet tube. It is not necessary to disconnect at the valve cover end. There is a sensor and wire harness on this vent tube. Do not damage or remove these components.

INSTALL



Figure G

Refer to Figure G for Step 9

Step 9: Insert vent fitting with slash cut facing turbo. It should not be a loose fit. It is direction dependent and must not rotate once installed.

**Figure H****Refer to Figure H for Steps 10-11**

Step 10: Reconnect the vent fitting. It will snap over without having to release the plastic clip. Pull up slightly to confirm installation.

Step 11: Installation of the vent tube is complete. Any codes can be cleared with a code reader or by disconnecting the battery. You will lose any radio presets with battery disconnection.

(If removal of the vent insert is required, it can be pulled out with internal snap rings pliers.)

**Figure I****Refer to Figure I for Steps 12-13**

Step 12: Install the grommet into the hole on the aFe POWER tube. Press in the plastic fitting and orient it as shown in the picture to make sure the temperature sensor is clocked correctly.

Step 13: Remove the temperature sensor from the factory intake tube. Transfer it to the fitting onto the aFe POWER intake tube. Turn it clockwise until the tab locks it into place.

**Figure J****Refer to Figure J for Steps 14-16**

Step 14: Install seal trim on the top edge of the aFe POWER housing.

Step 15: Install the aFe POWER tube onto the housing using the provided spring washers and M6 screws.

Make sure the washers are installed in the orientation shown in the picture.

Step 16: Install the air filter onto the tube, and tighten the clamp.



Figure K

Refer to Figure K for Step 17

Step 17: Install the couplings and clamps onto the turbo inlets, do not tighten clamps yet.



Figure L

Refer to Figure L for Steps 18-19

Step 18: Install the complete assembly into the truck, start with the aFe POWER housing first, and then work the tube into the couplings.

Step 19: Tighten the clamps and secure the aFe POWER housing with the two clips on the airbox.



Figure M

Refer to Figure M for Step 20

Step 20: Connect the Intake Air Temperature sensor to the sensor harness. Secure harness with provided cable ties.



Figure N

Refer to Figure N for Step 21

Step 21: Verify all clamps and connections are secured. Your installation is now complete. Thank you for choosing aFe POWER!



Page left blank intentionally



Page left blank intentionally



advanced FLOW engineering, Inc.

252 Granite Street Corona, CA 92879

<https://afepower.com/contact>