



INSTALLATION INSTRUCTIONS

Rock Basher Cat-Back Exhaust

MAKE: Ford
MODEL: Ranger
YEAR: 2024-25
ENGINE: L4-2.3L(t)

49-43150

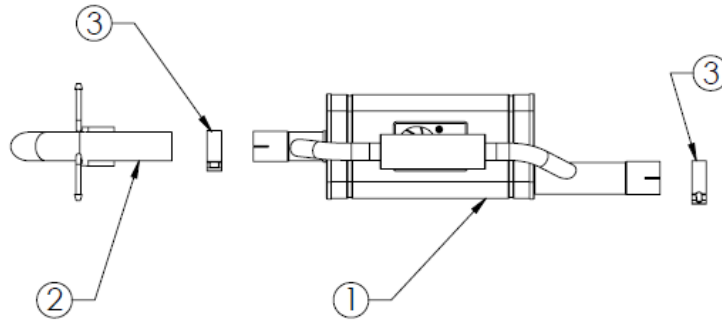

Item	Description	Part Number	Quantity
1	S/A Muffler Assembly	05-244550	1
2	S/A Tail Pipe, Hi-Tuck	05-244571	1
3	2-1/2" Band Clamp	05-41061	2

aFe POWER recommends professional installation on this product. Thoroughly inspect the aFe POWER exhaust system to make sure there is no damage from shipping (if damage is noted, immediately contact aFe POWER customer service). Allow time for your vehicle to cool down prior to installation. When working on your vehicle proceed with caution. Wear protective safety equipment; eye goggles and gloves to ensure a safe installation.

Install band clamps to proper torque specifications of 40-45 ft-lb.



1



INSTALLATION INSTRUCTIONS

Rock Basher Cat-Back Exhaust

49-43150

MAKE: Ford
MODEL: Ranger
YEAR: 2024-25
ENGINE: L4-2.3L(t)

1. **(Read instructions prior to installation.)** It is recommended not to fully tighten the exhaust until it has been fully installed. Leave loose for adjustability.
2. Secure vehicle on jack stands (refer to your manual for specified jack stand positions).
3. For faster installation, spread out the parts of the exhaust alongside your vehicle as shown in the diagram above.
4. Secure the stock exhaust with jack/stands.
5. Remove the OE exhaust system. Retain Hardware, it will be re-used.
6. Install the Muffler Assembly with the supplied 2 1/2" clamp, Support the front pipe to prevent excess stress on the downpipe flex joint.
7. Hang the muffler assembly on the factory isolators.
8. Install the tailpipe onto the muffler assembly with the supplied 2-1/2" clamp.
9. Hang the tailpipe assembly on the factory isolators.
10. Ensure that all the components of the aFe POWER exhaust system are aligned and are at a safe clearance from all wires, hoses, brake lines, body parts, and tires.
11. Start from the front of the aFe exhaust system and evenly tighten all clamps and fasteners.
12. Start the vehicle and check for any leaks. If any leaks are found, determine cause and repair as necessary.
13. Remove vehicles from jacks stands.
14. It is recommended to re-tighten all clamps and hardware after 50-100 miles.