

INSTALLATION SHEET

Any damaged or missing parts?

Parts will be shipped to you directly.

Call 866-658-8376, Mon - Fri, 8:00 a.m. - 4:00 p.m. EST

NOTE: It is important that all areas where the bed cover mounts are clean and free of debris prior to installing.

TOOLS REQUIRED

- 7/16" wrench or socket
- 1/2" wrench or socket
- Utility knife
- Isopropyl alcohol

PARTS INCLUDED IN YOUR KIT

- A** Truck bed cover
- B** 2x Front mounting brackets
- C** 2x Rear mounting brackets
- D** 2x Hydraulic struts
- E** 8x Clamps
- F** 8x Bolts
- G** 8x Washers
- H** 8x Lock washers
- I** 2x J-hooks
- J** 4x Wall mounting screws
- K** 4x Bar hinge with twist knobs (pre-installed on the cover)
- L** 8x Spacers
- M** 2x Seals
- N** 1x Bulkhead seal
- O** 2x Hex bolts

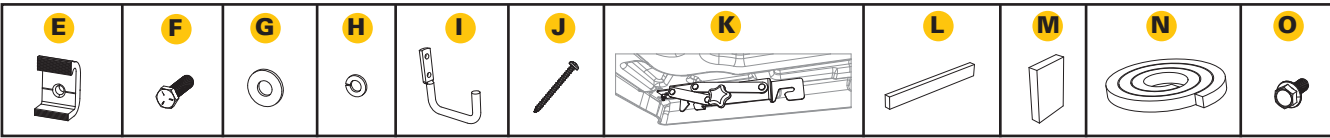
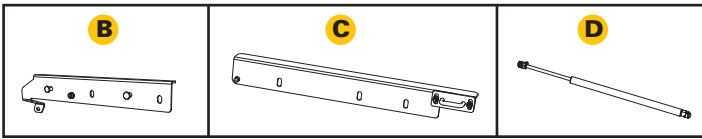
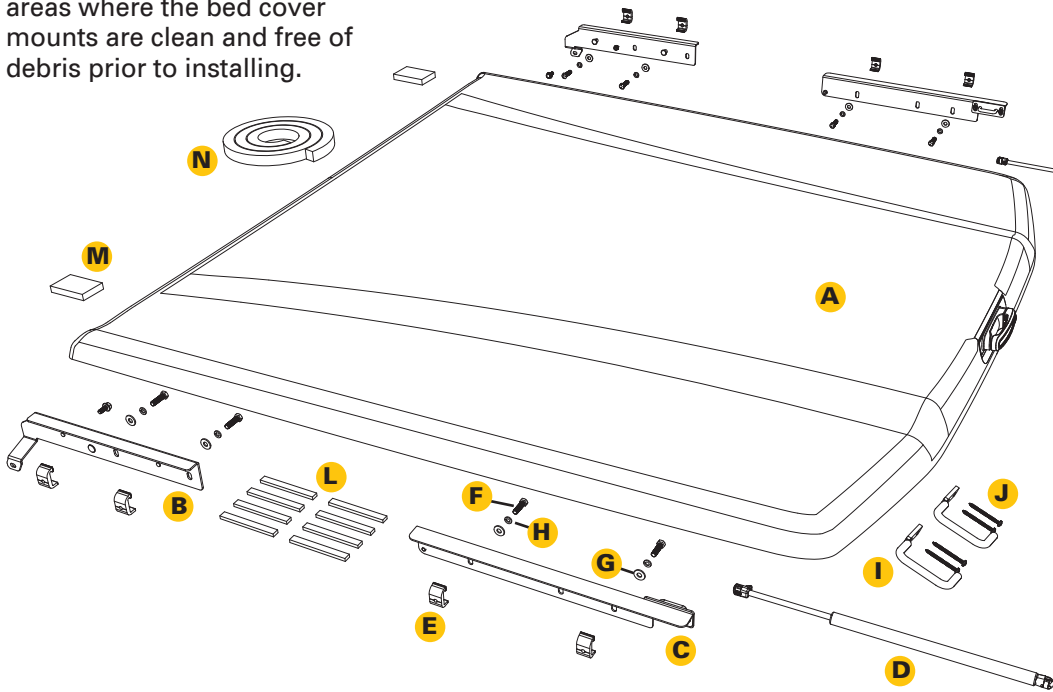

1 If NO plastic drop-in bedliner is present, skip to step 2. Trucks that have plastic drop-in bedliners will require some minor trimming of the bedliner to ensure proper placement of the mounting brackets (B & C).

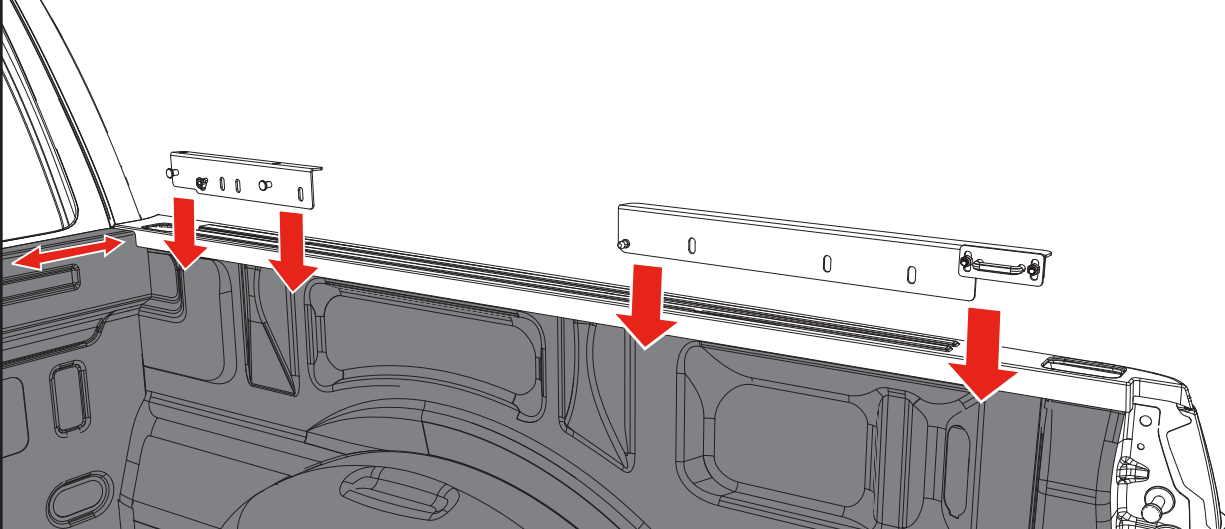

2 If a plastic drop-in bedliner is present, skip to step 3. The square seals (M) are installed on trucks without a drop-in bedliner. Clean the area where the seal will go with soap and water to remove dirt and debris. Then clean the area with isopropyl alcohol to remove wax or grease and to evaporate any remaining water, allow the surface to dry. Next, remove the backing paper and position one seal up into the corner, under the bed rail cap, and onto the bulkhead face. Apply pressure to the entire seal to make sure the adhesion is good. Place one seal on both the driver and passenger sides.

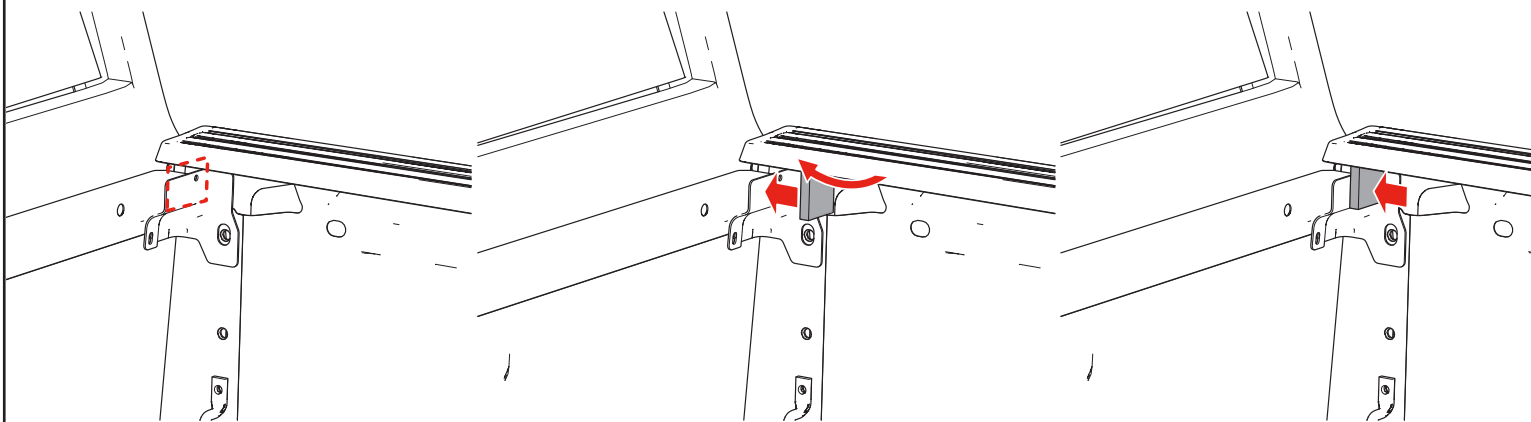

3 Clean and prepare the bulkhead surface as directed in step 2. Peel the backing paper from the bulkhead seal (N) and apply it to the top of the bulkhead. The seal should be flush with the inside face of the bulkhead and snug between the bed rail caps. Apply pressure to the entire seal to make sure the adhesion is good. Trim for a tight fit.

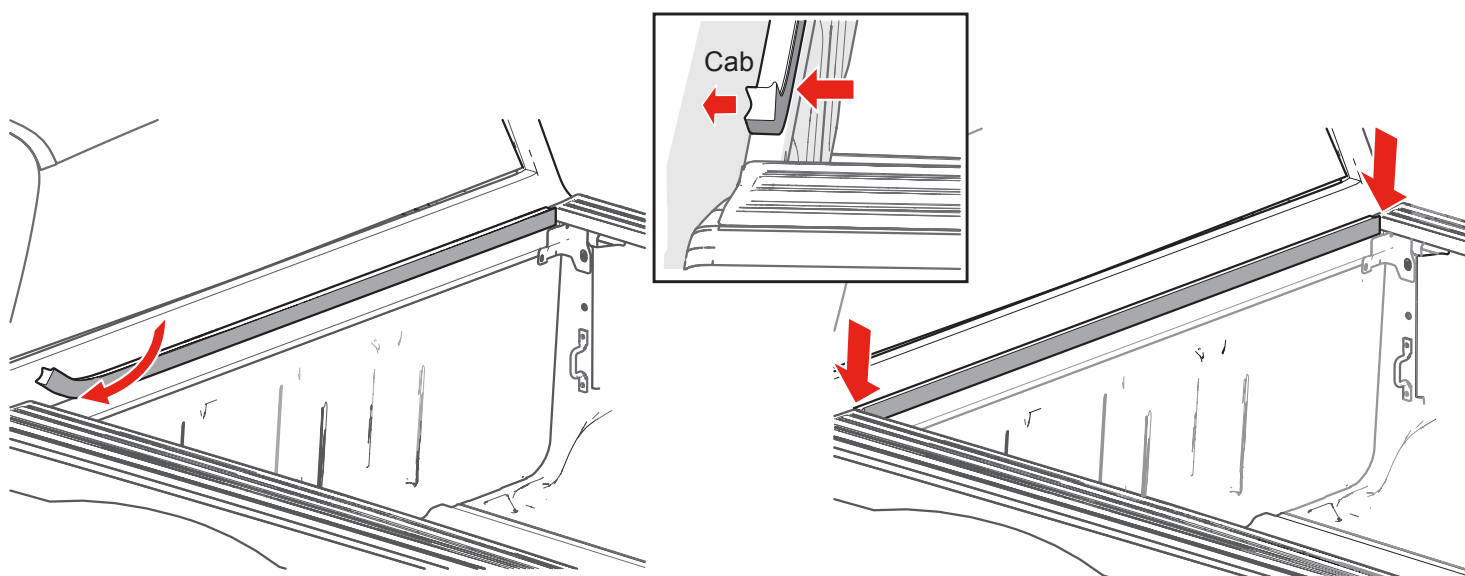

4 REAR mounting brackets. Install the rear bracket (C) to the truck bed rail near the tailgate. Measurement for the rear mounting bracket is $43\frac{5}{8}$ " from the back side of the bulkhead to the front edge of the bracket.

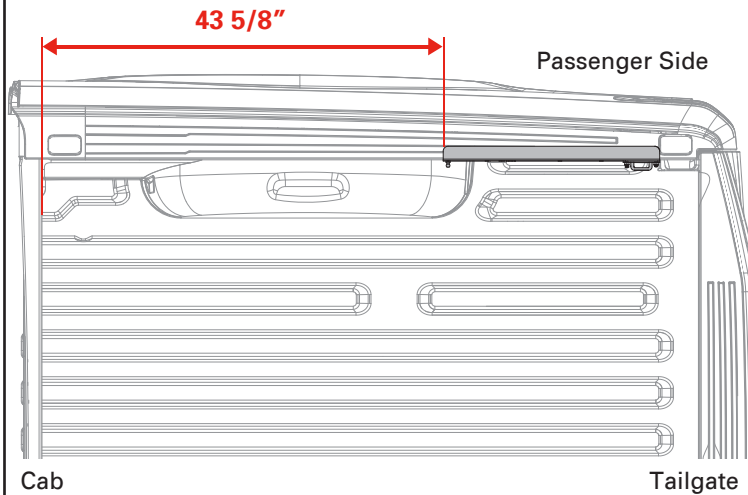

5 REAR mounting brackets spacers. Place two spacers (L) between the plastic bed rail cap and the metal truck rail at the clamp location for each rear bracket. Do **NOT** place over the top of the bosses (the raised area).

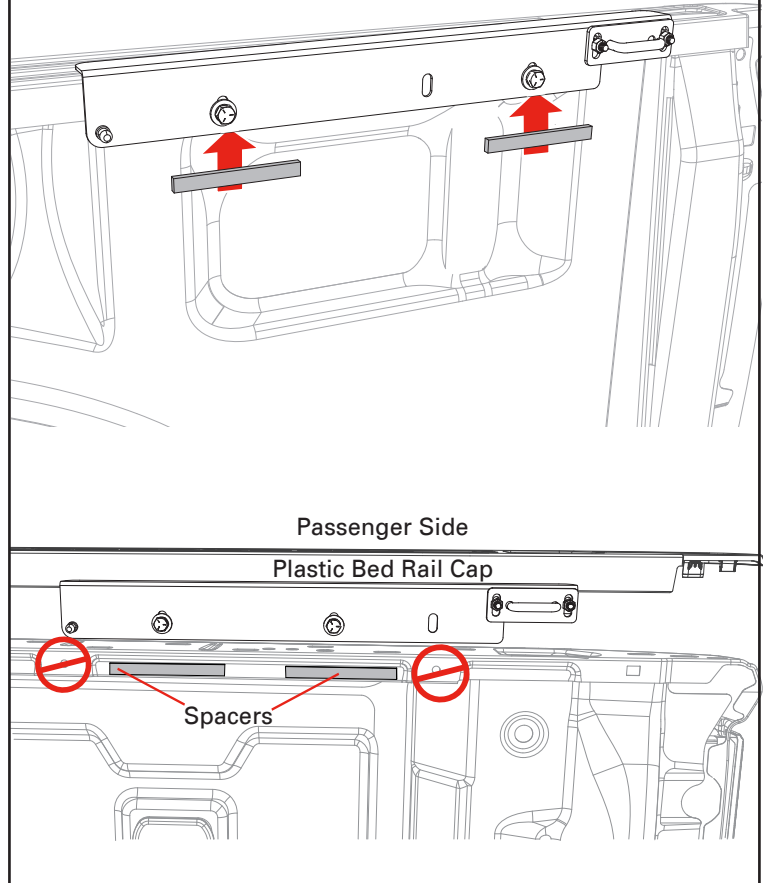

6 REAR mounting brackets. Use two clamps (E) per rear bracket (C). For each bracket, install one clamp in hole 1 by adding a bolt (F), washer (G), and lock washer (H) in this order, shown below. Then install another clamp in the hole nearest the tailgate that is not blocked by the truck bed. Do **NOT** overtighten and distort the brackets.

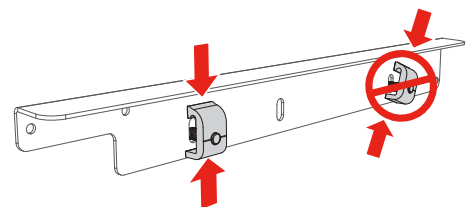
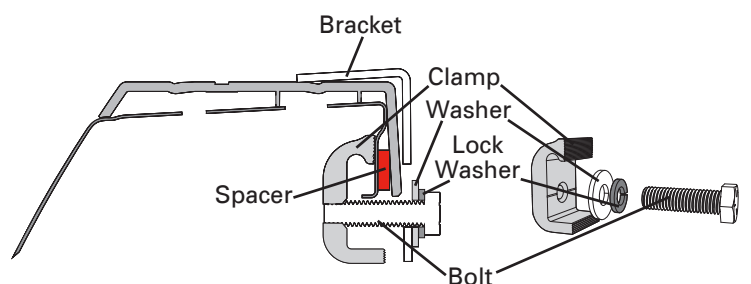
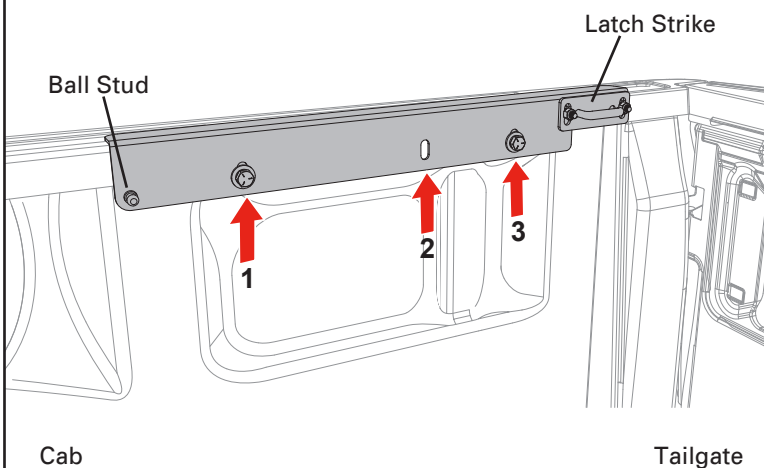

The clamps should be oriented straight up and down, NOT angled.

7 FRONT mounting brackets. Install the front bracket (B) to the truck bed rail near the bulkhead. Measurement for the front mounting bracket is **18"** from the back side of the bulkhead to the end of the bracket.

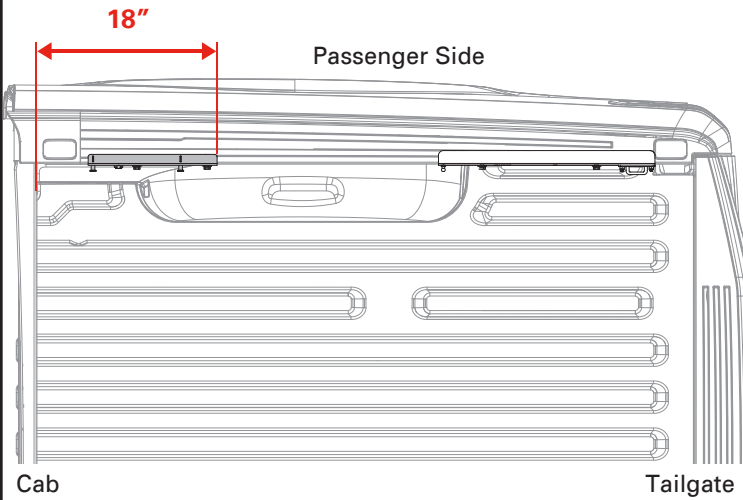

8 FRONT mounting brackets spacers. Place two spacers (L) between the plastic bed rail cap and the metal truck rail at the clamp location for each front bracket on either side of the boss (the raised area). Do **NOT** place over the top of the boss.

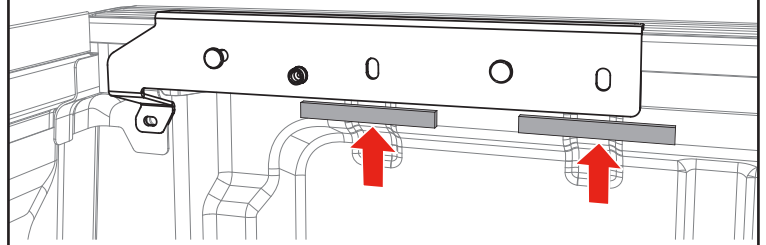

9 FRONT mounting brackets. Install one hex bolt (O) per front mounting bracket (B) through the top hole at the front corner of the bed. Then use two clamps (E) per front bracket, one per hole in each front mounting bracket. For each clamp add a bolt (F), washer (G), and lock washer (H) in this order, as shown below. *The fit of the cover to the truck bed is determined by the front mounting brackets. This measurement is a good starting point. Unfortunately, not all truck beds are assembled 100% square, so some adjustments may be necessary after the cover is set on the truck.*

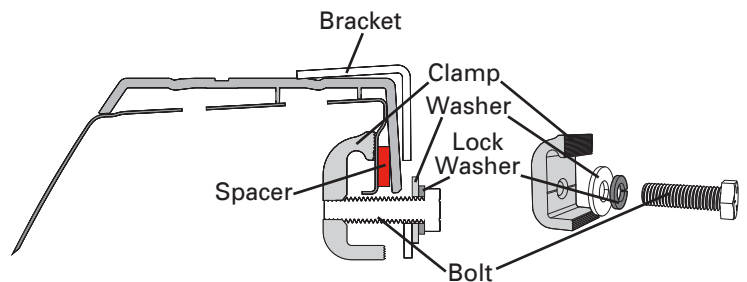
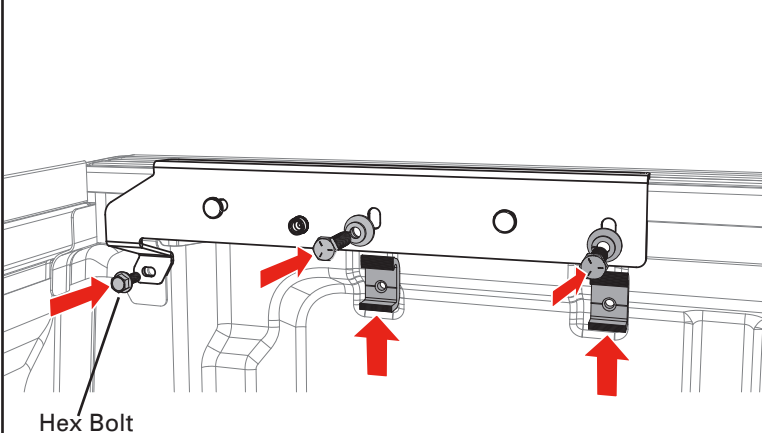

10 Install Cover. With some assistance, set the bed cover (A) on the truck bed. Slide the slots in the four bar hinges (K) (attached to the cover) over the posts on the front mounting brackets (B). Push the cover forward to lock the hinges to the mounting brackets.

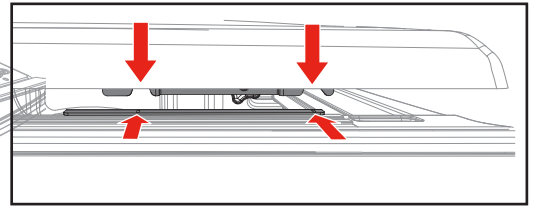
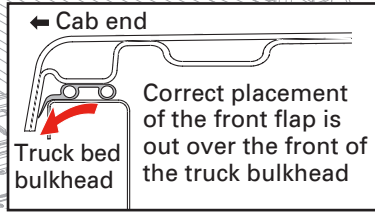
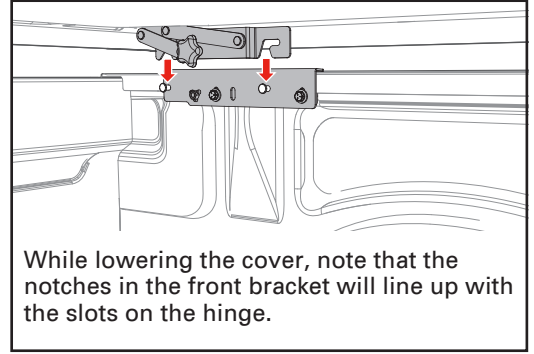
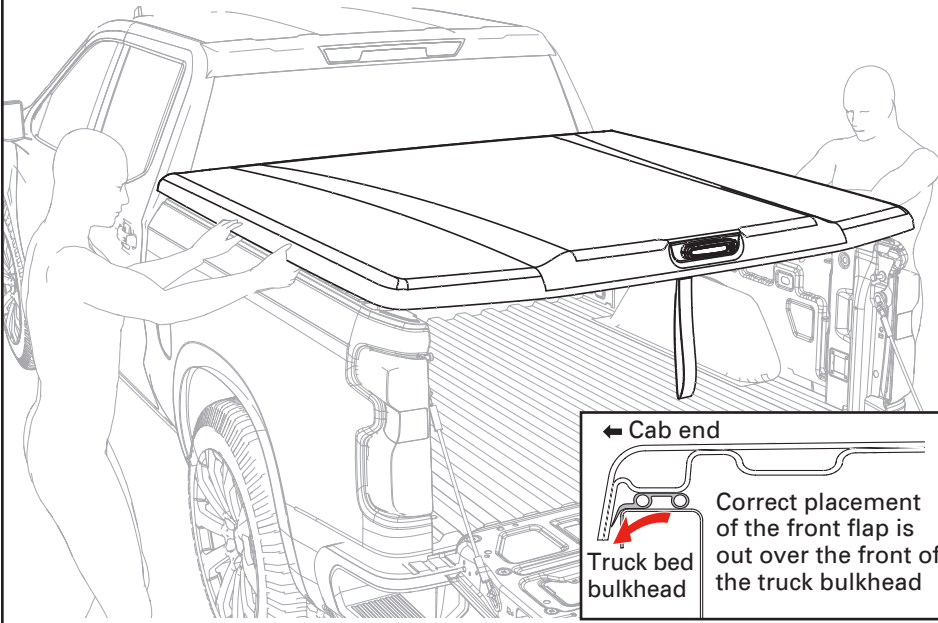

11 Install Cover. Once the cover (A) is in place tighten the twist knobs (K) on both the driver and passenger sides.

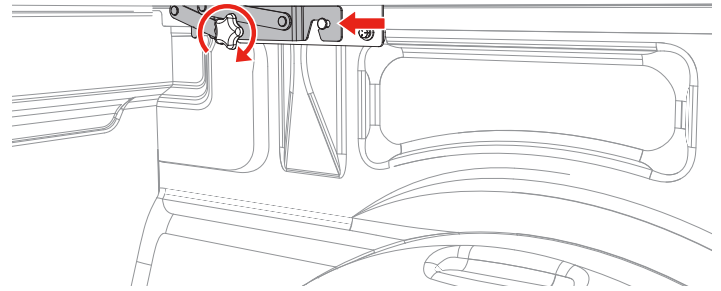
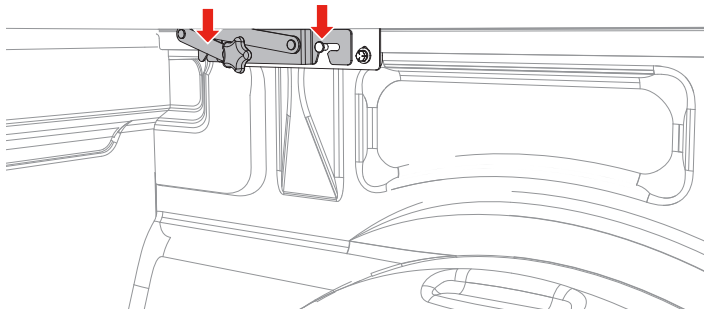

12 Install Cover. To install the hydraulic struts (D) attach the large cylinder end of the strut to the cover (A) and the rod end to the rear mounting bracket (C). They will snap into place, no tools are needed.

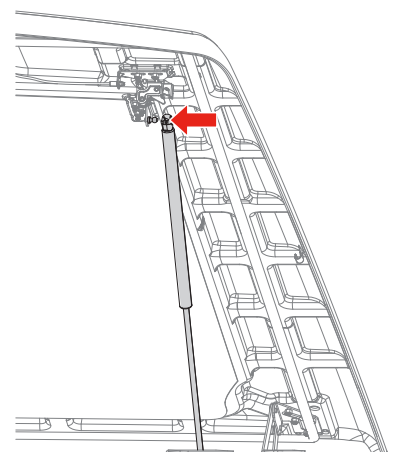
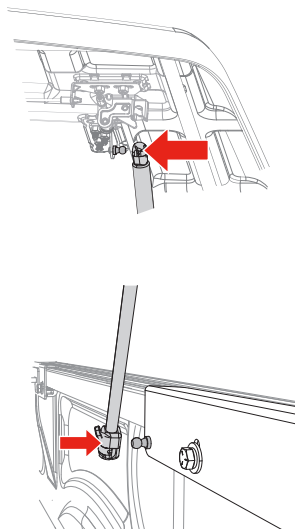
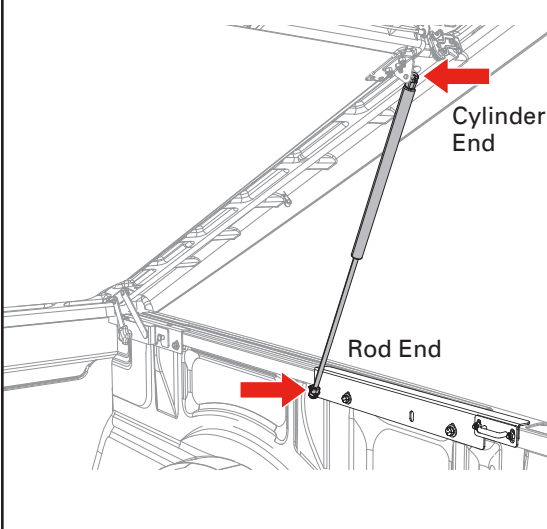

- 13 Install Cover.** With the cover (A) closed, check the fit to make sure it is not touching the bed on either side or the tailgate. The desirable gap is no less than 1/8" and no more than 3/8" to 1/2".

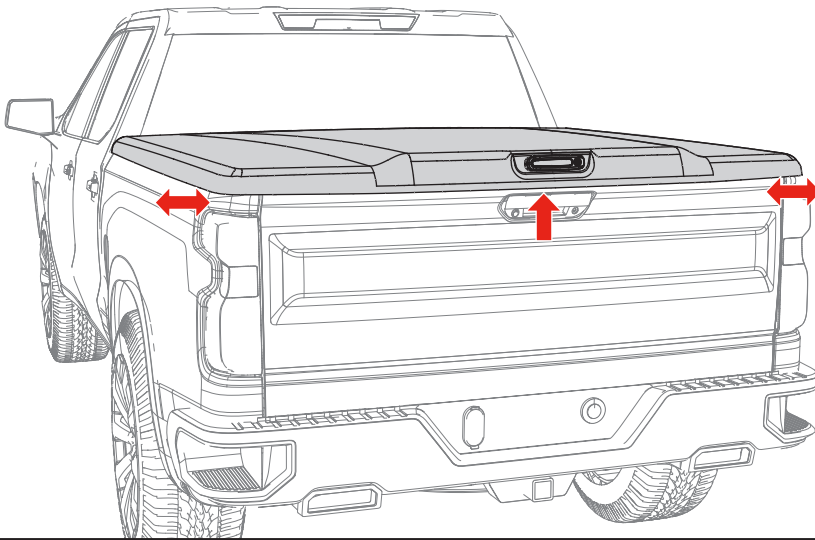

- 14 Install Cover.** To adjust the cover (A) from front to back to be more even, loosen the clamps (E) and move both of the front brackets (B) forward or rearward accordingly. To adjust to one side or the other, move the front brackets forward or rearward independently. Retighten all of the clamps.

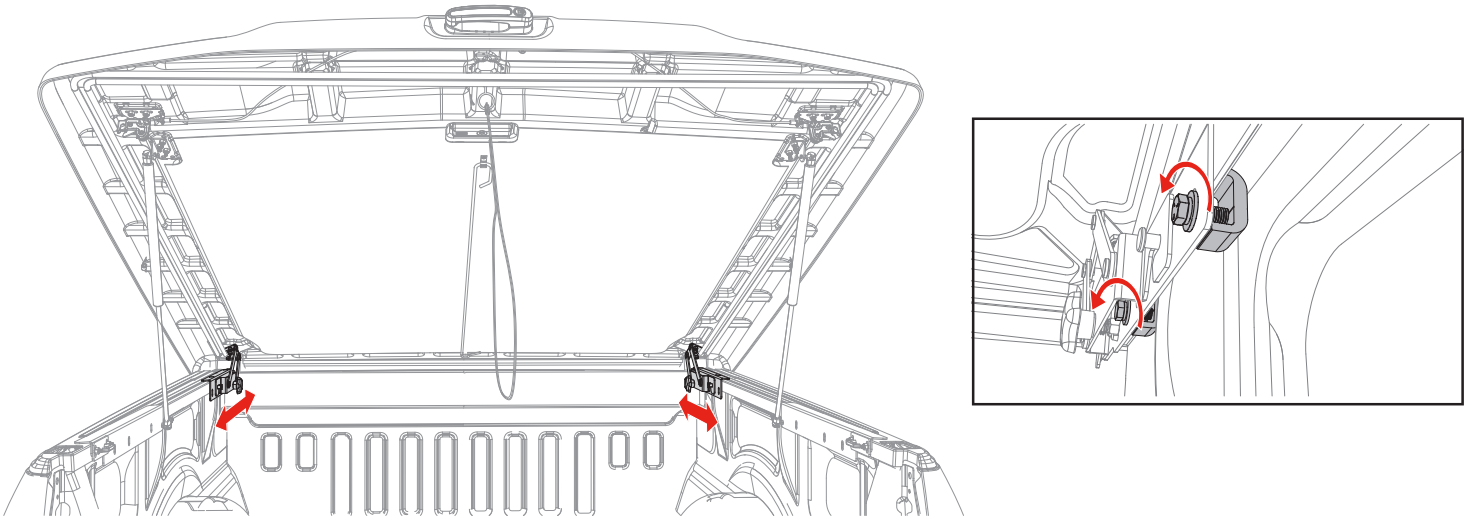

- 15 Final adjustments.** Be sure the front flap hangs over the bulkhead of the truck. The latch strike can be adjusted by loosening the two nuts and moving the strike up or down to make better contact with the latch. The rotary latch can be adjusted by loosening the two nuts and moving the latch in or out to make better contact with the strike.

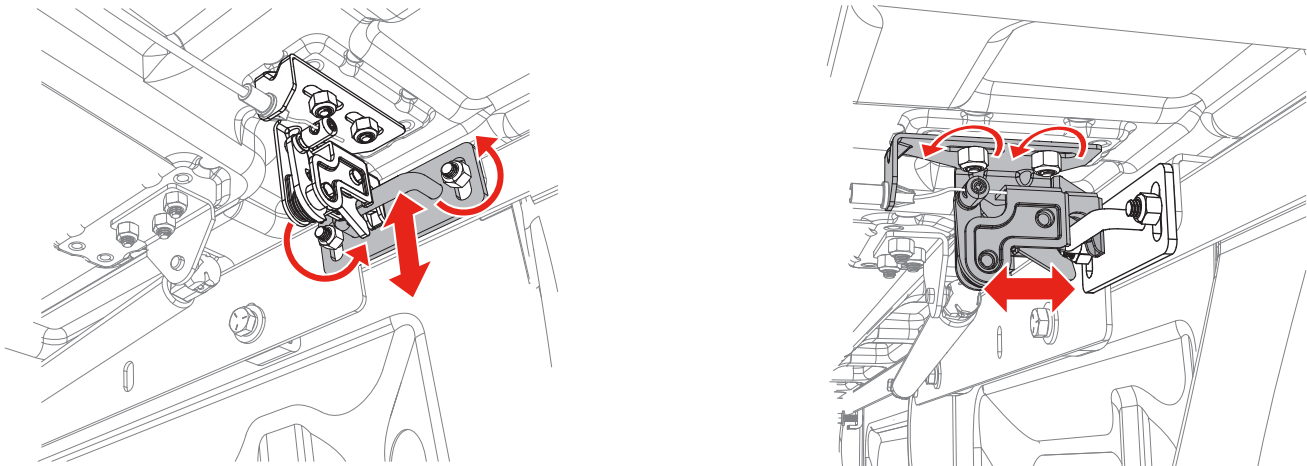

Removing the Cover

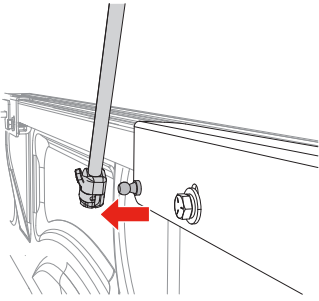

Release the strut (D) off of the ball stud, and be sure to secure the cover (A) to prevent it from closing unexpectedly.

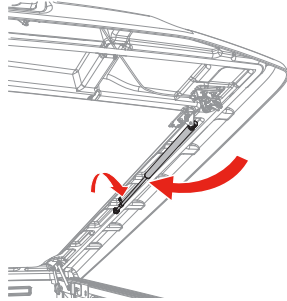

Place the loose end of the strut (D) in the storage clip. Repeat on the opposite side.

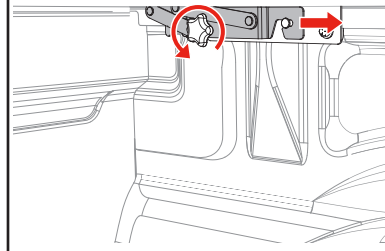

Then turn the twist knobs (K) until they release.

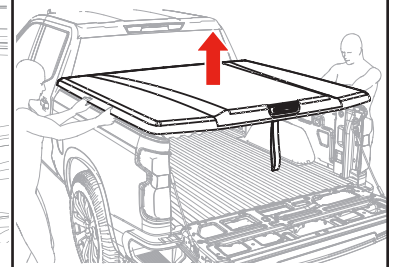

Next, pull the cover (A) rearward, releasing the hinge from the mounting brackets (B & C), and lift the cover off.

Re-Installing the Cover

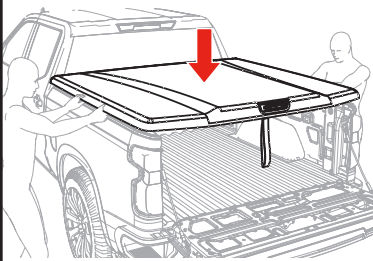

Place the truck bed cover (A) on the truck.

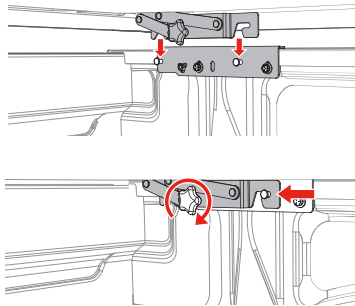

Slide the slots in the 4 bar hinges (attached to the cover) over the posts on the front mounting brackets. Then push the cover forward to lock the hinges to the mounting brackets.

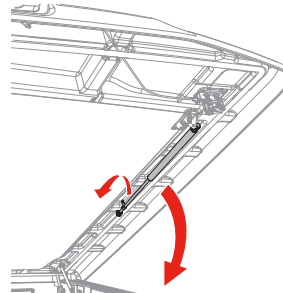

Lift the cover (A) from the rear and tighten the twist knobs (K) on both left and right hinges.

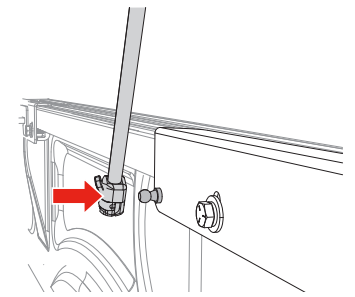

Next, re-install the struts (D).

Wall Hanging Instructions

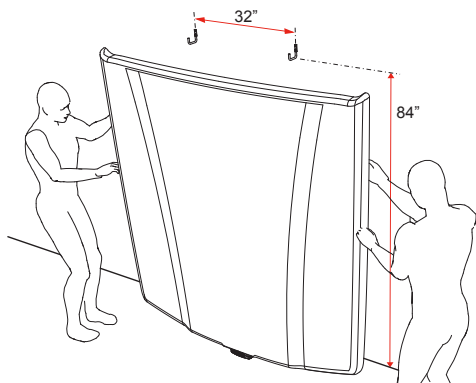

Before removing the cover (A), mount the two J-Hooks (I) with the mounting screws (J) provided, on the garage wall. The hooks must have a minimum height from the floor of 84". Center horizontally 32" apart from each other. For long bed trucks mount 98" from the floor. Then remove the cover from the truck bed.

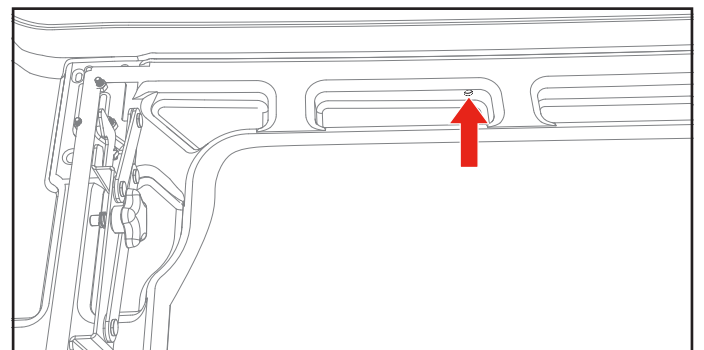

Finally, hang the cover vertically by locating the two holes on the underside of the cover. With the cover facing away from the wall, carefully align the holes in the cover with the hooks on the wall. Gently lift the cover and slide the hooks through the holes until they are fully inserted.

LIMITED WARRANTY

Thank you for purchasing your RealTruck | A.R.E. LS3 truck bed cover! We value your business and believe you will enjoy your new product. Please review this Limited Warranty.

TERMS OF THIS WARRANTY: Please note the following:

- RealTruck | A.R.E. warrants the ABS polymer structure of your truck bed cover to be structurally free from defects in material and workmanship for life.
- The lock cylinder, keyless entry, and lock housing are warranted for three (3) years from your retail date of purchase against failure due to defects in material and workmanship.
- Gas props used to assist in opening the cover are covered for five (5) years from your retail date of purchase against failure due to loss of pressure.
- This Limited Warranty: (i) applies only to the original purchaser; (ii) applies only when purchased from an authorized ARE dealer; and (iii) is nontransferable.
- Your original sales receipt will serve as proof of purchase for this Limited Warranty.
- This Limited Warranty only applies to the original truck or original installation.
- Before credit can be issued on a warranty claim, proof of defect may be required in the form of pictures. This will be determined at the time of claim.

EXCLUSIONS OF THIS WARRANTY: This Limited Warranty does not cover any damage or issue due to or caused by: (i) transportation; (ii) storage; (iii) improper use and / or installation, including, but not limited to, operating your truck with your RealTruck | A.R.E. cover in the open position; (iv) failure to follow the product instructions or to perform any preventive maintenance; (v) alterations or modifications, including, but not limited to, any alterations or modifications to installation hardware and / or addition of equipment; (vi) unauthorized repair; (vii) normal wear and tear; or (viii) external causes such as accidents, abuse, neglect, use of improper cleaning materials, lack of maintenance, or other actions or events beyond our reasonable control. Any damage or issues caused by any of the foregoing remain the owner's sole responsibility.

CAUTION: Please note and ensure your compliance with the following, as failure to comply will void this Limited Warranty:

- Do not attempt to drive with your cover in the open position.
- Do not tie down your cover while in the open position. Tying the cover down when open will cause severe stress to the front hinges and could cause one or both hinges to crack and possibly tear out. This type of damage is not considered a manufacturer defect.
- When in the closed position, your truck bed cover must be locked and the tailgate must be closed. Failure to do so could result in sudden opening of the tonneau cover from unexpected heavy winds, which could cause damage to the truck and / or your tonneau cover.
- Do NOT tow your vehicle from the rear with the cover on your vehicle. If towing from the rear is required, the cover must be removed from the vehicle and properly stored.
- When hauling material that is taller than the truck bed height, you should remove the cover, store it, then properly haul oversized material.
- Inspect your truck periodically for rubbing. If you notice any rubbing, immediately remove the cover and contact your dealer. A bracket adjustment may be necessary to protect from further damage.
- Paint damage is not covered under this Limited Warranty and is the sole responsibility of the truck owner. Paint protective films may be used to help prevent possible paint damage. Ask your dealer for other recommendations. It is the responsibility of the truck owner to report any damage that is occurring to the owner's dealer. This will greatly limit any damage and make needed repairs much less extensive.
- Never wipe the shaft of the gas props with anything other than a dry soft cloth. Regular operation of the gas props will actually increase the life by lubricating the seals and shafts.

MAINTENANCE & CARE: The ABS polymer body of your RealTruck | A.R.E. product requires only periodic cleaning with mild car wash soap. **ONLY USE CLEANERS, WAXES, OR PRODUCTS THAT ARE LABELED, "Safe for use on plastics"** (or similarly labeled as appropriate for use on plastics). Do not let chemicals or substances come into contact with your truck bed cover unless labeled "Safe for plastics" (or similarly labeled as appropriate for use on plastics). Avoid use of abrasive type cleaners as they may cause major damage and / or discoloration.

WARRANTY CLAIMS: In the event of a warranted product failure, it is RealTruck | A.R.E.'s discretion to repair or replace the defective part(s). RealTruck | A.R.E. reserves the right to replace any parts with current production parts of equal or greater quality and value. All repairs must be made by an authorized RealTruck | A.R.E. dealer. All claims must be made to the authorized

RealTruck | A.R.E. dealer from whom / from which you purchased your product. If you have relocated and / or are unable to return to the RealTruck | A.R.E. dealer where you made your purchase, call (800) 649-4ARE or visit www.4are.com for the nearest authorized dealer. The authorized dealer will process your claim and make the necessary repairs or replacements. Personal identification along with proof of purchase and ownership of the original pickup and RealTruck | A.R.E. product are required for all warranty claims.

Be sure to register your RealTruck | A.R.E. product at www.4are.com/register within one (1) month of the date of purchase. Registration also qualifies you to receive future premiums and new product information.

LIMITATION OF LIABILITY: THE REMEDIES DESCRIBED ABOVE ARE YOUR SOLE AND EXCLUSIVE REMEDIES AND OUR ENTIRE LIABILITY FOR ANY BREACH OF THIS LIMITED WARRANTY. OUR LIABILITY SHALL UNDER NO CIRCUMSTANCES EXCEED THE ACTUAL AMOUNT PAID BY YOU FOR THE DEFECTIVE PRODUCT, NOR SHALL WE UNDER ANY CIRCUMSTANCES BE LIABLE FOR ANY CONSEQUENTIAL, INCIDENTAL, SPECIAL, OR PUNITIVE DAMAGES OR LOSSES, WHETHER DIRECT OR INDIRECT.

SOME STATES DO NOT ALLOW THE EXCLUSION OR LIMITATION OF INCIDENTAL OR CONSEQUENTIAL DAMAGES, SO THE ABOVE LIMITATION OR EXCLUSION MAY NOT APPLY TO YOU.

**REGISTER
YOUR
WARRANTY
ONLINE**



SAFETY INSTRUCTIONS

- DO NOT place objects on or against cover or framework.
- DO NOT tie cargo to truck bed cover or framework.
- DO NOT operate vehicle with objects on top of the cover.
- NEVER allow children or pets to occupy the truck bed with the cover in the fully closed position.
- The cover is not airtight. Special care is required to keep cargo clean and dry.
- Truck bed covers will not prevent theft of contents inside the truck bed.

TROUBLESHOOTING TIPS

Cover not resting square on the bed: As not all beds are square, adjustment to one of the front brackets may be necessary. If you notice a rear corner with an inconsistent gap, move that front bracket towards the tailgate in 1/8" increments until equal gapping is achieved throughout the truck bed cover.

Rear latches not engaging: If the rear latches are not engaging when the cover is being shut, the rear latch strikes need to be moved up or down or the rear rotary latch may need to be adjusted. These both can be done by loosening the nuts and adjusting the rotary latches or latch strikes accordingly.