



D2644 Installation Instructions 2025 Ram 1500 4wd 4-6" Suspension Systems

Read and understand all instructions and warnings prior to installation of product and operation of vehicle.

Zone Offroad Products recommends this system be installed by a professional technician. In addition to these instructions, professional knowledge of disassembly/ reassembly procedures and post installation checks must be known. Minimum tool requirements include the following: Assorted metric and standard wrenches, hammer, hydraulic floor jack and a set of jack stands. See the "Special Tools Required" section for additional tools needed to complete this installation properly and safely.

» PRODUCT SAFETY WARNING

Certain Zone Suspension Products are intended to improve off-road performance. Modifying your vehicle for off-road use may result in the vehicle handling differently than a factory equipped vehicle. Extreme care must be used to prevent loss of control or vehicle rollover. Failure to drive your modified vehicle safely may result in serious injury or death. Zone Offroad Products does not recommend the combined use of suspension lifts, body lifts, or other lifting devices.

You should never operate your modified vehicle under the influence of alcohol or drugs. Always drive your modified vehicle at reduced speeds to ensure your ability to control your vehicle under all driving conditions. Always wear your seat belt.

» TECHNICAL SUPPORT

www.zoneoffroad.com may have additional information about this product including the latest instructions, videos, photos, etc.

Send an e-mail to tech-zone@ridefox.com detailing your issue for a quick response.

888.998.ZONE Call to speak directly with Zone tech support.

» PRE-INSTALLATION NOTES

1. Special literature required: OE Service Manual for model/year of vehicle. Refer to manual for proper disassembly/reassembly procedures of OE and related components.
2. Adhere to recommendations when replacement fasteners, retainers and keepers are called out in the OE manual.
3. Larger rim and tire combinations may increase leverage on suspension, steering, and related components. When selecting combinations larger than OE, consider the additional stress you could be inducing on the OE and related components.
4. Post suspension system vehicles may experience drive line vibrations. Angles may require tuning, slider on shaft may require replacement, shafts may need to be lengthened or trued, and U-joints may need to be replaced.
5. Secure and properly block vehicle prior to installation of Zone Offroad Products. Always wear safety glasses when using power tools.
6. If installation is to be performed without a hoist, Zone Offroad Products recommends rear alterations first.
7. Due to payload options and initial ride height variances, the amount of lift is a base figure. Final ride height dimensions may vary in accordance to original vehicle attitude. Always measure the attitude prior to beginning installation.
8. 18IN WHEELS MAXIMUM RECOMMENDED BACKSPACING IS 4.5". TEST FIT WHEELS ON VEHICLE BEFORE MOUNTING TIRES TO ENSURE WHEEL BARREL CLEARANCE. ADHESIVE WHEEL WEIGHTS MUST BE USED.

Difficulty Level

Easy 1 2 **3** 4 5

Estimated installation: 8 hours

Tire/Wheel Fitment

4" system:

- 35 x 12.50 x 20 w/ 5" back-space, some trimming may be required

- 35 x 12.50 x 20 w/5.5" back-space, some trimming may be required

**18" wheels, 4.5" max back-space, test fit wheel before mounting tires. See Note 8

6" system:

- 37 x 12.50 x 20 w/ 5" back-space, trimming is required.

- 37 x 12.50 x 20 w/ 5.5" back-space, trimming is required.

**18" wheels, 4.5" max back-space, test fit wheel before mounting tires. See Note 8.

ZOND5802 Bumper Spacer Kit (sold separately) recommended for additional tire-to-front fender clearance.

***Important* Verify you have all of the kit components before beginning installation.**

Kit Contents

Qty	Part	Qty	Part
1	Steering Knuckle DRV	1	Differential Drop Brkt DRV rear - 3.6L
1	Steering Knuckle PASS	1	Sway Bar Drop DRV
2	Tie Rod Ends	8	Offset Cam Washer
1	Bolt Pack - Diff hardware	1	Sway Bar Drop Pass
1	Bolt Pack - Sway Bar Drop	1	Front Driveshaft Spacer
1	Bolt Pack - Brake hardware/Strut Spacer	1	Differential Skid Plate
1	Bolt Pack - Main bolt pack	2	Rear Coils Springs
1	Bolt Pack - Diff bolt replacement	1	Track Bar Brkt
1	Bolt Pack - Upper Ball Joint Washer	1	Track Bar Spacer Sleeve
1	Bolt Pack - Large Bearing ABS spacer	1	Nut Tab - Bump Stop
1	Front Crossmember	1	Upper Relo. brkt - DRV
1	Zone Logo/Hardware	1	Upper Relo. brkt - PASS
1	Rear Crossmember	2	Relo. Bracket Spacer Sleeve
4	18mm x 150mm bolt	2	Bumpstop Spacers
4	18mm Nut	2	Sway Bar Link
8	Cam Slot Washer	4	Sway Bar Bushings
2	Front Brake Line Bracket	4	Sway Bar Sleeves
2	Preload spacer (6" kits only)	1	Bolt Pack - Bumpstops
2	Strut Spacer	1	Bolt Pack - Sway Bar Link
1	Differential Drop Brkt PASS	1	Bolt Pack - Main Pack
1	Differential Drop Brkt DRV front	2	Shock Nut Tab
1	Differential Drop Brkt DRV rear - 3.0L	2	Rear Brakeline Bracket

IMPORTANT

It is required that ride height measurements be taken before and after installation. Measure from the **WHEEL AXLE CENTER** up to the **FENDER LIP** of the wheel opening. Do this for all 4 wheels. Record measurements below.**

BEFORE:

LF _____ RF _____ LR _____ RR _____

AFTER:

LF _____ RF _____ LR _____ RR _____



****These ride heights will be required if you have any ride height concerns after installation. Please be prepared to provide these to Technical Support.**

PRE-INSTALLATION NOTES

1. Will not fit air ride equipped models
2. Ensure you have the proper knuckles before proceeding. Vehicle equipped with 22" wheels from the factory have a larger bearing and required D2662 and D2663 knuckle box kits. All others use D2660, D2661 box kits.
3. Special Tools: 35mm Axle Nut Socket, T30 Torx bit, universal joint/swivel sockets, ball joint separator, ratcheting wrench set

INSTALLATION INSTRUCTIONS

» FRONT INSTALLATION

4. Park the vehicle on a clean, flat surface and block the rear wheels for safety.
5. Disconnect BOTH batteries (if equipped), Main and Auxiliary, using a 10mm socket and or wrench. Cover the battery terminals to prevent electric arc. Fig. 1, 2



Figure 1

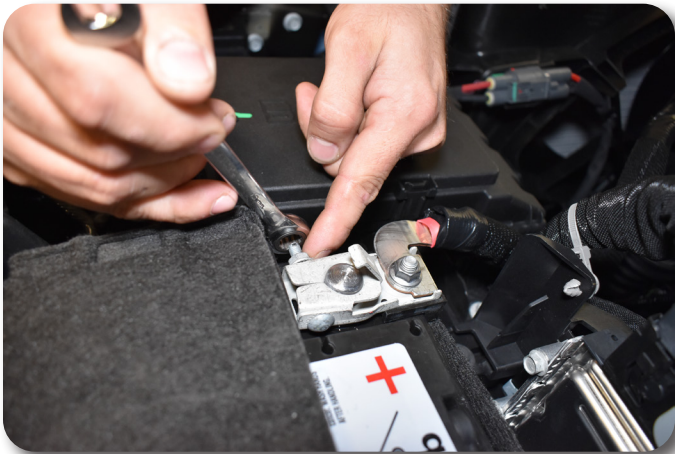

Figure 2

6. Raise the front of the vehicle and support with jack stands under the frame rails.
7. Remove the wheels.
8. Disconnect the front sway bar links from the control arm using an 18mm socket. Fig 3.



Figure 3

9. Remove and discard the factory front skid plate, if equipped.
10. Disconnect the tie rod ends from the steering knuckles. Remove and retain the mounting nuts. Use the appropriate puller to separate the tie rod end from the steering knuckle. Take care not to damage the tie rod end.
11. Disconnect the ABS brake line at the frame. Remove it from any retaining clips.
12. Disconnect the brakeline hardware from the strut tower and pull the brakeline through the mount. Cut a slot to allow the brakeline to be removed from the frame. If you do not wish to cut on the coil bucket, the line can be disconnected and reconnected after it is removed from the frame. If the line is disconnected the brakes must be bled once the installation is completed. Fig. 4

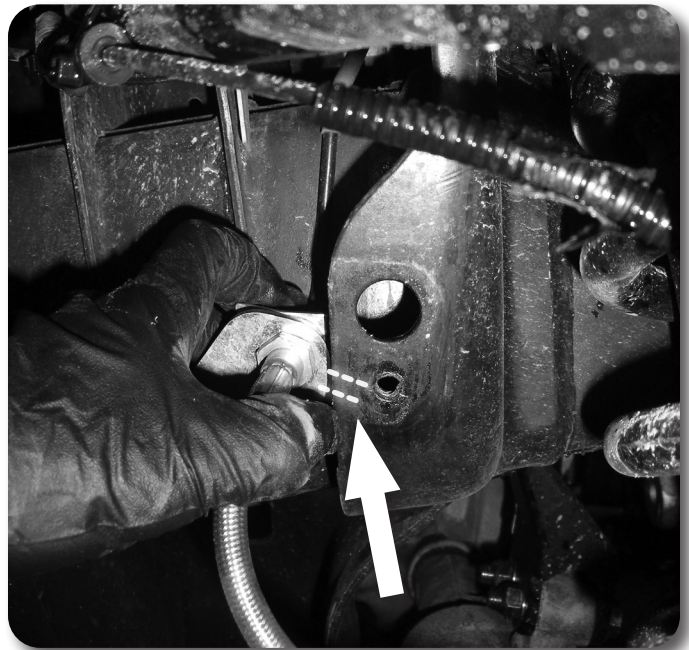

Figure 4

Step 13-14 Note

The brakeline drop hardware is located in bolt pack 470 & 481.

13. Attach the provided brake line relocation bracket to the frame where the original line mounted. Torque the factory bolt to 15 ft-lbs and the 1/2" bolt to 56 ft-lbs.

- Carefully reform the hardline to gain additional length. Attach to the relocation bracket with 5/16" x 3/4" bolt, nut, and washers. Torque to 13 ft-lbs. Fig. 5.

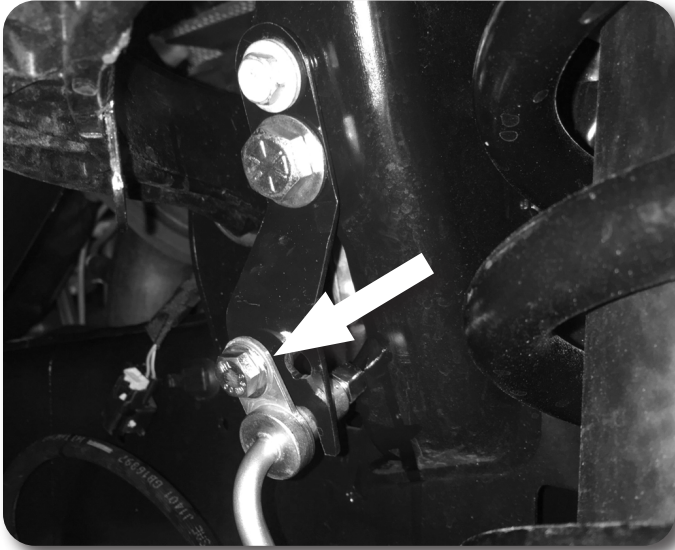

Figure 5

- Repeat brake line relocation bracket installation on the passenger's side of the vehicle.
- Remove the brake caliper bracket to knuckle bolts Fig. 6 and pull the caliper free from the steering knuckle and rotor. Hang the caliper securely out of the way. Retain caliper mounting hardware. .

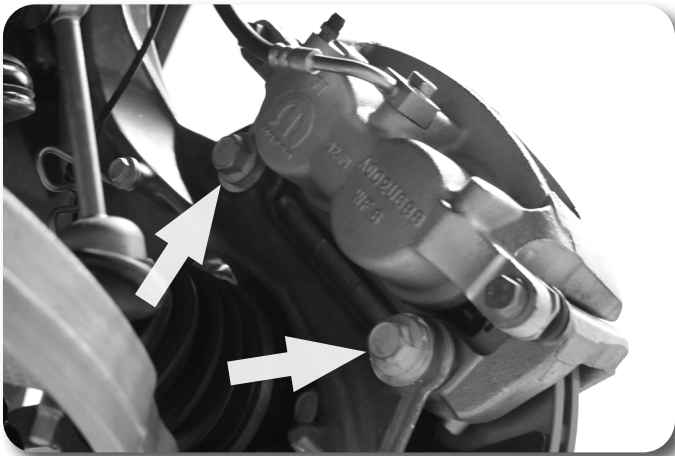

Figure 6

- Remove the brake rotor torx (T30) screw and rotor from the hub.
- Remove the hub axle nut (35mm). Retain nut.
- Remove the ABS sensor from the knuckle and route the sensor away from the knuckle. Save mounting bolt.
- Loosen but do not remove the lower control arm bolts.
- Support the lower control arm with a hydraulic jack. Remove the three strut-to-frame mounting nuts Fig. 7 DO NOT loosen the middle strut nut.

Step 16 Note

Do not allow the brake caliper to hang from the brake hose.

Figure 7 Note

DO NOT REMOVE CENTER NUT

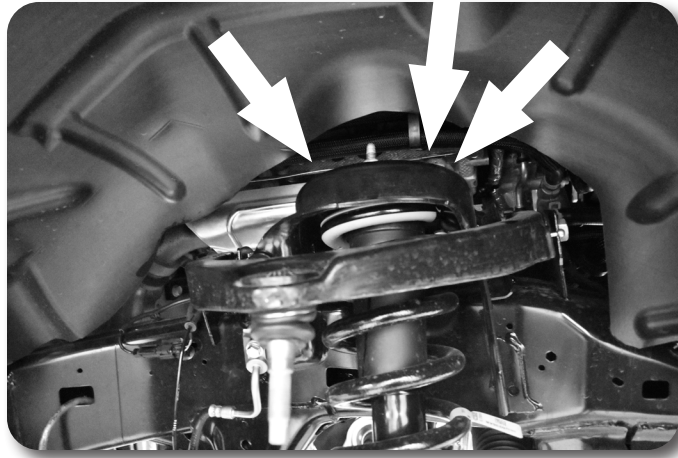

Figure 7

22. Loosen the strut-to-lower control arm hardware Fig. 8. Remove the nut from the bolt and leave the bolt in place to temporarily retain the strut to the lower control arm. Retain the nut.

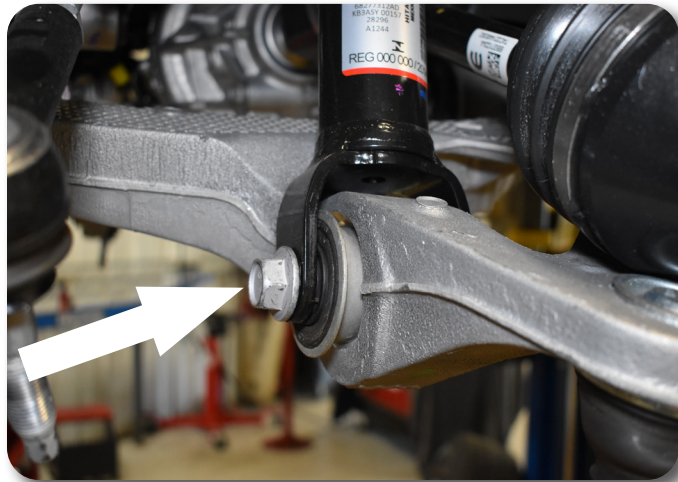

Figure 8

23. Remove the upper and lower ball joint nuts. Reinstall the nuts a few turns by hand. Separate the upper and lower ball joints from the steering knuckle using the appropriate puller. Take care not to damage the ball joint.
24. Remove the upper ball joint nut. Lower the jack enough to allow removal of the strut. Remove the lower strut bolt and remove the strut from the vehicle. Mark the strut from the appropriate side driver's or passenger's. Retain mounting bolt and upper ball joint nuts.
25. Continue to lower the jack allowing the knuckle/CV axle and lower control arm to swing down. Slide the CV axle off of the differential. Remove the CV axle from hub.
26. Remove the lower ball joint nut and remove the knuckle from the lower control arm. Retain the lower ball joint nut.
27. Remove the three bolts mounting the hub bearing assembly to the steering knuckle. Retain the mounting bolts and note dust shield orientation to the knuckle. Remove the hub assembly and dust shield from the knuckle.
28. Install the hubs in the corresponding new knuckles and fasten with the stock mounting bolts Fig. 9. Index the dust shield in the same orientation as the OE knuckle and install (ABS line runs out the front toward the steering arm). Use thread locker on the hub bearing bolt threads and torque to 37 +165° ft-lbs.



Figure 9

29. Remove the lower control arms from the frame. Retain hardware and eccentric cams.
30. Make indexing marks on the front driveshaft and differential input flange for realignment later. Remove the four bolts and disconnect the drive shaft from the differential. Support the driveshaft to keep the CV boot from binding. Discard mounting bolts.
31. Remove sway bar mounts from frame and remove sway bar assembly. Retain hardware.
32. Remove the four bolts mounting the OE rear crossmember Fig. 10 to the frame rails and remove the crossmember from the vehicle. Discard the crossmember and hardware.

Step 30 Note

Failure to support the driveshaft can lead to pinching the rubber boot at the CV joint which can damage the seal causing a leak and premature wear on the joint.



Figure 10

» **DIFFERENTIAL REMOVAL**

33. For 2025 model year, it is recommended the steering rack be removed to aid in removal of the front differential.

Step 34 Note

IMPORTANT!! Ensure steering wheel is positioned so both front wheels are straight forwards. Lock steering wheel in place before working on the steering rack.

Ensure steering wheel is positioned so both front wheels are straight forwards. Lock steering wheel in place before working on the steering rack.

34. Disconnect the four plugs from the steering rack. Fig. 11

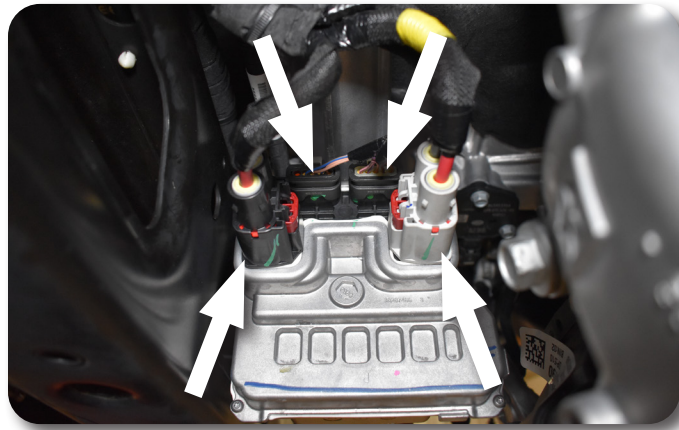

Figure 11

35. Disconnect the steering rack wiring harness from frame with a trim tool and reposition harness plugs up and out of the way. Fig. 12



Figure 12

36. Disconnect intermediate steering shaft to steering gear pinch bolt. Fig. 13 Save bolt for reinstallation.



Figure 13

Step 36 Note

Bolt should be accessible if steering wheel is in wheels-straight forward orientation.

37. Support the steering rack and remove the two mounting bolts at the front cross-member. Save for reinstallation. Fig. 14

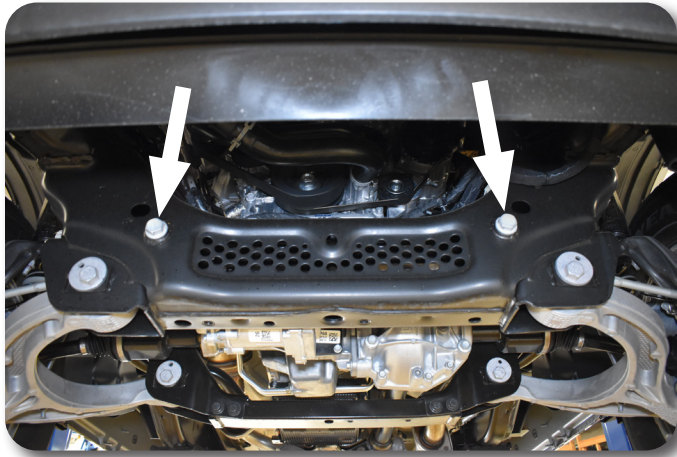

Figure 14

38. Disconnect the Front Axle Disconnect (FAD) wire harness connector and wire clips at the frame. Fig. 15, 16

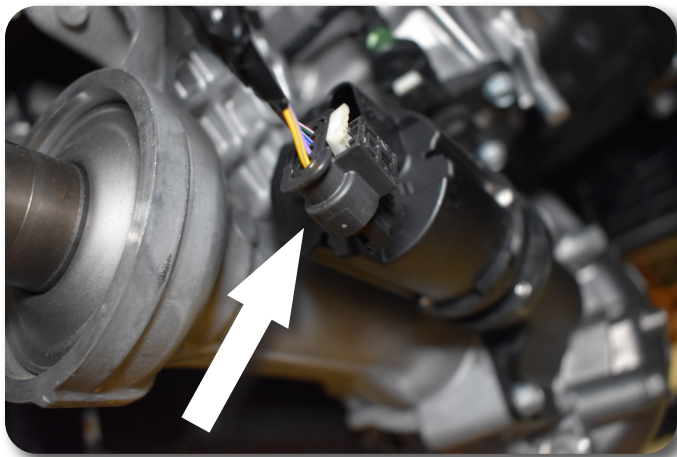

Figure 15



Figure 16

Step 40 Note

Trucks with 3.6L V6 do not need to disconnect the transmission coolant lines to gain better access to differential.

39. For 2025 trucks equipped with 3.0L I6 Hurricane engines, follow Steps 40-44. For 2025 trucks equipped with 3.6L V6 Pentastar engines, follow Steps 45-47.
40. **Trucks with 3.0L I6 Hurricane Engines:** Disconnect three transmission coolant line brackets to allow better access when removing the differential mounting bolts. Front bracket uses a 13mm wrench or deepwell socket, and a 6" minimum extension. Fig. 17, 18. Start at the first bracket near the A/C compressor following the lines rearward. Save hardware for reinstallation.

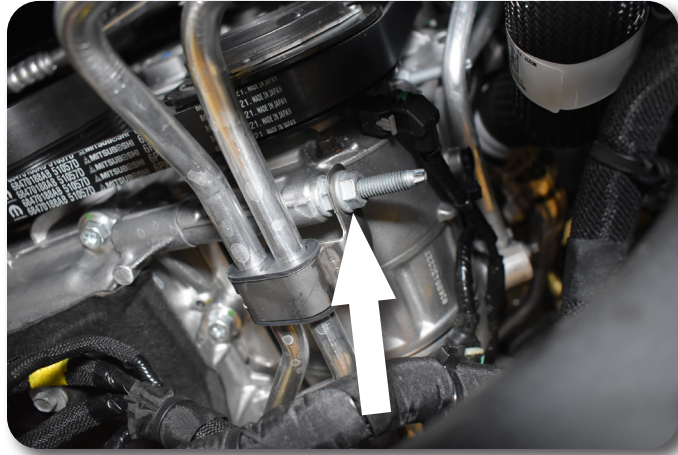

Figure 17

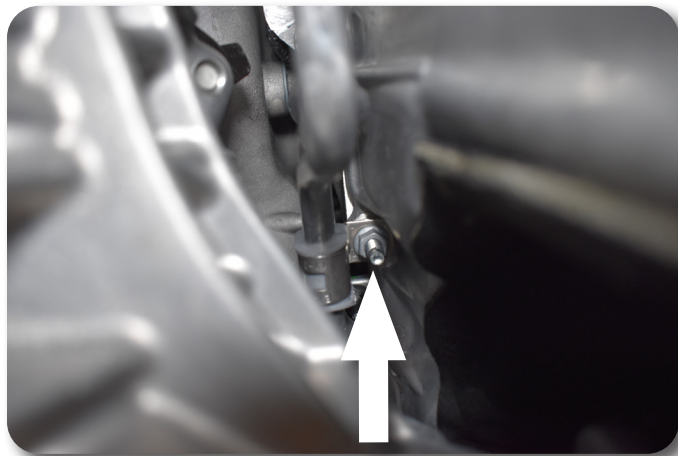
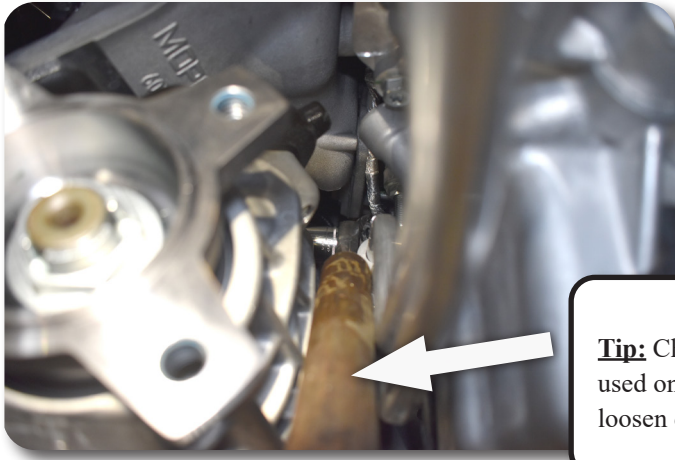

Figure 18

Step 41 Note

Bolt is too long to run out all the way with a ratchet, and will become lodged in place.

41. Remove two upper differential bolts using a 18mm chrome short socket and a cheater bar to break free. Loosen the bolt half way, then switch to an 18mm swivel ratcheting wrench. Remove the front bolt using an 18mm chrome short socket.. Fig. 19, 20



Tip: Cheater bar can be used on ratcheting wrench to loosen differential mounting bolts.

Figure 19

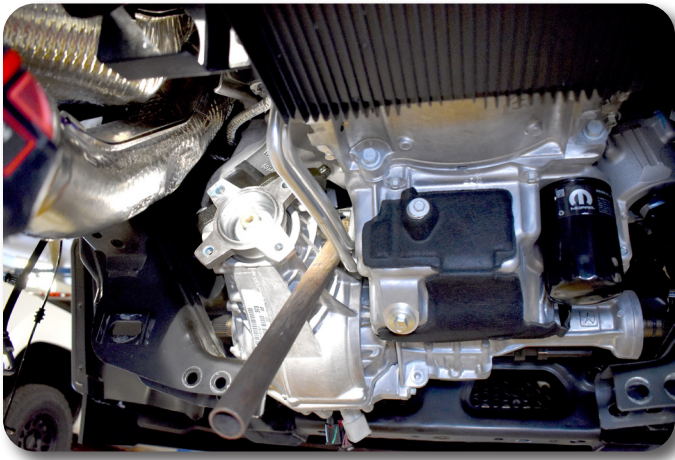

Figure 20

42. If vehicle is on a hoist, place a transmission jack under the differential. If working on the ground, support the differential with a floor jack.
43. Remove the three rear differential bolts at the housing using a 12" extension with 19mm short socket, swivels at both impact and socket. Access is best from the wheel well, over the frame. Fig. 21, 22

Step 43 Note

Have an assistant help guide sockets to bolt heads as necessary.

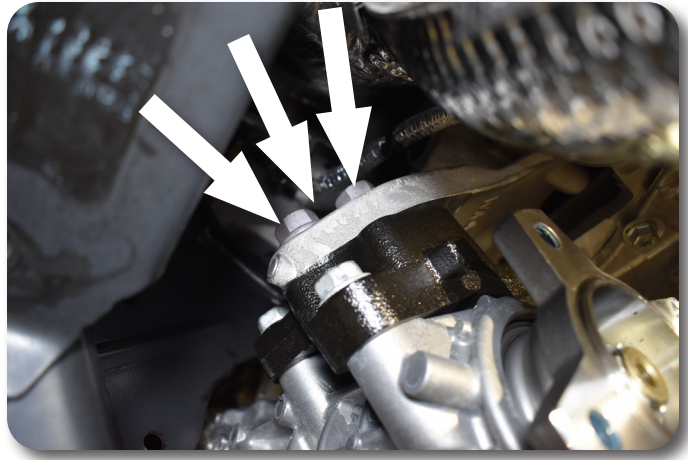

Figure 21



Figure 22

44. Remove two front differential bolts (passenger side) using an 18mm socket. It may be necessary to loosen with an impact then complete removal with a ratchet. Fig. 23 Securely support the differential and lower from the vehicle.

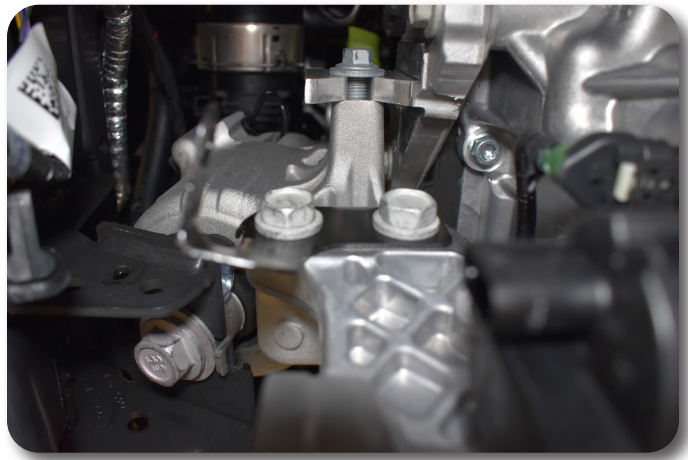

Figure 23

45. **3.6L V6 Pentastar engines** Loosen but do not remove the three rear driver's side bolts Figure 24 and the two passenger's side bolts Figure 25. On the passenger's side, if equipped, remove the differential actuator cable bracket, It will not be reused. Disconnect the wiring connector from the differential.



Figure 24

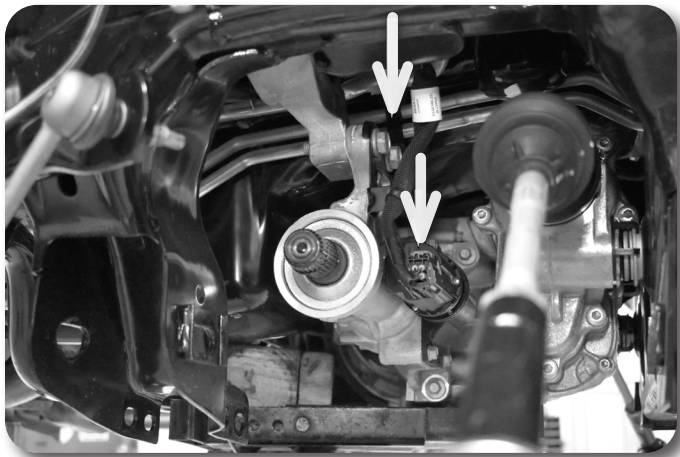

Figure 25

46. Ensure the differential is supported. Loosen and remove the two forward-most differential mounting bolts on the driver's side, manipulating the wiring harness location in order to gain clearance. Fig. 26

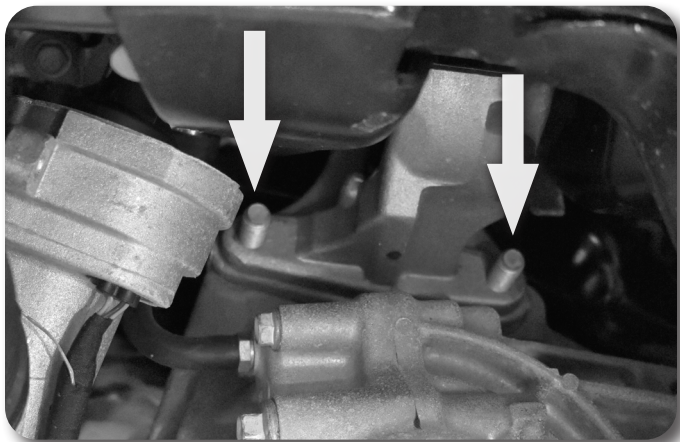

Figure 26

47. Remove three bolts on driver rear side and with the differential securely supported, lower the differential from the vehicle.

Step 46 Tip

If using a ratcheting wrench, make sure it is reversible as you may get into a position where it gets stuck on the rib of the differential.

» CROSSMEMBER MODIFICATION

48. The passenger's side rear lower control arm pocket must be trimmed to provide clearance for the differential and new crossmember. Measure inward from the inboard edge of the alignment cam slot $1\text{-}3/4"$ and mark. Repeat on the opposite side of the pocket. Make a continuous line connecting the two marks over the top edge of the pocket. Trim the pocket on the line with a sawzall or cut off wheel. Paint any exposed metal to prevent corrosion **Figure 27**.

Fig. 27 Note

Be careful not to cut oil filter when cutting the crossmember..

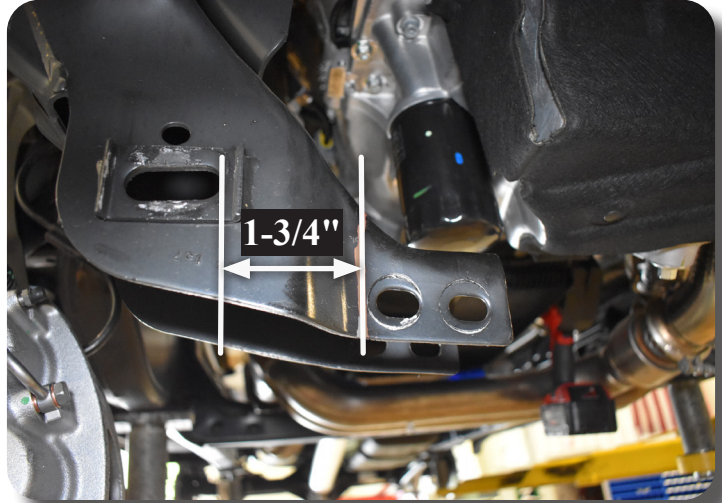

Figure 27

49. On the driver side rear cross member pocket, measure $1\text{-}1/4"$ downwards from center hole and trim horizontally for additional clearance for the new crossmember. **Figure 28** Repeat for passenger side. Clean up cut edges with a flapper sanding disc and coat with paint.

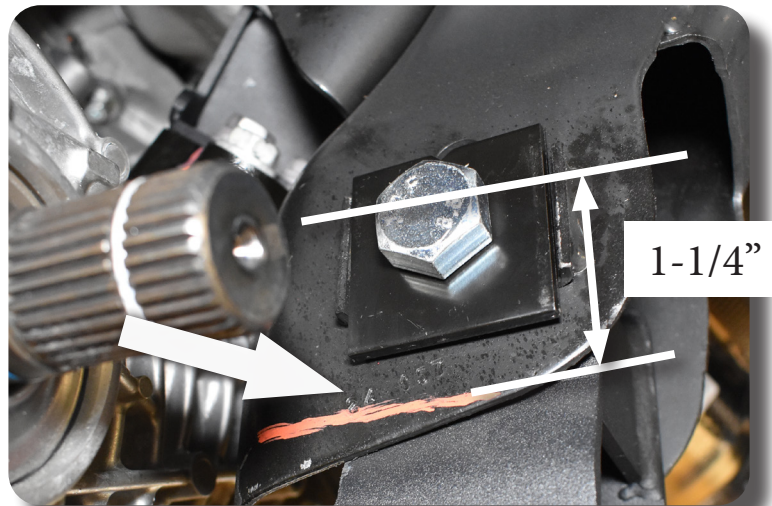

Figure 28

50. Loosely install the driver side front drop bracket to the block mount with the OE mounting bolts. Fig. 29

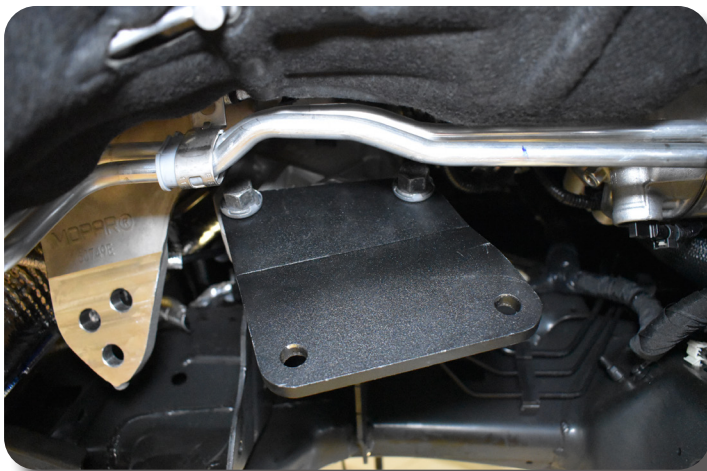

Figure 29

51. Loosely install the passenger side drop bracket to motor block mount with the OE mounting bolts. Fig. 30



Figure 30

» IF EQUIPPED WITH 3.0L ENGINE

Step 52 Tip

3.0L rear differential drop bracket has two gussets and mounting holes on the different mounting surface. 3.6L rear bracket has one gusset and slots on the differential mounting surface.

52. For 2025 trucks equipped with 3.0L I6 Hurricane engines, follow STEPS 52-56. Trucks with 3.6L V6 Pentastar engines, follow STEPS 57-60. Apply thread locker and loosely install rear drop bracket to the differential with the OE hardware. Three holes on the provided bracket mount to the cast spacer, three slots upwards to the engine mount. Figure 31



Figure 31

53. Using a jack and an assistant to aid in balancing, raise the differential up to the driver and passenger side drop brackets.
54. Fasten z-differential drop bracket to the engine mount with 1/2"-13 x 1-1/2" bolts, 1/2" SAE washers, and prevailing torque nuts. Do not torque at this time.
55. Attach the differential to the driver's side front bracket and passenger's side bracket with 12mm x 60mm bolts, nuts and washers. Figure 32

Step 54 Note

Hardware for the differential drop brackets is located in bolt pack 470.

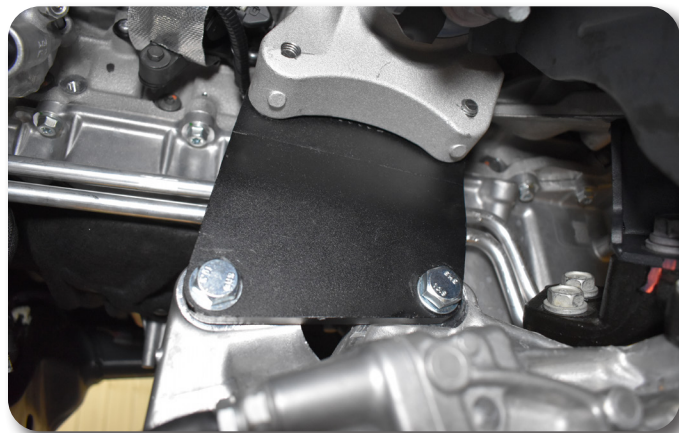

Figure 32

56. Torque differential mounting bolts: Start by tightening the driver side new brackets to the factory mounting positions (upper bolts), then working your way from driver side to passenger side tightening the brackets to the differential (lower bolts). Torque 1/2" hardware to 80 ft-lbs and the 12mm hardware to 70 ft-lbs.

» **IF EQUIPPED WITH 3.6L ENGINE**

57. For 2025 trucks equipped with 3.6L V6 Pentastar engines. Install the driver's side rear differential drop bracket to the OE mount location with three 1/2" x 1-1/2" bolts and 1/2" SAE washers. Figure 33 The bracket will have the gusset plate towards the front of the vehicle. Leave hardware loose.

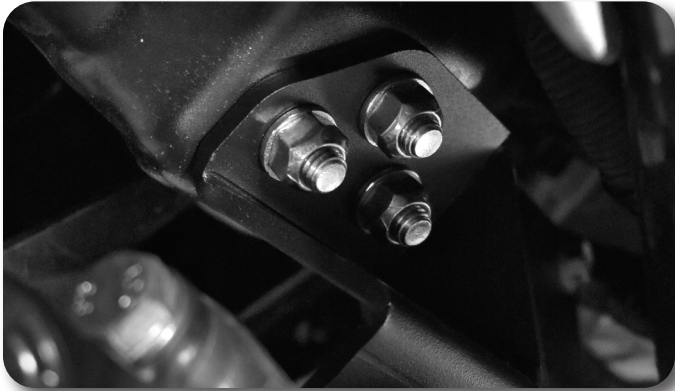

Figure 33

58. Using a jack and an assistant to aid in balancing, raise the differential up to the driver and passenger side drop brackets.
59. Attach the drivers side rear bracket to the differential with 12mm x 40mm bolts and washers BP #470. Attach the differential to the driver's side front bracket and passenger's side bracket with 12mm x 60mm bolts, nuts and washers. Leave all differential hardware loose. Figure 34

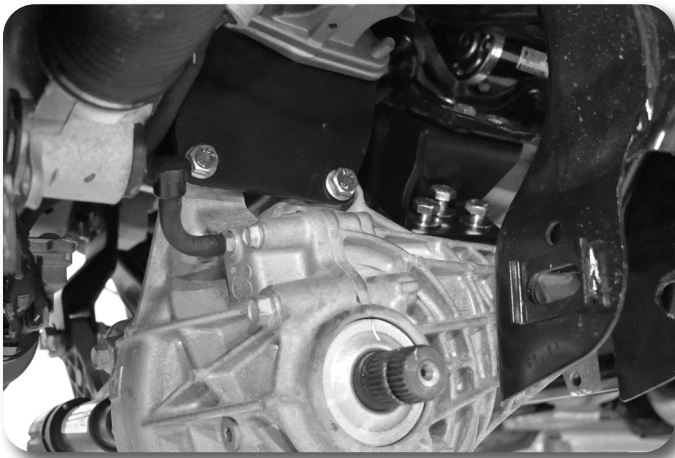

Figure 34

60. Torque differential mounting bolts: Start by tightening the driver side new brackets to the factory mounting positions (upper bolts), then working your way from driver side to passenger tightening the brackets to the differential (lower bolts). Torque 1/2" hardware to 80 ft-lbs and the 12mm hardware to 70 ft-lbs.
61. BOTH ENGINE PLATFORMS. Locate the Front Axle Disconnect (FAD) wiring harness. Remove from factory clips to give enough slack to reach the differential. Reattach to differential and tie up extra slack with provided zip ties.

Step 59 Note

Hardware for the differential drop brackets is located in bolt pack 470

Step 62 Note

The offset in the crossmember goes to the front, bolts run from front to rear.

62. Install the new front crossmember in the OE front lower control arm pockets and loosely fasten with the provided 18mm x 150mm bolts, nuts in conjunction with the provided rectangle cam slot washers. (8 pcs) Fig. 35 Do not torque mounting bolts at this time.



Figure 35

63. Provided cam washers allow for adjustability to compensate for frame variances. When installing cam washers determine what position fits best to your frame. Make sure whatever position the cam washer is in that the other side is opposite. For example if your frame is wide, you would offset your cam washers to the outside of the vehicle on either side. Fig. 36

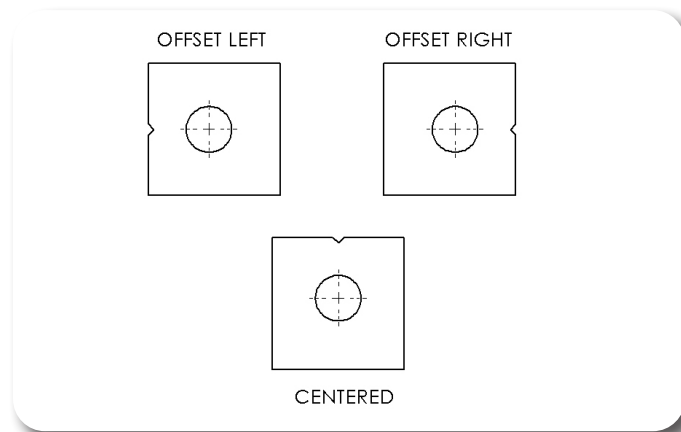

Figure 36

64. Install the new rear crossmember in the OE rear lower control arm pockets and loosely fasten with the provided 18mm x 150mm bolts, nuts in conjunction with the provided cam slot washers. Run the bolts from front to rear and leave loose at this time. Fig. 37

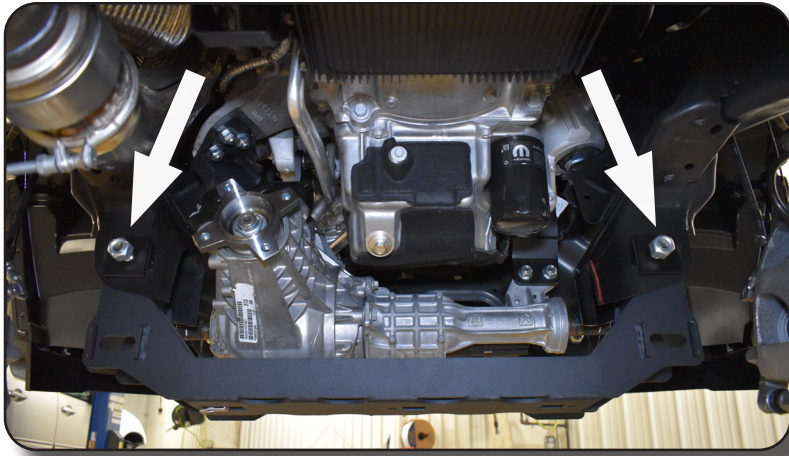

Figure 37

65. The kit includes a stainless Zone logo plate that can either be painted or installed as is using the provided rivets or screw/nuts.
66. Install the new differential skid plate to the front and rear crossmembers with four 1/2" x 1-1/4" bolts, 1/2" SAE washers and prevailing torque nuts. Hardware is from BP #470. Figure 38

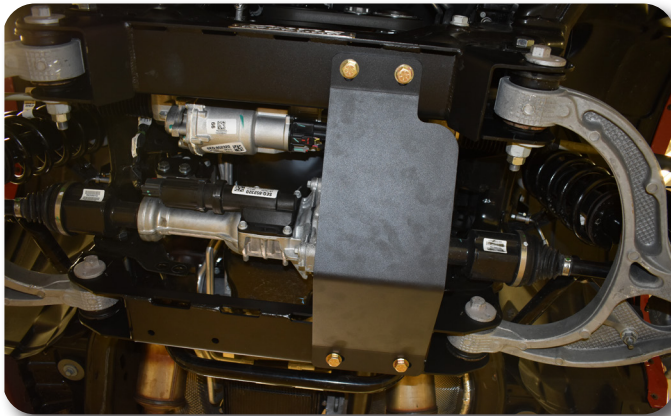

Figure 38

67. Install the lower control arms in the front and rear crossmembers. Attach the control arms to the crossmembers with the OE cam bolts, washers and nuts running from front to rear. Leave hardware loose. Fig. 39



Figure 39

68. With the lower control arms installed, torque the 18mm crossmember mounting bolts to 239 ft-lbs. Torque the 1/2" differential skid plate hardware to 80 ft-lbs.
69. Re-attach three transmission coolant line brackets. Torque to OE specification.
70. Install the provided drive shaft spacer on the differential input flange. Attach the front driveshaft to the differential by aligning the marks made earlier. Fasten the driveshaft and spacer to the differential flange with 12mm x 45mm bolts and 12mm washers BP #663. Use thread locker on the bolt threads and torque to 70 ft-lbs. Fig. 40



Figure 40

71. Check clearance of the transmission shift linkage splash guard to the drive shaft. Trim guard as necessary for driveshaft clearance Fig. 41

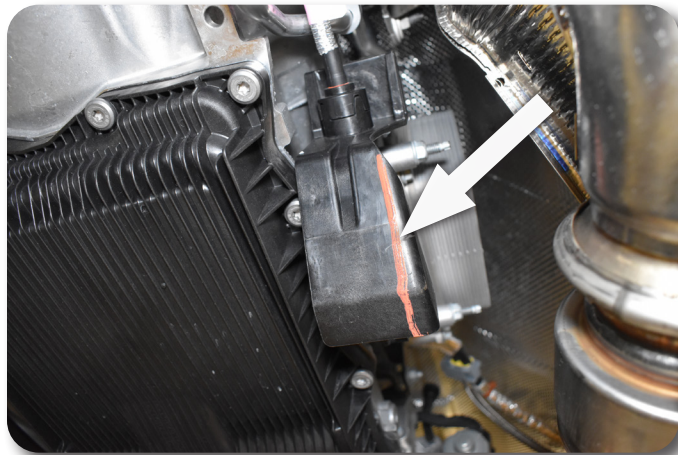

Figure 41

72. Verify Front Axle Disconnect (FAD) wiring harness slack to the front differential (from Step 62).
73. Re-install the Steering Rack to frame using the OE bolts, torque hardware to 118 + 90° ft-lbs. Reconnect the four wiring plugs. Fig. 42

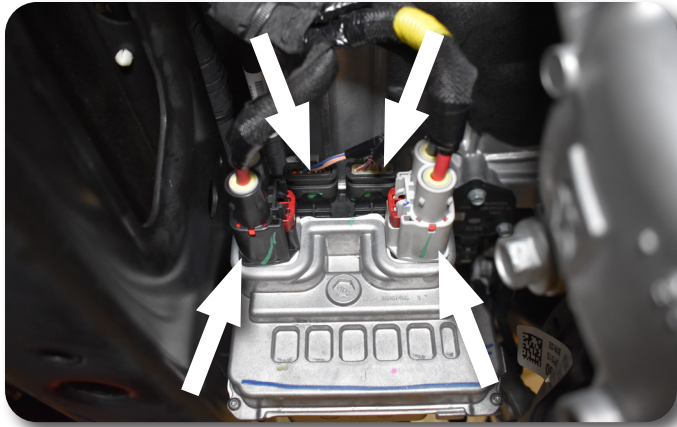

Figure 42

74. Re-attach the intermediate steering shaft to the steering gear. Torque pinch bolt to 41 ft-lbs.

» FOR 6" KITS, FOLLOW STEPS 75-78 TO INSTALL STRUT PRELOAD SPACER. 4" KITS, SKIP TO STEP 79.

75. Place indexing marks on the strut body, strut cap and upper coil seat **Figure 43, 44** for realignment of the components when the strut is reassembled.

OTE: If installing the 6" kit on a Rebel or truck with the "Off Road Group Package" the truck will sit about 1/2" front high with the preload spacer installed. If the preload spacer is not installed, the truck will sit with about 3/8" of rake.

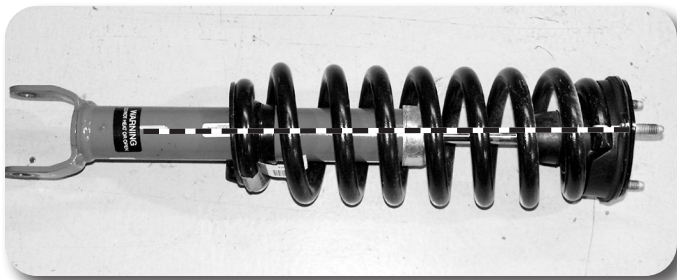

Figure 43



Figure 44

Step 76 Caution

Coil spring is under extreme pressure. Improper removal/installation of coil spring could result in serious injury or death. Use only a high-quality spring compressor and carefully read and follow the manufacturer's instructions.

76. Using an appropriate strut compressor, compress the coil spring and remove the upper strut nut **Figure 45**. Remove the strut, strut cap and upper coil seat from the coil spring.

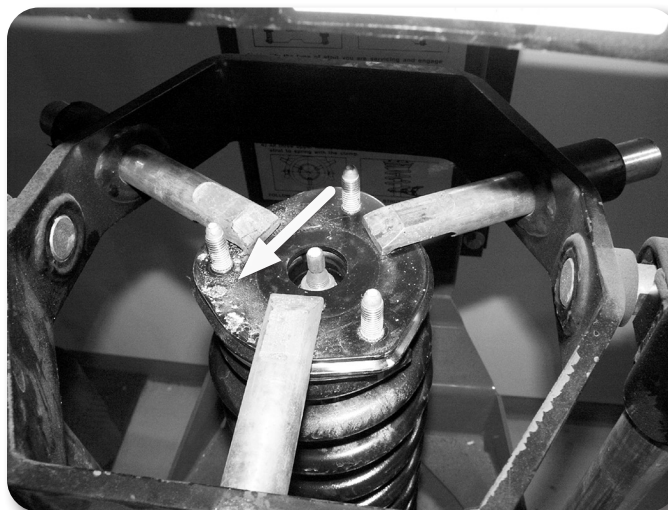

Figure 45

77. Place the provided preload spacer between the plastic coil seat and the rubber isolator **Figure 46**

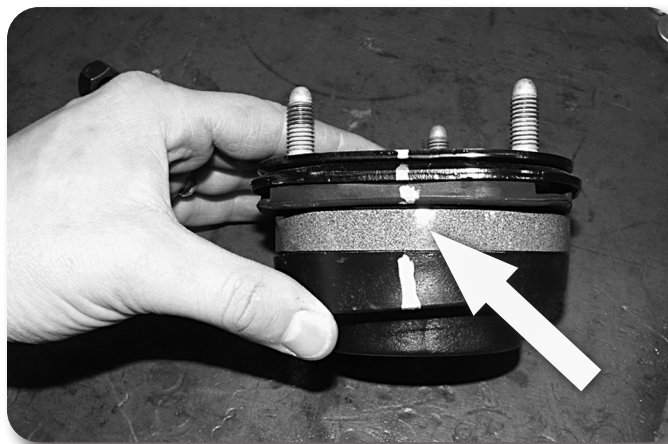

Figure 46

78. Reassemble the strut as it was taken apart by aligning the index marks made earlier. Fasten the assembly with the OE strut nut. Torque strut rod nut to 26 ft-lbs.

79. For 4" and 6" kits install the provided strut spacers on the struts with the OE strut mounting hardware. Torque nuts to 46 ft-lbs. Fig. 47

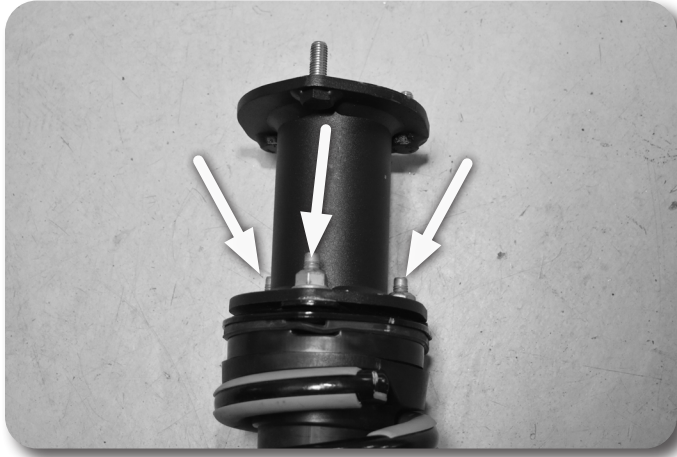

Figure 47

80. Loosely install the strut assemblies on the strut tower using the provided 10mm nuts and washers on the strut spacer studs. Finger tighten only. Fig. 48



Figure 48

81. Swing up the lower control arm and connect the lower strut with OE bolt and OE nut. Fig. 49 Torque the upper stud strut spacer nuts at the frame mount to 46

Step 80 Note

Strut spacer 10mm nuts and washers are located in bolt pack #481

ft-lbs. Finger tighten the strut to lower control arm hardware. Final torque will be completed with vehicle on the ground.



Figure 49

82. Install knuckle to the lower ball joint with OE nut and insert the CV axle into the wheel bearing. Ensure OE tabbed CV washer mounts between the CV housing and inboard face of the bearing assembly. Fig. 50 Torque lower ball joint nut to $38 + 195^\circ$ ft-lbs.



Figure 50

83. Connect knuckle to upper control arm ball joint using OE nut and provided 9/16" washer. Fig. 51 Torque to $26 + 180^\circ$ ft-lbs.

Step 83 Note

Provided washer for UCA ball joint located in B1648. For large bearing knuckle kits, washer is included in B1658.

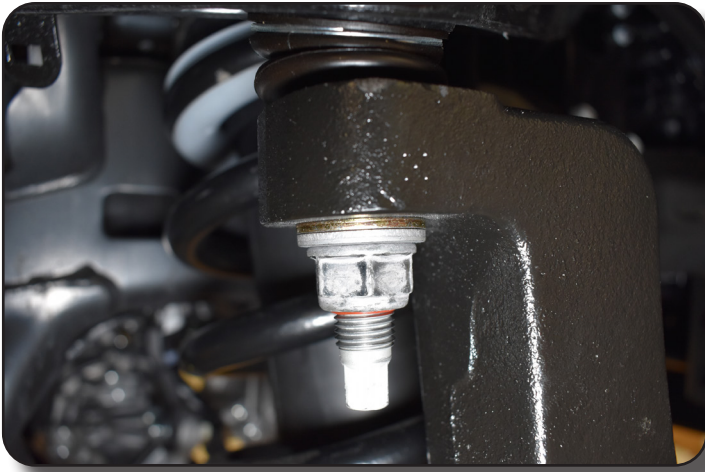

Figure 51

84. Install CV axle nut using 35mm socket. Fig. 52 Torque to 184 ft-lbs

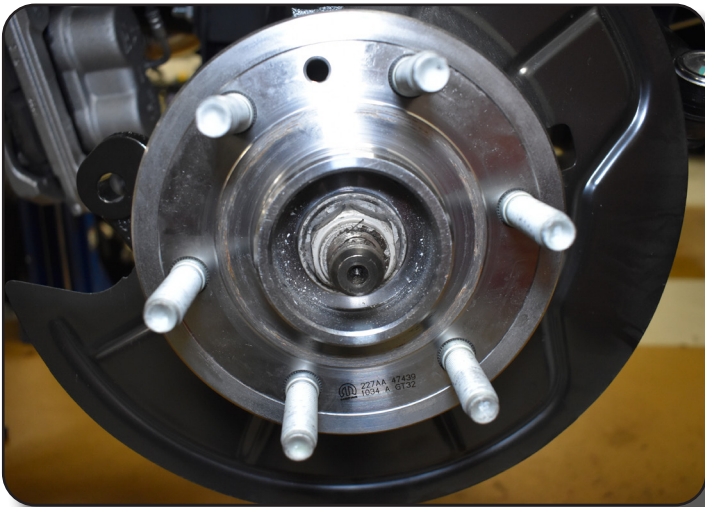

Figure 52

85. Install brake rotor replacing T30 bolt. Fig. 53



Figure 53

86. Remove ABS clip from the upper control arm for more slack to reach knuckle placement. Cycle steering to ensure adequate slack in ABS line. Fig. 54



Figure 54

87. **Large bearing knuckle kits skip to next step.** Install ABS sensor into knuckle and apply thread locker to bolt. Torque OE bolt to 62 in-lbs. Fig. 55

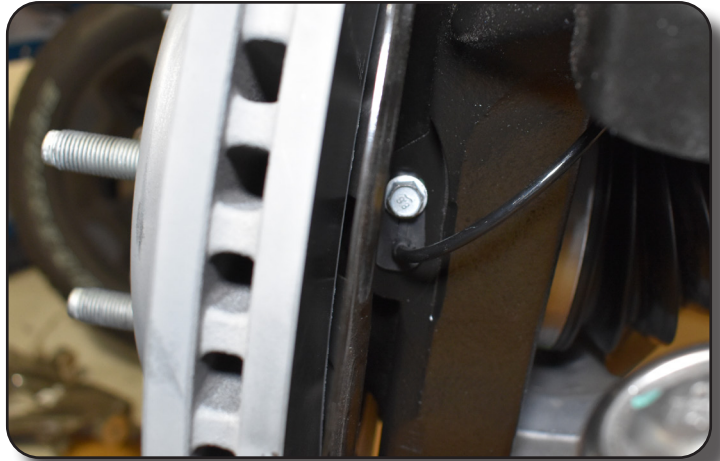

Figure 55

88. For large bearing knuckle kits, install the supplied ABS spacer between the mounting surface and the ABS sensor. Apply thread locker and torque OE bolt to 62 in-lbs Fig. 56

Step 88 Note

For large bearing knuckle kits, ABS spacers located in B1658.



Figure 56

89. Install brake calipers to knuckle with OE mounting bolts. Fig. 57 Apply high temperature rated thread locker and torque to 59 + 55° ft-lbs.

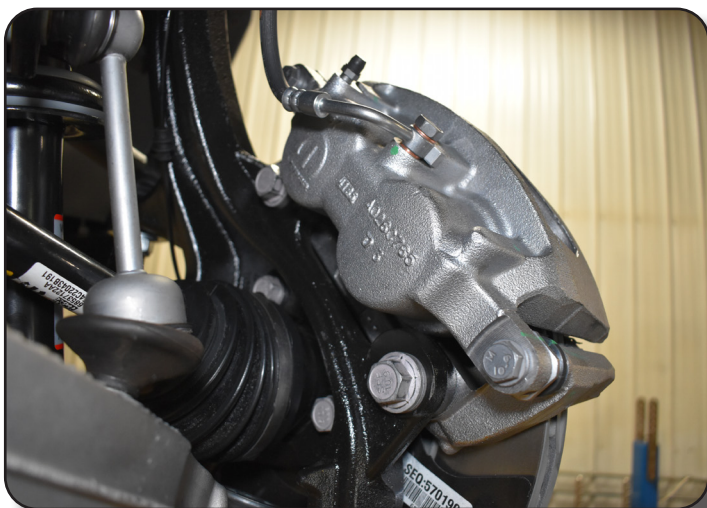

Figure 57

90. Loosen jam nut at the OE tie rod end and remove the OE tie rod end.
91. Install grease zerk into provided tie rod end and install new rod end onto tie rod.
Fig. 58



Figure 58

92. Connect tie rod end to knuckle using provided nut and washer. Fig. 59 Torque tie rod end nut to 55 ft-lbs. Once torqued, grease the tie rod end at the zerk fitting.

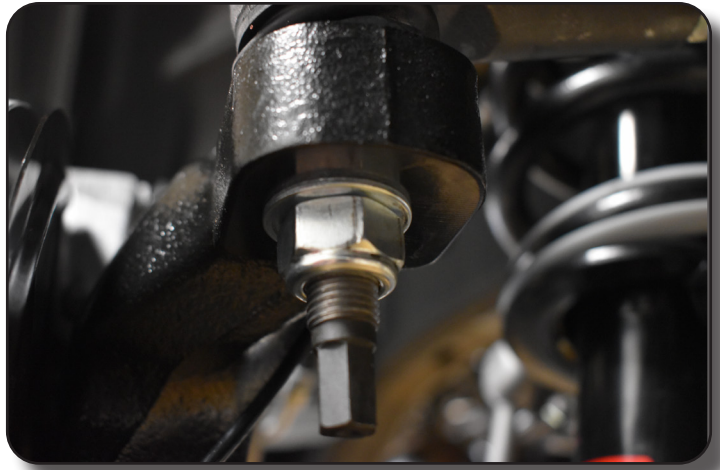

Figure 59

93. Repeat installation steps 81-92 on opposite hand side of vehicle.
94. Install sway bar drop brackets using the OE mounting bolts to the frame. Fig. 60
Torque bolts to 33 ft-lbs



Figure 60

95. Reconnect sway bar link to the lower control arm. Hand tighten the sway bar link nut at the lower control arm a couple turns but do not tighten. Fig. 61, 62 Final torque will be completed with the vehicle on the ground.



Figure 61

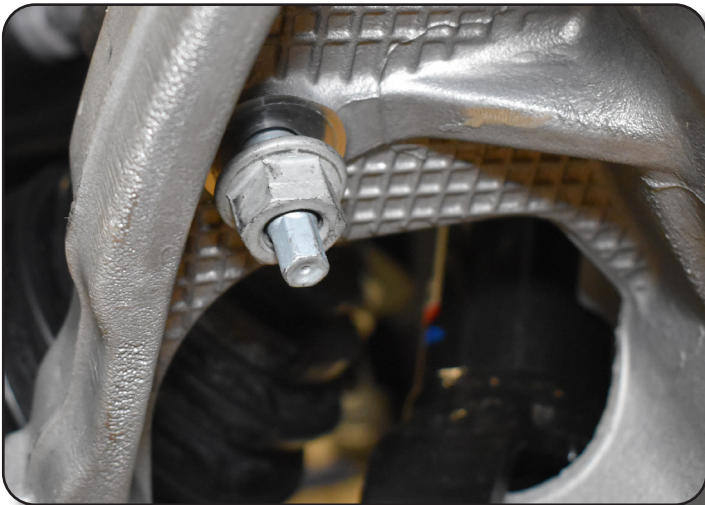

Figure 62

96. Connect sway bar to drop brackets using provided 3/8"-16 x 1-1/4" bolts washers and prevailing torque nuts. Fig. 63 Torque hardware to 33 ft-lbs



Figure 63

97. Reconnect the ABS wires at the frame.

98. Reinstall front wheels and lower vehicle to the ground. Torque wheels to factory specifications, see owner's manual. Aftermarket alloy rims will require more frequent attention. Check lug nuts for proper torque frequently.
99. Bounce the front to settle the suspension.
100. Torque lower control arms bolt hardware to 74 + 145° ft-lbs. Torque the strut-to-lower control arm bolt to 125 ft-lbs. Torque sway bar link to control arm nut to 81 ft-lbs.

» **OPTIONAL - BUMPER SPACER KIT INSTALL, SOLD SEPERATELY**

****** *Provides additional tire-to-fender clearance*

101. Remove the front lower inner fender liner.
102. Disconnect the bumper wire harness connectors on both driver and passenger sides. Fig. 64, 65



Figure 64

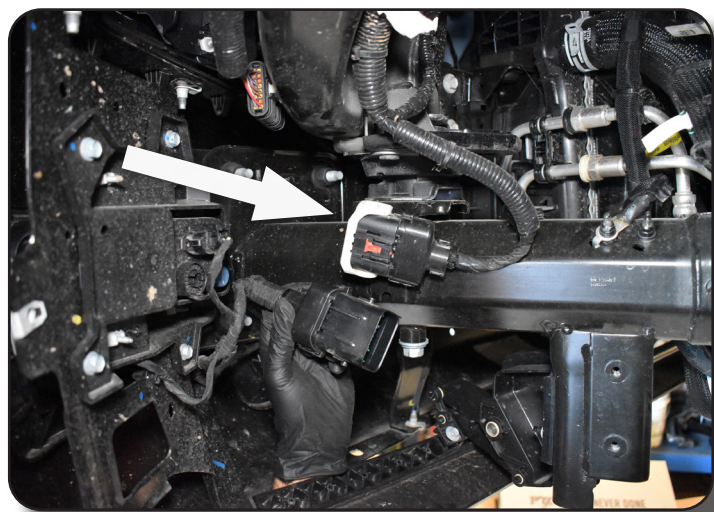

Figure 65

103. Disconnect the six nuts (three per side) mounting the bumper to the frame horns. With an assistant, remove bumper.

104. Remove the OE pushnut retainers using a pair of side cutters. The OE carriage bolts and pushnuts will not be reused. Fig. 66



Figure 66

105. Install new provided carriage bolts and pushnut retainers in the original bumper mounting locations. Fig. 67

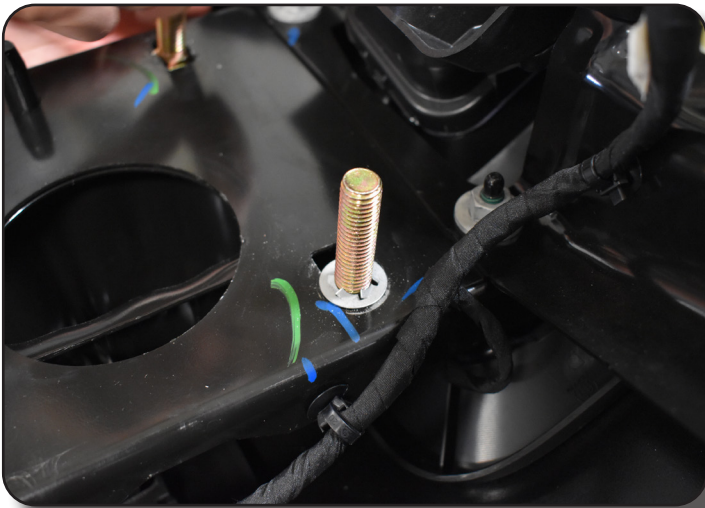

Figure 67

106. Remove lower accent trim attached to the bottom of the grill insert. It is held in place with four pushpins and will not be reinstalled. Fig. 68

Step 103 Note

Bumper Spacer hardware located in BP1087, spacers located in B1656.



Figure 68

107. Trim up to the bottom of the four push pin mounting holes, level, across the entire width of the grill support. It is recommended to use a reciprocating pneumatic buzz saw, cleaning up cut edge with a deburring tool. **Fig. 69**



Figure 69

108. Place provided spacers onto carriage bolts. With an assistant, loosely remount bumper to the vehicle using six provided 1/2" washers and six M12 prevailing torque nuts. Adjust bumper elevation to fender gap. Torque nuts to 49 ft-lbs.
109. Reconnect both driver and passenger side bumper wire harness connectors. Reinstall lower inner fender liner.

» REAR INSTALLATION

1. Park the vehicle on clean, flat, and level surface. Block the front wheels for safety.
2. Disconnect the rear trackbar from the axle, retain hardware.
3. Raise the rear of the vehicle and support the frame rails with jackstands.
4. Remove the wheels.
5. Support the axle with a hydraulic jack.
6. Remove the inner fender liner.
7. Remove the OE shocks. Retain the mounting hardware.

8. Disconnect brake line brackets from the outside of the frame rails. Separate the ABS wire retaining clips from the frame. **Figure 1 &2**

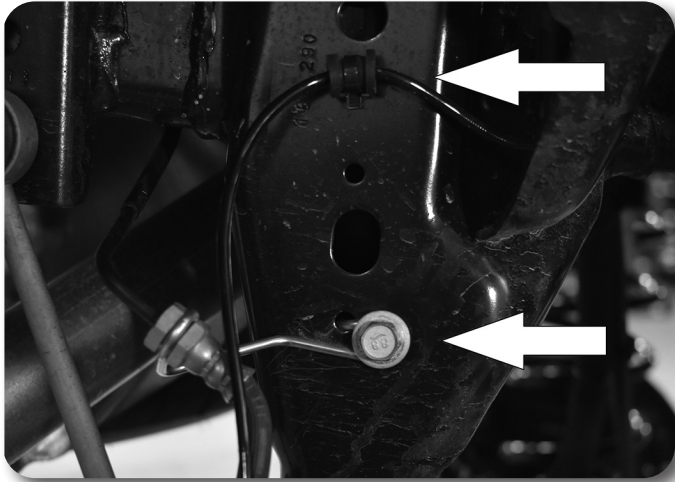

Figure 1

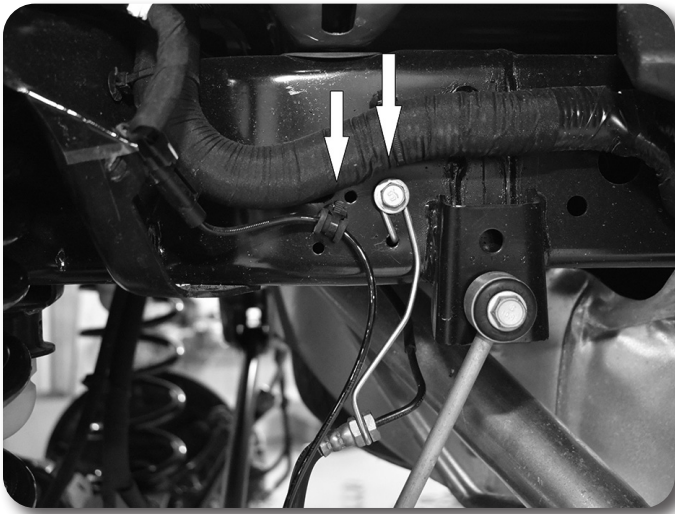

Figure 2

9. Remove rear sway bar links, retain hardware.
10. Lower the rear axle and remove the coils, retain the rubber isolators.
11. **Steps 11-18 are for models with factory fuel tank skid plates only, if your vehicle does not have a skid plate under the fuel tank, skip to step 19.** The factory fuel tank skid plate requires trimming to maintain clearance to the drive shaft and axle housing through articulation at a lifted height.

12. To remove the skid plate you must first support the weight of the skid plate with a jack or an assistant while you remove the mounting hardware as shown. Figure 3, 4, 5. Retain hardware.



Figure 3



Figure 4



Figure 5

13. Trim the inside edge of the skid plate closest to the drive shaft. Cut as shown **Figure 6** along the yellow lines. The first cut is a continuation of a factory edge pointed out with the arrow below then cut parallel to the factory edge to a distance of 22" from the furthest back edge of the skid plate. From that point cut towards the edge of the skid plate at an angle to meet with a point 33" from the rear edge of the skid plate.

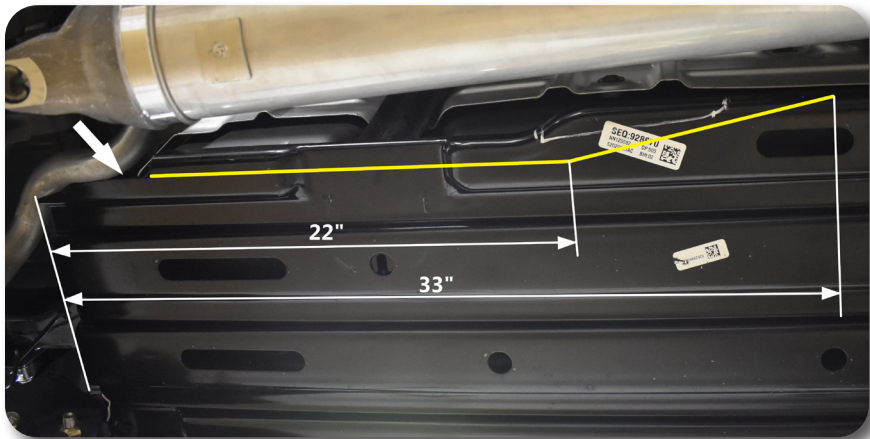

Figure 6

14. The second trim will be for clearance to the differential housing. On the rear inside corner of the skid plate, mark a point on the inside edge 3" from the back edge of the skid plate, and another point on the back edge 1- $\frac{3}{8}$ " from the inside edge of the skid plate. Cut a straight line connecting these two points to create the clearance as shown below **Figure 7** .

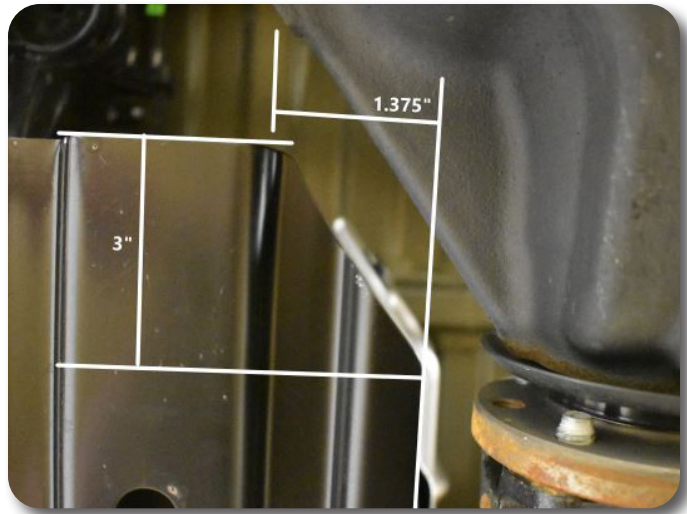

Figure 7

15. Completed driveshaft and axle clearance trimming shown below Figure 8.



Figure 8

16. Locate the rear outside corner of the skid plate. Notch this area of the skid plate 1/2" in from the rear edge and 3" in from the outer edge cutting around the mounting hole as shown Figure 9.



Figure 9

17. Once all trimming is complete paint the bare edges to prevent corrosion.
18. Install fuel tank skid plate using factory hardware, torque all the skid plate hardware to 15 ft-lbs.
19. Disconnect the upper control arm from the axle. Loosen the upper control arm bolt at the frame rail, but do not remove. **Figure 10** Retain hardware.



Figure 10

20. Place the upper control arm relocation bracket over the pocket. The bracket will offset towards the inside of the vehicle from the factory control arm mount. Use the 5/8"-11 x 4-1/2" bolt, lock nuts, flat washers, and 1" x 2-3/8" long sleeve 110 between bracket tabs at stock control arm mount location. Use the 3/8-16 x 1-1/4" bolts to attach the bracket to the top of the axle. Use 1" x 2-3/8" long sleeve between bracket tabs at stock mounting location. See **Figure 11** and 12.

NOTE: Due to some axle variances, it may be necessary to slot the factory holes on the top of the axle in order to install 3/8" hardware. To do so, hold the bracket in place and mark the center of the slots of the bracket onto the top axle mount. Use a die grinder to open up existing holes or drill new holes in the axle mount to 7/16".



Figure 11

Step 20 Note

Rear control arm bracket hardware is located in bolt pack 483

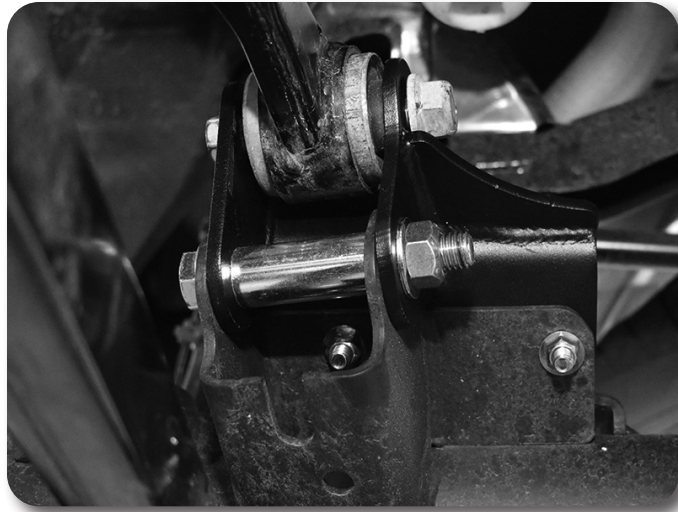

Figure 12

21. Install the upper arm with the OE bolt. Leave control arm hardware loose at this time. Tighten 3/8" hardware to 35 ft-lbs, and 5/8" hardware to 95 ft-lbs.
22. Slowly lower the axle. It may be necessary to unclip the hard brakeline mounts as well as the wiring harness clips on the rear diff. As you lower the axle ensure that all wiring/hoses have adequate slack and are not at risk of breaking.
23. Remove the two pieces of rubber coil wrap from the upper windings of the factory spring and transfer them to the new coil spring upper windings. Start the first piece on the second winding lined up with the end of the coil and start the second piece one winding down from where the first piece ends as shown in **Figure 13** to ensure there is no metal to metal contact when the spring compresses.



Figure 13

24. Install the new coil spring with the OE rubber isolator. Ensure the alignment pins on the OE isolator align with holes in the upper coil seat. **Figure 14**

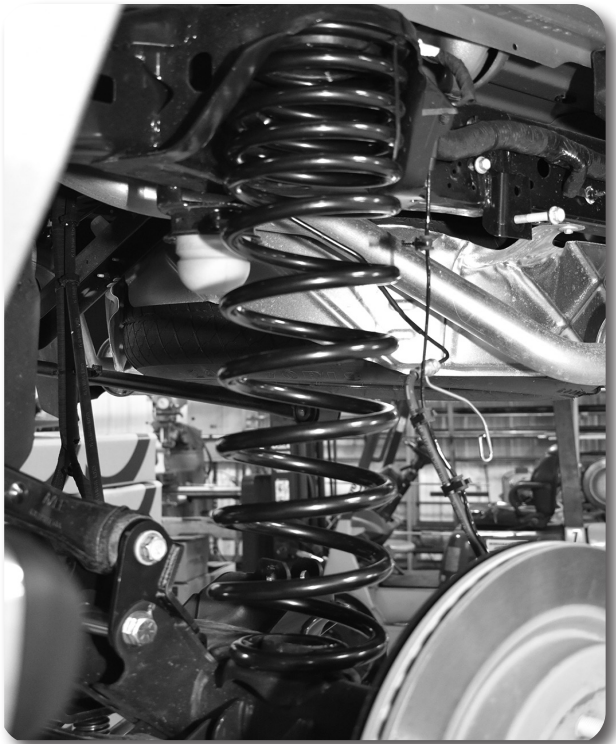

Figure 14

25. Install the new rear shocks. Tighten upper hardware so the bushing starts to swell. Tighten lower OE shock hardware to 107 ft-lbs.
26. Refer to the OE track bar bracket, Remove the ABS clip as shown in Figure 15 and drill hole so that it fits a 3/8" bolt,

Note: Due to OEM ABS clip hole variation, drilled hole may need to be filed out into a slot in order to align with bracket.

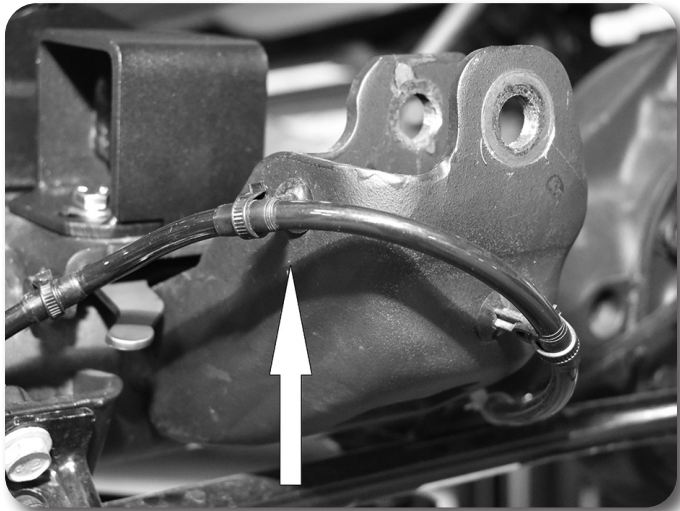

Figure 15

27. Install the track bar bracket back on the factory mount. Fasten with the provided 9/16" hardware through the original track bar hole. Place the provided crush sleeve in the factory bracket when installing the hardware. Attach bracket with 3/8" x 1-1/4" bolt, nuts and washers through the hole drilled in the previous step. Tighten 3/8" hardware to 35 ft-lbs and 9/16" to 95 ft-lbs. Figure 16

Step 27 Note

Hardware for the rear track bar bracket is located in bolt pack 483.



Figure 16

Step 28 Note

Hardware for the bump stop extensions is located in bolt pack 479.

28. Attach bump stop extensions to driver's and passenger's side with 5/16" x 7/8" bolts with prevailing torque nuts and washers. For the driver's side, slide the nut tab provided in the kit behind the OE track bar bracket hardware, under the bump stop plate. Figure 17 Both bump stop extensions are positioned towards the driver's side of the vehicle with the two holes in the bottom plate facing the passenger side. Tighten to 18 ft-lbs.

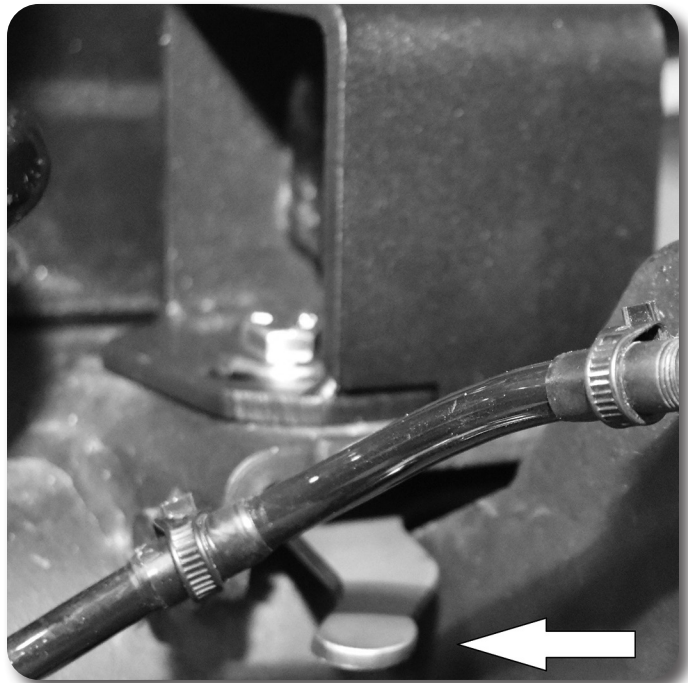

Figure 17

Step 30 Note

Hardware for the rear sway bar links is located in bolt pack 482.

29. Install hourglass bushings into sway bar links. Install one 12mm ID sleeve into one end of the sway bar and one 10mm ID sleeve into the other end.
30. Install sway bar links putting the 10mm ID sleeves to the top mount, fasten using OE hardware and 3/8" washers. Attach lower sway bar link to sway bar using 12mm bolt, prevailing torque nut and washers. Tighten to 55 ft-lbs. Figure 18 Sway bar links mount to the inside of the bracket, same as the factory sway bar links.



Figure 18

31. Install brakeline drop brackets on the side of the frame rail using OE hardware. Attach brakeline to bracket with 3/8"x1-1/4" bolt, washers, and nut. Tighten to 20 ft-lbs. **Figure 19** you will need to reform stock brake line wire mounts to allow adequate slack at full droop.

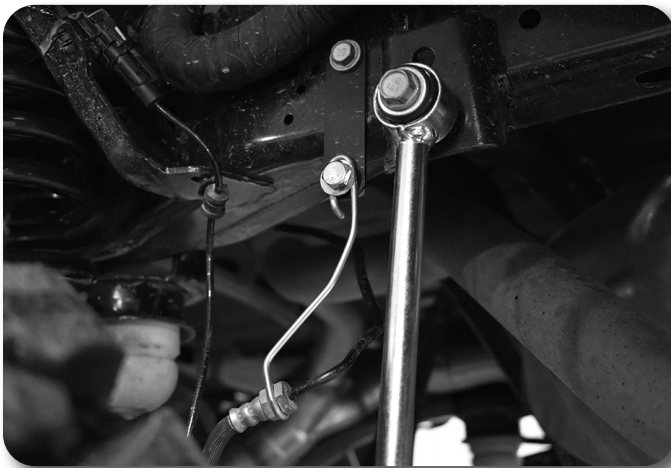

Figure 19

32. Reattach ABS wire to clips on brakeline.
33. Install wheels and lower vehicle to the ground.
34. Tighten upper control arm hardware to 111 + 110° ft-lbs.
35. Install rear trackbar into relocation bracket in the uppermost hole with OE bolt and nut. Tighten to 127 ft-lbs.

»» FINAL INSTALLATION STEPS

»» The brakes must be bled before driving the vehicle if the lines were disconnected in the installation. Follow the directions in the factory service manual. Also do a final check to ensure the brake lines will not contact the tire or other moving components.

36. A complete front end alignment is required.
37. Recheck all fasteners for proper torque. Check again after 500 miles and at regularly scheduled intervals.

Step 31 Note

Hardware for the rear brake line drop in bolt pack 483.

Post-Installation Warnings

1. Check all fasteners for proper torque. Check to ensure for adequate clearance between all rotating, mobile, fixed, and heated members. Verify clearance between exhaust and brake lines, fuel lines, fuel tank, floor boards and wiring harness. Check steering gear for clearance. Test and inspect brake system.
2. Perform steering sweep to ensure front brake hoses have adequate slack and do not contact any rotating, mobile or heated members. Inspect rear brake hoses at full extension for adequate slack. Failure to perform hose check/replacement may result in component failure. Longer replacement hoses, if needed can be purchased from a local parts supplier.
3. Perform head light check and adjustment.
4. Re-torque all fasteners after 100 miles. Always inspect fasteners and components during routine servicing.

Component	Torque (FT-LBS)
<i>Front Brake Line Factory Hardware</i>	15
<i>Front Brake Line 1/2" Bolt</i>	56
<i>Knuckle to Hub Mounting Bolts</i>	37 + 165°
<i>1/2" Diff Mounting Hardware</i>	80
<i>12mm Diff Mount Hardware</i>	70
<i>Skid Plate Bolts</i>	80
<i>18mm Crossmember Bolts</i>	239
<i>Driveshaft to Diff bolts</i>	70
<i>Steering Rack to Frame Bolts</i>	118 + 90°
<i>Intermediate Steering Shaft to Steering Gear</i>	41
<i>Strut Rod Nut</i>	26
<i>Strut Spacer Lower Nuts</i>	46
<i>Upper Ball Joint</i>	26 + 180°
<i>Lower Ball Joint</i>	38+195°
<i>CV Axle Nut</i>	184
<i>Strut Spacer Upper Nuts</i>	46
<i>Caliper Bracket Bolts</i>	59 + 55°
<i>Tie Rod To Knuckle Nut</i>	55
<i>OE Sway Bar Mounting Bolts</i>	33
<i>Sway Bar to Sway Bar Drop Bolts</i>	33
<i>Front Lower Control Arm Bolts</i>	74 + 145°
<i>Strut to Lower Control Arm Bolts</i>	125
<i>Rear Control Arm Bracket 3/8" Hardware</i>	35
<i>Front Sway Bar Link to Lower Control Arm</i>	81
<i>Rear Control Arm Bracket 5/8" Hardware</i>	95
<i>Rear Lower Shock Bolts</i>	107
<i>Rear Trackbar Bracket 3/8" Hardware</i>	35
<i>Rear Trackbar Bracket 9/16 Hardware</i>	95
<i>Rear Bump Stop Hardware</i>	18
<i>Rear Sway Bar Link 12mm Hardware</i>	55
<i>Rear Upper Control Arm Hardware</i>	111 + 110°
<i>Rear Track Bar to Bracket</i>	127