



INSTRUCTIONS—INSTRUCCIONES—CONSIGNES

APPLICATION: 08-10 FORD F 250/350/450
APP PART # 57-2360, 57-2365
HDX GRILLE GUARD

AUTOMOTIVE PRODUCTS, INC.

ITEM	QUANTITY	DESCRIPTION	TOOLS NEEDED
1	1	GRILLE GUARD	18MM SOCKET
2,3	2	MOUNTING BRACKETS (2) DRIVERS SIDE, (3) PASSENGER SIDE	18MM WRENCH
4	2	M12 HEX HEAD BOLTS	RATCHET
5	2	M12 STUD PLATES	TORQUE WRENCH
6	6	M12 FLAT WASHERS	
7	4	M12 LOCK WASHERS	
8	4	M12 HEX NUTS	
9	4	M12 HEX HEAD BOLTS (BLACK STAINLESS)	
10	8	M12 FLAT WASHERS (BLACK STAINLESS)	
11	4	M12 LOCK WASHERS (BLACK STAINLESS)	
12	4	M12 HEX NUTS (BLACK STAINLESS)	
13	2	PLASTIC RETAINERS	

1. Remove contents from box, verify all parts listed are present and free from danger. Carefully read and understand all instructions before attempting installation. Anti seize lubricant must be used on all stainless steel fasteners to prevent from galling.
2. Starting underneath the front of the vehicle, on the outside of the drivers side frame locate the factory slot and hole in the frame. Insert (1) M12 stud plate into the slot in the frame and thread (1) plastic retainer onto the stud plate to keep it from falling into the frame (fig 1). Take the drivers side mounting bracket and attach it to the previously installed stud plate using (1) M12 flat washer, (1) M12 lock washer, and (1) M12 hex nut, attach the front mounting point using (1) M12 hex head bolt, (2) M12 flat washers, (1) M12 lock washer, and (1) M12 hex nut (fig 2). Do not fully tighten at this time. Repeat this step for passenger side
3. Move to the front of the bumper and remove the (4) factory bumper bolts Note: The (4) factory bumper bolts and the (2) factory nut plates will be used to attach the grille guard. (fig 3)
4. With assistance, take the grille guard and align it with the mounting brackets and the factory bumper bolt locations. Attach the grille guard to the lower brackets using (4) M12 hex head bolts (stainless), (8) M12 flat washers (stainless), (4) M12 lock washers (stainless, and (4) M12 hex nuts (stainless) (fig 4 and 5). Attach the upper grille guard mounting tabs using the (4) factory bumper bolts, install them as they were removed (fig 5 and 6). Do not fully tighten at this time.
5. Align and adjust grille guard as needed and then fully tighten all hardware. Torque al M12 hardware to 55 ft lbs, and factory hardware to factory specifications.

CARE INSTRUCTIONS

- REGULAR WAXING IS RECOMMENDED. DO NOT USE ANY TYPE OF POLISH OR WAX THAT MAY CONTAIN ABRASIVES
- STAINLESS STEEL PRODUCTS CAN BE CLEANED WITH MILD SOAP AND WATER. STAINLESS STEEL POLISH SHOULD BE USED TO POLISH SMALL SCRATCHES.
- GLOSS BLACK FINISHES SHOULD BE CLEANED WITH MILD SOAP AND WATER



Westing Automotive Products, Inc.
5200 N. Irwindale Ave. Suite 220
Irwindale, Ca. 91706

Thank You for choosing Westin products
For Additional installation assistance please call
Customer service (800) 793-7846
www.westingautomotive.com

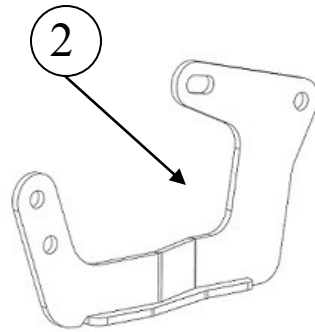
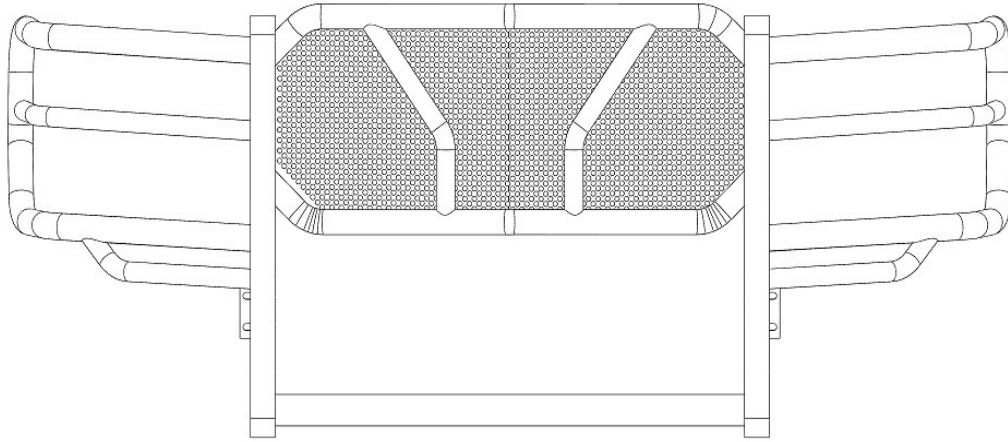

Passenger side shown Bolt plate installed and front mounting point shown

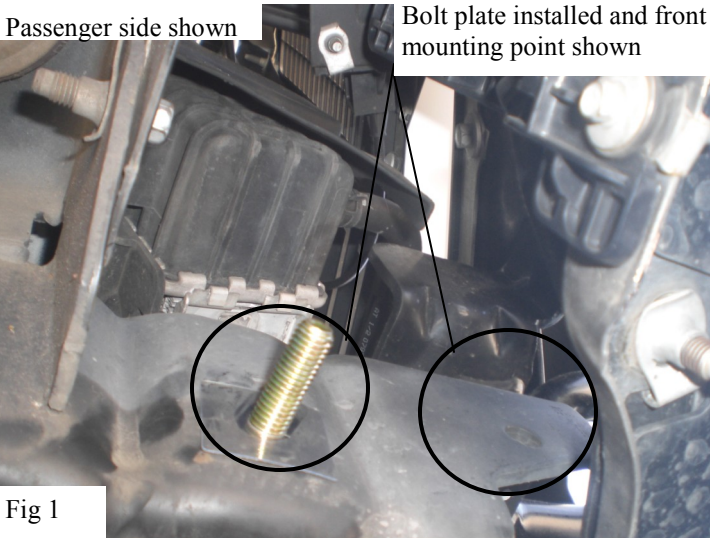

Fig 1

Drivers side shown

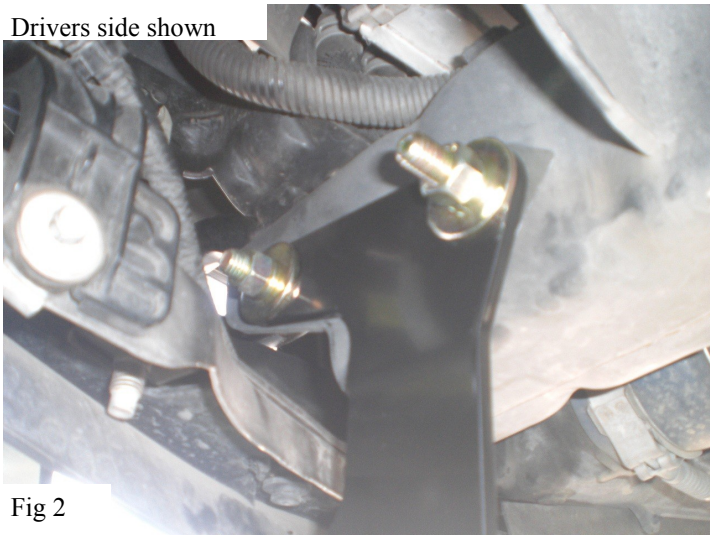

Fig 2



Fig 3



Fig 4



Fig 5



Fig 6

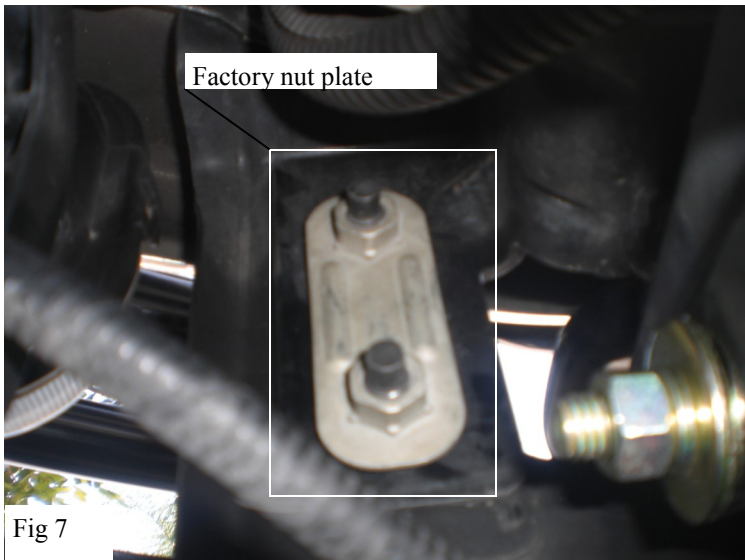

Fig 7



Installation complete

Westin.
SIGNATURE OF QUALITY

Westing Automotive Products, Inc.
5200 N. Irwindale Ave. Suite 220
Irwindale, Ca. 91706

7/18/2011 P.N.: 75-0021RevB w11-0031

Thank You for choosing Westin products
For Additional installation assistance please call
Customer service (800) 793-7846
www.westinautomotive.com