

# INSTALLATION INSTRUCTIONS

PART NO:HD18-JP-K12814

## PARTS LIST:

No.	Part Description	QTY	No.	Part Description	QTY
<b>A</b>	Main Body 1	1	<b>G</b>	M10 Nuts (SUS304)	4
<b>B</b>	Main Body 2	1	<b>H</b>	Rivet Nut	6
<b>C</b>	Main Body 3	1	<b>I</b>	M10X45 (Teeth long25)	1
<b>D</b>	M10×30 Bolts (SUS304)	10	<b>J</b>	M10 Flat Washers	2
<b>E</b>	M10 Lock Washers (SUS304)	10	<b>K</b>	M10 Chrysanthemum flat Washer	1
<b>F</b>	M10 Flat Washer (SUS304)	14	<b>L</b>	M12 Nuts	1

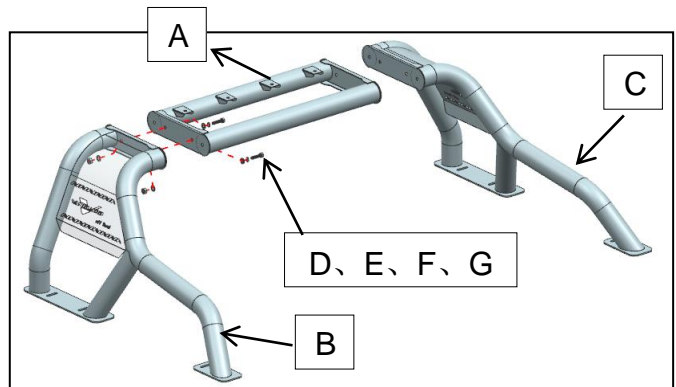
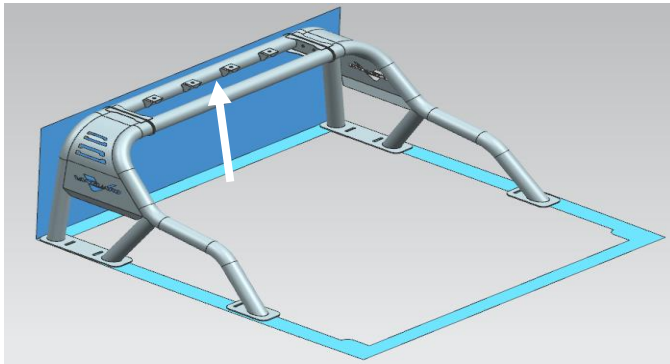

**H, I, J, K, L**

Drill  $\varnothing$  13.5 holes through top side of bed rails.  
 Apply automotive primer to any exposed metal.  
 Hand tighten Rivet nut, Item M10 Iahm to Rivet Nut Install Tool, Item M10 hex bolts.  
 Insert Rivet Nut into  $\varnothing$  13.5 hole.  
 Hold spacer with wrench.  
 Tighten bolt with wrench or socket and ratchet, this will compress the rivet nut.  
 Once tight, unscrew the bolt and Rivet Nut will be installed.

**D, E, F**