

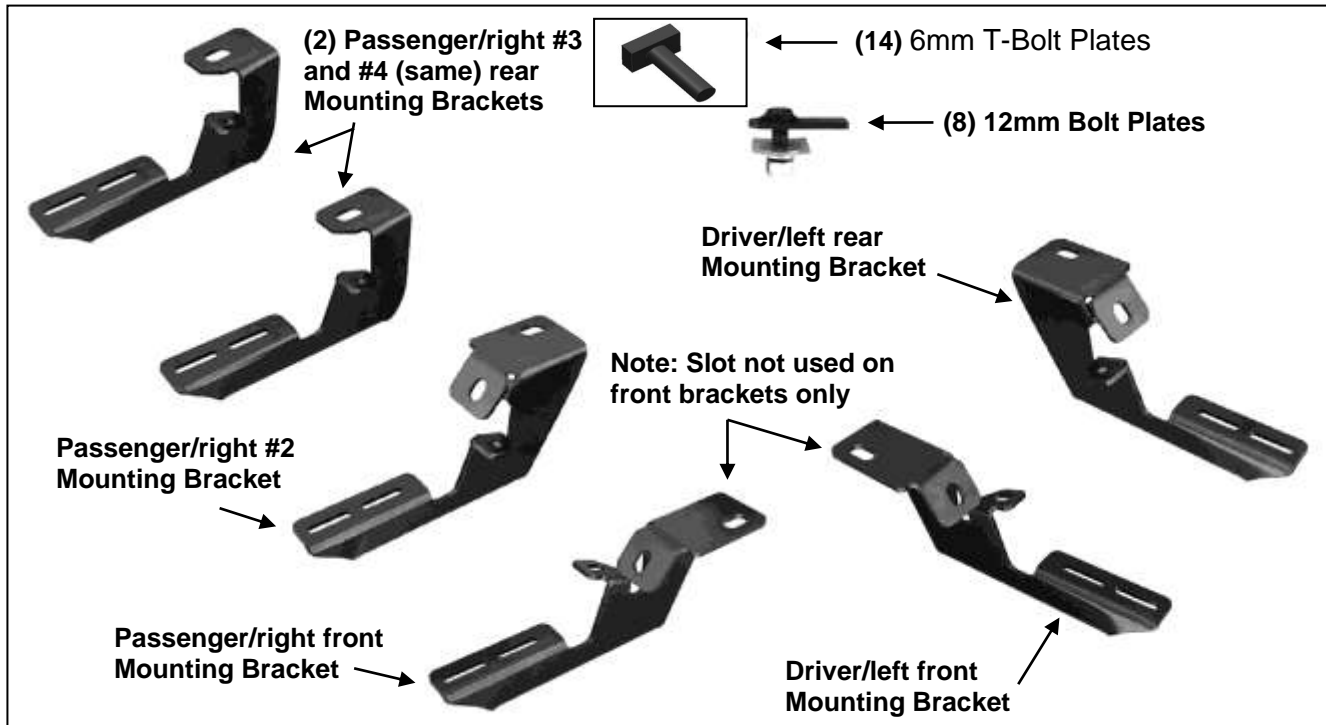

INSTALLATION INSTRUCTIONS
TRANSPORTER RUNNING BOARD BRACKET FOR 03-20 CHEVY
EXPRESS 1500/2500/3500 VAN (FULL SIZE)/ 03-20 GMC
SAVANA1500/2500/3500
PART # TR-G13596

PARTS LIST:

1	Driver Side- 37" Rattler Running Board	8	12mm Hex Nuts
1	Passenger Side- 96" Rattler Running Board	8	12mm Plastic Retainers
1	Driver Side Front Mounting Bracket	6	8mm x 30mm Hex Bolts
1	Driver Side Rear Mounting Bracket	12	8mm x 24mm OD x 2mm Flat Washers
1	Passenger Side Front Mounting Bracket	6	8mm Nylon Lock Nuts
1	Passenger Side Center Mounting Bracket	14	6mm T-Bolt Plates
2	Passenger Side Rear (#3 & #4) Mounting Brackets	14	6mm x 22mm OD x 2mm Flat Washers
8	12mm Bolt Plates	14	6mm Lock Washers
8	12mm x 32mm OD x 3mm Flat Washers	14	6mm Hex Nuts
8	12mm Lock Washers		



PROCEDURE:

REMOVE CONTENTS FROM BOX. VERIFY ALL PARTS ARE PRESENT. READ INSTRUCTIONS CAREFULLY BEFORE STARTING INSTALLATION. DRILLING IS REQUIRED.

1. Start the installation under the driver side of the vehicle. Locate and remove the rubber plug closest to the front tire opening, **(Figure 1)**. Select (1) 12mm Bolt Plate and (1) Plastic Retainer Washer, **(Figure 2)**. Partially thread the Plastic Washer onto the Bolt Plate. Insert the Bolt Plate into the opening and thread the Plastic Washer down tight, **(Figures 3 & 21)**. **NOTE:** The Plastic Washer is designed to help hold the Bolt Plate in place during Bracket installation but is not required for installation.
2. Select the driver side front Mounting Bracket, **(Figure 4)**. Attach the Bracket to the Bolt Plate with (1) 12mm Flat Washer, (1) 12mm Lock Washer and (1) 12mm Hex Nut, **(Figure 5)**. Hold the Bracket up tight against the bottom of the body and snug but do not fully tighten the hardware at this time.
3. Move along the bottom of the body to the rear bracket location, **(Figure 1)**. Locate and remove the (2) rubber plugs. Insert (1) 12mm Bolt Plate into each opening. Repeat **Steps 1 & 2** to attach the driver side rear Bracket to the (2) Bolt Plates, **(Figures 6 & 7)**. Do not fully tighten hardware at this time.
4. Select the short driver/left Running Board. Place the Running Board on top of the Brackets. Locate the channels in the bottom of the Running Board. Select (4) 6mm T-Bolt Plates, **(Figure 8)**. Insert the Bolt Plates into the channels in the bottom of the Running Board closest to the Brackets, **(Figure 9)**. Lift the Running Board up and guide the studs down through the Brackets.

5. Attach the Running Board to the Brackets with (4) 6mm Flat Washers, (4) 6mm Lock Washers and (4) 6mm Hex Nuts, **(Figures 10 & 11)**. **NOTE:** The Running Board is designed to fit close to the vehicle. It may be necessary to loosen the Bracket hardware and tilt the Brackets downward to insert the Running Board between the Brackets and the body. Do not tighten hardware at this time.
6. Level and adjust the Running Board forward or backward as desired. Push the Mounting Brackets up tight against the bottom of the body and fully tighten all hardware. Use the mounting tab on each Bracket for a guide, mark the location and drill a 5/16" hole through the pinch weld on both Brackets, **(Figure 11)**. **VERY IMPORTANT:** Do not drill too close to the edge of the pinch weld, adjust Bracket position as required before drilling through pinch weld. **NOTE:** It may be necessary to remove Running Board and Brackets to drill the required holes through the pinch weld. Repeat **Steps 2—5** to reinstall Running Board.

IMPORTANT! Any cutting or drilling tool may break or shatter. Government regulations require safety glasses & equipment at all times when cutting or drilling.

7. Once both holes have been drilled through the pinch weld, attach the mounting tabs on the (2) Brackets to the pinch weld with (2) 8mm Hex Bolts, (4) 8mm Flat Washers and (2) 8mm Nylon Lock Nuts, **(Figures 12 & 13)**. Fully tighten hardware at this time.
8. Move to the passenger side of the vehicle. Locate the rubber plug closest to the front tire opening, **(Figure 14)**. Repeat **Steps 1 & 2** to install the passenger side Front Bracket, **(Figures 15 & 16)**.
9. Continue along the body to the (2) rubber plugs identifying the 2nd mounting location, **(Figure 14)**. Repeat **Steps 1—3** to install the passenger side #2 Bracket, **(Figures 17 & 18)**.
10. Move along the body to the #3 bracket location below the side door, **(Figure 19)**. Locate and remove the rubber plug next to the pinch weld. Repeat **Step 8** to attach the #3 passenger side Bracket to the 12mm Bolt Plate in the #3 location, **(Figures 20 & 21)**.
11. Move to the last location along the passenger side in front of the rear tire. Repeat **Step 10** to attach the rear Bracket in the #4 location, **(Figures 22 & 26)**. **NOTE:** The #3 and #4 passenger side Brackets are identical. All other Mounting Brackets are unique and must be installed in the specified locations.
12. Next, select the long passenger side Running Board. Repeat **Steps 4—7** to drill the pinch weld for the Brackets and to install the passenger side Running Board, **(Figures 23—26)**.
13. Do periodic inspections to the installation to make sure that all hardware is secure and tight.

To protect your investment, wax this product after installing. Regular waxing is recommended to add a protective layer over the finish. Do not use any type of polish or wax that may contain abrasives that could damage the finish. Aluminum polish may be used to polish small scratches and scuffs on the finish. Mild soap may be used also to clean the Running Boards.

Driver/Left Side Installation Pictured

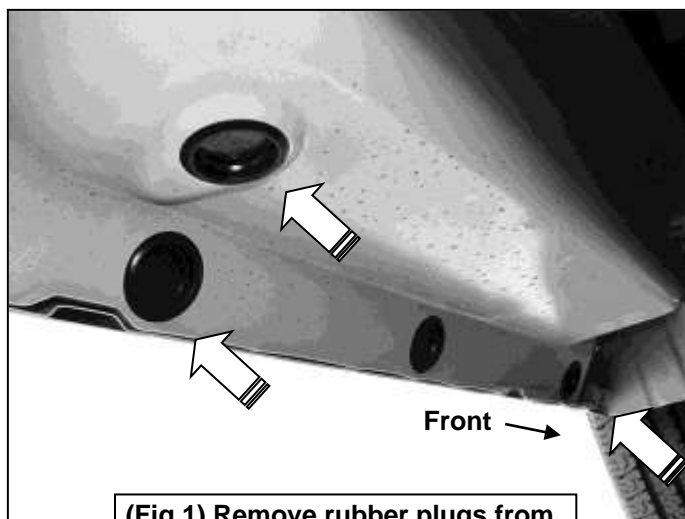

(Fig 1) Remove rubber plugs from (3) driver side mounting locations



(Fig 2) 12mm Bolt Plate w/plastic retainer

Driver/Left side installation pictured

12mm Bolt Plate w/plastic retainer

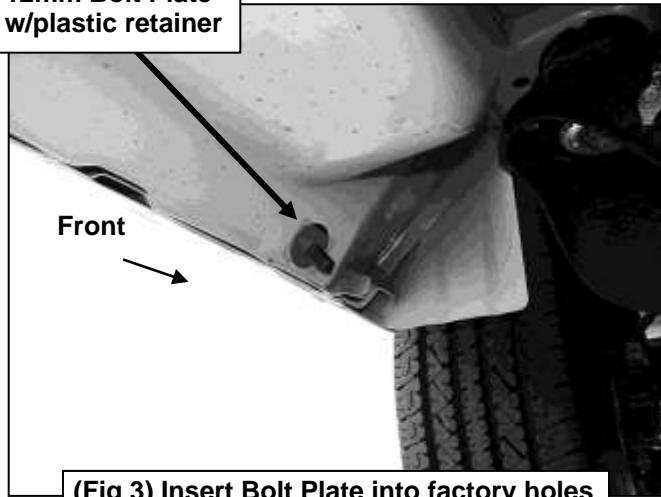

(Fig 3) Insert Bolt Plate into factory holes

Top mounting slot not used on front brackets only

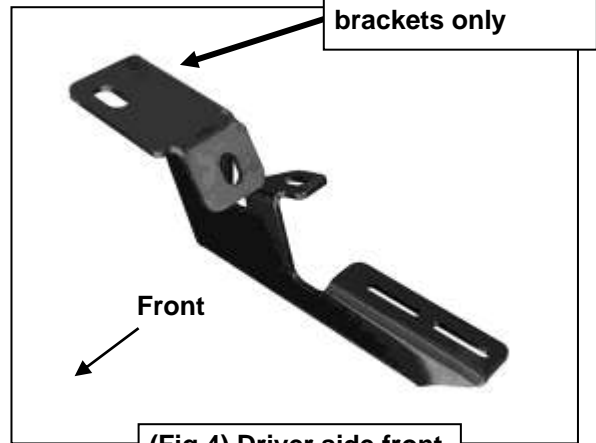

(Fig 4) Driver side front Mounting Bracket

Mounting slot not used on front brackets only

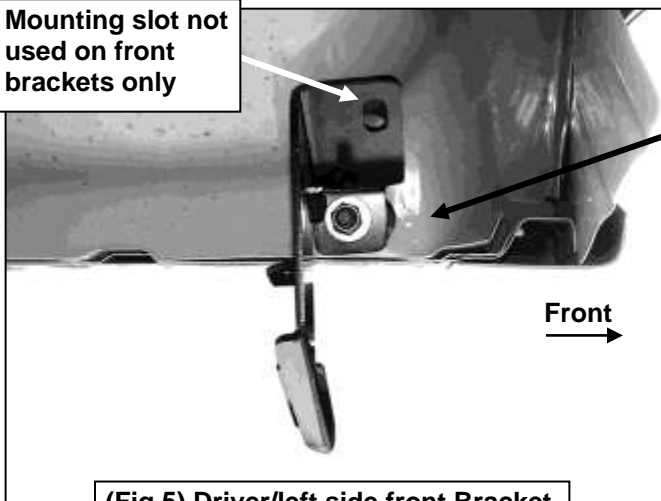

(Fig 5) Driver/left side front Bracket

12mm Flat Washer
12mm Lock Washer
12mm Hex Nut

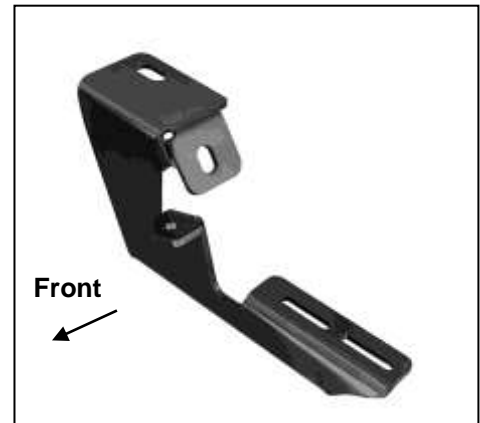

(Fig 6) Driver/left rear Mounting Bracket



(Fig 7) Driver/left rear Mounting Bracket installed

(2) 12mm Flat Washers
(2) 12mm Lock Washers
(2) 12mm Hex Nuts

Driver/Left side installation pictured

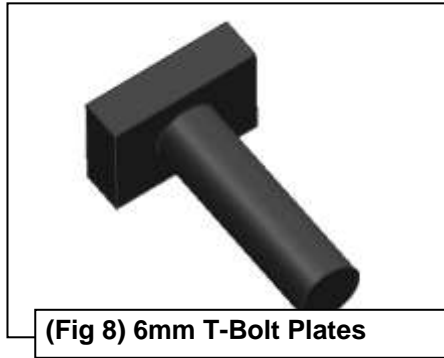

- (2) 6mm Flat Washer
- (2) 6mm Lock Washers
- (2) 6mm Hex Nuts

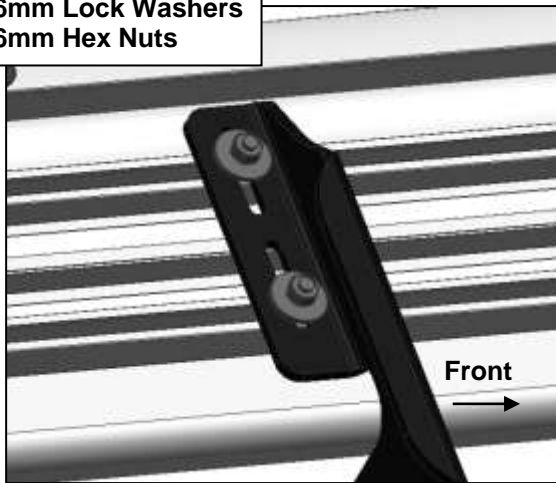

(Fig 10) Attach Running Board to Brackets

- 8mm Hex Bolt
- 8mm Lock Washer
- 8mm Flat Washer

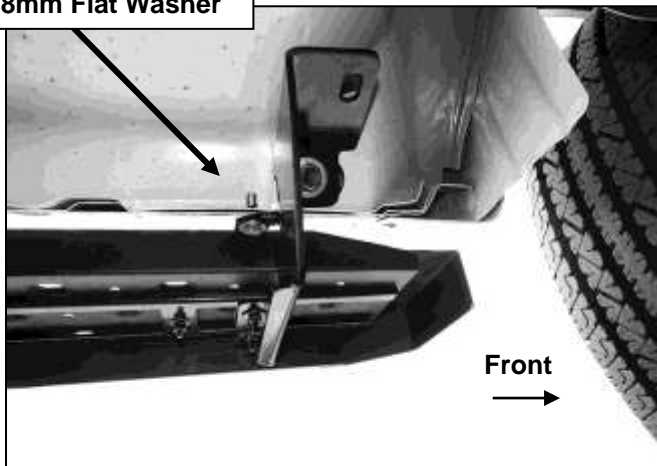

(Fig 12) Attach Driver side front Bracket to pinch weld

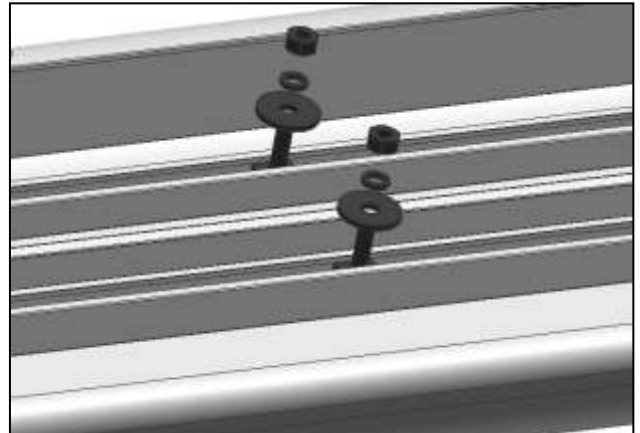

(Fig 9) Insert T-Bolt Plates into channels

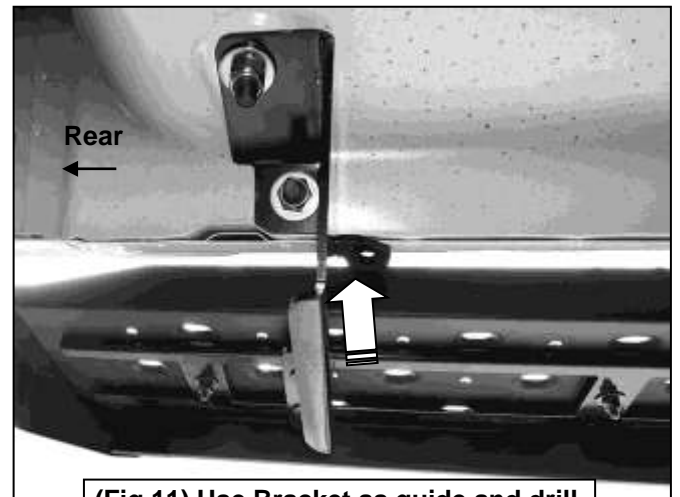

(Fig 11) Use Bracket as guide and drill 5/16" hole through pinch weld. Do not drill too close to edge of pinch weld (driver side rear Bracket pictured)

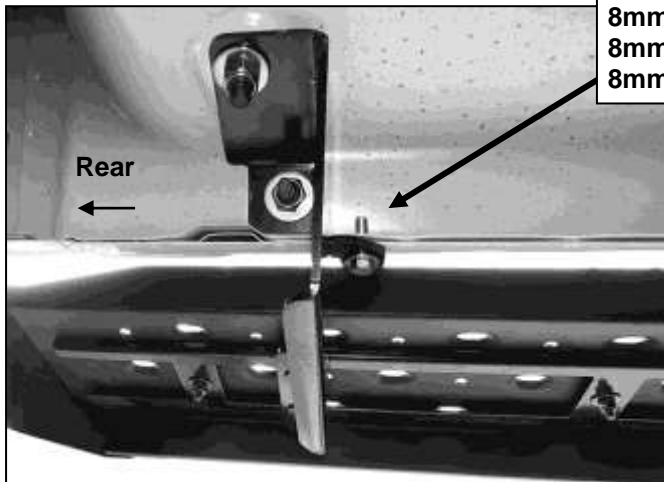

8mm Hex Bolt
8mm Lock Washer
8mm Flat Washer

(Fig 13) Attach Driver side rear Bracket to pinch weld

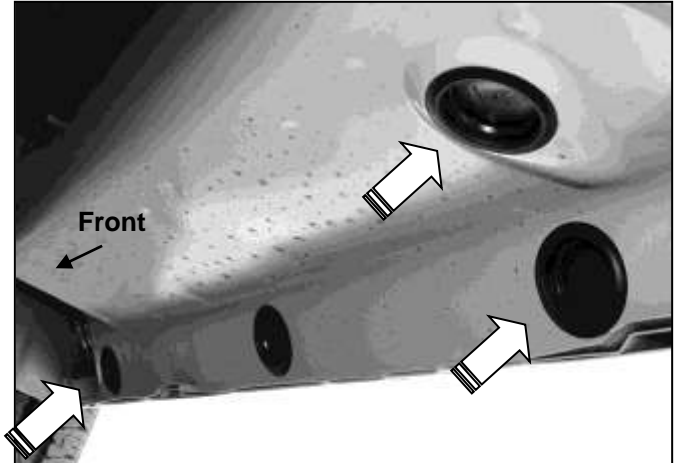

(Fig 14) Remove rubber plugs from (3) passenger side front and #2 Bracket mounting locations

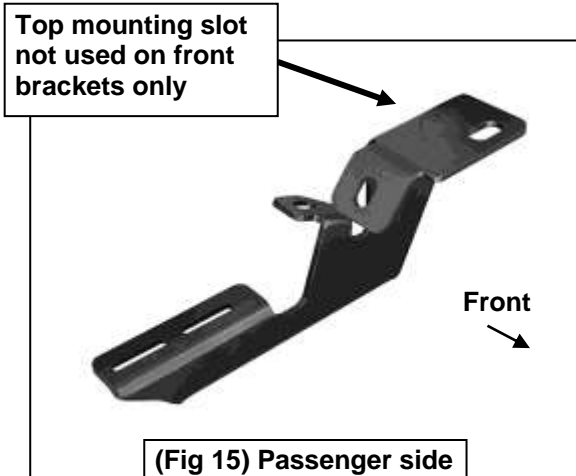

(Fig 15) Passenger side front Mounting Bracket

12mm Flat Washer
12mm Lock Washer
12mm Hex Nut

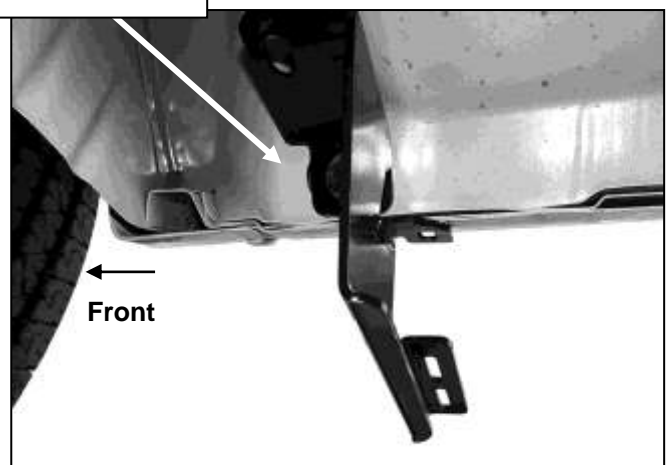

(Fig 16) Passenger/right side front Bracket

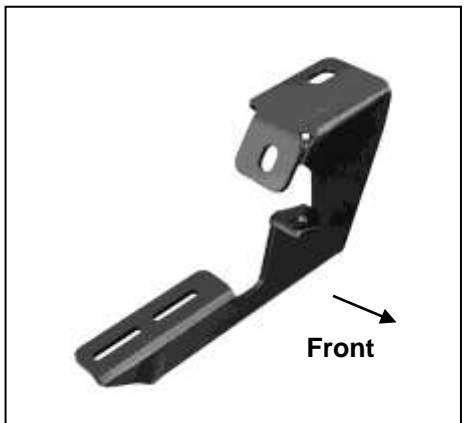

(Fig 17) Passenger side #2 Bracket

Passenger/right side installation pictured

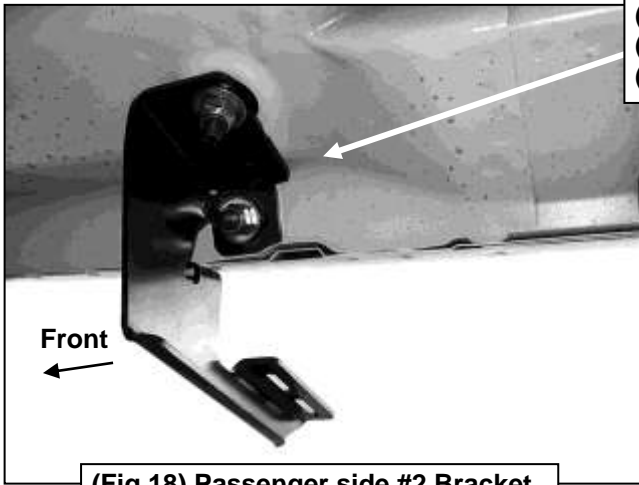

- (2) 12mm Flat Washers
- (2) 12mm Lock Washers
- (2) 12mm Hex Nuts

(Fig 18) Passenger side #2 Bracket

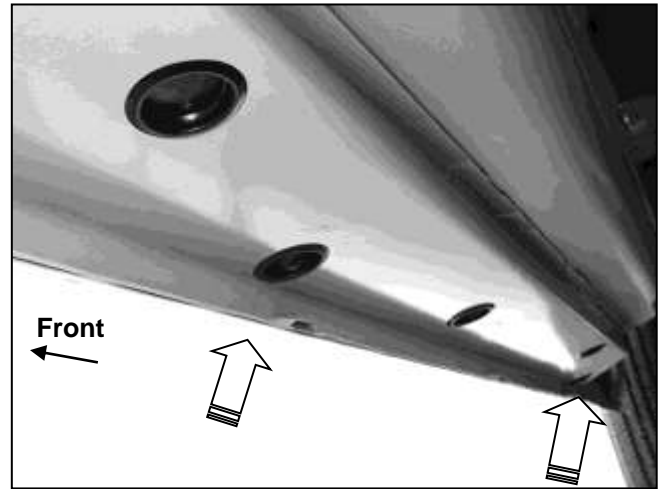

(Fig 19) Passenger side #3 and rear mounting locations (arrows)



(Fig 20) Passenger/right #3 and/or rear Mounting Bracket

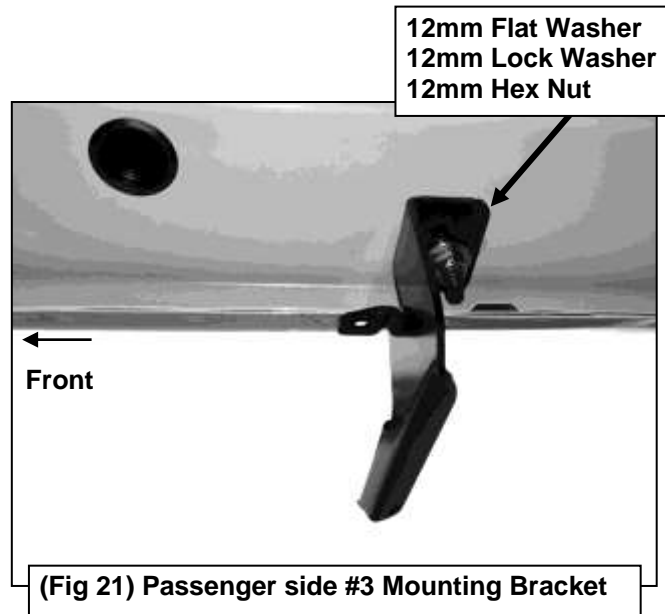

- 12mm Flat Washer
- 12mm Lock Washer
- 12mm Hex Nut

(Fig 21) Passenger side #3 Mounting Bracket

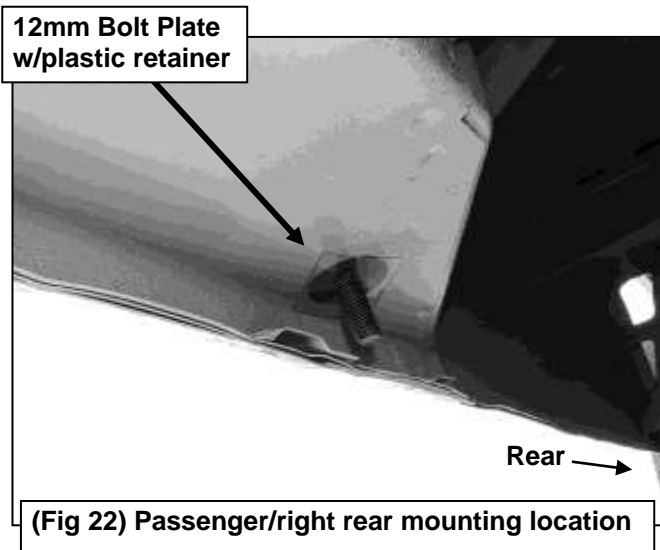

- 12mm Bolt Plate w/plastic retainer

(Fig 22) Passenger/right rear mounting location

Passenger/right side installation pictured

Top mounting slot not used on front brackets only

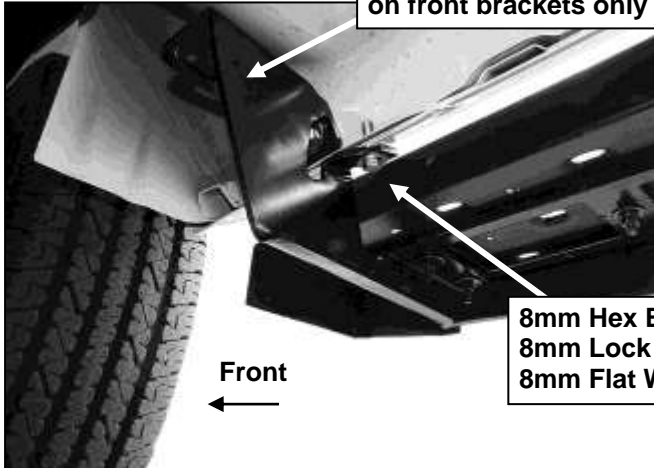

8mm Hex Bolt
8mm Lock Washer
8mm Flat Washer

(Fig 23) Passenger/right front Bracket installation

8mm Hex Bolt
8mm Lock Washer
8mm Flat Washer

(2) 6mm Flat Washer
(2) 6mm Lock Washers
(2) 6mm Hex Nuts

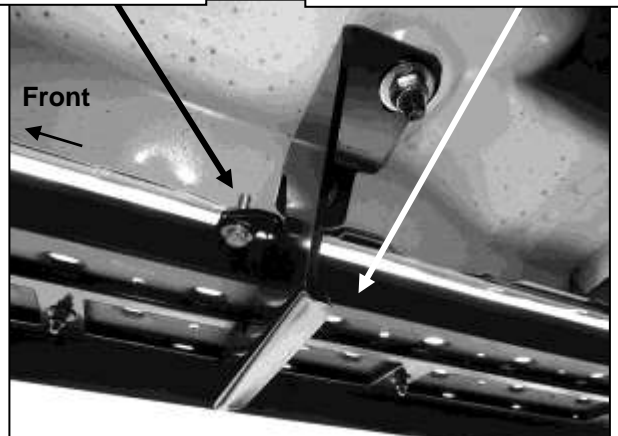

(Fig 24) Passenger/right #2 Bracket installation

8mm Hex Bolt
8mm Lock Washer
8mm Flat Washer

(2) 6mm Flat Washer
(2) 6mm Lock Washers
(2) 6mm Hex Nuts

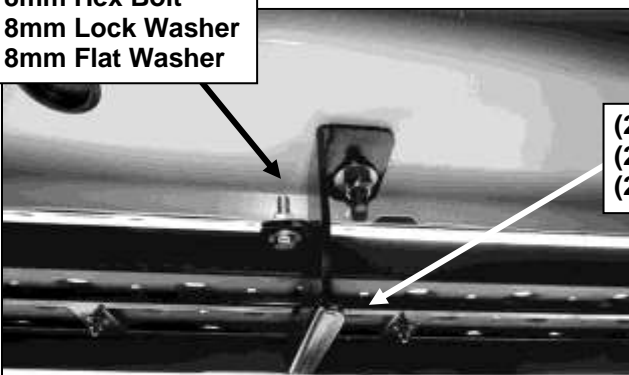

(Fig 25) Passenger/right #3 Bracket installation

8mm Hex Bolt
8mm Lock Washer
8mm Flat Washer



(Fig 26) Passenger/right rear Bracket installation



Complete Installation