

PARTS LIST:

2	Rattler Running Boards (76in)	6	6mm x 30mm Double Bolt Plates
3	Driver/left side Mounting Brackets	12	6mm x 22mm x 2mm Flat Washers
3	Passenger/right side Mounting Brackets	12	6mm Lock Washers
18	8mm x 24mm x 2mm Flat Washers	12	6mm Hex Nuts
18	8-1.25mm Nylon Lock Nuts		

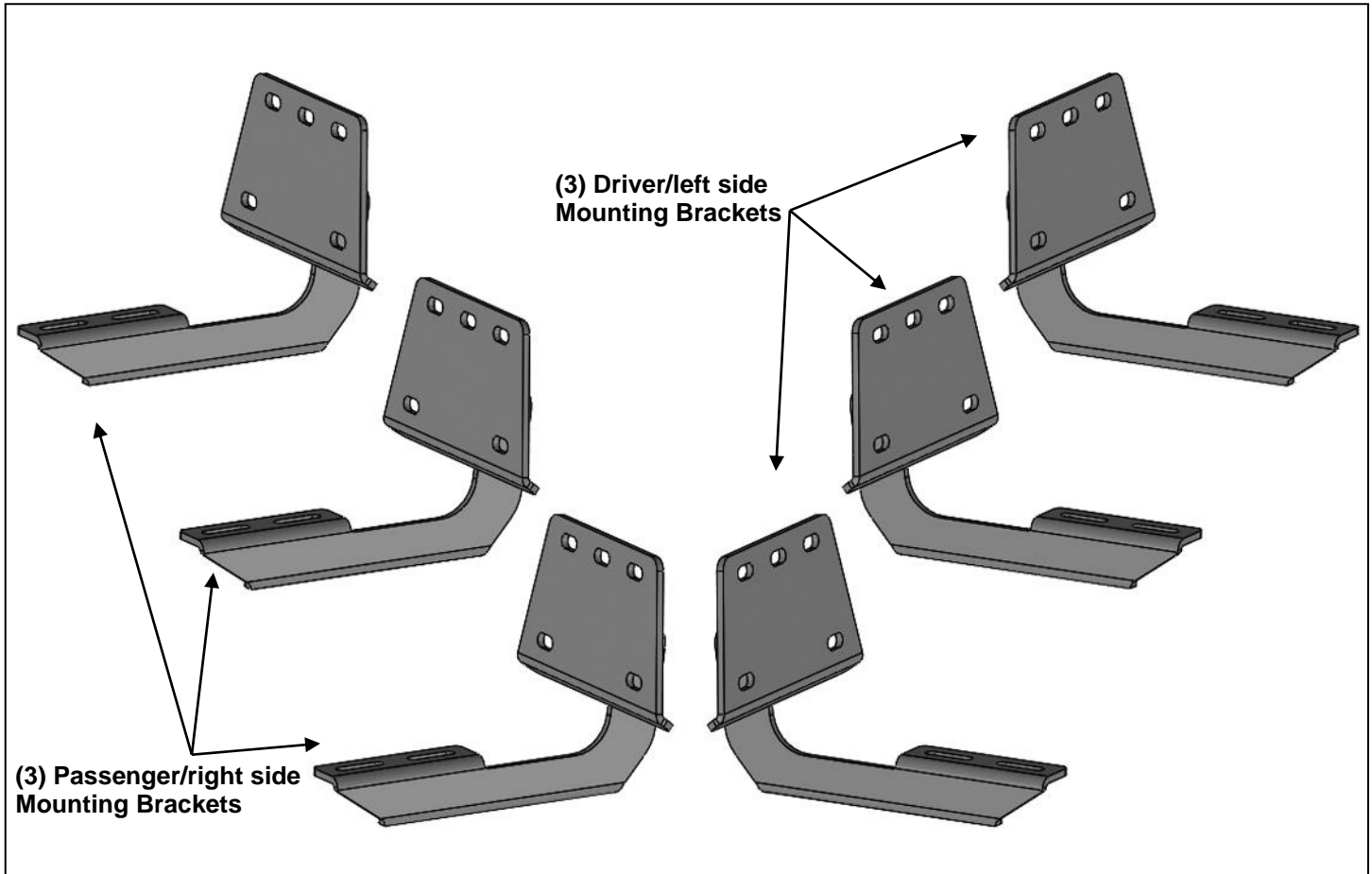

PROCEDURE:

REMOVE CONTENTS FROM BOX. VERIFY ALL PARTS ARE PRESENT. READ INSTRUCTIONS CAREFULLY BEFORE STARTING INSTALLATION. ASSISTANCE IS RECOMMENDED.

1. Start the installation under the driver side of the vehicle. Locate the front (3) factory studs along the inner side of the body panel, **(Figure 1)**. **NOTE:** Use a wire brush or die to remove paint buildup on the threaded studs.
2. Select (1) Driver/left side Mounting Bracket. **NOTE:** When installed properly, the flanges on the Brackets will face towards the rear. Attach the Mounting Bracket to the (3) factory studs with (3) 8mm Flat Washers and (3) 8mm Nylon Lock Nuts, **(Figure 2)**. Leave brackets loose at this time.
3. Repeat **Steps 1 & 2** to install the remaining Driver/left side Brackets in the center and rear mounting locations along the body panel, **(Figures 3 & 4)**.
4. Carefully unwrap and select (1) Running Board. Place the Running Board on top of the Brackets. **IMPORTANT:** Do not slide, (front to back), the Running Board on the Brackets or damage to the finish may result. Locate the channel opening in the bottom of the Running Board. Select (3) 6mm Double Bolt Plates, **(Figure 5)**. Insert the Bolt Plates into the channel in the bottom of the Running Board closest to the Brackets, **(Figure 6)**. Lift the Running Board up and guide the studs through the Brackets.

5. Attach the Running Board to the Brackets with (6) 6mm Flat Washers, (6) 6mm Lock Washers and (6) 6mm Hex Nuts, **(Figures 7—9)**.
6. Level and adjust the Running Board as necessary and fully tighten all hardware.
7. Repeat **Steps 1—6** for Running Board installation on the passenger/right side.
8. Do periodic inspections to the installation to make sure that all hardware is secure and tight.

To protect your investment, wax this product after installing. Regular waxing is recommended to add a protective layer over the finish. Do not use any type of polish or wax that may contain abrasives that could damage the finish. Mild soap may be used also to clean the Running Board.

Driver/left Side Installation Pictured

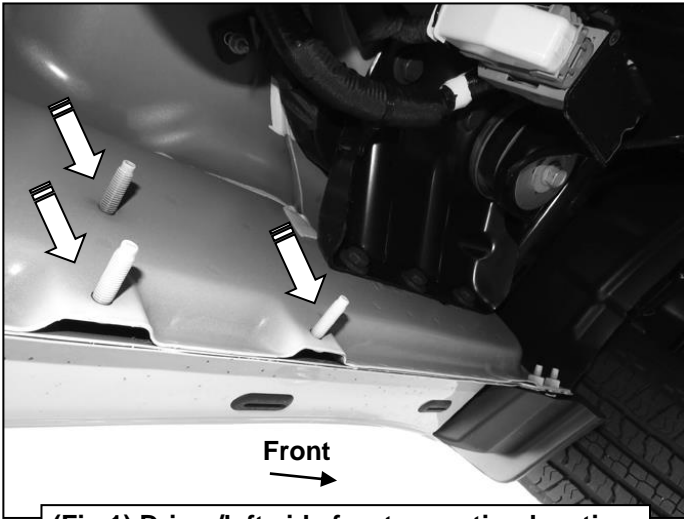

(Fig 1) Driver/left side front mounting location

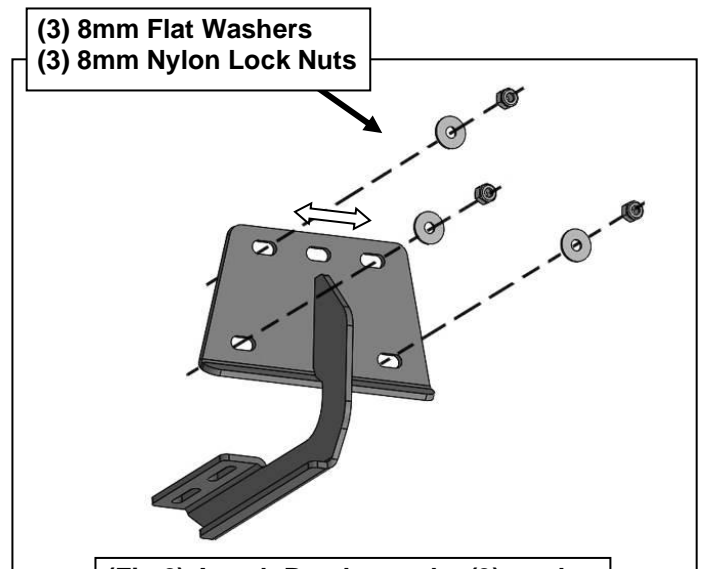

(Fig 2) Attach Bracket to the (3) studs



(Fig 3) Driver/left side center mounting location

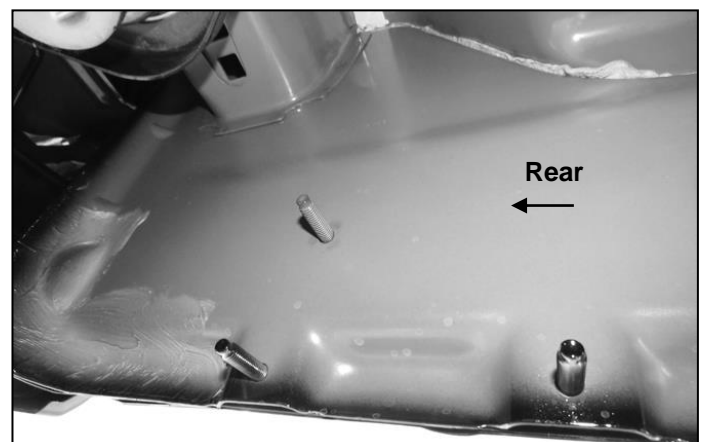

(Fig 4) Driver/left side rear mounting location

Driver/left Side Installation Pictured



(Fig 5) 6mm Double Bolt Plate

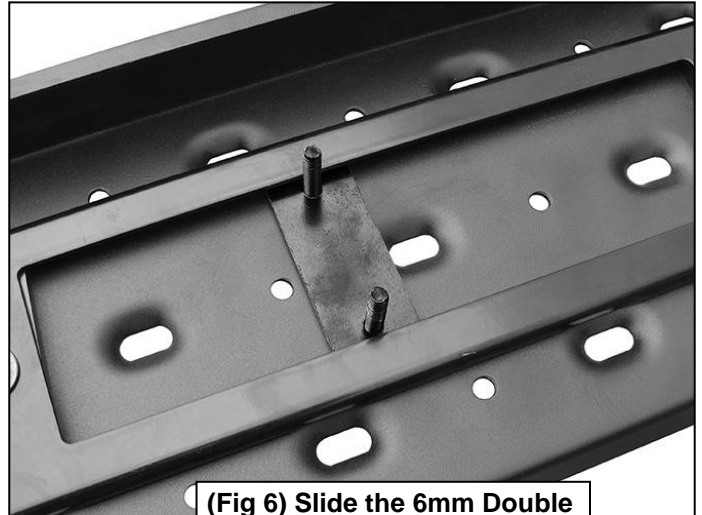

(Fig 6) Slide the 6mm Double Bolt Plate into channels

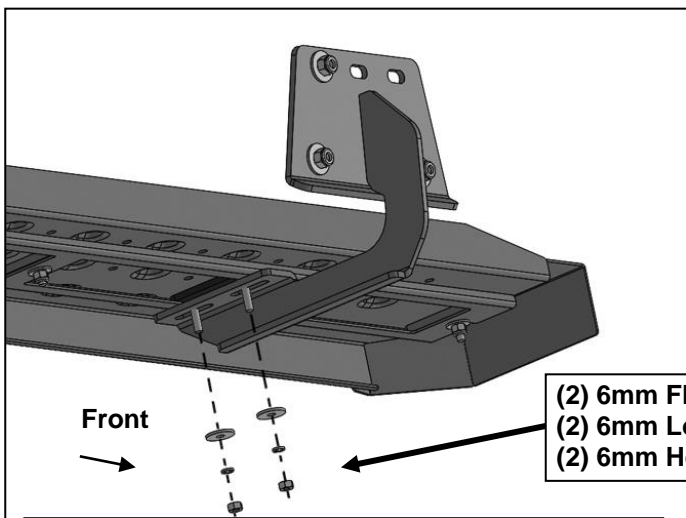

(Fig 7) Front Bracket attached to Running Board

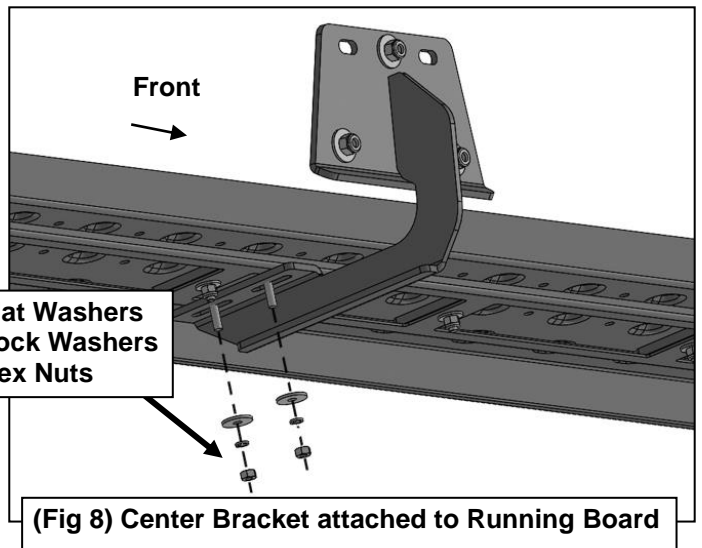

(Fig 8) Center Bracket attached to Running Board

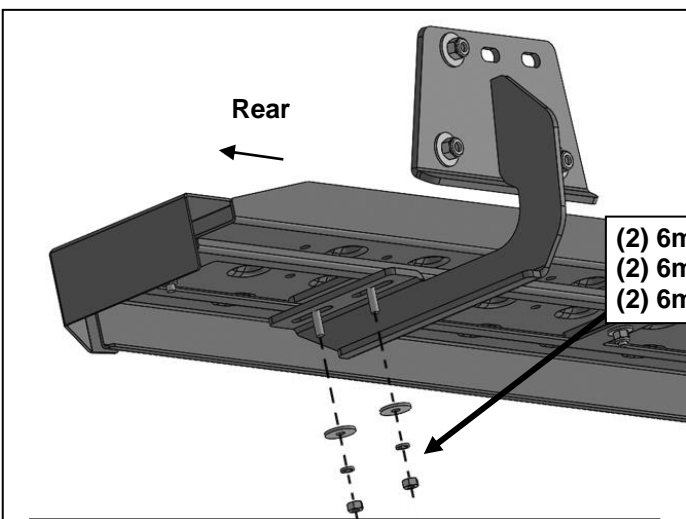

(Fig 9) Rear Bracket attached to Running Board