

PARTS LIST:

1	Driver/Left Rattler Running Board	6	10mm Hex Nuts
1	Passenger/Right Rattler Running Board	12	8-1.25mm x 30mm Hex Bolts
1	Driver/Left Front Mounting Bracket	24	8mm x 24mm OD x 2mm Flat Washers
1	Driver/Left Rear Mounting Bracket	12	8mm Lock Washers
1	Passenger/Right Front Mounting Bracket	12	8mm Hex Nuts
3	Passenger/Right Mounting Brackets	6	6mm Double Bolt Plates
6	Support Brackets	12	6-1.25mm x 30mm Hex Bolts
6	10-1.5mm x 30mm Bolt Plates	12	6mm x 22mm OD x 2mm Flat Washers
6	10mm Plastic Retainers	24	6mm x 18mm OD x 1.6mm Flat Washers
6	10mm x 24mm OD x 2.2mm Flat Washers	24	6mm Lock Washers
6	10mm Lock Washers	24	6mm Hex Nuts

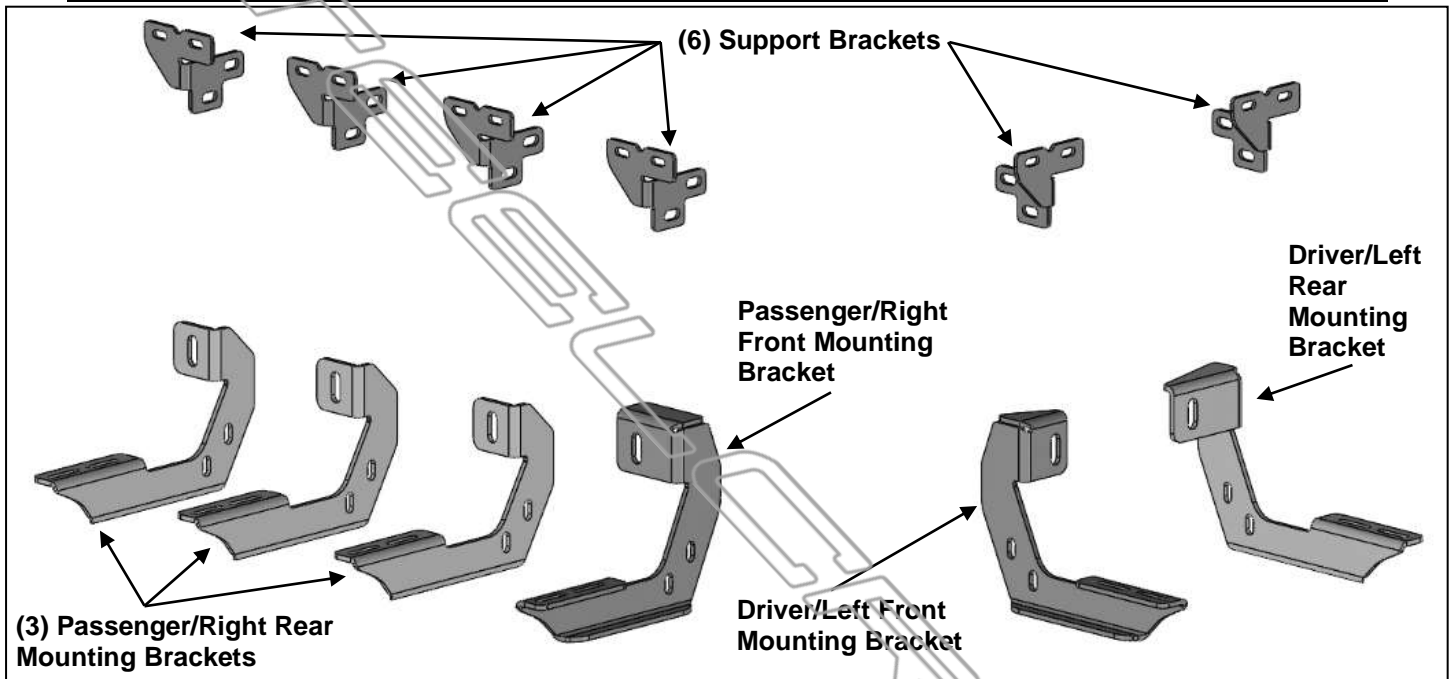

PROCEDURE:

1. REMOVE CONTENTS FROM BOX. VERIFY ALL PARTS ARE PRESENT. READ INSTRUCTIONS CAREFULLY BEFORE STARTING INSTALLATION. DRILLING IS REQUIRED. ASSISTANCE IS RECOMMENDED.
2. Starting on the Passenger/Right side of the vehicle, locate the 2nd factory hole in the inner body panel from the front tire opening, (**Figures 1 & 2**). Remove the rubber plug. **NOTE:** Mounting locations may be covered with heavy undercoating. Refer to instructions to find all mounting locations.
3. Select (1) 10mm Bolt Plate. Insert the Bolt Plate into the mounting hole. Thread (1) 10mm Plastic retainer onto the Bolt Plate to hold it in place, (**Figure 3**).
4. Select the unique Passenger/Right Front Bracket. Attach the Bracket to the Bolt Plate with (1) 10mm Flat Washer, (1) 10mm Lock Washer and (1) 10mm Hex Nut, (**Figure 4**). Do not tighten hardware.
5. Next, select (1) Support Bracket. Attach the Support Bracket to the front face of the Passenger/Right Front Mounting Bracket with (2) 8mm x 30mm Hex Bolts, (4) 8mm Flat Washers, (2) 8mm Lock washers and (2) 8mm Hex Nuts, (**Figure 5**). Line up the mounting flange on the Support Bracket with the **outside** of the pinch weld. Do not tighten hardware.
6. Repeat **Steps 2—5** to attach the (3) Passenger/Right Mounting Brackets and (3) Support Brackets to the body panel, (**Figures 6—9**).
7. Select the long passenger side Running Board. Place the Running Board on top of the (4) Brackets. Level and adjust the Running Board and fully tighten the Bracket to vehicle hardware only. Temporarily remove the Running Board.

07-09 DODGE SPRINTER / 07-09 FREIGHTLINER SPRINTER / 10-C MERCEDES SPRINTER

8. Make sure the Brackets are level to the vehicle. Line up the slots on each Support Bracket with the outside of the pinch weld. Mark the location of the slots onto the pinch weld, **(Figure 10)**. **IMPORTANT:** Do not drill too close to the bottom edge of the pinch weld. Adjust Support Brackets and/or Mounting Brackets so that slots in Support Brackets are not too close to the bottom edge of the pinch weld. Once the Running Board and Brackets are properly adjusted and slot locations marked, remove the Running Board and Support Brackets. Use a 5/16" drill bit to drill the (2) holes through the pinch weld for each Support Bracket.
9. Attach each Support Bracket to the outside of the pinch weld with (2) 6mm Hex Bolts, (4) 6mm x 18mm STD Flat Washers, (2) 6mm Lock Washers and (2) 6mm Hex Nuts, **(Figure 11)**. Repeat this Step to attach the remaining (3) Passenger/Right Support Brackets. Tighten the hardware attaching the Support Brackets to the vehicle only.
10. Select (4) 6mm Double Bolt Plates, **(Figure 12)**. Locate the channels in the bottom of the Running Board, **(Figure 13)**. Insert the Bolt Plates into the channels in the bottom of the Running Board closest to the Brackets. With assistance, guide the studs down through the Mounting Brackets.
11. Attach the Running Board to the Brackets with (8) 6mm x 22mm Large Flat Washers, (8) 6mm Lock Washers and (8) 6mm Hex Nuts, **(Figure 14)**. **NOTE:** The Running Board is designed to fit close to the vehicle. It may be necessary to loosen the Bracket hardware and tilt the Brackets downward to insert the Running Board between the Brackets and the body. Level and adjust the Running Board and fully tighten all hardware.
12. Move to the Driver/Left side of the vehicle. Remove the undercoating and the rubber plugs from the 2nd and 3rd mounting locations. Repeat **Steps 3—5** to attach the Driver/Left Front Mounting Bracket and (1) Support Bracket to the 2nd mounting location in the body panel, **(Figures 15—18)**. Do not tighten hardware at this time.
13. Repeat **Step 12** to attach the Driver/Left Rear Mounting Bracket and (1) Support Bracket to the 3rd mounting location on the body panel.
14. Select the Driver/Left Running Board. Repeat **Steps 7—11** to drill the pinch weld to attach the Support Brackets and Running Board.
15. Level and adjust the Driver/Left Running Board and tighten all hardware.
16. Do periodic inspections to the installation to make sure that all hardware is secure and tight.

To protect your investment, Do not use any type of polish or wax that may contain abrasives that could damage the finish. Use Mild soap to clean the Running Board.

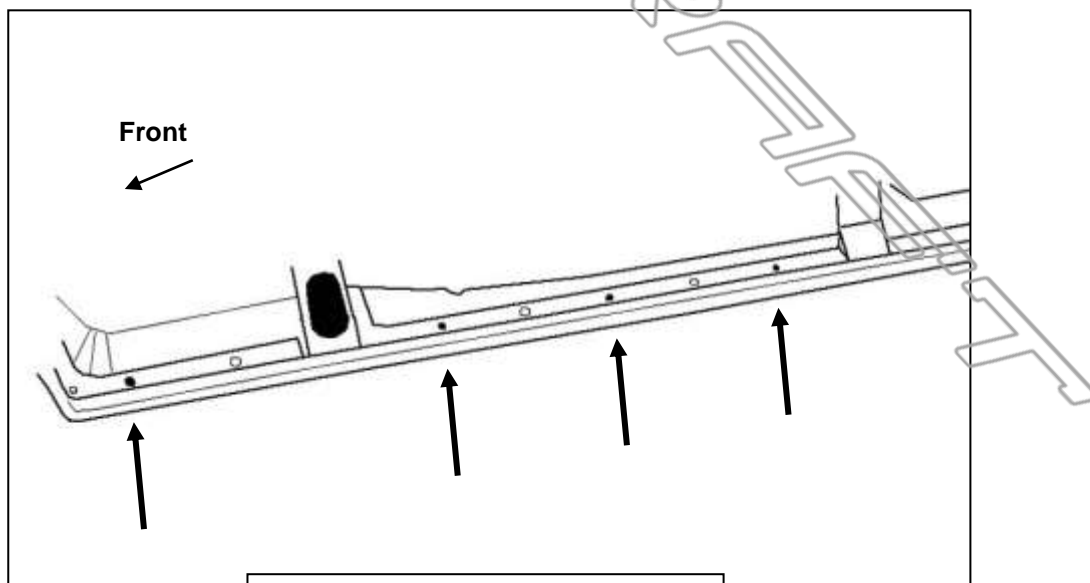
Passenger/Right Side Installation Pictured**Passenger/Right Side Installation Pictured**

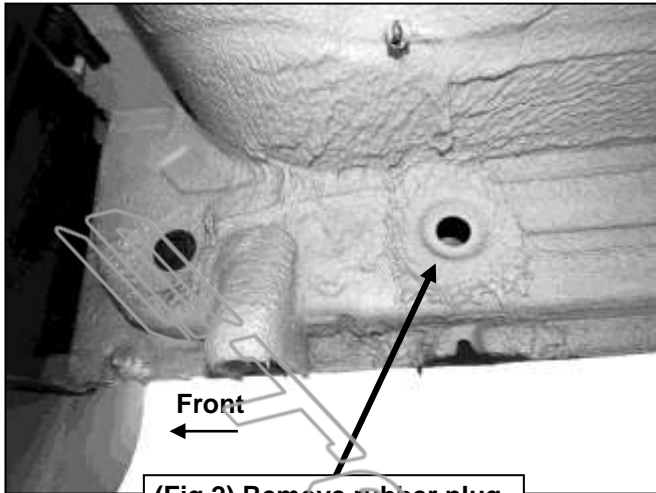

(Fig 2) Remove rubber plug

- 10mm Flat Washer
- 10mm Lock Washer
- 10mm Hex Nut

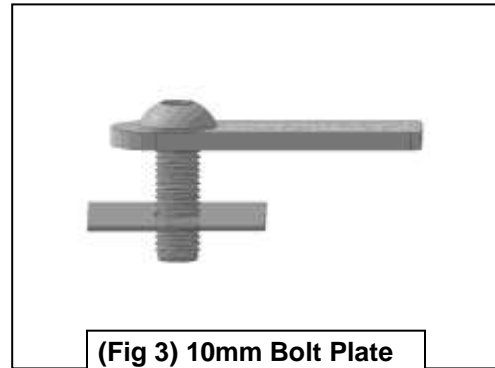

(Fig 3) 10mm Bolt Plate with Plastic Retainer

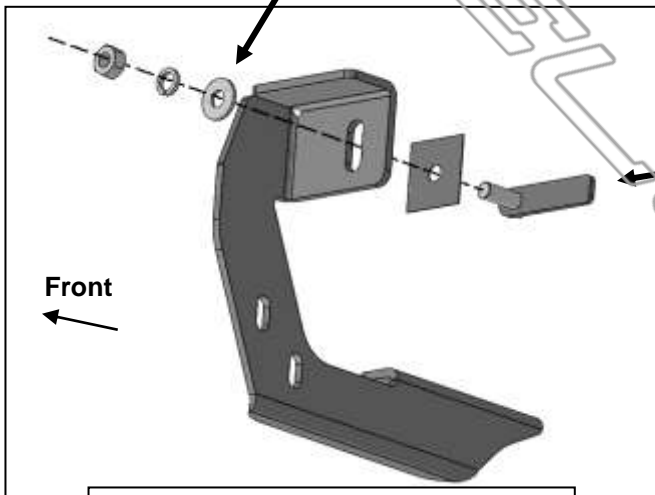

(Fig 4) Attach Passenger/Right Front Mounting Bracket to the body panel

- 10mm Bolt Plate
- 10mm Plastic Retainer

Support Bracket

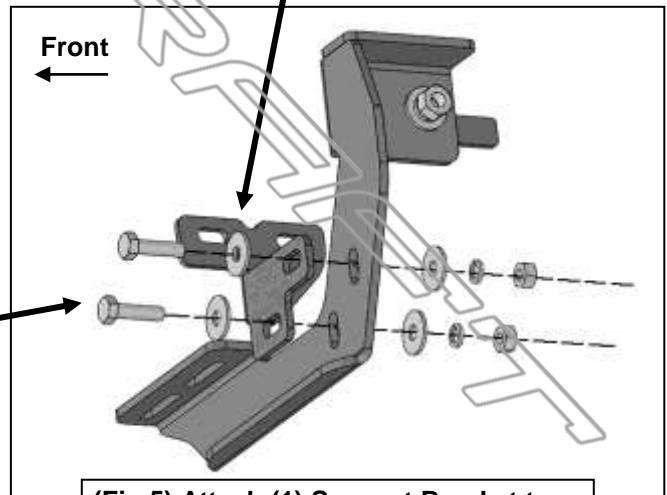

(Fig 5) Attach (1) Support Bracket to the front face of the Mounting Bracket

- (2) 8mm x 30mm Hex Bolts
- (4) 8mm Flat Washers
- (2) 8mm Lock Washers
- (2) 8mm Hex Nuts

Passenger Side Installation Pictured



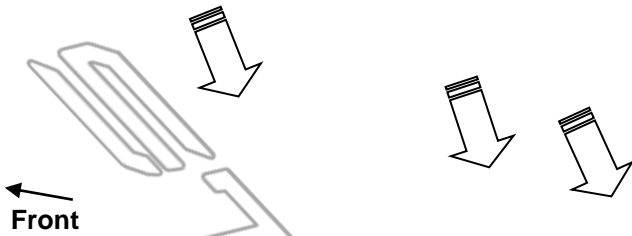

(Fig 6) Rear mounting locations (arrows)

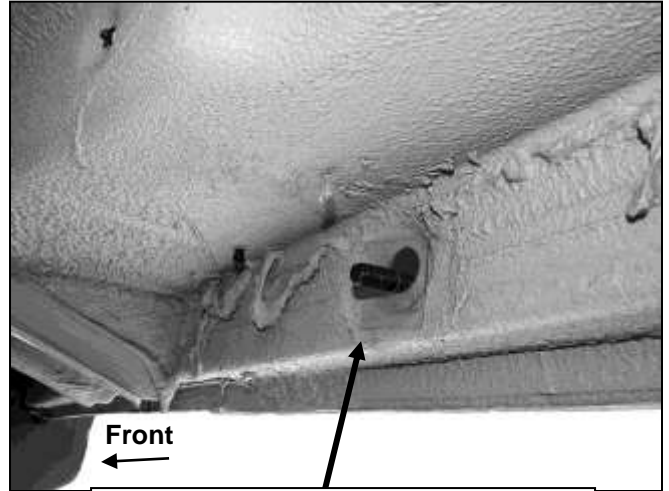

(Fig 7) Bolt Plate with Plastic Retainer inserted in #2 mounting location

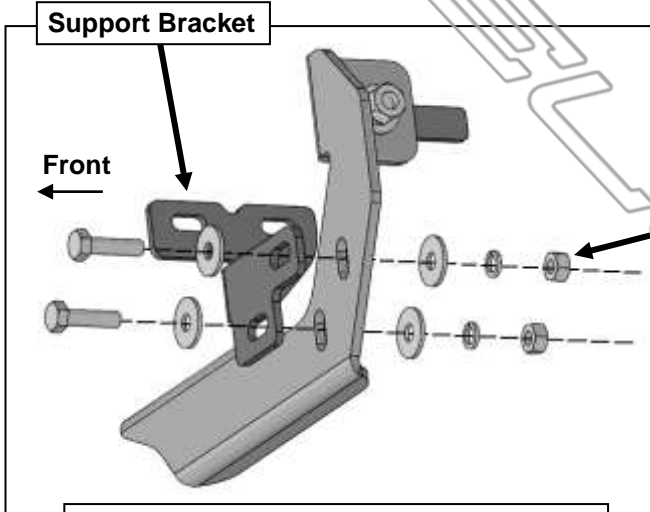

(Fig 8) Attach Support Brackets to the (3) rear Passenger/Right Mounting Bracket

- (2) 8mm x 30mm Hex Bolts
- (4) 8mm Flat Washers
- (2) 8mm Lock Washers
- (2) 8mm Hex Nuts

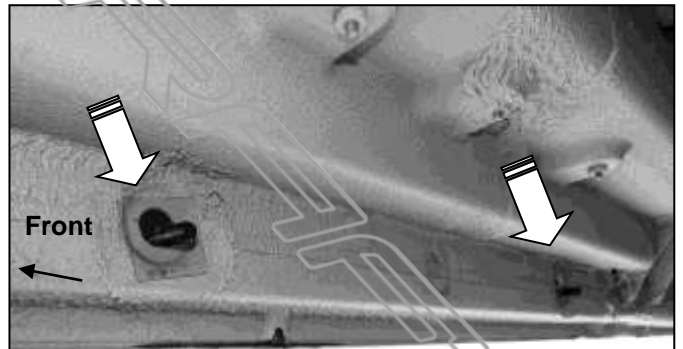

(Fig 9) Bolt Plates with Plastic Retainers installed in #3 and rear mounting locations (arrows)

Passenger Side Installation Pictured

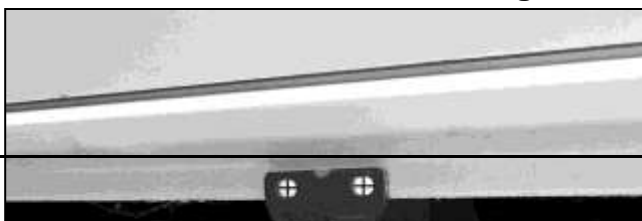

- (2) 6mm x 30mm Hex Bolts
- (4) 6mm x 18mm STD Flat Washers
- (2) 6mm Lock Washers
- (2) 6mm Hex Nuts

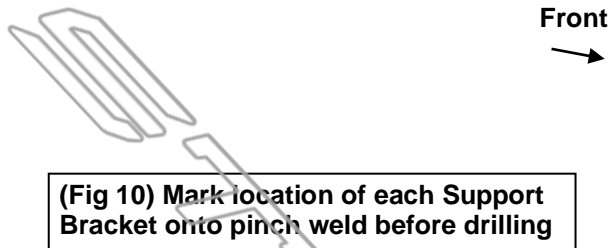

(Fig 10) Mark location of each Support Bracket onto pinch weld before drilling

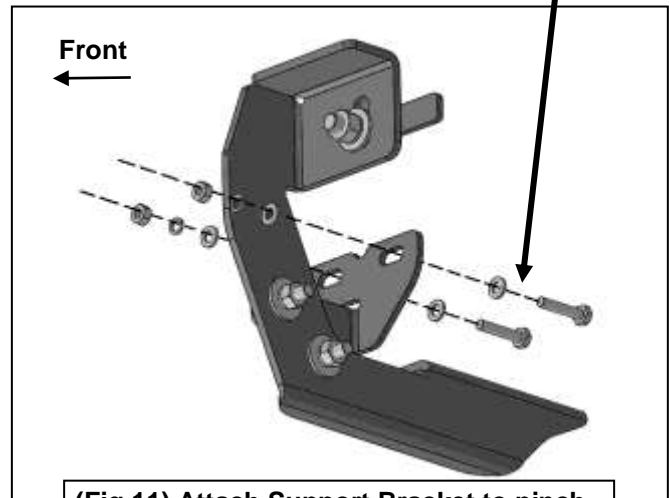

(Fig 11) Attach Support Bracket to pinch weld (passenger front Bracket illustrated)



(Fig 12) Double Bolt Plate

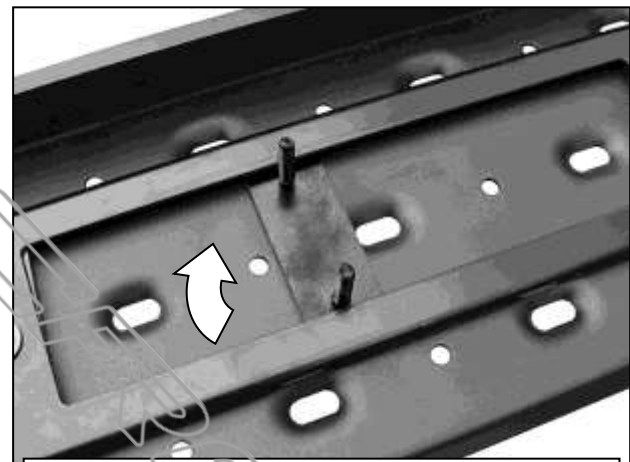

(Fig 13) Slide Double Bolt Plate into channels

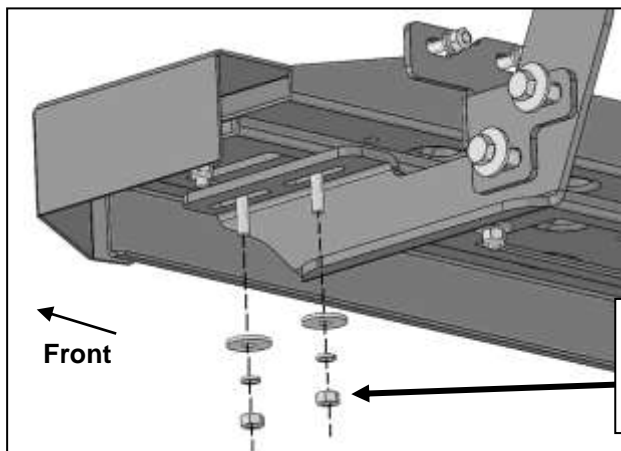

(Fig 14) Attach the Passenger/Right Running Board to the (4) Mounting Brackets

- (2) 6mm x 22mm Large Flat Washers
- (2) 6mm Lock Washers
- (2) 6mm Hex Nuts

Driver Side Installation Pictured

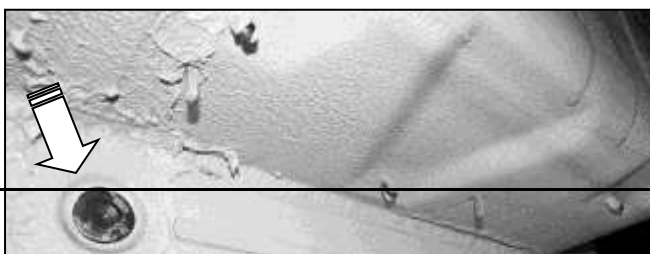

10mm Bolt Plate
10mm Plastic Retainer

07-09 DODGE SPRINTER / 07-09 FREIGHTLINER SPRINTER / 10-C MERCEDES SPRINTER

STX600 RUNNING BOARD



(Fig 15) Driver/Left mounting locations (arrows)

10mm Bolt Plate
10mm Plastic Retainer

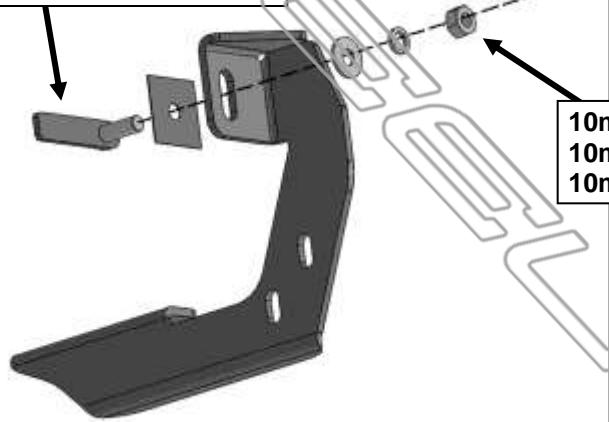

(Fig 17) Attach the Driver/Left Front Mounting Bracket to the rocker panel

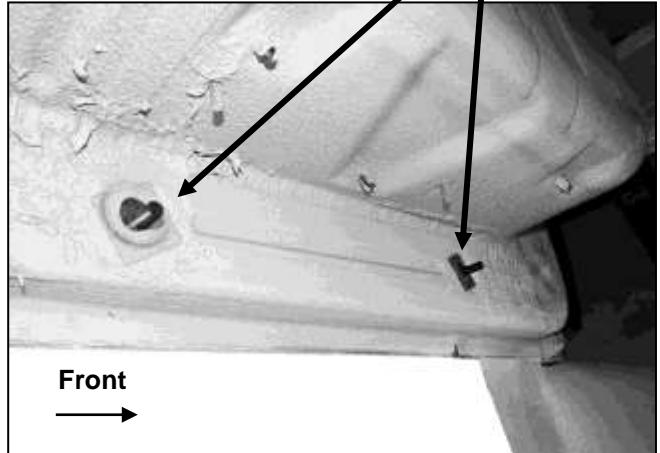

(Fig 16) Bolt Plates with Plastic Retainers inserted in Driver/Left front and rear mounting locations

10mm Flat Washer
10mm Lock Washer
10mm Hex Nut

(2) 8mm x 30mm Hex Bolts
(4) 8mm Flat Washers
(2) 8mm Lock Washers
(2) 8mm Hex Nuts

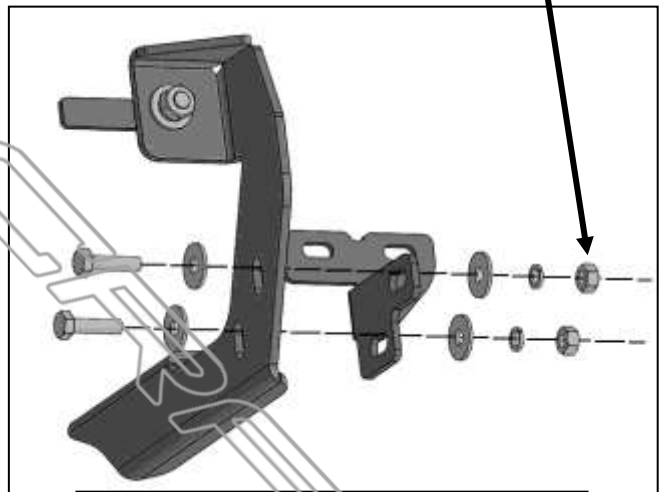

(Fig 18) Attach (1) Support Bracket to the front face of the Mounting Bracket

