

PARTS LIST:

2	Rattler Running Boards (78in)	6	6mm x 30mm Double Bolt Plates
6	Mounting Brackets	12	6mm x 22mm x 2mm Flat Washers
12	8-1.25mm x 30mm Hex Bolts	12	6mm Lock Washers
12	8mm Lock Washers	12	6mm Hex Nuts
12	8mm x 24mm x 2mm Flat Washers		

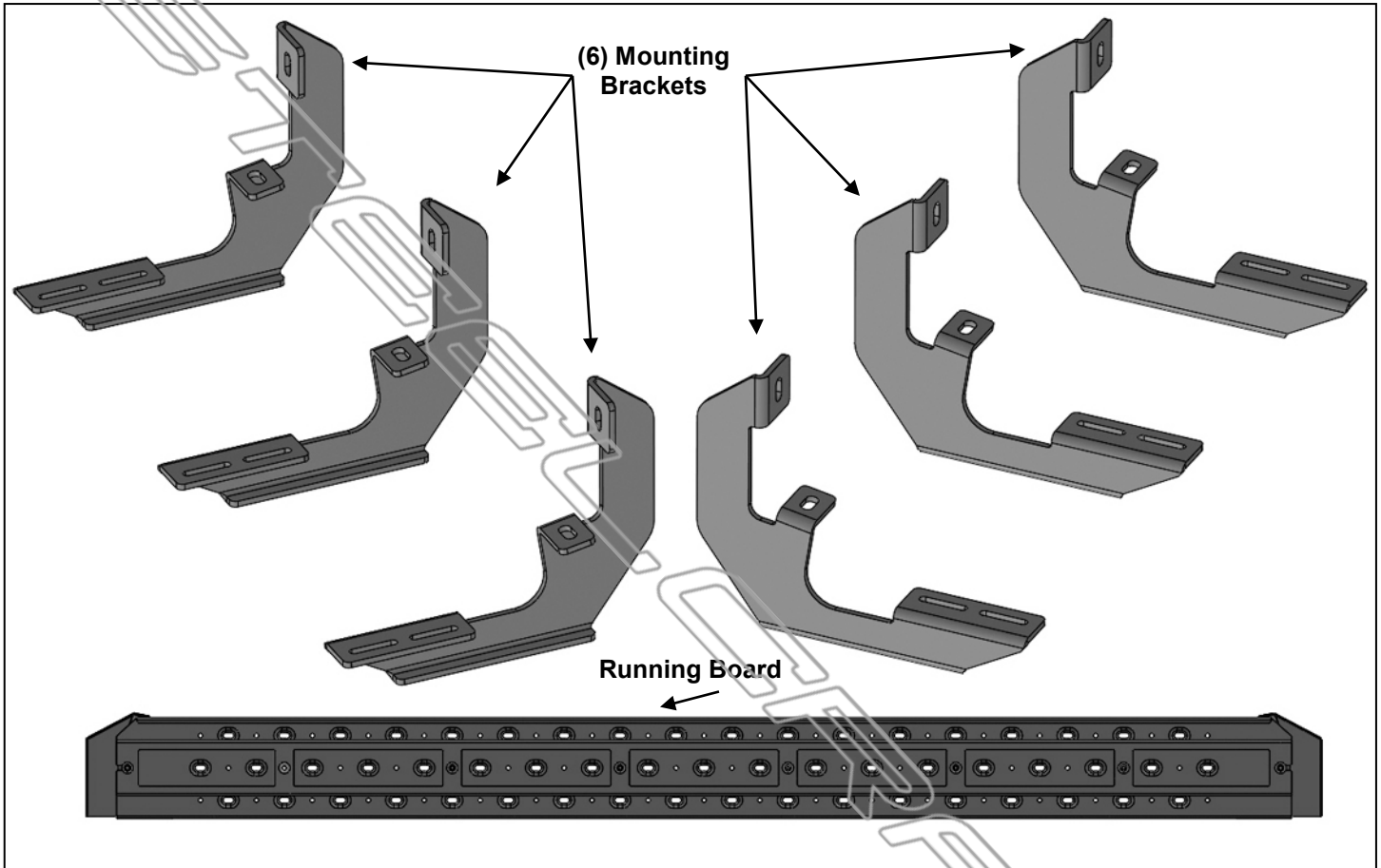

PROCEDURE:

REMOVE CONTENTS FROM BOX. VERIFY ALL PARTS ARE PRESENT. READ INSTRUCTIONS CAREFULLY BEFORE STARTING INSTALLATION. ASSISTANCE IS RECOMMENDED

1. Start the installation under the passenger side of the vehicle. Locate the 4 plugs along the bottom edge of the body. Mounting Brackets will bolt to the 1st, 2nd and 4th threaded mounting holes, **(Figures 1—4)**. Remove the plastic plugs from each mounting location. Directly above each threaded insert is a top mounting location on the side of the body panel. Hold a Bracket up in place to help determine the mounting holes to use along the body. **NOTE:** Thread an 8mm Hex Bolt into the threaded inserts to clear paint as required.
2. Select (1) Mounting Bracket. Starting at the front of the passenger/right side, bolt the Mounting Bracket to the factory threaded holes with (2) 8mm Hex Bolts, (2) 8mm Lock Washers and (2) 8mm Flat Washers, **(Figures 5 & 6)**. Do not tighten hardware at this time.
3. Repeat **Steps 1 & 2** to install (2) Mounting Brackets on the remaining passenger/right side mounting locations along the body panel.
4. Select (1) Running Board. Place the Running Board on top of the Brackets. **IMPORTANT:** Do not slide, (front to back or rotate), the Running Board on the Brackets or damage to the finish may result. Locate the channel opening in the bottom of the Running Board. Select (3) 6mm Double Bolt Plates. Insert the

Bolt Plates into the channel in the bottom of the Running Board closest to the Brackets, (**Figure 7**). Lift the Running Board up and guide the studs through the Brackets.

5. Attach the Running Board to the Brackets with (6) 6mm Flat Washers, (6) 6mm Lock Washers and (6) 6mm Hex Nuts, (**Figures 8 & 9**).
6. Level and adjust the Running Board and fully tighten all hardware.
7. Repeat **Steps 1—6** to install the Running Board on the driver/left side.
8. Do periodic inspections to the installation to make sure that all hardware is secure and tight.

To protect your investment, wax this product after installing. Regular waxing is recommended to add a protective layer over the finish. Do not use any type of polish or wax that may contain abrasives that could damage the finish. Aluminum polish may be used to polish small scratches and scuffs on the finish. Mild soap may be used also to clean the Running Board.

Passenger/right side Installation Pictured

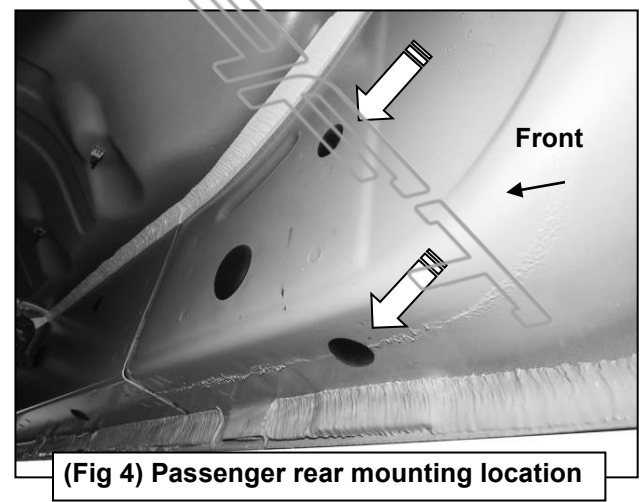
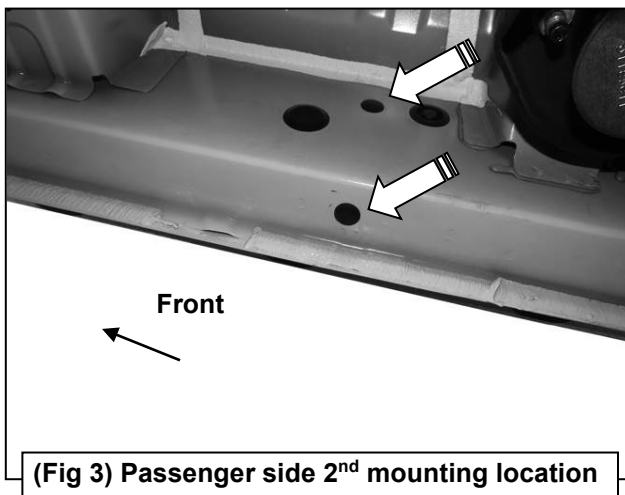
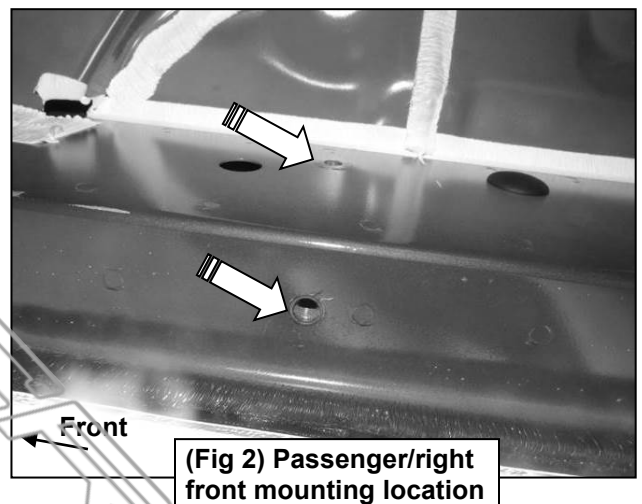
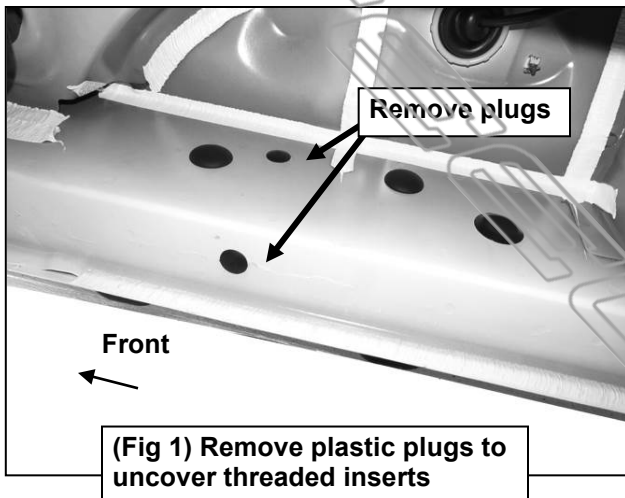

Passenger/right side Installation Pictured

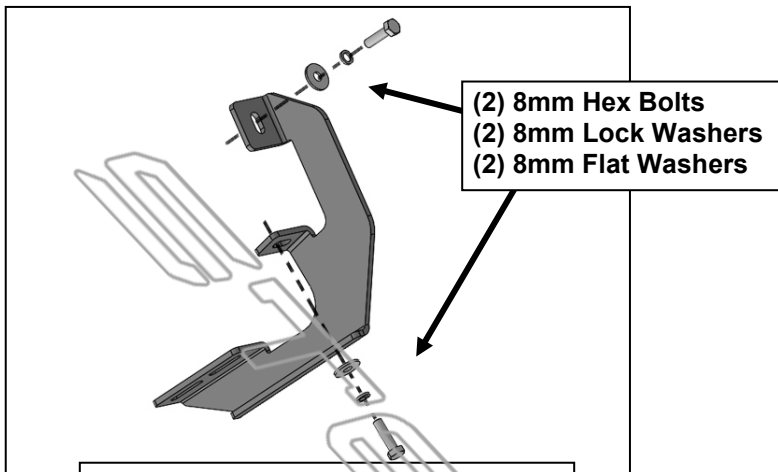

(Fig 5) Mounting Bracket illustration

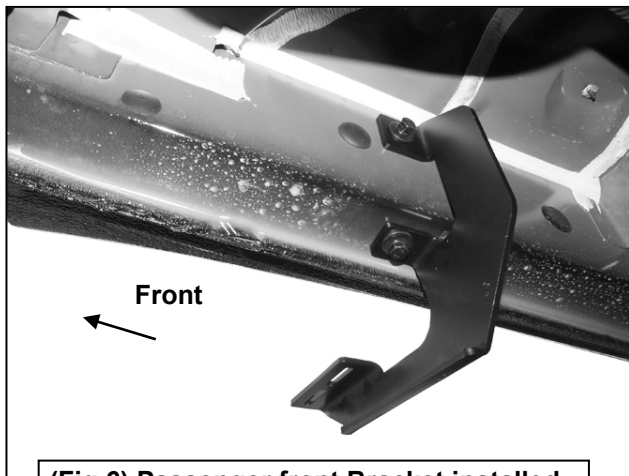

(Fig 6) Passenger front Bracket installed

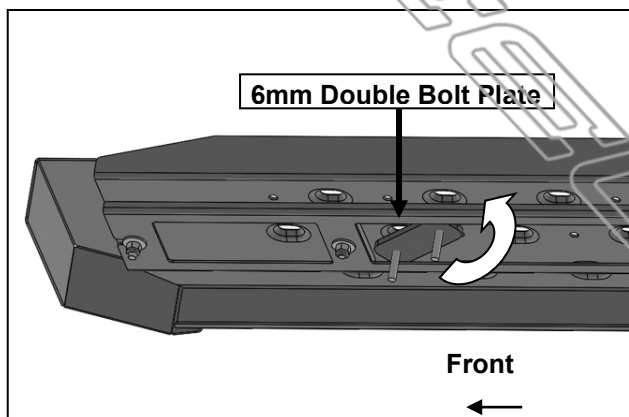

(Fig 7) Insert Bolt Plate in the bottom of the channel on the Running Board

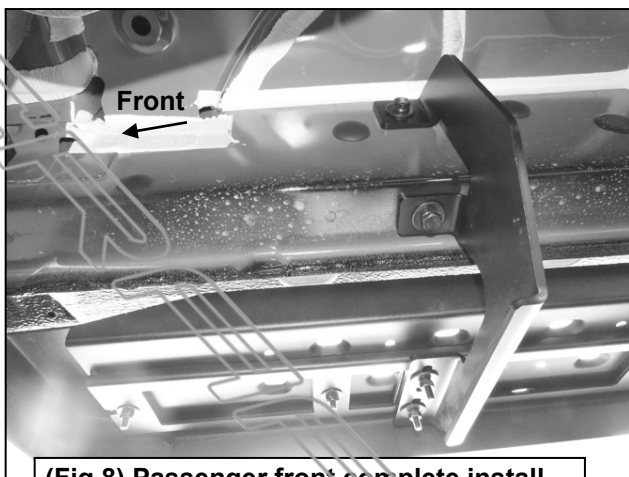

(Fig 8) Passenger front complete install

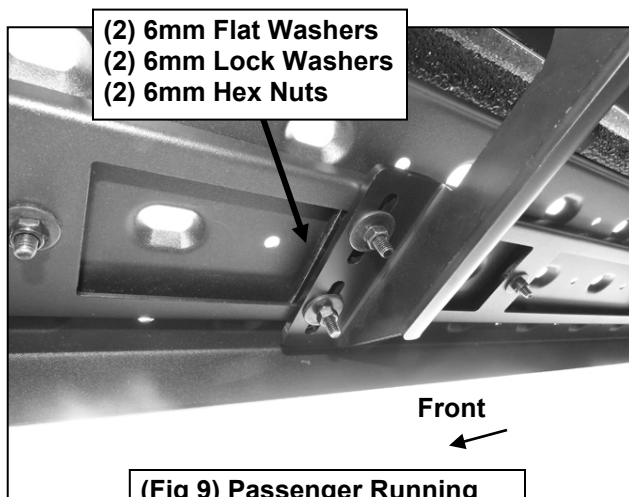

(Fig 9) Passenger Running Board attached to Bracket