



INSTALLATION INSTRUCTIONS



2016 FORD EXPLORER 3.5L | PART NO. 19273

BILL OF MATERIALS:

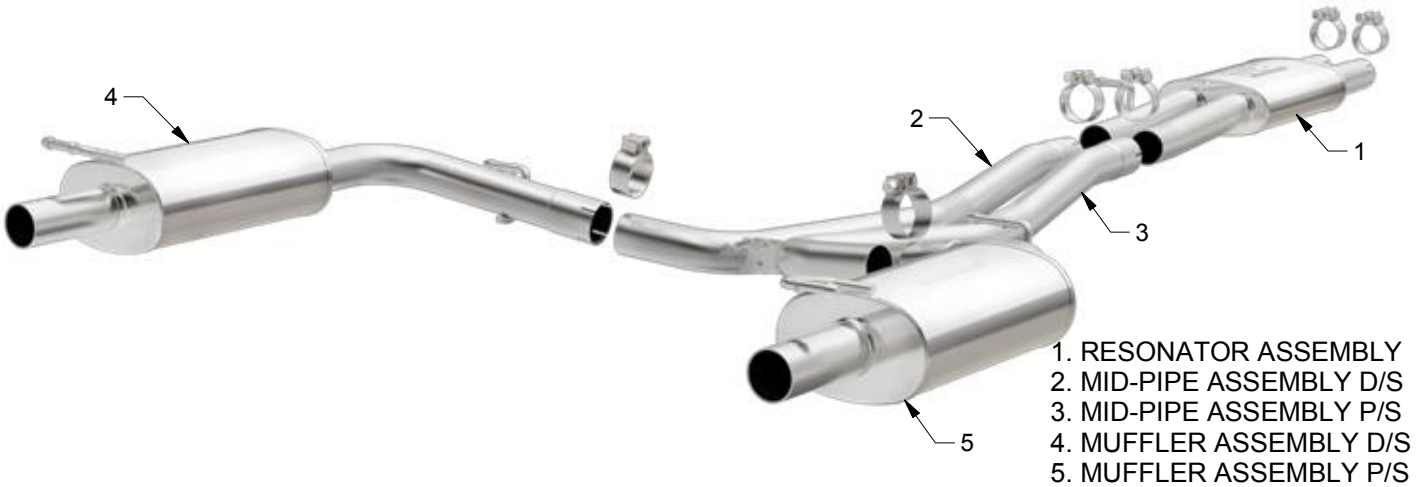

- 1. RESONATOR ASSEMBLY
- 2. MID-PIPE ASSEMBLY D/S
- 3. MID-PIPE ASSEMBLY P/S
- 4. MUFFLER ASSEMBLY D/S
- 5. MUFFLER ASSEMBLY P/S



WEAR SAFETY GLASSES



READ INSTRUCTIONS THOROUGHLY BEFORE INSTALLING PRODUCT

SHOP SUPPLIES:



SPRAY LUBRICANT

To ease removal of existing exhaust components (especially on older vehicles) spray penetrating lubricant on all fasteners and hangers/insulators that will be loosened or removed and let soak before disassembly.

HARDWARE KIT:

- 1. [2] 2.25" Clamp
- 2. [4] 2.50" Clamp
- 3. [2] Bolt 5/16-18x1.00"
- 4. [2] Nut 5/16-18" locking
- 5. [4] Washer 5/16" Flat

MINIMUM REQUIRED TOOLS:



15mm
13mm



Hanger Tool
(Or Pry Bar)



Sawzall or similar cutting device

MAGNAFLOW RECOMMENDS PROFESSIONAL INSTALLATION ON ALL THEIR PRODUCTS



WARNING: When working on, under, or around any vehicle exercise caution. Please allow the vehicle's exhaust system to cool before removal, as exhaust system temperatures may cause severe burns. If working without a lift always consult vehicle manual for correct lifting specifications. Always wear safety glasses and ensure a safe work area. Serious injury or death could occur if safety measures are not followed.

ATTENTION: Always install any supplied band or U-bolt clamps to the proper torque specifications of 40-45 ft-lbs for band clamps and 30-35 ft-lbs for U-bolt clamps. Over tightening will result in the clamp breaking and will NOT be warranted by MagnaFlow.

MAGNAFLOW: 22961 Arroyo Vista - Rancho Santa Margarita, CA 92688 | 1(800) 990-0905
Technical Support: 1(800) 959-9226 | Email: moreinfo@magnaflow.com



Step 1. To remove the OEM exhaust begin by cutting the tubing at the weld junctions in front of the OEM resonator. Once cut, working front to rear, disengage the hangers from the rubber insulators and remove the system. Do not damage or discard the rubber insulators as they will be re-used to install the new Magnaflow system.



Step 2. To install the new Magnaflow exhaust system begin by attaching the Resonator Assembly to the cut and de-burred outlet of the OEM system using the supplied 2.25" clamps. Leave all clamps loose until final adjustment of the system.

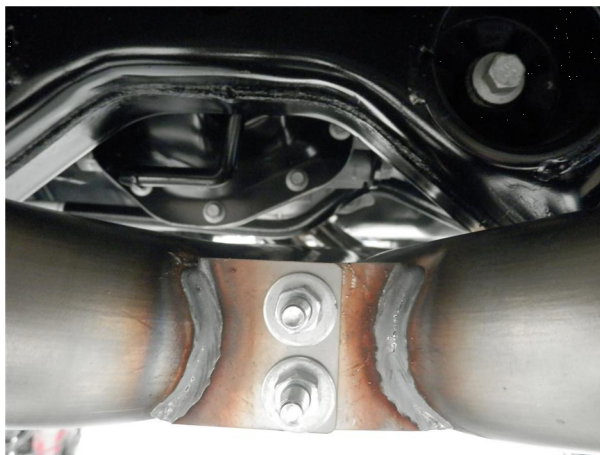
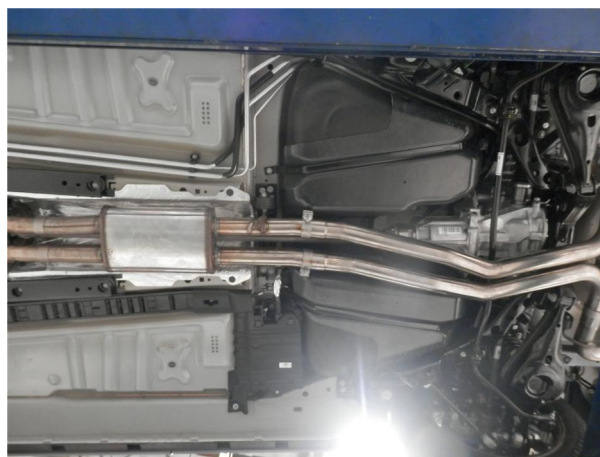

Step 3. Next attach the Mid-Pipe Assemblies to the Resonator Assembly using the supplied 2.50" clamps. At this time also use the supplied 5/16" fasteners to connect the Mid Pipe Assemblies.

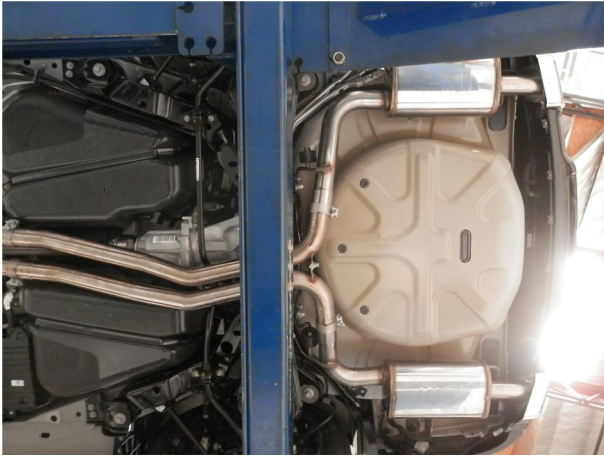

Step 4. Complete the installation by attaching the Muffler Assemblies to the Mid-Pipes using a 2.50" clamps and fitting the tailpipes into the openings in the rear valance and the hangers into the rubber insulators.



Step 5. Once a final position has been chosen for the new exhaust system, evenly tighten all clamps from front to rear using the torque specifications on page one of the instructions. Inspect all fasteners after 25-50 miles of operation and re-tighten if necessary.