



# INSTALLATION INSTRUCTIONS



'14-'15 GRAND CHEROKEE V6 3.6L | PART NO. 19190

## BILL OF MATERIALS:

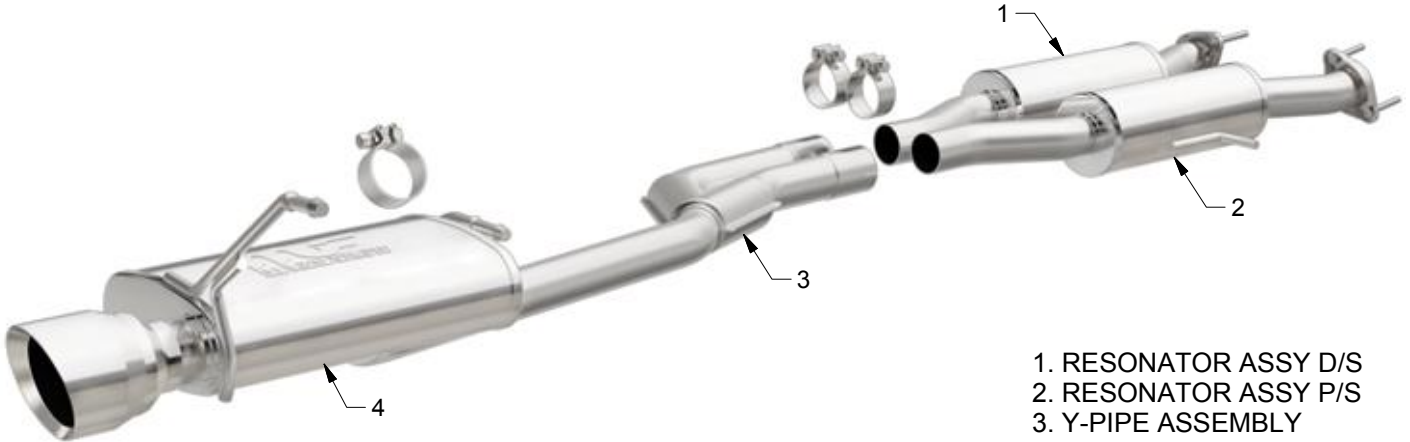

- 1. RESONATOR ASSY D/S
- 2. RESONATOR ASSY P/S
- 3. Y-PIPE ASSEMBLY
- 4. MUFFLER ASSEMBLY T/P



WEAR SAFETY GLASSES



READ INSTRUCTIONS THOROUGHLY BEFORE INSTALLING PRODUCT

## SHOP SUPPLIES:



SPRAY LUBRICANT

To ease removal of existing exhaust components (especially on older vehicles) spray penetrating lubricant on all fasteners and hangers/insulators that will be loosened or removed and let soak before disassembly.

## HARDWARE KIT:

- 1.[3] 2.50" Clamp
- 2.[4] Bolt M10-1.50x70mm

## MINIMUM REQUIRED TOOLS:



15mm  
13mm



Hanger Tool  
(Or Pry Bar)

## MAGNAFLOW RECOMMENDS PROFESSIONAL INSTALLATION ON ALL THEIR PRODUCTS



**WARNING:** When working on, under, or around any vehicle exercise caution. Please allow the vehicle's exhaust system to cool before removal, as exhaust system temperatures may cause severe burns. If working without a lift always consult vehicle manual for correct lifting specifications. Always wear safety glasses and ensure a safe work area. Serious injury or death could occur if safety measures are not followed.

**ATTENTION:** Always install any supplied band or U-bolt clamps to the proper torque specifications of 40-45 ft-lbs for band clamps and 30-35 ft-lbs for U-bolt clamps. Over tightening will result in the clamp breaking and will NOT be warranted by MagnaFlow.

## INSTALLATION INSTRUCTIONS

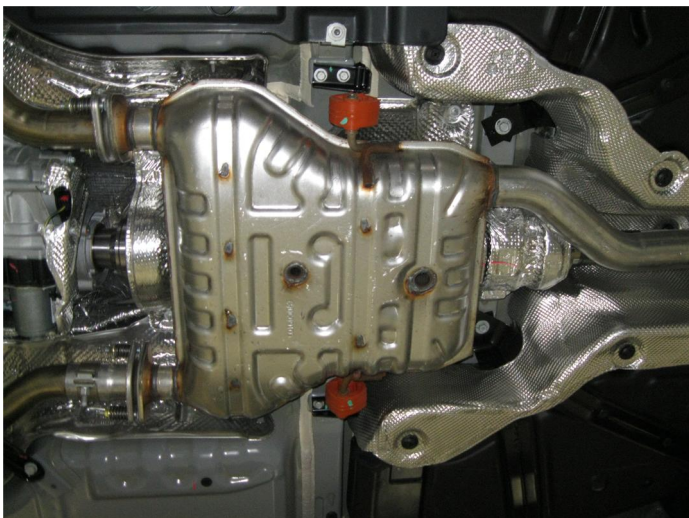

**Step 1.** Begin removing the OEM exhaust system by unbolting the two flanges in front of the main muffler. Working front to rear remove all welded hangers from the rubber insulators. The OEM exhaust system can now be removed in one piece. Retain all mounting hardware and rubber insulators as they will be needing to mount your new MAGNAFLOW system.



**Step 2.** Begin installing your new system by first loosely attaching both Resonator Assemblies to the vehicle outlet flanges using the four supplied M10 bolts.



**Step 3.** Loosely install the Y-Pipe Assembly to the two Resonator Assemblies using two of the supplied 2.50" clamps.



**Step 4.** Install the Muffler Tail Pipe Assembly in a similar fashion using the remaining 2.50" clamp. Locate all welded hangers to the rubber insulators.

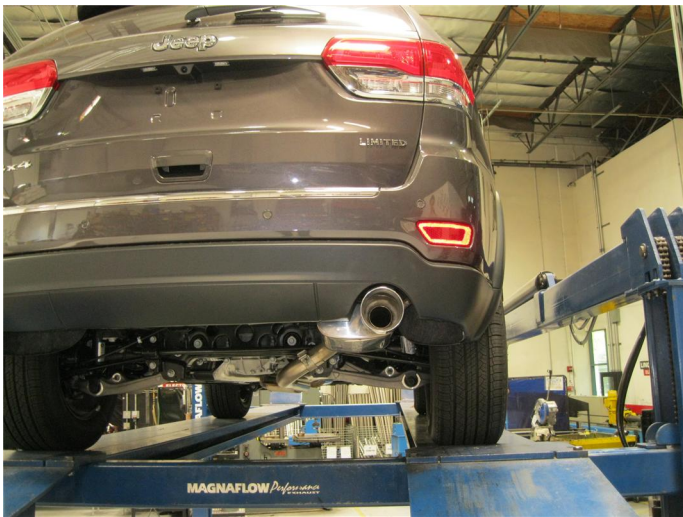

**Step 5.** Once a final position has been chosen for the new exhaust system, evenly tighten all clamps from front to rear using the torque specifications on page one of the instructions. Inspect all fasteners after 25-50 miles of operation and re-tighten if necessary.