

# Installation Instructions for IB20DBB9

by APS Auto Parts Specialist Inc.

**Application:** For 2008-2018 Toyota Highlander Gas & Hybrid (Cutting required)  
**Estimated Time:** 1 to 2 hours



Disclaimer: Instructions intended for persons aged 18+ please do not attempt without adult supervision. Instructions are not intended to replace professional installation. Damage from improper installation, misuse or modification to the product voids the manufacturer's warranty.

**PARTS LIST:**

Item	QTY	Description	Item	QTY	Description
#01	1	Driver/Left Sidebar	#11	2	M12 Lock Washers
#02	1	Passenger/Right Sidebar	#12	2	M12 Hex Nuts
#03	1	Driver/Left Front Mounting Brackets (DFM)	#13	2	M10 Flat Washers
#04	1	Passenger/Right Front Mounting Brackets (PFM)	#14	2	M10 Lock Washer
#05	1	Driver/Left Rear Mounting Brackets (DRM)	#15	2	M10 Hex Nut
#06	1	Passenger/Right Rear Mounting Brackets (PRM)	#16	2	M6 Hex Bolts
#07	2	M12x35 Bolt Plate	#17	18	M6 Flat Washers
#08	2	M10 T-Block Bolt	#18	2	M6 Lock Washers
#09	2	M6 Nut Plate	#19	16	M6 T-Bolts
#10	2	M12 Flat Washers	#20	16	M6 Nylon Lock Nuts

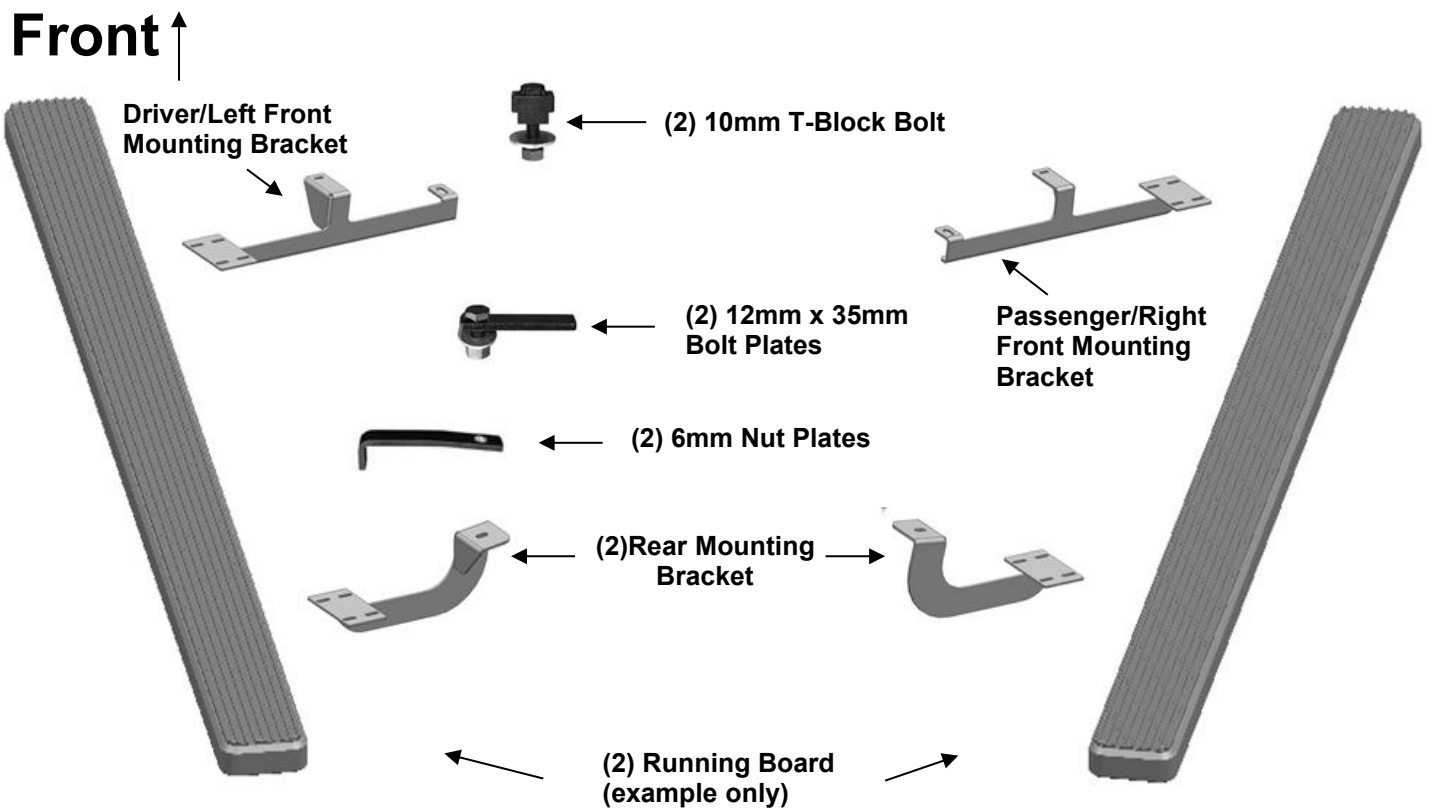

**PROCEDURE:**

**REMOVE CONTENTS FROM BOX. VERIFY ALL PARTS ARE PRESENT. READ FACTORY BODY BOLT REMOVAL INSTRUCTIONS AND INSTALLATION INSTRUCTIONS CAREFULLY BEFORE STARTING INSTALLATION.**

1. Start installation under the driver side of the vehicle. Remove the front and middle section of the plastic splash guard, **(Figure 1A)**. Place the splash guard on a clean, stable work surface.
2. Locate the driver side front mounting location, **(Figure 2)**. Remove the rubber plug from the hole closest to the tie down loop. Insert (1) 12mm x 35mm Bolt Plate into the factory hole, **(Figures 3 & 4)**.
3. Next, select the driver side front Bracket, **(Figure 5)**. Attach the Bracket to the 12mm Bolt Plate with (1) 12mm Flat Washer, (1) 12mm Lock Washer and (1) 12mm Hex Nut, **(Figure 6)**. Leave loose.
4. Line up the mounting tab on the Bracket with the factory hole at the point where the cross member joins the frame rail, **(Figures 2 & 6)**. Insert (1) 6mm Nut Plate into the larger inner hole and line up the nut with the hole toward the outside under the mounting tab on the Bracket, **(Figures 6—8)**.
5. Attach the Mounting Bracket to the 6mm Nut Plate with (1) 6mm x 30mm Hex Bolt, (1) 6mm Lock Washer and (1) 6mm Flat Washer, **(Figure 9)**. Leave hardware loose at this time.

6. Mark the outline of the location of the front Bracket onto the bottom of the vehicle for reference if necessary. Temporarily remove the front Bracket. Hold the plastic covers up in approximate location against the vehicle. Trace the location of the Bracket onto the plastic cover. Use a hack saw or utility knife to cut out an opening 2" x 3-1/2" on the middle splash guard as pictured, **(Figure 11)**. Cut a 1-1/2" x 1-1/2" opening in the front cover, **(Figure 10)**. **IMPORTANT:** Due to different models and years of fitment, area to cut is for reference only. Hold Brackets in position on vehicle to determine appropriate area necessary to cut from splash guards. Cut as little as possible for best fit. Once splash guards are trimmed and checked for Bracket clearance, reinstall the splash guards using the factory fasteners.
7. Reinstall the front Bracket as described in **Steps 4—6**. Do not tighten hardware at this time.
8. Next, move toward the rear and remove the rubber grommet located in the rear floor panel, **(Figure 12)**. Insert (1) 10mm T-Block Bolt into the oval factory hole, **(Figure 13)**. **NOTE:** Insert T-Bolt block up and into the hole. Rotate block 90-degrees so that block is supported across the oval hole, **(Figure 14)**.
9. Select the Rear Mounting Bracket, **(Figure 15)**. Attach the rear Bracket to the T-Bolt with the included (1) 10mm Flat Washer, (1) 10mm Lock Washer and (1) 10mm Hex Nut, **(Figure 16)**. Do not tighten hardware at this time.
10. Select the Running Board. Slip (8) 6mm T-Bolts into each bottom channel **(Figure17)**. Carefully position the Running Board onto the Mounting Brackets. Attach the Running Board to the Mounting Brackets with (4) 6mm T-bolts,(4)6mm flat washers and (4)6mm lock nuts, **(Figure 18)**. Do not tighten hardware at this time.
11. Level and adjust the Running Board and fully tighten all hardware. **NOTE: Torque all M6 nylon lock nuts to 7 lb-ft.**
12. Repeat **Steps 1—11** for driver side Running Board installation.
13. Do periodic inspections to the installation to make sure that all hardware is secure and tight.

**To protect your investment**, wax this product after installing. Regular waxing is recommended to add a protective layer over the finish. Do not use any type of polish or wax that may contain abrasives that could damage the finish.

**For Polished Finishes:** Aluminum polish may be used to polish small scratches and scuffs on the finish. Mild soap may be used also to clean the Running Board.

**For Black Finishes:** Mild soap may be used to clean the Running Board.

### Driver Side Installation Pictured

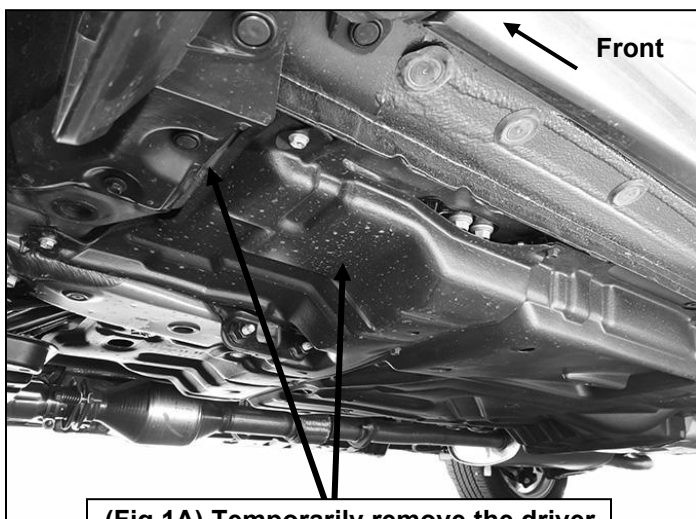

**(Fig 1A) Temporarily remove the driver side front and middle plastic covers**

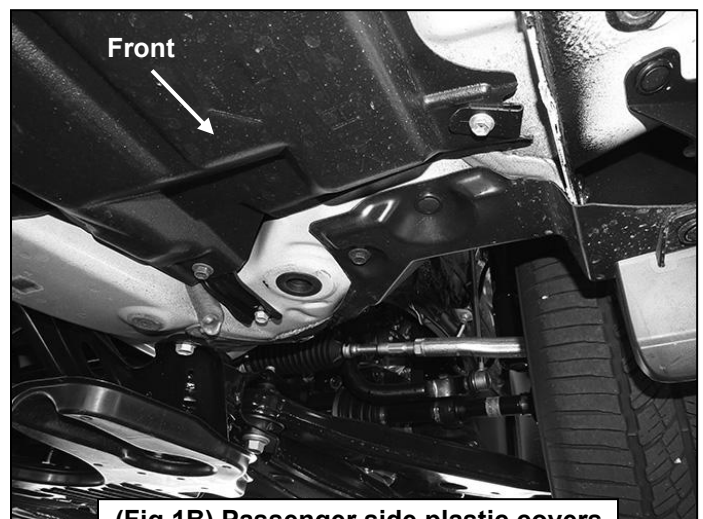

**(Fig 1B) Passenger side plastic covers pictured over mounting location**

### Driver Side Installation Pictured

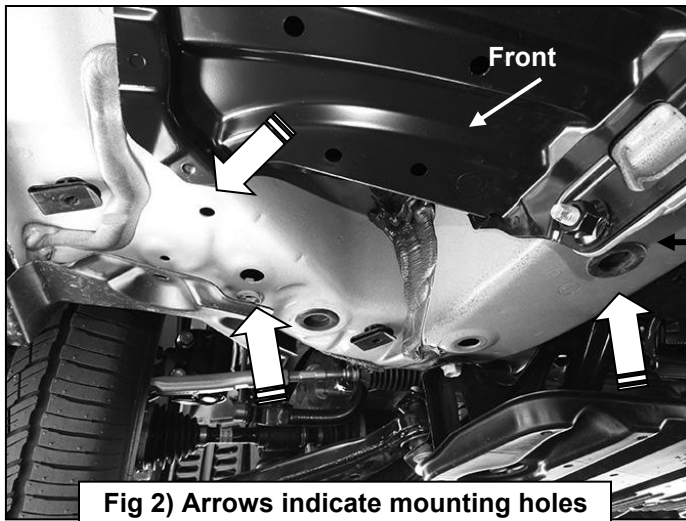

Tie down loop

Remove rubber plug

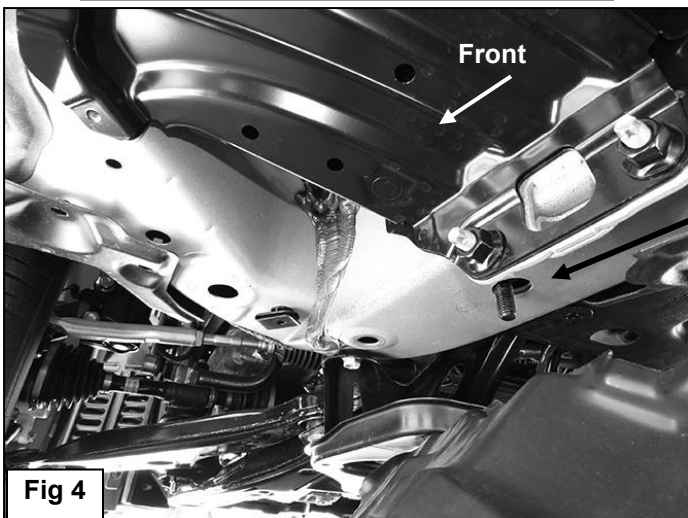
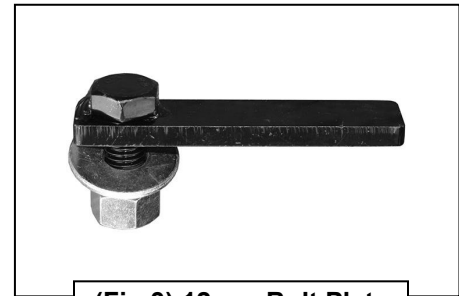

12mm Bolt Plate

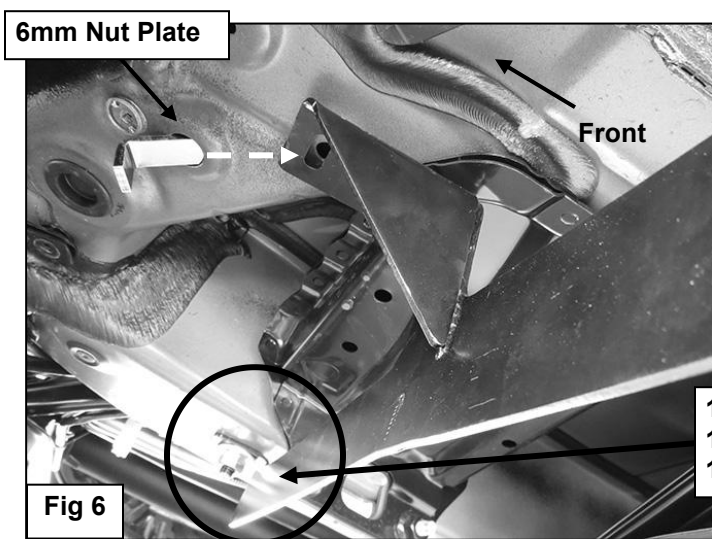
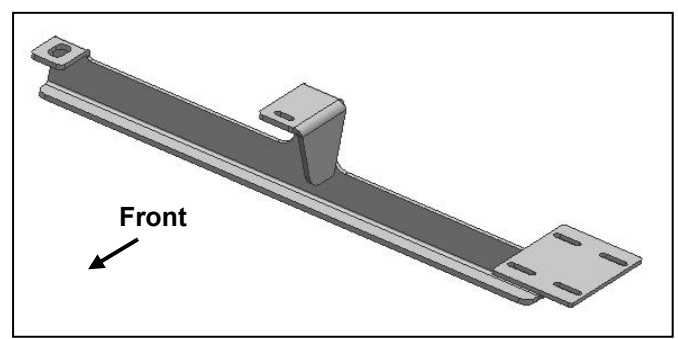

### Driver Side Installation Pictured



(Fig 7) 6mm Threaded Nut Plate

Line up Nut Plate with  
this hole and Bracket

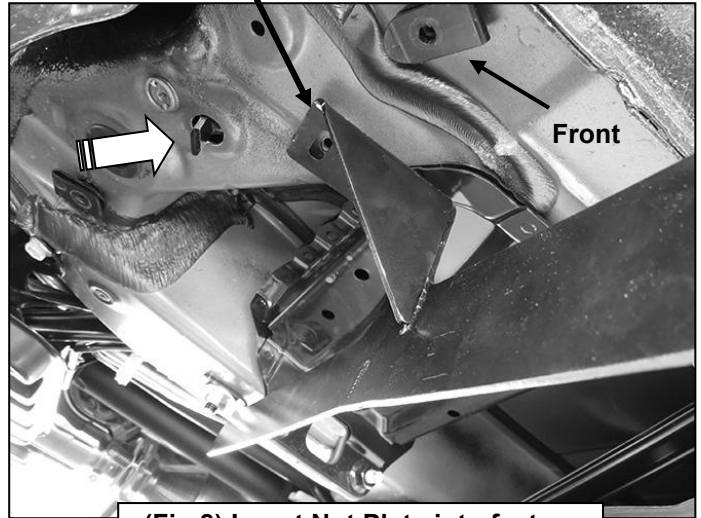

(Fig 8) Insert Nut Plate into factory  
hole (also see Figures 2 & 6)

6mm x 30mm Hex Bolt  
6mm Lock Washer  
6mm Flat Washer



Fig 9

Cut plastic front cover where indicated if  
necessary to clear bent end of 6mm Nut  
Plate as necessary (actual cover may  
differ depending on model and year)

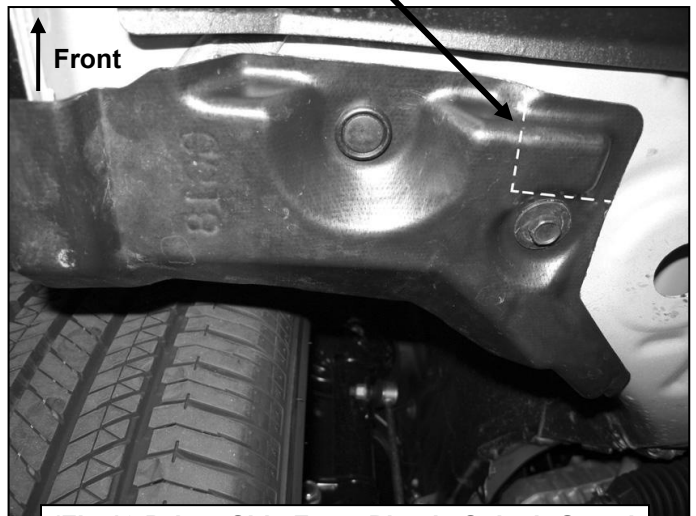

(Fig 10 Driver Side Front Plastic Splash Guard

### Driver Side Installation Pictured

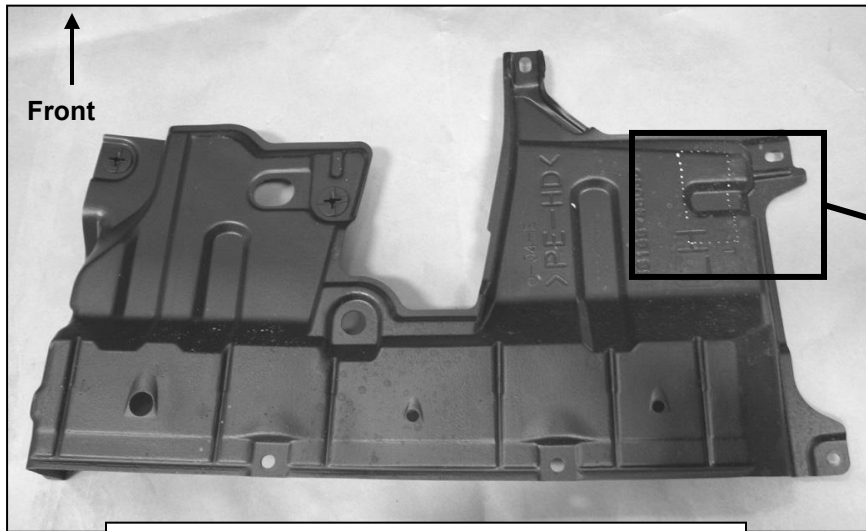

(Fig11) Driver Side Middle Plastic Splash Guard

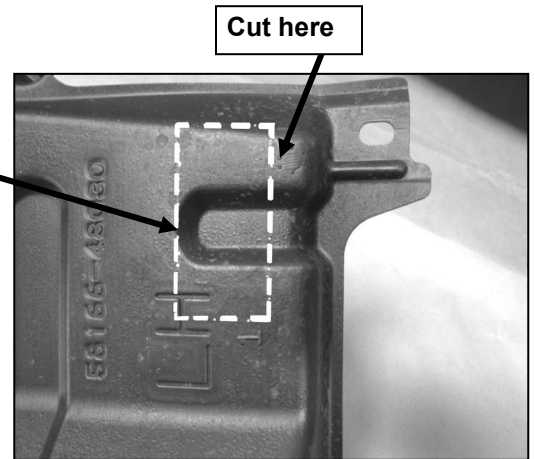

Cut where indicated to clear mounting tab on front Bracket only as necessary (actual cover may differ depending on model and year). Remove front Bracket to reinstall the plastic covers

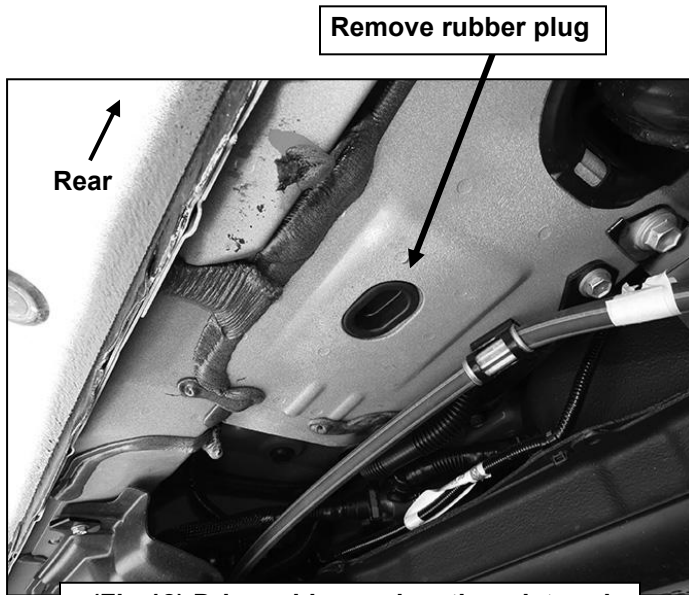

(Fig 12) Driver side rear location pictured



(Fig 13) 10mm T-Block Bolt

### Driver Side Installation Pictured

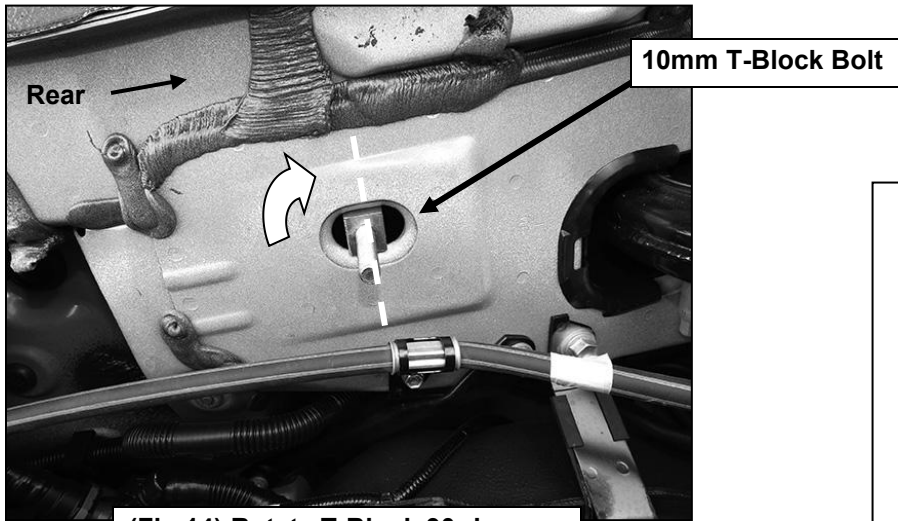

(Fig 14) Rotate T-Block 90-degrees to go across the oval hole

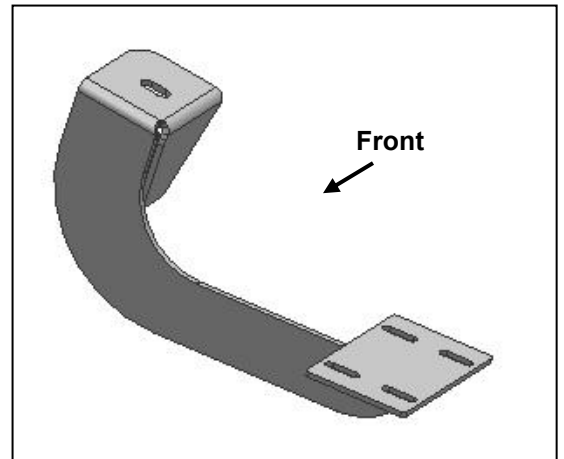

(Fig 15) Driver/left rear Bracket

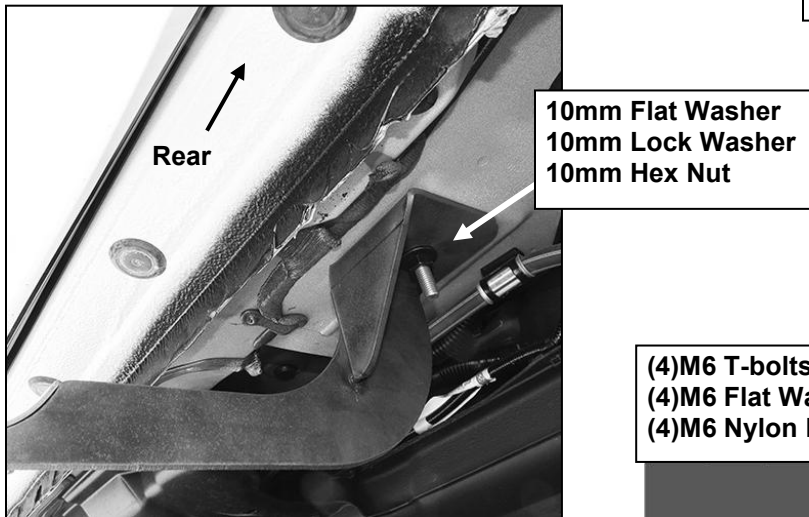
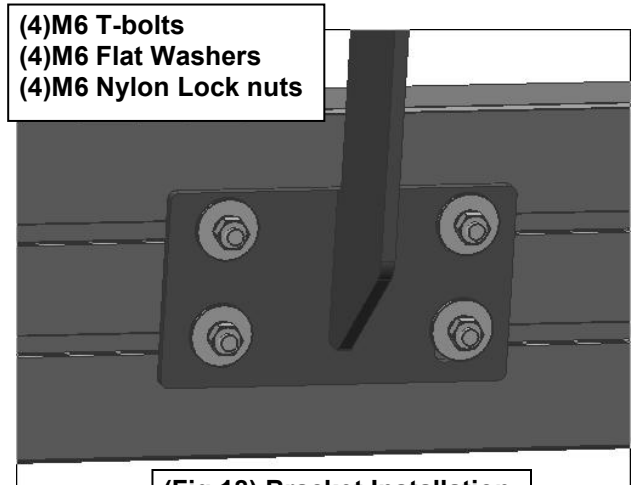

Fig 16



(Fig 18) Bracket Installation



(Fig 17) Slip 6mm T-bolts into the bottom channel