

**PARTS LIST:**

Item	QTY	Description	Item	QTY	Description
#01	2	Running Board(use for left or right)	#14	8	10mm x 30mm OD x 2.5mm Flat Washers
#02	1	Driver/Left Front Mounting Bracket	#15	8	10mm x 20mm OD x 2mm Flat Washers
#03	1	Passenger/Right Front Mounting Bracket	#16	10	10mm Lock Washers
#04	1	Driver/Left Rear Mounting Bracket	#17	10	10mm Hex Nuts
#05	1	Passenger/Right Rear Mounting Bracket	#18	2	6-1.0mm x 25mm Hex Bolts
#06	1	Driver/Left Rear Support Bracket	#19	2	6mm x 18mm OD x 1.6mm Flat Washers
#07	1	Passenger/Right Rear Support Bracket	#20	2	6mm Lock Washers
#08	1	8-1.25mm x 30mm Driver Side Rod Bolt	#21	2	8mm x 24mm OD x 2mm Flat Washers
#09	1	8-1.25mm x 30mm Passenger Side Rod Bolt	#22	2	8mm Lock Washers
#10	2	10-1.50mm x 30mm Rounded Bolt Plates	#23	2	8mm Hex Nuts
#11	2	10-1.50mm x 40mm T-Bolt Plates	#24	8	6-1.0mm x 20mm T-Bolts
#12	2	10-1.50mm x 40mm Bolt Plates	#25	8	6mm x 22mm OD x 2mm Flat Washers
#13	4	10-1.50mm x 30mm Hex Bolts	#26	8	6-1.0mm Lock Nuts

**Front** ↑

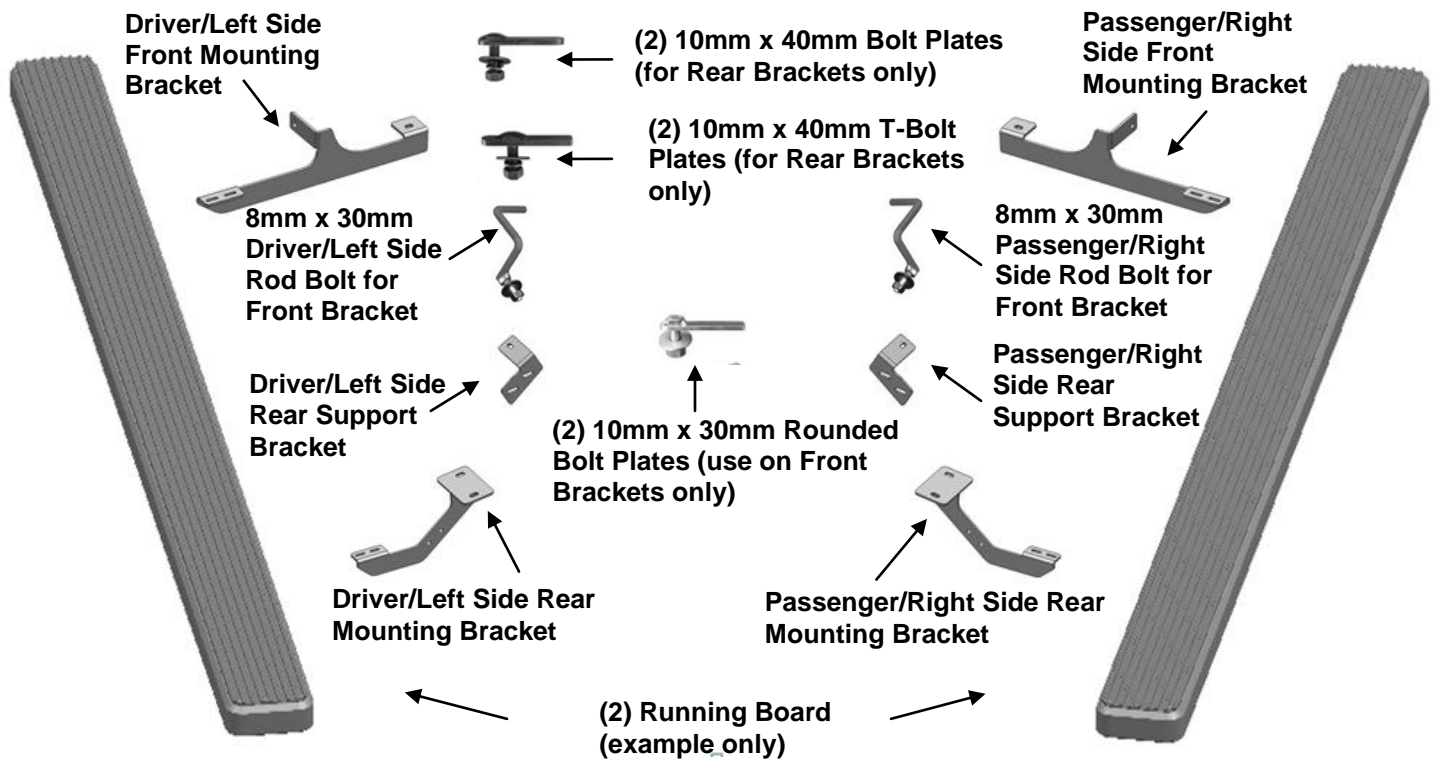

**PROCEDURE:**

1. REMOVE CONTENTS FROM BOX. VERIFY ALL PARTS ARE PRESENT. READ FACTORY BODY BOLT REMOVAL INSTRUCTIONS AND INSTALLATION INSTRUCTIONS CAREFULLY BEFORE STARTING INSTALLATION.
2. Starting at the front, driver side of the vehicle, locate the round hole in the backside of the body panel, **(Figure 1)**. **NOTE:** The hole will be covered by sealing tape and undercoating. Use a small screwdriver to locate and remove the tape.

3. Remove the rubber plug covering the hole in the bottom of the body panel next to the pinch weld, **(Figure 2)**. Insert the driver side 8mm x 30mm Rod Bolt into the large hole in the bottom of the body panel and out the smaller hole in the backside of the body panel identified in Step 2, **(Figure 3)**.
4. Next, locate the oval slot in the bottom of the inner frame channel, **(Figure 4A)**. Insert (1) 10mm x 30mm Rounded Bolt Plate into the frame channel, **(Figure 4B)**. Select the driver side Front Frame Bracket. Hang the bracket from the 8mm Rod Bolt with (1) 8mm Flat Washer, (1) 8mm Lock Washer and (1) 8mm Hex Nut, **(Figure 3)**. Secure the Bracket to the Rounded Bolt Plate with the supplied (1) 10mm x 30mm x 2.5mm Large Flat Washer, (1) 10mm Lock Washer and (1) 10mm Hex Nut, **(Figure 5)**. Snug but do not tighten hardware at this time.
5. Moving toward the rear of the vehicle, remove the factory 6mm hex bolt securing the plastic cover to the floor channel, **(Figure 6)**. Remove the rubber plugs covering the round and oval holes in the floor panel pictured in **Figure 6**. Insert (1) 10mm Bolt Plate into the round opening. Insert (1) 10mm T-Bolt Plate into the oval opening, **(Figure 7)**. **IMPORTANT**: Rotate T-Bolt Plate 90-degrees to the direction of the oval opening.
6. Position the driver side Rear Frame Bracket up to the vehicle and partially attach the Bracket to the (2) Bolt Plates inserted into the body panel. Secure using the included (2) 10mm x 30mm Large OD Flat Washers, (2) 10mm Lock Washers and (2) 10mm Hex Nuts, **(Figure 8)**. Snug but do not tighten hardware at this time.
7. Select the Passenger Side Rear Support Bracket. Hold the Bracket up to the threaded hole in the floor channel and insert the included (1) 6mm x 25mm Hex Bolt with (1) 6mm Lock Washer and (1) 6mm Flat Washer through the plastic cover, the Support Bracket and into the floor channel, **(Figure 9)**. Do not tighten hardware at this time.
8. Line the mounting surface on the Support Bracket with the (2) holes in the Rear Mounting Bracket. Bolt the Support Bracket to the Mounting Bracket with the included (2) 10mm x 30mm Hex Bolts, (4) 10mm x 20mm STD OD Flat Washers, (2) 10mm Lock Washers and (2) 10mm Hex Nuts, **(Figure 10)**. Snug but do not tighten hardware at this time.
9. Select a Running Board. Slip (4)6mm T-bolts into each bottom channel **(Figure 11)**. Carefully position the Running Board onto the (2) Mounting Brackets. **IMPORTANT**: Do not slide, (front to back), the Running Board on the Brackets or damage to the finish may result. Attach the Running Board to each Mounting Brackets with (2) 6mm T-bolts, (2)6mm flat washers and (2)6mm lock nuts **(Figures 12)**. Do not tighten at this time.
10. Level and adjust Running Board properly and tighten all hardware.
11. Repeat **Steps 2 – 10** for passenger side Running Board installation.
12. Do periodic inspections to the installation to make sure that all hardware is secure and tight

**To protect your investment**, wax this product after installing. Regular waxing is recommended to add a protective layer over the finish. Do not use any type of polish or wax that may contain abrasives that could damage the finish.

**For Polished Finishes:** Aluminum polish may be used to polish small scratches and scuffs on the finish. Mild soap may be used also to clean the Running Board.

**For Black Finishes:** Mild soap may be used to clean the Running Board.

### Driver Side Installation Pictured

Use a small screwdriver to remove sealant tape covering small 8mm hole in backside of body panel

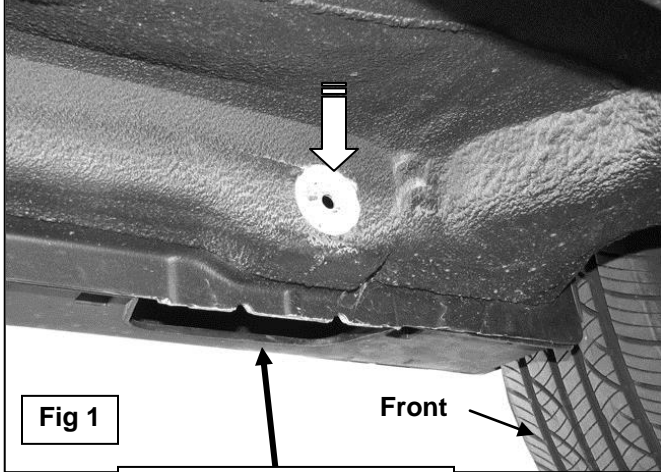

Remove the rubber plug

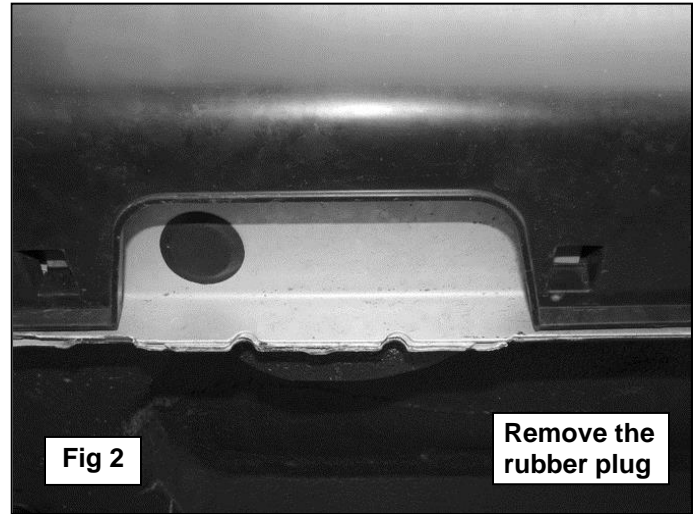

8mm Rod Bolt  
8mm Flat Washer  
8mm Lock Washer  
8mm Hex Nut

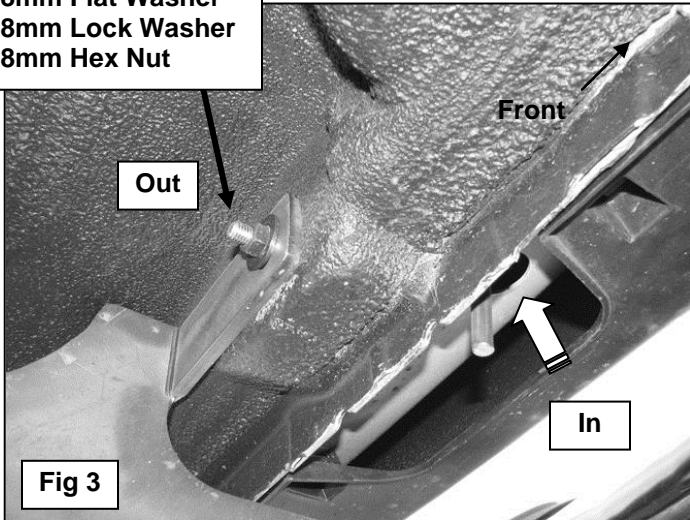

Insert 8mm x 30mm Rod Bolt into large round hole in bottom of body panel and out smaller hole in backside of body panel, (Pictured from below vehicle)

10mm x 30mm  
Rounded Bolt Plate

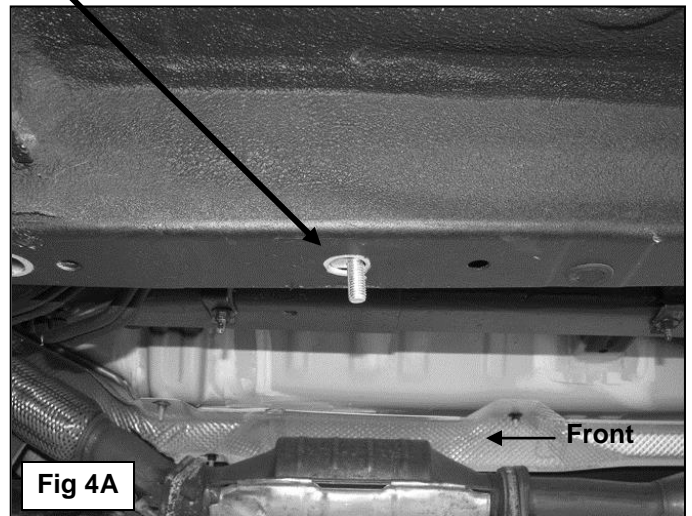
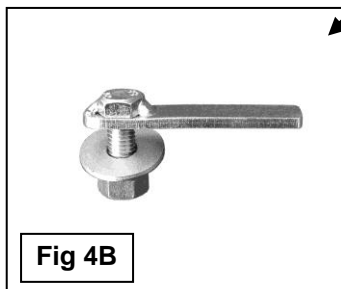

10mm x 30mm  
Rounded Bolt Plate  
10mm x 30mm Large  
OD Flat Washer  
10mm Lock Washer  
10mm Hex Nut

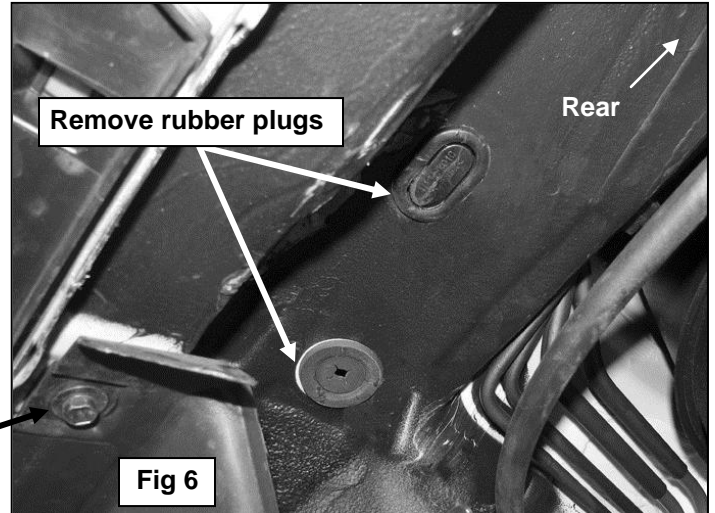
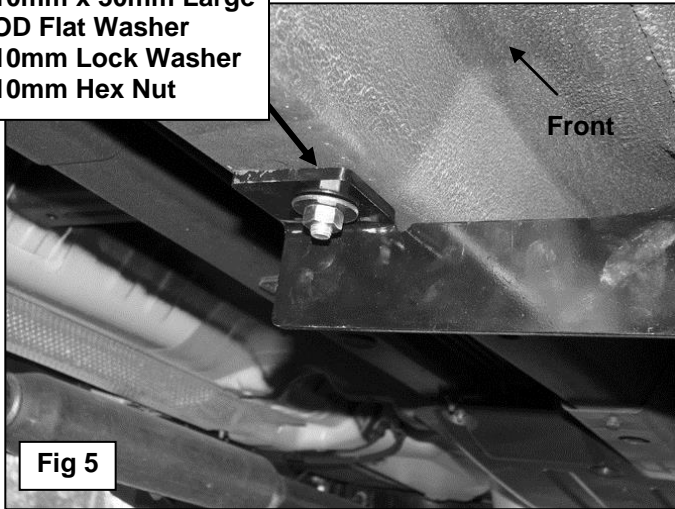

Remove 6mm hex  
bolt holding plastic  
cover in place

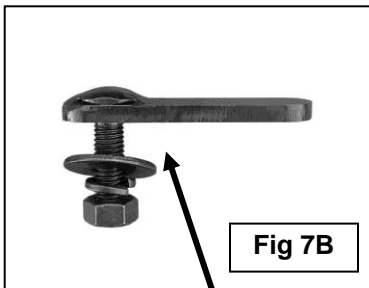

10mm x 40mm  
Bolt Plate

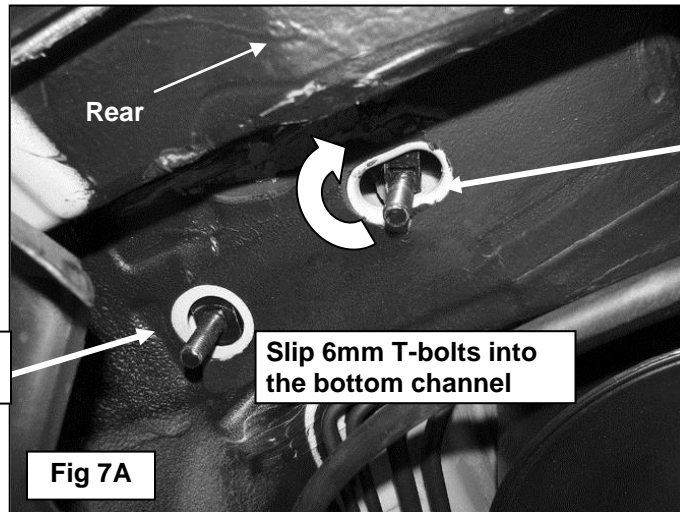

10mm x 40mm  
T-Bolt Plate  
Insert T-Bolt Plate  
into opening and  
rotate 90-degrees  
to direction of slot

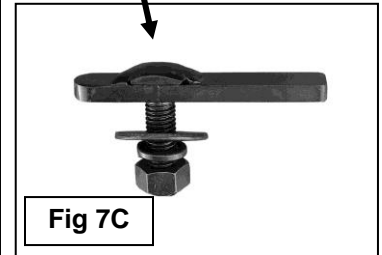

(2) 10mm x 30mm Large  
OD Flat Washers  
(2) 10mm Lock Washers  
(2) 10mm Hex Nuts

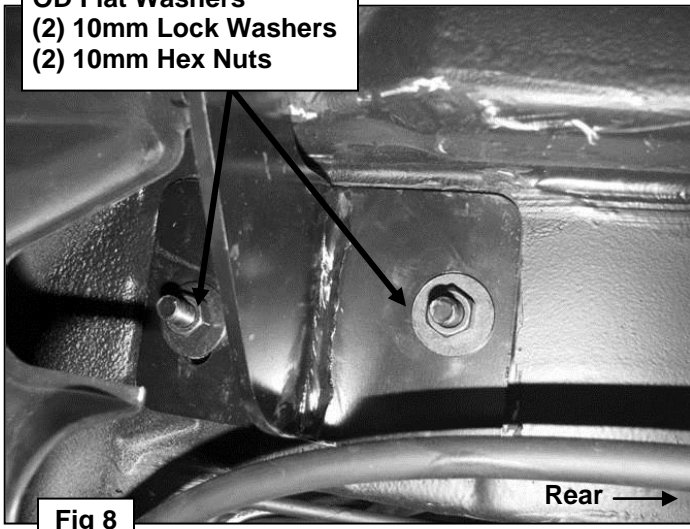

6mm x 25mm Hex Bolt  
6mm Lock Washer  
6mm Flat Washer

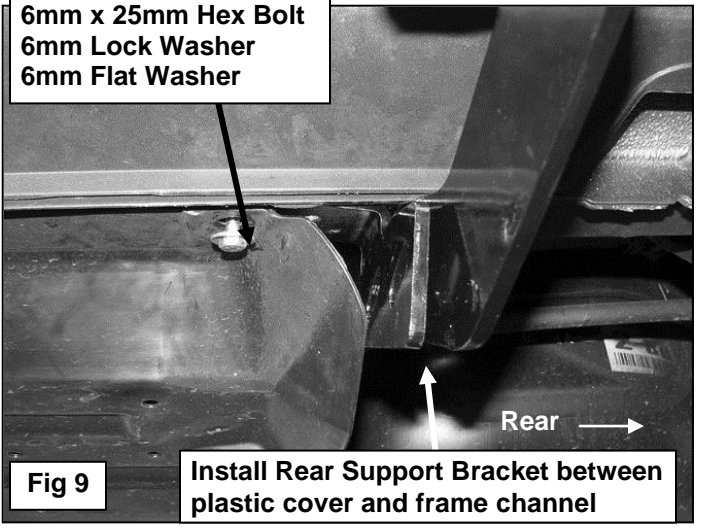

- (2) 10mm Hex Bolts
- (2) 10mm Lock Washers
- (4) 10mm x 20mm OD STD Flat Washers
- (2) 10mm Hex Nuts

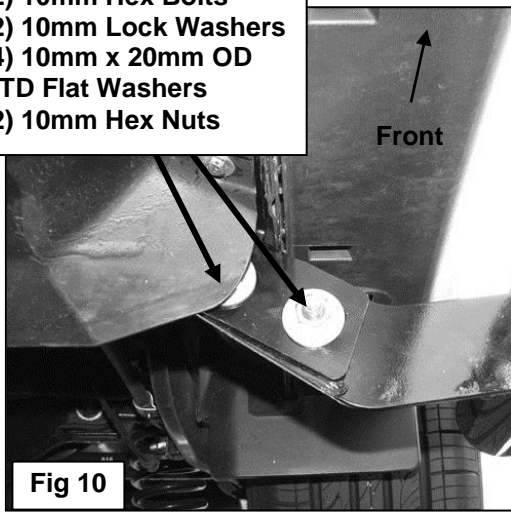

Fig 10

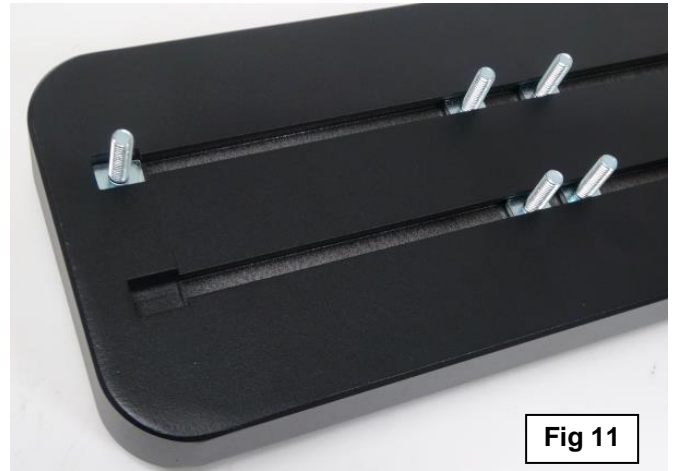
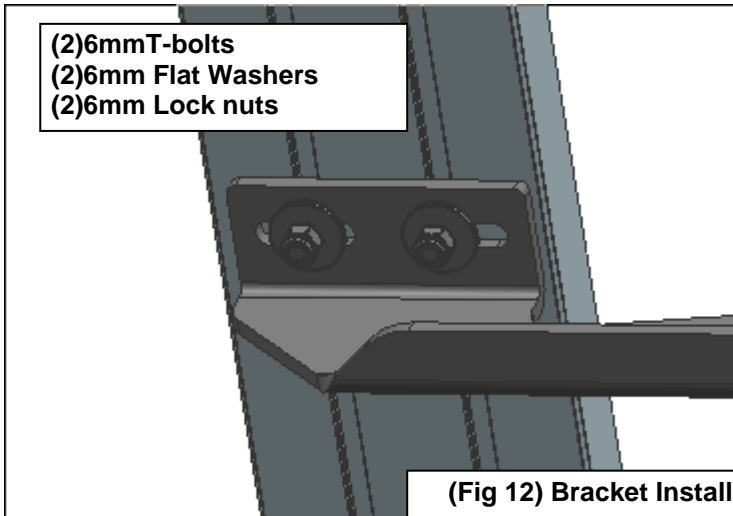

Fig 11

- (2)6mm T-bolts
- (2)6mm Flat Washers
- (2)6mm Lock nuts



(Fig 12) Bracket Installation