

Installation Instruction

Part#:IB11DBG2A

REV: 20140101

Application: For 2011KIA SORRENTO

Item	Part Name	QTY	Item	Part Name	QTY
1	Driver Sidebar	1	11	12mm Hex Nuts	6
2	Passenger Sidebar	1	12	10-1.25mm x 35mm Fine Thread Hex Bolts	4
3	Driver/Left Front Mounting Bracket	1	13	10-1.50mm x 35mm Hex Bolts	4
4	Passenger/Right Front Mounting Bracket	1	14	10mm x 30mm x 2.5mm Flat Washers	12
5	Driver/Left Rear Mounting Bracket	1	15	10mm Lock Washers	8
6	Support Brackets	4	16	10-1.50mm Hex Nuts	4
7	12-1.75mm X 40mm Special Short Bolt Plates	4	17	M6X1mm Nylon Lock Nuts	16
8	12-1.75mm X 40mm Special Long Bolt Plates	2	18	M6X1-25mm Square Hex Bolt	16
9	12mm x 37mm x 3mm Flat Washers	6	19	M6 Flat Washers	16
10	12mm Lock Washers	6			



Passenger Side Front Mounting Bracket



Driver Side Front Mounting Bracket



Passenger Side Rear Mounting Bracket



Driver Side Rear Mounting Bracket



(4) Support Bracket

Step	Installation Instruction
-------------	---------------------------------

The instruction here is for your reference only. We strongly recommend the professional installer for best result. We are not responsible for any damage caused by the installation. Thank you for choosing our product!

Installation Instruction

Part#:IB11DBG2A

REV: 20140101

Application: For 2011KIA SORRENTO

1	<u>CHECK PART LIST AND MAKE SURE ALL COMPONENTS ARE PRESENT. READ FOLLOWING INSTRUCTIONS CAREFULLY BEFORE STARTING INSTALLATION. DRILLING REQUIRED.</u>
2	Starting at the front, passenger side of the vehicle, locate and remove the rubber plug in the body well located next to the outer pinch weld, (Figure 1) . Insert (1) 12mm x 40mm Short Bolt Plate into the outer hole in the body and center it in the hole, (Figure 2) . Select (1) Support Bracket and hang the Bracket from the Bolt Plate with (1) 12mm Lock Washer, (1) 12mm Flat Washer and (1) 12mm Hex Nut, (Figure 3) . Do not tighten hardware at this time.
3	Remove the two 10-1.25mm fine thread factory hex bolts located on the bottom of the frame rail, (Figure 4) . Select the passenger side Front Mounting Bracket. Hang the Bracket from the two threaded holes in the inner frame rail using the supplied (2) 10-1.25mm x 35mm Special Fine Thread Hex Bolts , (2) 10mm Lock Washers and (2) 10mm Flat Washers, (Figure 5) . Line up the outer mounting hole in the Mounting Bracket with the Support Bracket and bolt together with (1) 10-1.5mm x 35mm Coarse Thread Hex Bolt, (2) 10mm Flat Washers, (1) 10mm Lock Washer and (1) 10mm Hex Nut, (Figure 6) . Snug but do not tighten hardware at this time.
4	Move toward the rear of the vehicle. Remove the round rubber plug on the outer body panel next to the pinch weld and repeat Step 2 for Support Bracket installation, (Figure 7 & 8) .
5	Remove the oval rubber plug, (if equipped), located on the bottom of the inner frame rail. Insert the(1)12mm x 40mm Long Bolt Plate (long leg) into the oval hole and center it over the slot, (Figure 9) .
6	Position the passenger side Rear Frame Bracket up to the vehicle and partially attach the Bracket to the 12mm Bolt Plate inserted into the oval hole in the frame rail, (Figure 10) . Secure the Bracket to the Bolt Plate with the included (4)M6 Square Hex Bolt (4)M6 Nylon Lock Nuts (4)M6 Flat Washers. Line up the outer mounting hole in the Mounting Bracket with the Support Bracket and bolt together with (1) 10-1.5mm x 35mm Coarse Thread Hex Bolt, (2) 10mm Flat Washers, (1) 10mm Lock Washer and (1) 10mm Hex Nut, (Figure 11) . Snug but do not tighten hardware at this time.
7	Position the passenger Sidebar onto the Mounting Brackets and attach it using the included M6 Square Hex Bolt M6 Nylon Lock Nuts and M6 Flat Washers, (Figure 11)
8	Level and adjust Sidebar, then tighten all hardware at this time.
9	Repeat steps 2 - 8 for driver Sidebar installation.
10	DO periodic inspections of the installation to make sure all hardware is secure and tight.

TO Protect your investment, wax this product after installing. Regular waxing is recommended to add a protective layer over the finish. Do not use any type of polish or wax that may contain abrasives that could damage the finish.

For stainless steel: Aluminum polish may be used to polish small scratches and scuffs on the finish. Mild soap may be used also to clean the Sidebar.

For gloss black finishes: Mild soap may be used also to clean the Sidebar.

The instruction here is for your reference only. We strongly recommend the professional installer for best result. We are not responsible for any damage caused by the installation. Thank you for choosing our product!

Installation Instruction

Part#:IB11DBG2A

REV: 20140101

Application: For 2011KIA SORRENTO

(Passenger Sidebar Installation Shown)

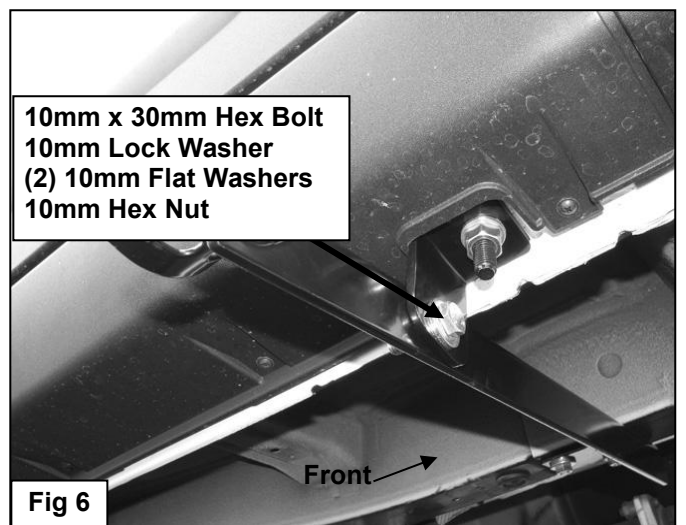
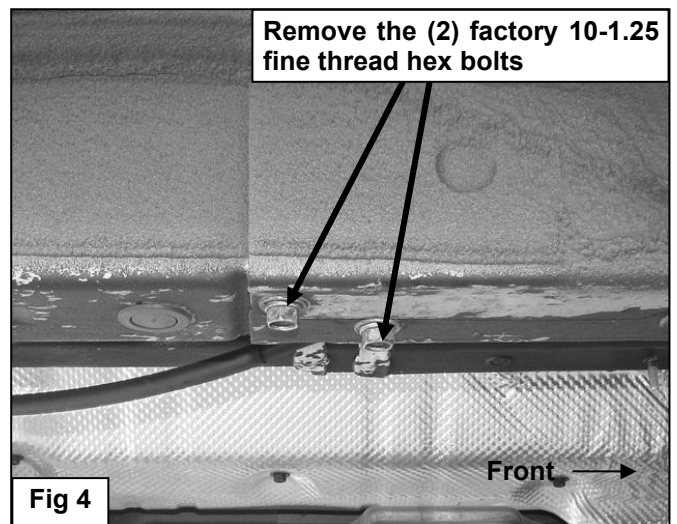
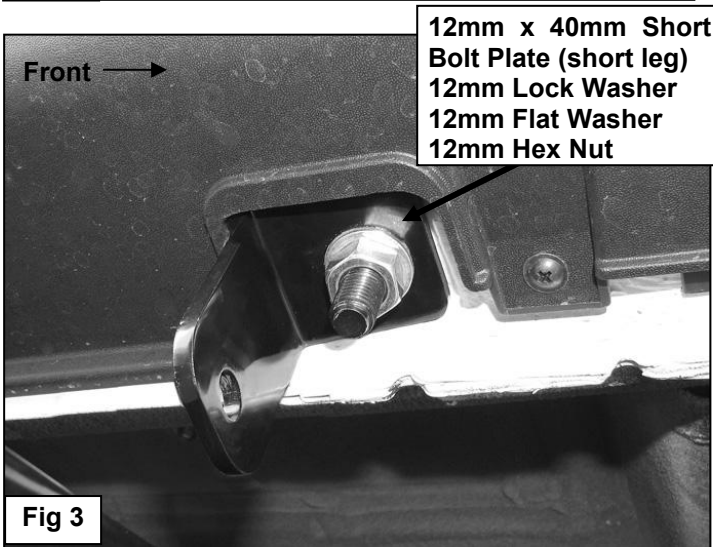
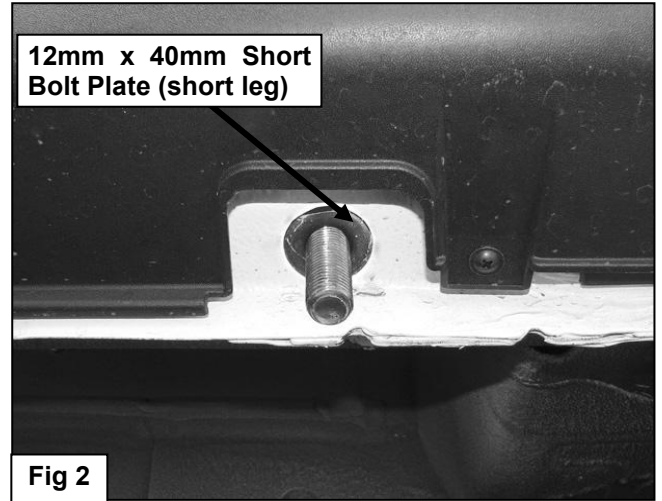
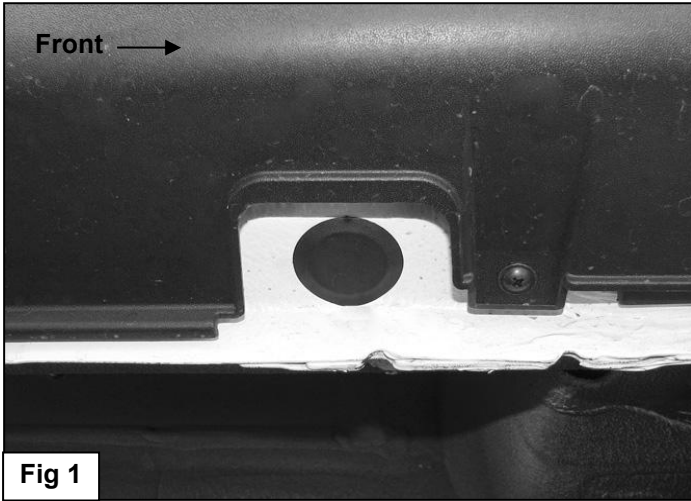

The instruction here is for your reference only. We strongly recommend the professional installer for best result. We are not responsible for any damage caused by the installation. Thank you for choosing our product!

Installation Instruction

Part#:IB11DBG2A

REV: 20140101

Application: For 2011KIA SORRENTO

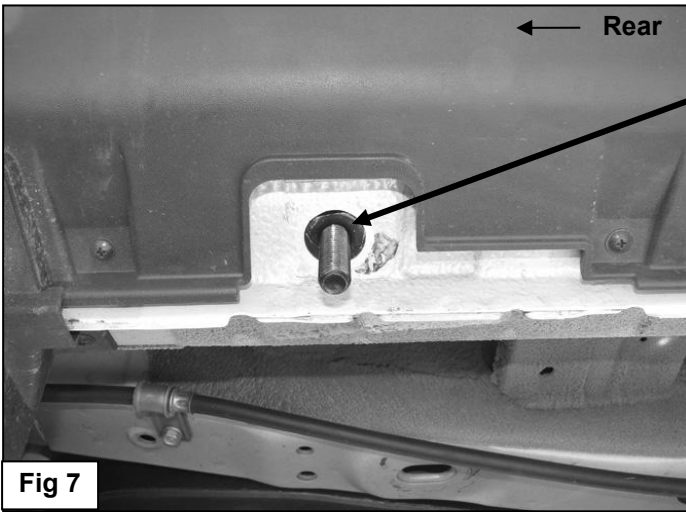

12mm x 40mm Short Bolt Plate (short leg). Passenger side rear installation pictured

12mm x 40mm Short Bolt Plate (short leg)
12mm Lock Washer
12mm Flat Washer
12mm Hex Nut

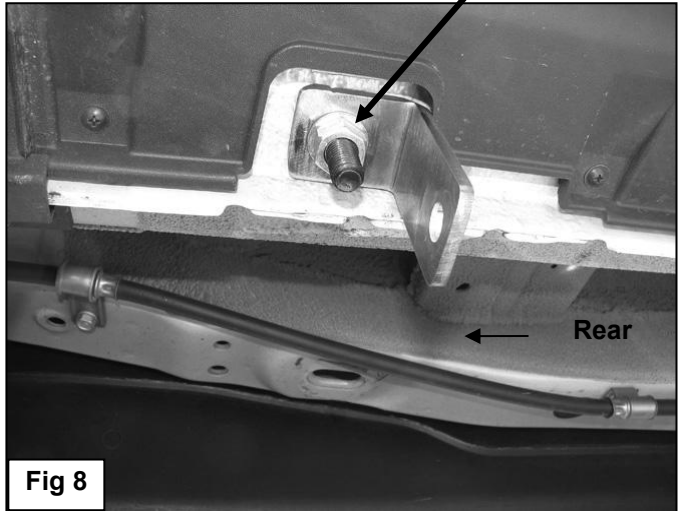
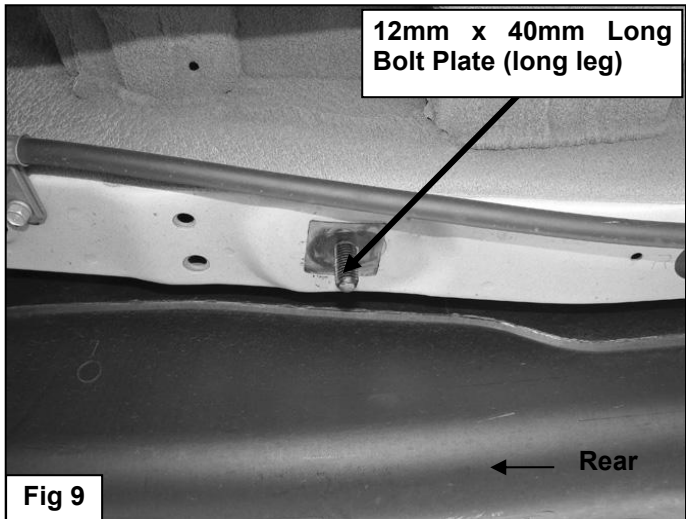
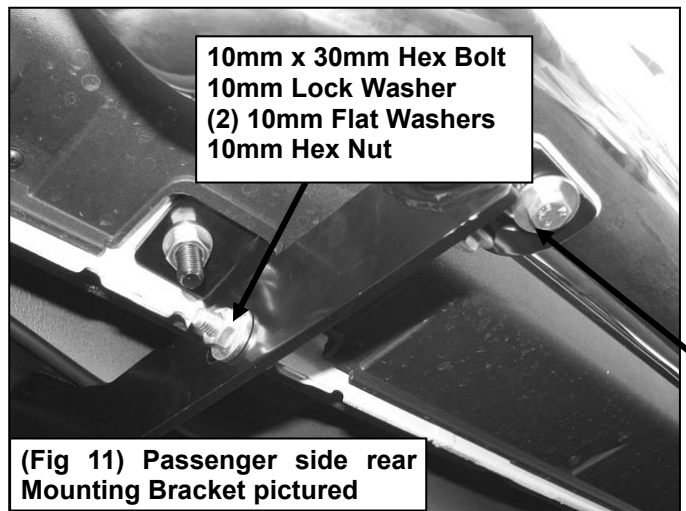

Fig 8



12mm Lock Washer
12mm Flat Washer
12mm Hex Nut



10mm x 30mm Hex Bolt
10mm Lock Washer
(2) 10mm Flat Washers
10mm Hex Nut

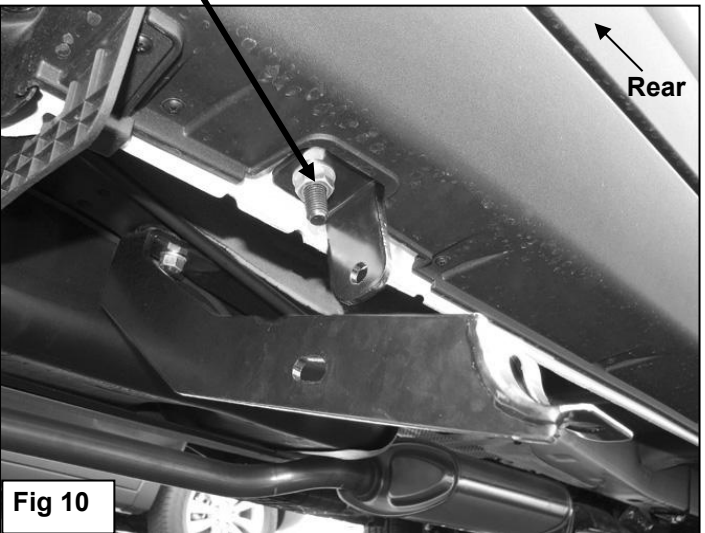

Fig 10

M6 Square Hex Bolt
M6 Nylon Lock Nuts
M6 Flat Washers

The instruction here is for your reference only. We strongly recommend the professional installer for best result. We are not responsible for any damage caused by the installation. Thank you for choosing our product!