

# Installation Instructions for IB10EJH4

by APS Auto Parts Specialist Inc.

Application: FOR 1987-2006 Jeep Wrangler  
Estimated Time: 1 to 2 hours



Disclaimer: Instructions intended for persons aged 18+ please do not attempt without adult supervision. Instructions are not intended to replace professional installation. Damage from improper installation, misuse or modification to the product voids the manufacturer's warranty.

**PARTS LIST:**

Item	QTY	Description	Item	QTY	Description
#1	2	Running Board(use for right or left)	#8	8	M12 Flat Washers
#2	4	Frame Mounting Brackets (DFM)	#9	4	M12 Lock Washers
#3	1	Driver//Left Front Bracket (DFB)	#10	4	M12 Hex Nuts
#4	1	Driver/Left Rear Bracket (DRB)	#11	16	M6 x 20mm T-Bolts
#5	1	Passenger/Right Front Bracket (PFB)	#12	16	M6 Flat Washers
#6	1	Passenger/Right Rear Bracket (PRB)	#13	16	M6 Nylon Lock Nuts
#7	4	M12x35mm Hex bolts			

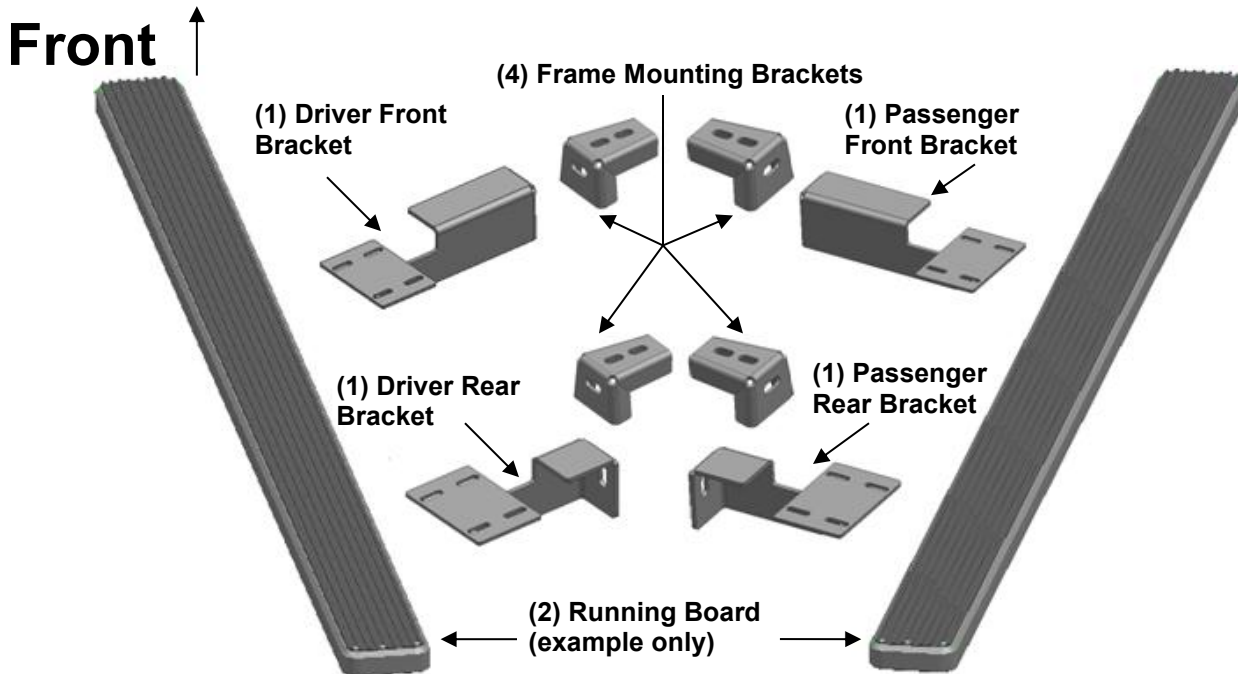

**PROCEDURE:**

1. REMOVE CONTENTS FROM BOX. VERIFY ALL PARTS ARE PRESENT. READ INSTRUCTIONS CAREFULLY. FACTORY INSTALLED OR AFTERMARKET "ROCK RAILS," SIDE STEPS OR RUNNING BOARDS MUST BE REMOVED.
2. Start installation toward the front of the driver side of the vehicle. Remove the factory body mount bolt(Figures 1). Select (1) Frame Mounting Bracket. Insert the factory body mount bolt through the appropriate slot, the rubber bushing and back into the vehicle. **NOTE:** Do not remove the rubber bushing. The Mounting Bracket will install over the rubber bushing. **IMPORTANT:** The Brackets are equipped with (2) mounting slots. Determine correct model year for proper installation(Figures 2-3):
  - a. **1987 - 1995 Vehicles:** Use the inner slot. Do not tighten hardware at this time.
  - b. **1997 - 2006 Vehicles:** Use the outer slot closer to the bend in the Bracket. Do not tighten hardware at this time.
3. Select the driver front bracket, attach to the frame mounting bracket with (1)12mmx35 Hex bolt,(2)12mm flat washers,(1)12mm lock washer and (1)12mm hex nut(Figures 4).
4. Repeat **Step 2-3** for rear Mounting Bracket installation.
5. Select a Running Board. Slip(8)M6 T-bolts into each bottom channel(Figure 5). Carefully position the Running Board onto the (2) Mounting Brackets. **IMPORTANT:** Do not slide, (front to back), the Running Board on the Brackets or damage to the finish may result. Attach the Running Board to the Mounting Brackets with(4) M6 T-bolts,(4)M6 flat washers and (4)M6 nylon lock nuts (Figures 6). Do not tighten at this time.
6. Level and adjust the Running Board and Brackets and tighten all hardware.
7. Repeat **Steps 2 - 6** for Passenger Running board installation.

8. Do periodic inspections to the installation to make sure that all hardware is secure and tight.

**To protect your investment**, wax this product after installing. Regular waxing is recommended to add a protective layer over the finish. Do not use any type of polish or wax that may contain abrasives that could damage the finish.

**For Polished Finishes:** Aluminum polish may be used to polish small scratches and scuffs on the finish. Mild soap may be used also to clean the Running Board.

**For Black Finishes:** Mild soap may be used to clean the Running Board.

### Driver Side Installation Pictured



(Fig 1) Remove factory body mount bolt

1987 - 1995 Vehicles:  
Use the inner slot

1997 - 2006 Vehicles:  
Use the outer slot  
closer to the bend in  
the Bracket



Fig 2

Re-use the factory hex bolt to  
attach the Bracket to rubber  
bushing and body mount

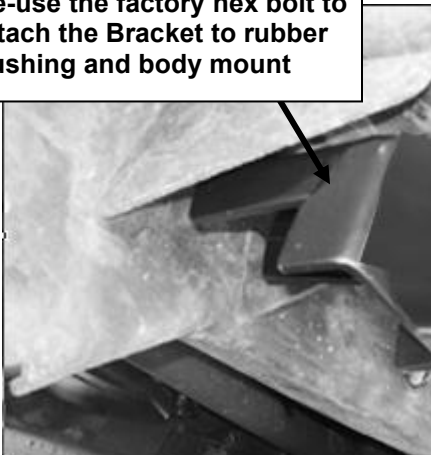

(Fig 3)Frame Bracket installation pictured

- (1) M12 x 35mm Hex Bolts
- (2) M12 Lock Washers
- (1) M12 Flat Washers
- (1) M12 Hex Nuts

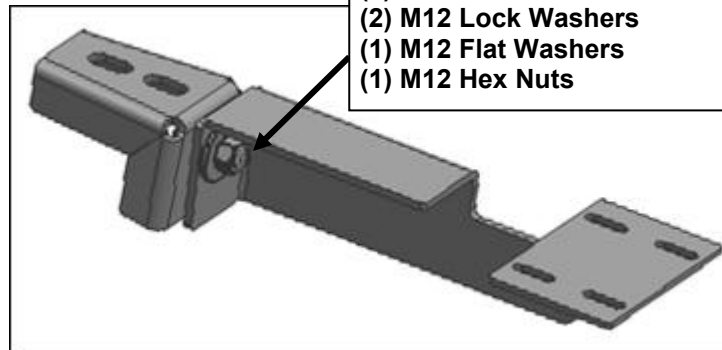

(Fig 4)Driver Front Bracket installation pictured

- (4)M6 T-bolts
- (4)M6 Flat Washers
- (4)M6 Nylon Lock nuts



(Fig 5) Slip 6mm T-bolts  
into the bottom channel

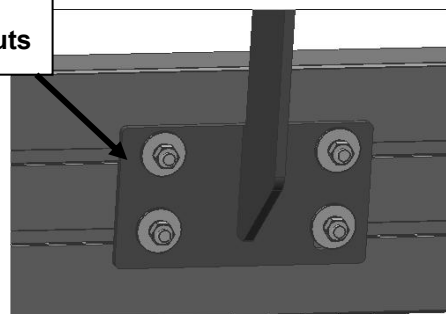

(Fig 6)Running Board Installation