

Installation Instruction

Part#: IB10DAI2A

REV: 20150301

Application: For JEEP PATRIOT 07 - 14

Item	Part Name	QTY	Item	Part Name	QTY
1	Driver/ Left Sidebar	1	15	12mm x 37 mm OD x 3mm Flat Washers	14
2	Passenger/ Right Sidebar	1	16	12 - 1.75mm Hex Nuts	10
3	Driver/Left Front Mounting Bracket (LF)	1	17	10-1.5mm x 35mm Hex Bolts	2
4	Passenger/Right Front Mounting Bracket (RF)	1	18	10mm Lock Washers	2
5	Driver/Left Front Frame Bracket (LFF)	1	19	10mm x 30 mm OD x 2.5mm Flat Washers	4
6	Passenger/Right Frame Bracket (RFF)	1	20	10mm Hex Nuts	2
7	Driver/Left Front Front Support Bracket (LFS)	1	21	M8-1.25x35mm Hex Bolts	2
8	Passenger/Right Front Front Support Bracket (RFS)	1	22	8mm x 24 mm OD x 2mm Flat Washers	4
9	Driver/Left Rear Mounting Bracket (LR)	1	23	8mm Lock Washers	2
10	Passenger/Right Rear Mounting Bracket (RR)	1	24	8mm Hex Nuts	2
11	12-1.75mm x 35mm Bolt Plates	4	25	M6 Square Hex Bolt	16
12	12-1.75mm x 70mm Long Bolt Plates	2	26	M6 Flat Washers	16
13	12-1.75mm x 35mm Hex Bolts	4	27	M6 Nylon Lock Nuts	16
14	12mm Lock Washers	10			

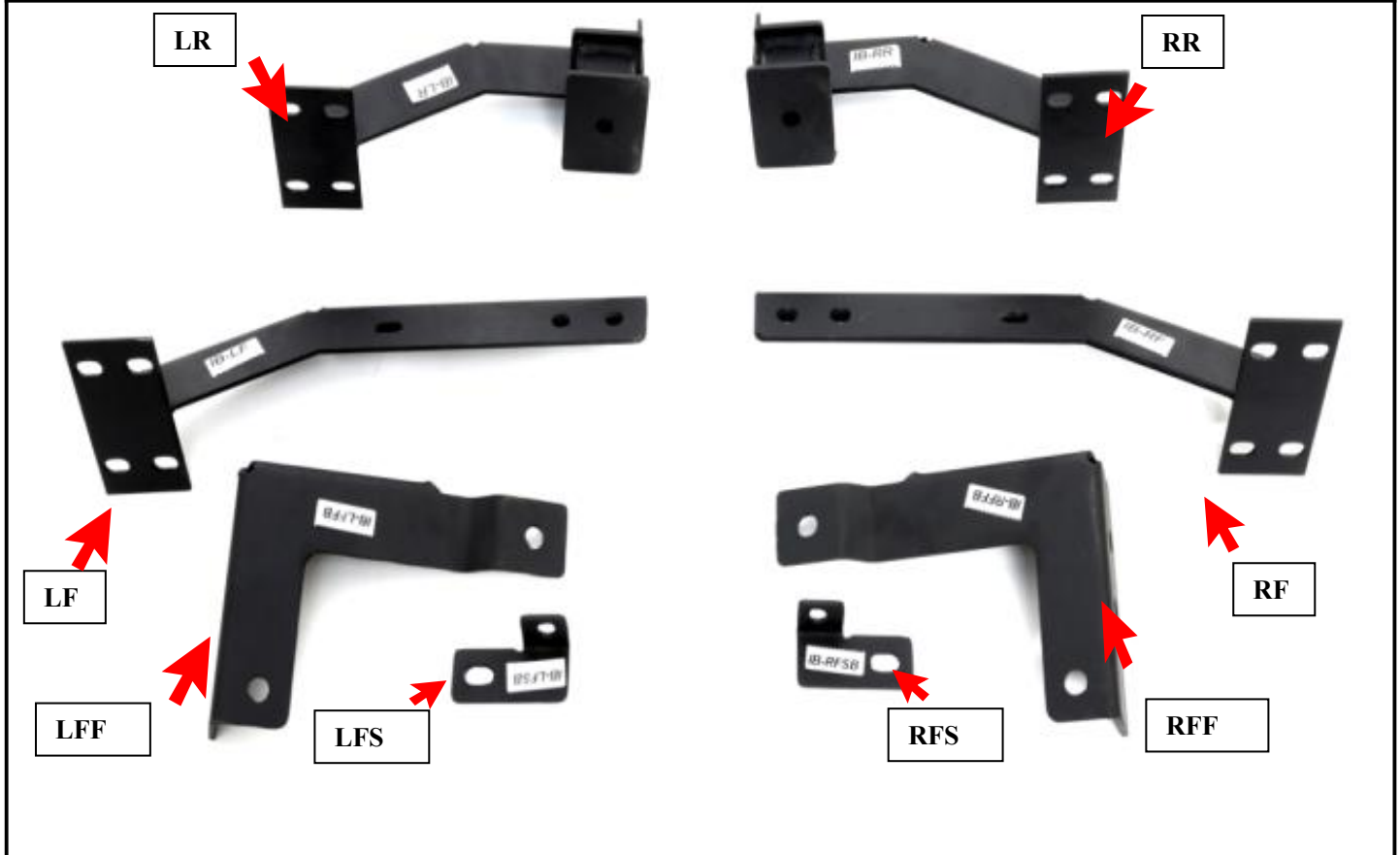

The instruction here is for your reference only. We strongly recommend the professional installer for best result. We are not responsible for any damage caused by the installation. Thank you for choosing our product!

Installation Instruction

Part#: IB10DAI2A

REV: 20150301

Application: For JEEP PATRIOT 07 - 14

Step	Installation Instruction
PROCEDURE: REMOVE CONTENTS FROM BOX. VERIFY ALL PARTS ARE PRESENT. READ INSTRUCTIONS CAREFULLY BEFORE STARTING INSTALLATION. DRILLING AND CUTTING IS REQUIRED. ASSISTANCE IS RECOMMENDED.	
1	Starting at the driver side front of the vehicle, locate the three factory holes, (1 round and 2 oval holes), in the bottom of the left front floor panel, (Figure 1) . Insert (1) 12mm x 35mm Bolt Plate into the smaller, (inner), oval hole and feed the threaded end back out through the larger, (outer), oval hole, (Figures 2A & 2B) . Next, insert (1) 12mm Bolt Plate into the oval hole in the bottom of the inner frame channel, (Figure 3) .
2	Attach the driver side front Frame Mounting Bracket to the (2) Bolt Plates Bracket to the included (2) 12mm Flat Washers, (2) 12mm Lock Washers and (2) 12mm Hex Nuts, (Figure 4) . Do not tighten hardware at this time.
3	Select the driver/left front Sidebar Mounting Bracket. Bolt the Mounting Bracket to the back of the Frame Bracket with the included (2) 12mm Hex Bolts, (4) 12mm Hex Nuts, (2) 12mm Lock Washers and (2) 12mm Hex Nuts, (Figure 5B) . Do not tighten at this time.
4	Next, select the driver side Front Support Bracket, (Figure 5A) . Attach the Support Bracket to the front side of the Mounting Bracket with (1) 10mm Hex Bolt, (2) 10mm Flat Washers, (1) 10mm Lock Washer and (1) 10mm Hex Nut, (Figure 5B) . Leave completely loose at this time.
5	Move along the side of the vehicle toward the rear. Locate the large oval slot in the floor panel insert (1) 12mm x 60mm Long Bolt Plate into the slot, (Figure 6A) . NOTE: rotate the Bolt Plate so that the plate is across, not inline with the oval hole, (Figure 6B) .
6	Attach the driver side rear Mounting Bracket to the Long Bolt Plate with (1) 12mm Flat Washer, (1) 12mm Lock Washer and (1) 12mm Hex Nut (Figure 7) .
7	With the sidebar Bracket hardware loose, pull the Brackets outward away from the vehicle for proper clearance.
8	Select the driver/left Sidebar and carefully place it onto the (2) Mounting Brackets. Attach the Sidebar to the Brackets with the included (4) M6 Square Hex Bolt, (4) M6 Flat Washers, and (4) M6 Nylon Lock Nuts (Figure 7 - 9) . Leave loose at this time.
9	Line up the Front Support Bracket with the back of the pinch weld, (Figure 8) . Push the Support Bracket up as high as possible to where the pinch weld meets the floor panel. Snug but do not fully tighten hardware.
10	Check the Sidebar for level. Once properly aligned and adjusted, tighten all hardware. IMPORTANT: If the Support Bracket is too low and close to the edge of the pinch weld, loosen the Support Bracket and front Bracket hardware. Push the Bracket and Support Bracket up a little into position against the floor panel and away from the edge of the pinch weld, (Figure 8) . Level and adjust the Sidebar properly and tighten all hardware.

The instruction here is for your reference only. We strongly recommend the professional installer for best result. We are not responsible for any damage caused by the installation. Thank you for choosing our product!

Installation Instruction

Part#: IB10DAI2A

REV: 20150301

Application: For JEEP PATRIOT 07 - 14

11	Use the hole in the Support Bracket as a guide to mark the drilling location on the back of the pinch weld, (Figure 8) . Once you have marked the location, temporarily remove the Sidebar, the front Mounting Bracket and Support Bracket. Remove the plastic clips securing the plastic rocker cover to the rocker panel.
12	Use a 5/16" drill bit and carefully drill the marked location. NOTE: The plastic rocker panel cover may need to be trimmed to clear the hex bolt for the Support Bracket. IMPORTANT: Any cutting or drilling tool may break or shatter. Government regulations require safety glasses & equipment at all times when cutting or drilling.
13	Re-install the driver side front Mounting Bracket and Support Bracket. Attach the Support Bracket to the pinch weld with (1) 8mm x 35mm Hex Bolt, (1) 8mm Lock Washer, (2) 8mm Flat Washers and (1) 8mm Hex Nut, (Figure 9) . NOTE: Insert the 8mm Hex Bolt With (1) 8mm Flat Washer through the pinch weld first, then through the Bracket. Cut the rocker panel cover as required and reinstall the cover with the factory plastic clips. Reinstall the Sidebar.
14	Align and adjust the Sidebar and Brackets and tighten all hardware.
15	Repeat Steps 2- 14 for passenger Sidebar installation.
16	Do periodic inspections to the installation to make sure that all hardware is secure and tight.

TO Protect your investment, wax this product after installing. Regular waxing is recommended to add a protective layer over the finish. Do not use any type of polish or wax that may contain abrasives that could damage the finish.

For Polish Surface: Aluminum polish may be used to polish small scratches and scuffs on the finish. Mild soap may be used also to clean the Sidebar.

For black finishes: Mild soap may be used also to clean the Sidebar.

Driver Side Installation Pictured:

The instruction here is for your reference only. We strongly recommend the professional installer for best result. We are not responsible for any damage caused by the installation. Thank you for choosing our product!

Installation Instruction

Part#: IB10DAI2A

REV: 20150301

Application: For JEEP PATRIOT 07 - 14

Driver Side Installation Pictured

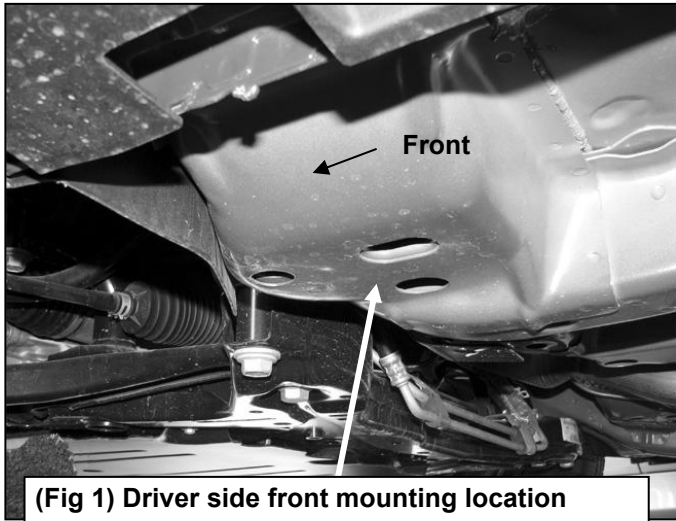

12mm Bolt Plate
12mm Flat Washer
12mm Lock Washer
12mm Hex Nut

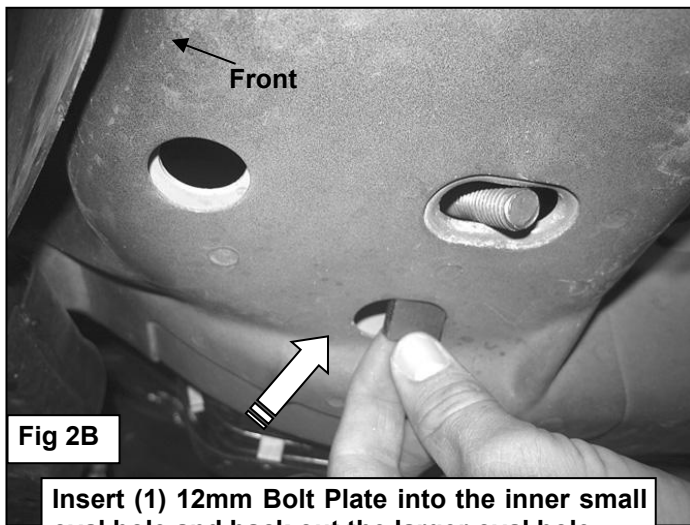

Driver side inner frame channel

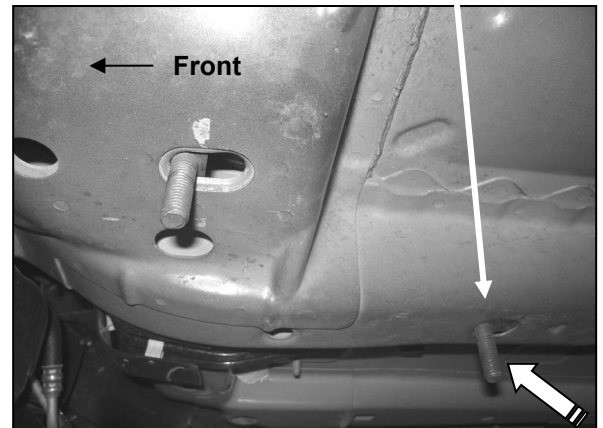

The instruction here is for your reference only. We strongly recommend the professional installer for best result. We are not responsible for any damage caused by the installation. Thank you for choosing our product!

Installation Instruction

Part#: IB10DAI2A

REV: 20150301

Application: For JEEP PATRIOT 07 - 14

Driver Side Installation Pictured

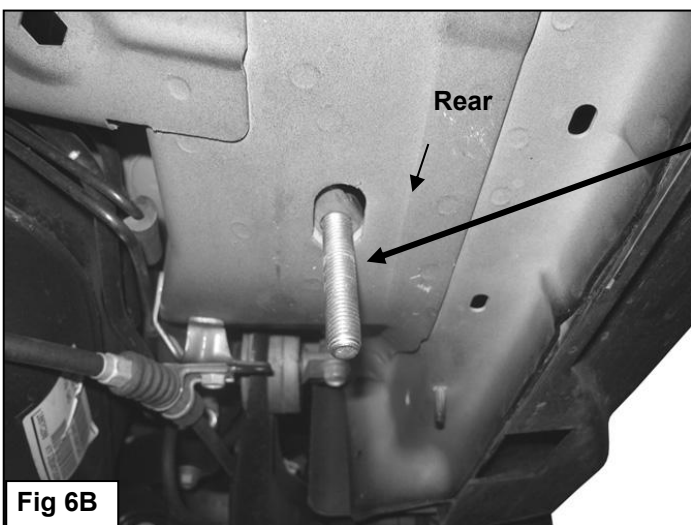
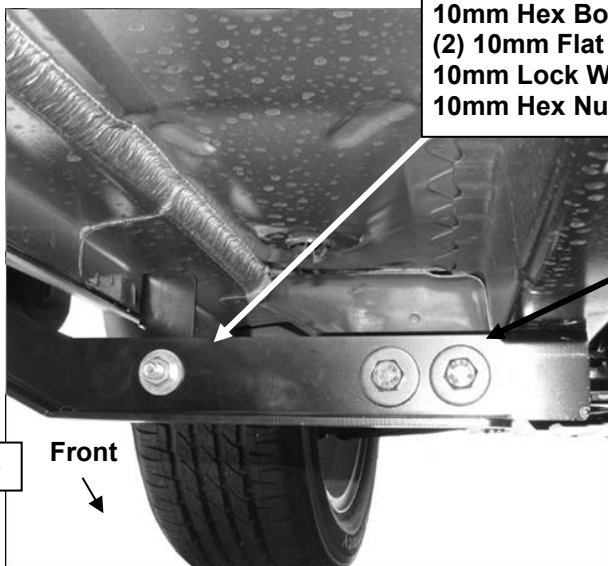
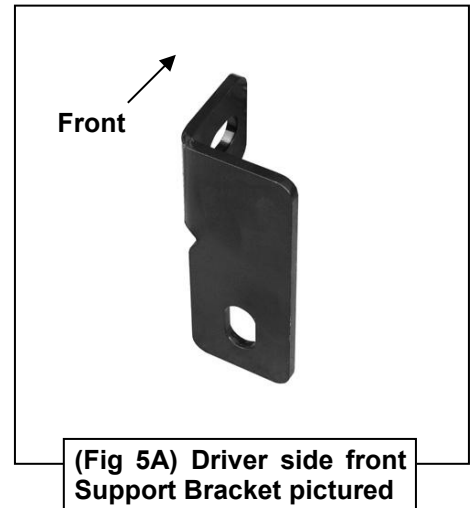
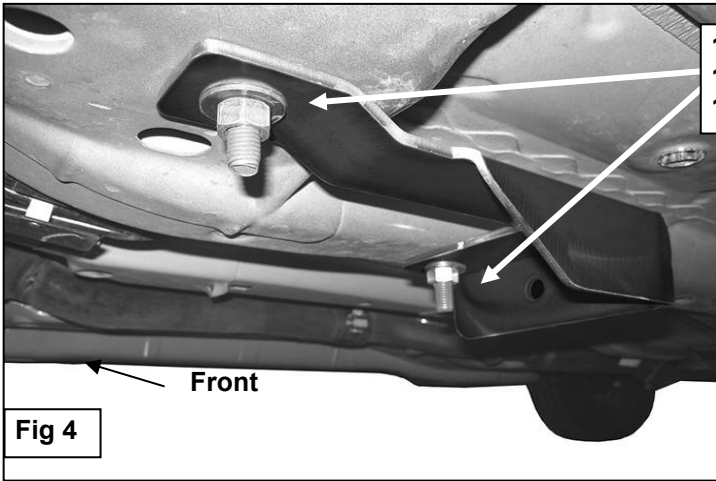

The instruction here is for your reference only. We strongly recommend the professional installer for best result. We are not responsible for any damage caused by the installation. Thank you for choosing our product!

Installation Instruction

Part#: IB10DAI2A

REV: 20150301

Application: For JEEP PATRIOT 07 - 14

Driver Side Installation Pictured

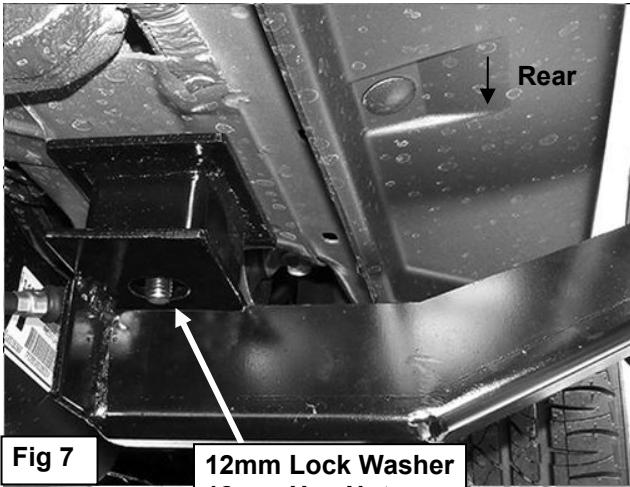

Drill 5/16" hole through marked spot on pinch weld. Do not drill close to the edge of the pinch weld

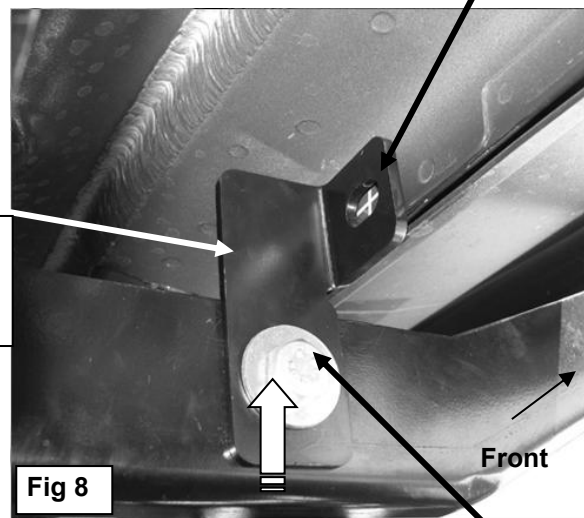

8mm x 35mm Hex Bolt
8mm Lock Washer
(2) 8mm Flat Washers
8mm Hex Nut

10mm Hex Bolt
(2) 10mm Flat Washers
10mm Lock Washer
10mm Hex Nut

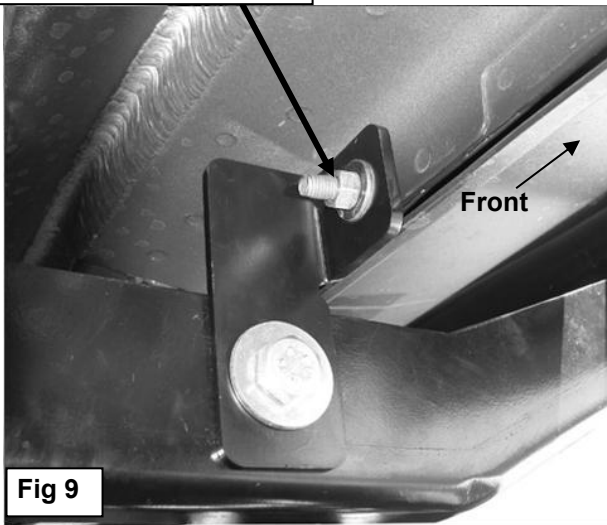

Adjust Running board. Loosen 10mm Bolt and push Support Bracket up against the floor to move slot away from edge of pinch weld

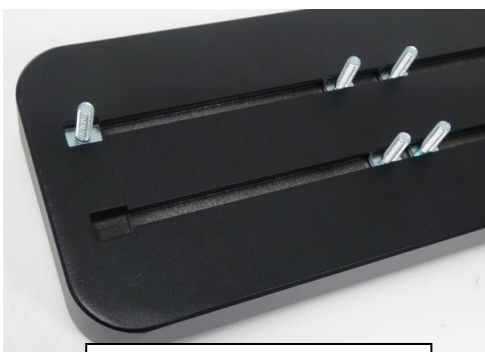

(4)M6 Square Hex Bolt
(4)M6 Flat Washers
(4)M6 Nylon Lock Nuts

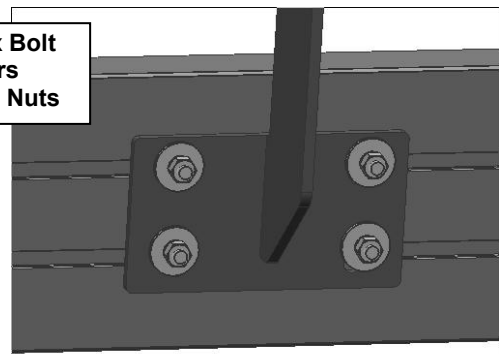

The instruction here is for your reference only. We strongly recommend the professional installer for best result. We are not responsible for any damage caused by the installation. Thank you for choosing our product!