

PARTS LIST:

Item	QTY	Description	Item	QTY	Description
#1	2	Running Board(use for left or right)	#16	4	12mm Flat Washers
#2	1	Driver/Left Front Mounting Bracket	#17	4	12mm Lock Washers
#3	1	Driver/Left Front Support Bracket	#18	4	12mm Hex Nuts
#4	1	Driver/Left Rear Mounting Bracket	#19	4	10mm x 30mm Hex Bolts
#5	1	Passenger/Right Front Mounting Bracket	#20	2	10mm x 30mm OD x 2.5mm Flat Washers
#6	1	Passenger/Right Front Support Bracket	#21	8	11mm x 20mm OD x 2mm Flat Washers
#7	1	Passenger/Right Rear Mounting Bracket	#22	6	10mm Lock Washers
#8	2	Rear Support Brackets	#23	6	10mm Hex Nuts
#9	1	8mm Threaded Insert Tool	#24	4	8mm x 25mm Hex Bolts
#10	4	8mm Threaded Inserts	#25	4	8mm x 24mm OD x 2mm Flat Washers
#11	2	12mm x 40mm Long Bolt Plates	#26	4	8mm Lock Washers
#12	2	12mm x 35mm Button Head T-Bolt Plates	#27	16	6-1.0mm x 20mm T-Bolts
#13	2	10mm x 35 Long Bolt Plates	#28	16	6mm x 22mm OD x 2mm Flat Washers
#14	4	12mm Plastic Retainers	#29	16	6mm Lock Nuts
#15	2	10mm Plastic Retainers			

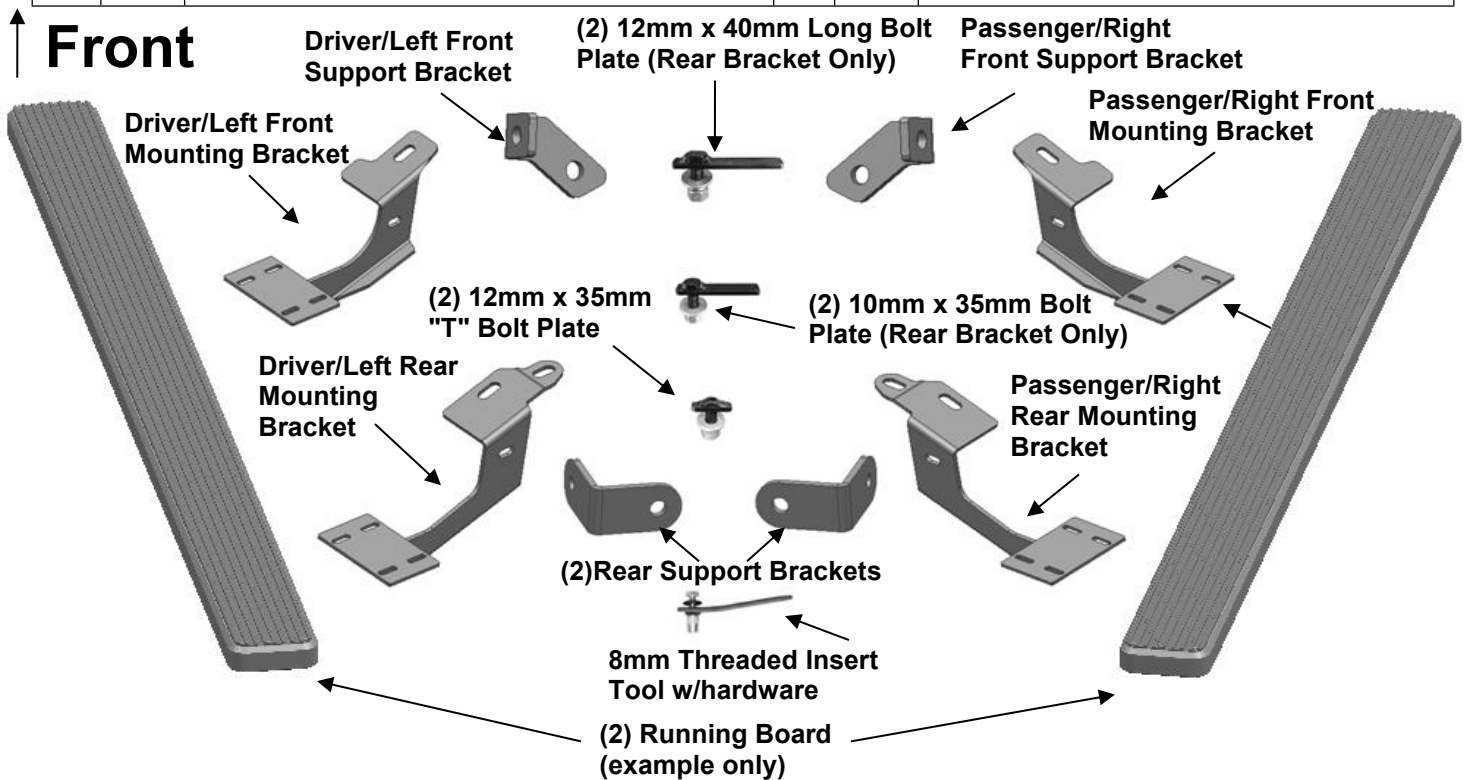

PROCEDURE:

- 1. REMOVE CONTENTS FROM BOX. VERIFY ALL PARTS ARE PRESENT. READ INSTRUCTIONS CAREFULLY BEFORE STARTING INSTALLATION. DRILLING IS REQUIRED. ASSISTANCE IS RECOMMENDED.**
- Start installation under the driver side of the vehicle. Select (1) 12mm x 35mm Small T-Bolt Plate and insert it into the factory oval hole in the floor panel, **(Figures 1A & 1B)**. Rotate the Bolt Plate 90-degrees so that the plate is across the oval hole. Select the driver side front Mounting Bracket. Hang the Bracket from the Bolt Plate with (1) 12mm Flat Washer, (1) 12mm Lock Washer and (1) 12mm Hex Nut, **(Figure 2)**. **NOTE:** Make sure that the mounting flange on the front Bracket is lined up properly with the indent in the floor panel. The front Mounting Bracket must sit flat against the floor panel. Do not tighten hardware at this time.

3. Select the driver side front Support Bracket, **(Figure 3A)**. Bolt the Support Bracket to the back of the front Bracket with (1) 10mm x 30mm Hex Bolt, (2) 10mm x 20mm Flat Washers, (1) 10mm Lock Washer and (1) 10mm Hex Nut, **(Figure 3B)**. Line up the mounting tab on the Support Bracket with the back of the pinch weld. Do not tighten hardware at this time.
4. Move toward the rear location. Locate the oval and round holes in the floor panel toward the rear of the vehicle, **(Figure 4A)**. Insert (1) 10mm x 35mm Bolt Plate into the round hole, **(Figure 4B)**. Insert (1) 12mm x 40mm Long Bolt Plate into the oval hole next to the pinch weld, **(Figure 4C)**. Rotate the 12mm Bolt Plate 90-degrees so that the plate is across the oval hole.
5. Position the Rear Mounting Bracket over the (2) Bolt Plates. Secure the Bracket to the 12mm Bolt Plate with (1) 12mm Flat Washer, (1) 12mm Lock Washer and (1) 12mm Hex Nut, **(Figure 5B)**. Bolt the Bracket to the 10mm Bolt Plate with (1) 10mm x 30mm OD Large Flat Washer, (1) 10mm Lock Washer and (1) 10mm Hex Nut. Snug hardware but do not tighten at this time.
6. Next, select (1) "L" rear Support Bracket, **(Figure 5A)**. Bolt the Support Bracket to the front facing side of the rear Mounting Bracket with (1) 10mm x 30mm Hex Bolt, (2) 10mm x 20mm Flat Washers, (1) 10 Lock Washer and (1) 10mm Hex Nut, **(Figures 5B)**. Do not tighten hardware at this time.
7. Select a Running Board. Slip(8) 6mm T-bolts into each bottom channel**(Figure 6)**. Carefully position the Running Board onto the (2) Mounting Brackets. **IMPORTANT:** Do not slide, (front to back), the Running Board on the Brackets or damage to the finish may result. Attach the Running Board to the Mounting Brackets with(4) 6mm T-bolts,(4)6mm flat washers and (4)6mm lock nuts **(Figures 7)**. Do not tighten at this time.
8. Level and adjust the Running Board and tighten the Bracket to Bolt Plate hardware only. **IMPORTANT:** Do not tighten the front and rear Support Bracket hardware at this time.
9. Return to the driver side front Bracket and Support Bracket. Hold the front Support Bracket firmly against the back of the pinch weld. Mark the mounting hole location onto the back of the pinch weld, **(Figure 8)**.
10. Check the Running Board for level before proceeding. Carefully drill this location with a **7/16"** drill bit. **CAUTION:** Do not drill the hole too close to the bottom edge of the pinch weld. Remove the driver side Front Support Bracket.

VERY IMPORTANT! Be very careful and drill slowly through the pinch weld to avoid damaging the outer rocker panel cover.

NOTE: Any cutting or drilling tool may break or shatter. Government regulations require safety glasses & equipment at all times when cutting or drilling.

11. Select (1) 8mm Insert Tool, (1) 8mm Threaded Insert, (1) 8mm x 25mm Hex Bolt and (1) 8mm Flat Washer. Assemble the Insert Tool as pictured in **Figure 9**. Hold the handle and push the Insert into the drilled hole in the pinch weld. **NOTE:** Insert must fit snug in hole. If necessary, use a small hammer to carefully tap the Insert into the hole until the rim on the insert is flush against the pinch weld. Firmly hold the tool handle and tighten the Hex Bolt in the Tool to expand the Insert in the hole. Continue until threads are pulled up close to the top of the Insert, **(Figures 10 & 13)**. Remove the Tool and hardware. Bolt the Support Bracket to the Threaded Insert with (1) 8mm x 25mm Hex Bolt, (1) 8mm Lock Washer and (1) 8mm Flat Washer, **(Figure 11)**. Tighten hardware at this time.
12. Move to the driver side rear Mounting Bracket. Hold the "L" Support Bracket firmly against the back of the pinch weld. Repeat **Steps 9—11** to mark and drill the pinch weld and install the Threaded Insert, **(Figures 12 & 13)**. Reinstall the Support Bracket. Bolt the Support Bracket to the Insert with (1) 8mm x 25mm Hex Bolt, (1) 8mm Lock Washer and (1) 8mm Flat Washer, **(Figure 14)**. Tighten the front and rear Bracket hardware only at this time.
13. Reinstall the Running Board as described in **Step 7**. Check alignment, adjust as necessary and fully tighten all hardware.
14. Repeat **Steps 2—13** for passenger/right Running Board installation.
15. Do periodic inspections to the installation to make sure that all hardware is secure and tight.

To protect your investment, wax this product after installing. Regular waxing is recommended to add a protective layer over the finish. Do not use any type of polish or wax that may contain abrasives that could damage the finish.

For Polished Finishes: Aluminum polish may be used to polish small scratches and scuffs on the finish. Mild soap may be used also to clean the Running Board.

For Black Finishes: Mild soap may be used to clean the Running Board.

Driver/Left Side Installation Pictured

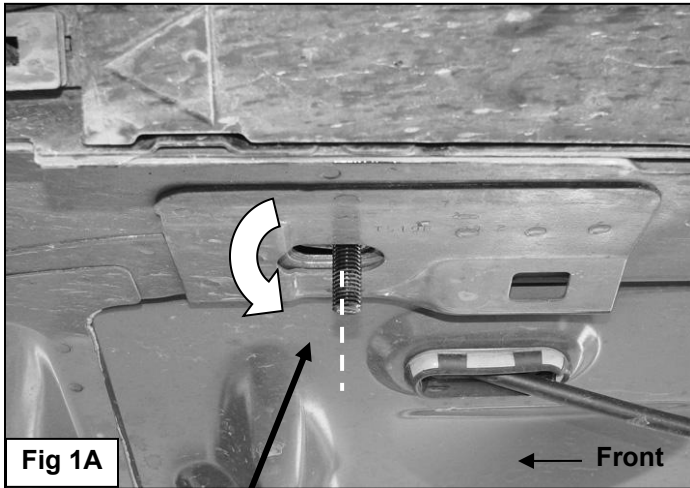

12mm Flat Washer
12mm Lock Washer
12mm Hex Nut

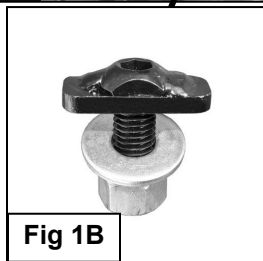
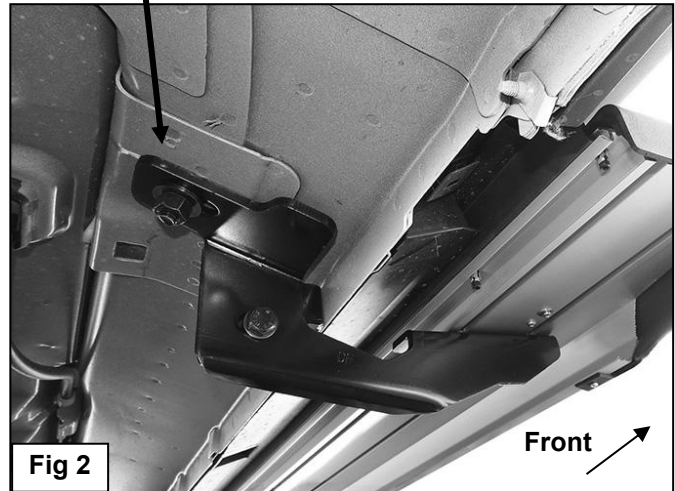

12mm x 35mm
T-Bolt Plate



10mm x 30 Hex Bolt
(2) 10mm x 20mm
Flat Washers
10mm Lock Washer
10mm Hex Nut

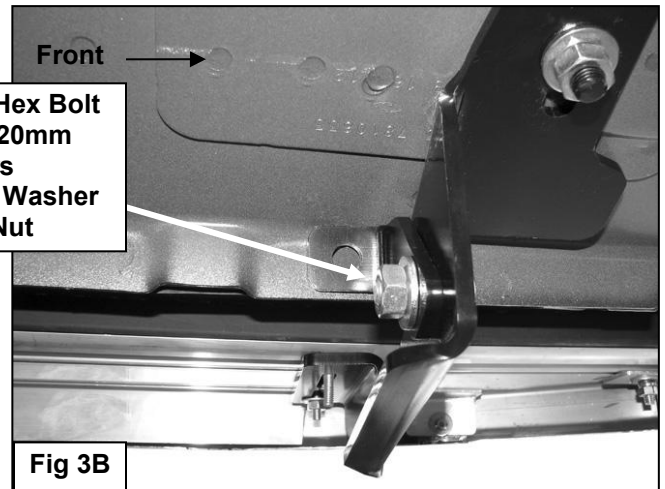

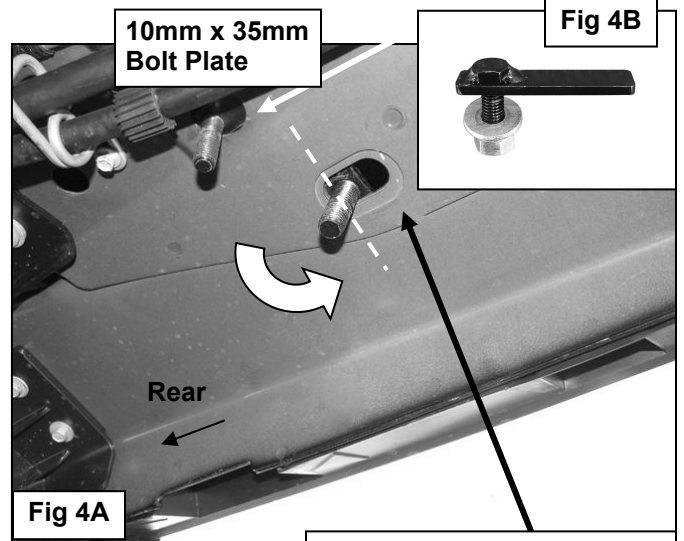
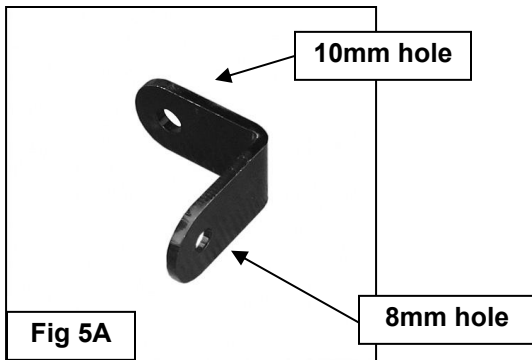

10mm Large Flat Washer
10mm Lock Washer
10mm Hex Nut

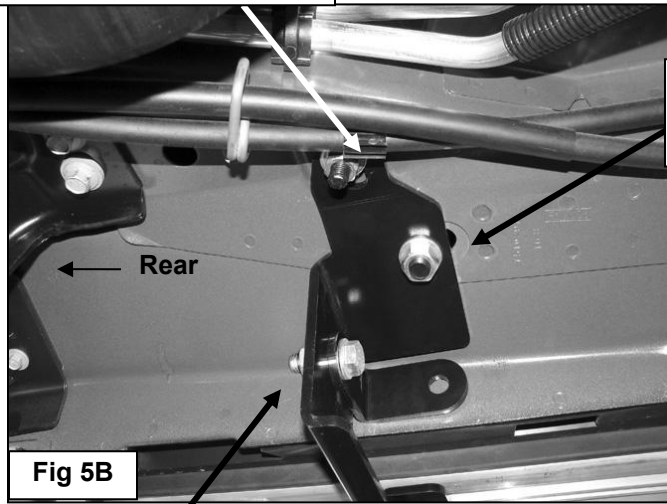

12mm Flat Washer
12mm Lock Washer
12mm Hex Nut

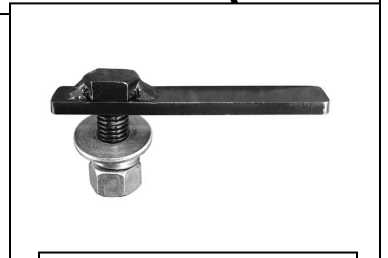

(4)6mm T-bolts
(4)6mm Flat Washers
(4)6mm Lock nuts

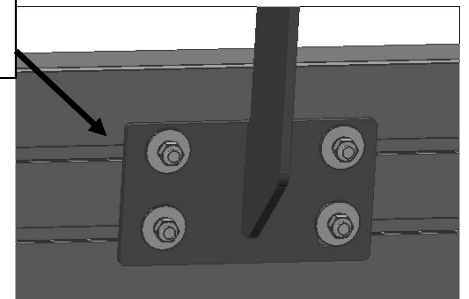

(1)10mm x 30 Hex Bolt
(2) 10mm Flat Washers
(1)10mm Lock Washer
(1)10 Hex Nut

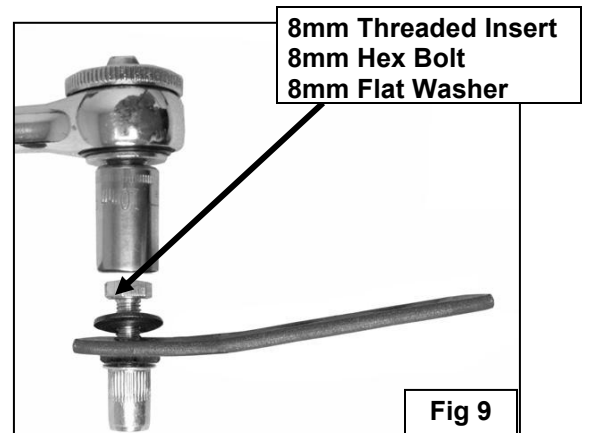
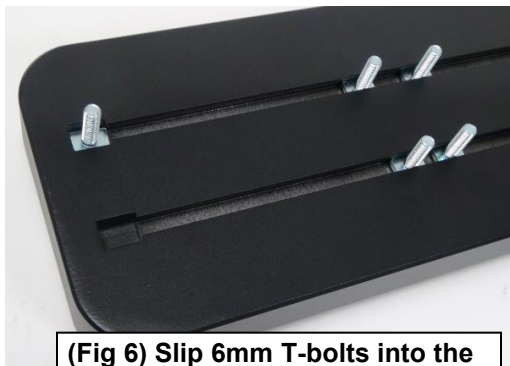

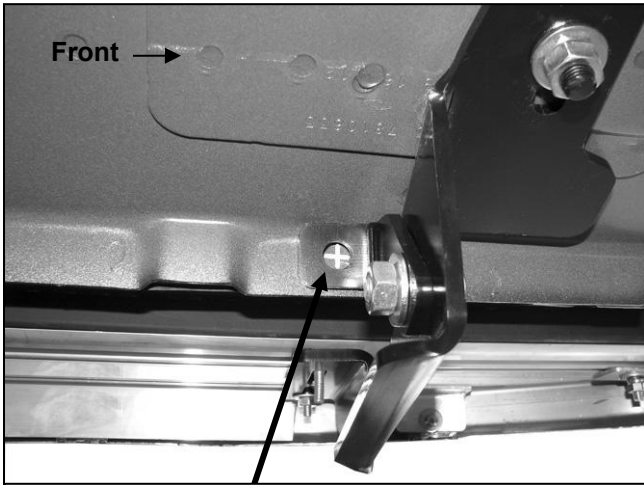

(Fig 8) Mark Support Bracket location onto pinch weld. Carefully drill the location with 7/16" drill bit. Do not drill and install the Insert until after the Sidebar has been completely installed, checked for level and aligned on the vehicle. Repeat procedure to install all Inserts.

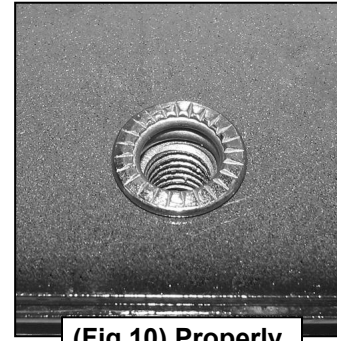

(Fig 10) Properly installed Insert

- 8mm Threaded Insert
- 8mm x 25mm Hex Bolt
- 8mm Lock Washer
- 8mm x 22mm Flat Washer

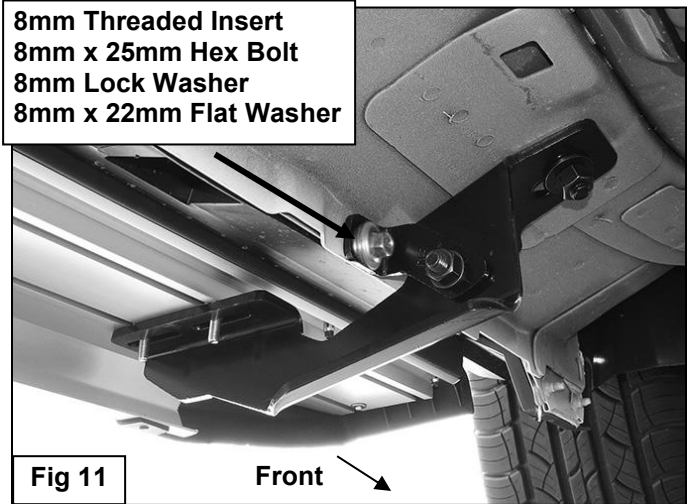
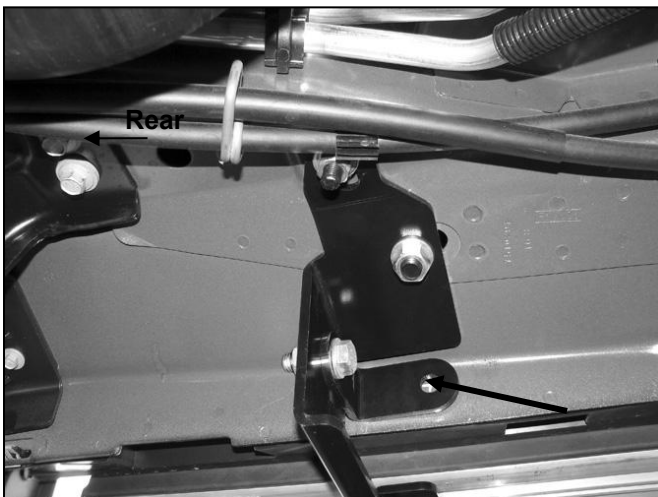

Fig 11

Front

Mark location of Support Bracket onto pinch weld. Carefully drill the location with 7/16" drill



(Fig 12) Driver side rear Bracket pictured

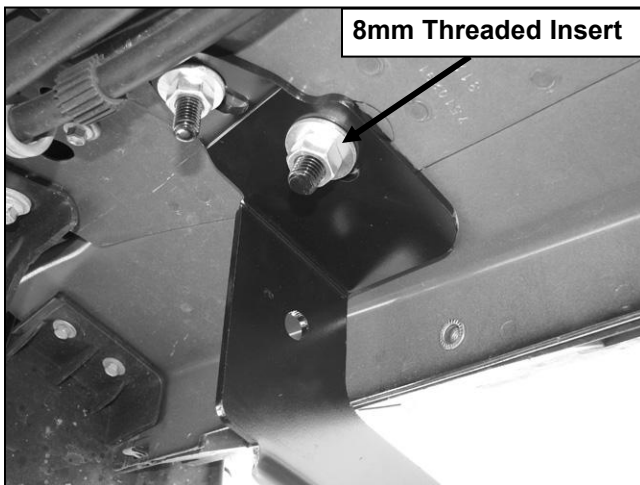

(Fig 13) Driver side rear Bracket pictured

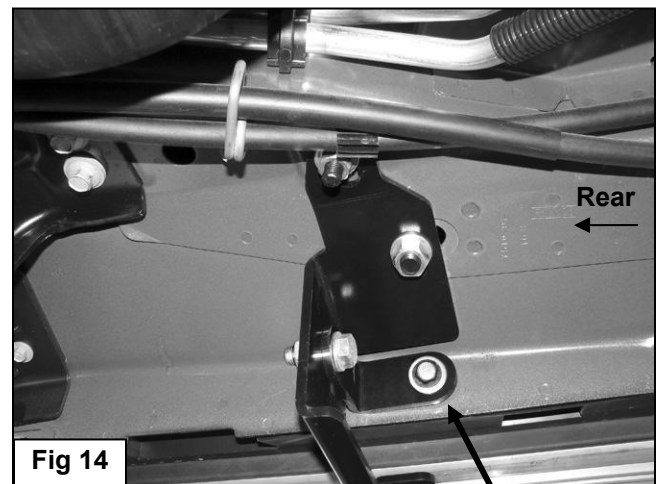

Fig 14

- 8mm x 25mm Hex Bolt
- 8mm Lock Washer
- 8mm x 22mm Flat Washer