

# Installation Instructions for IB-F008

by APS Auto Parts Specialist Inc.

Application: FOR 1999-2003 Ford F-150/F-250LD Super Cab 4Dr. (Incl. 04 Heritage Model)  
Estimated Time: 1 to 2 hours



Disclaimer: Instructions intended for persons aged 18+ please do not attempt without adult supervision. Instructions are not intended to replace professional installation. Damage from improper installation, misuse or modification to the product voids the manufacturer's warranty.

**PARTS LIST:**

Item	QTY	Description	Item	QTY	Description
#1	2	Running Board(use for left or right)	#7	8	M10 Lock Washers
#2	2	Front Mounting Bracket (angled)(DFM/PFM)	#8	8	10mm x 30mm OD x 2.5mm Flat Washers
#3	2	Rear Mounting Bracket (straight) (DRM/PRM)	#9	8	M10 Hex Nuts
#4	4	M10 x 35mm Large Double Bolt Plates	#10	8	M6-1.0mm x 20mm T-Bolts
#5	1	M10 x 35mm Small Double Bolt Plates (use for 3-door )	#11	8	6mm x 22mm OD x 2mm Flat Washers
#6	2	10mm Plastic Retainers (3-door only)	#12	8	M6 Nylon Lock Nuts



DFM/PFM

DRM/PRM

**PROCEDURE:**

1. REMOVE CONTENTS FROM BOX. VERIFY ALL PARTS ARE PRESENT. READ INSTRUCTIONS CAREFULLY BEFORE STARTING INSTALLATION.
2. Start installation from under the driver/left side of the vehicle. Remove the large oval rubber cover located on the inner side panel toward the front, **(Figure 1)**. Insert (1) Double Bolt Plate into the oval hole, **(Figure 2)**, and pull it back into position against the inner body panel, **(Figure 3)**.
3. Select a front Mounting Bracket. **NOTE:** The Front Bracket mounting plate is angled, **(Figure 5)**, the mounting plate on the Rear Bracket is straight up and down, **(Figure 6)**. Hold the Bolt Plate in place and slide the Bracket over the threaded studs, **(Figure 7)**. Secure the Bracket to the Bolt Plate with the included (2) M10 Lock Washers, (2) M10 Flat Washers and (2) M10 Hex Nuts, **(Figure 7)**. Leave hardware loose at this time.
4. Repeat **Steps 2 – 3** for driver side Rear Bracket installation. **NOTE:** A Narrow Double Bolt Plate has been included. On 3-door models, insert the Bolt Plate into the large, round hole and line up with the smaller round hole, **(Figures 4 & 7)**. Use the included 10mm Plastic Retainers to hold the Bolt Plate in position and secure the Bracket as previously described in **Step 2**.
5. Select a Running Board. Slip (4) M6 T-Bolts into each bottom channel **(Figure 8)**. Carefully position the Running Board onto the Mounting Brackets. Attach the Running Board to the Mounting Brackets with (2) M6 T-bolts, (2) M6 flat washers and (2) M6 nylon lock nuts, **(Figure 9)**. Do not tighten hardware at this time
6. Level and adjust the Running Board and tighten all hardware at this time.
7. Repeat steps 2 – 6 for passenger Running Board.

8. Do periodic inspections of the installation to make sure all hardware is secure and tight.

**To protect your investment**, wax this product after installing. Regular waxing is recommended to add a protective layer over the finish. Do not use any type of polish or wax that may contain abrasives that could damage the finish.

**For Polished Finishes:** Aluminum polish may be used to polish small scratches and scuffs on the finish. Mild soap may be used also to clean the Running Board.

**For black finishes:** Mild soap may be used to clean the Running Board.

### Front Bolt Plate Installation Example

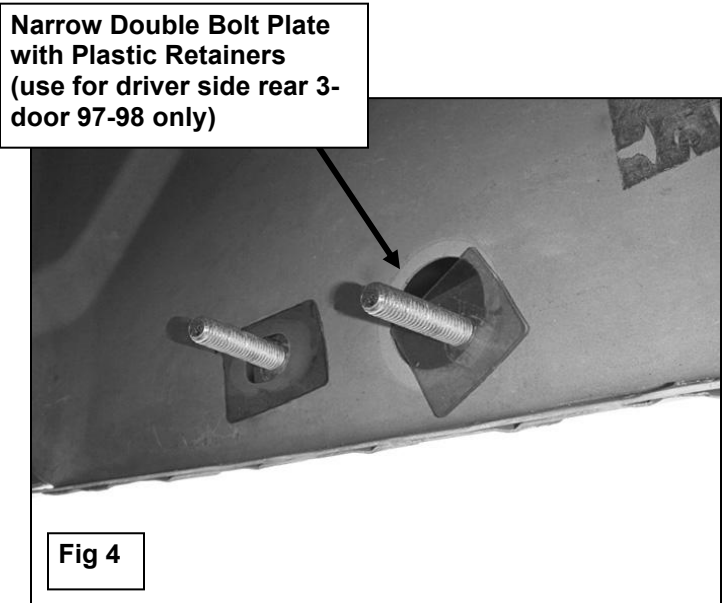
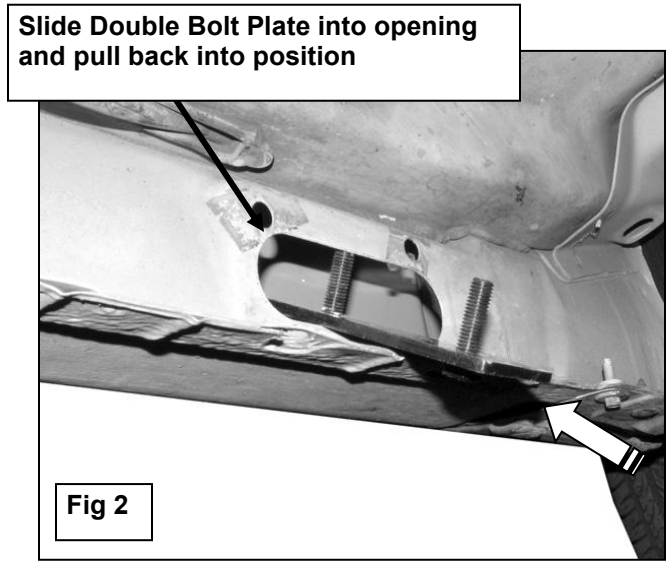
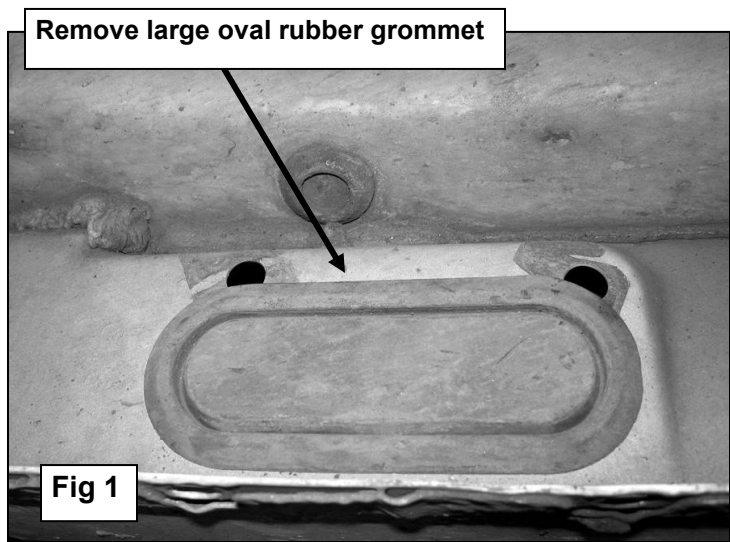



(Fig 5) front (angled) Bracket

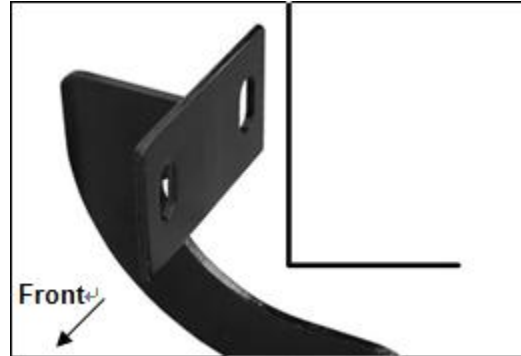

(Fig 6) rear (straight) Bracket

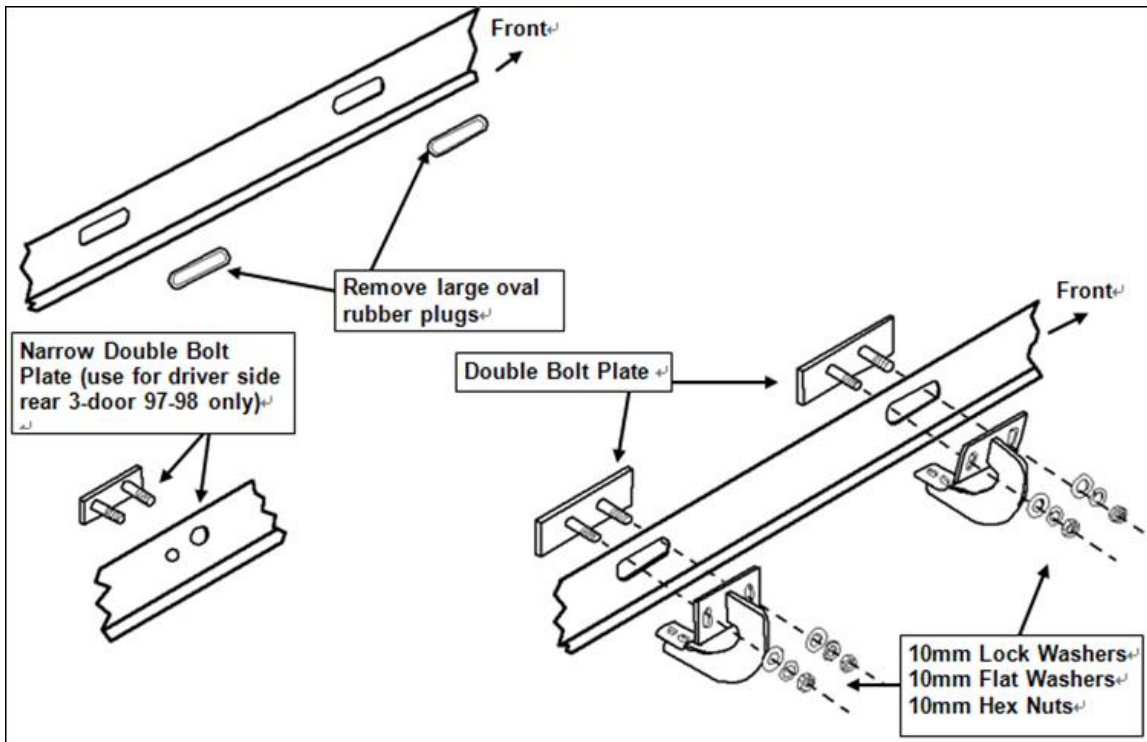

(Fig 7) Driver/Left Side Installation Illustrated



(Fig 8) Slip M6 T-bolts into the bottom channel

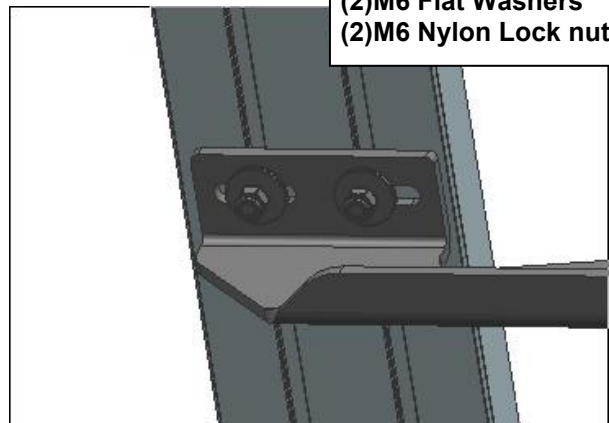

(Fig 9) Bracket Installation (example only)

- (2)M6 T-bolts
- (2)M6 Flat Washers
- (2)M6 Nylon Lock nuts