

PARTS LIST:

Item	QTY	Description	Item	QTY	Description
#1	2	Running Board(use for left or right)	#6	24	10mm Lock Washers
#2	6	Mounting Brackets(left or right) (DFM&PFM)	#7	12	10mm Hex Nuts
#3	12	10mm Clip Nuts	#8	12	6-1.0mm x 20mm T-Bolts
#4	24	10mm x 30mm Hex Bolts	#9	12	6mm x 22mm OD x 2mm Flat Washers
#5	36	10mm ID x 27mm OD x3mm Flat Washers	#10	12	6mm Lock Nuts

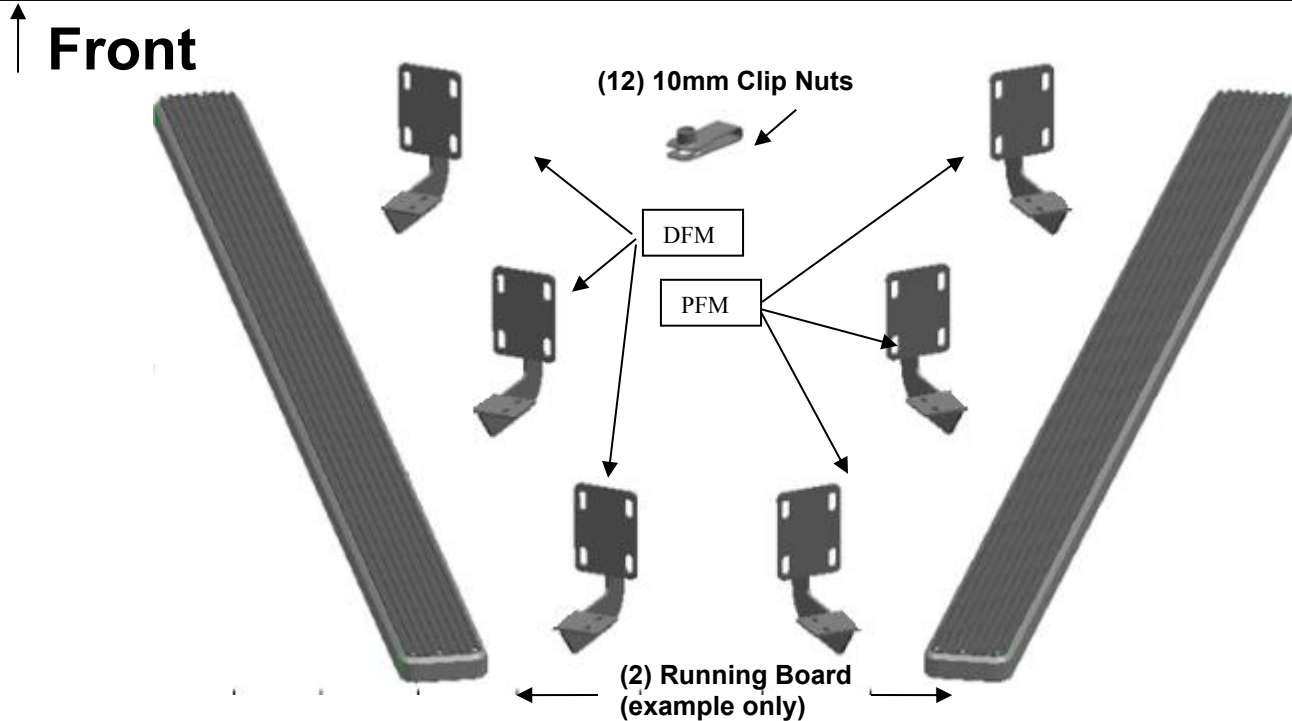

PROCEDURE:

- REMOVE CONTENTS FROM BOX. VERIFY ALL PARTS ARE PRESENT. READ INSTRUCTIONS CAREFULLY BEFORE STARTING INSTALLATION. ASSISTANCE IS RECOMMENDED.**
- Starting on the driver side-front of the vehicle, locate the (5) pairs of factory holes along the bottom of the body, (pinch weld). Move to the 2nd pair of holes directly under the center of the front door, **(Figures 1 & 2)**. Each mounting location on the inner body panel is comprised of a rectangular hole with a round hole on each side directly above each pair of holes in the pinch weld, **(Figures 1 & 3)**.
- Select (2) 10mm Clip Nuts. Insert Clip Nuts one at a time into the rectangular opening and slide the threaded hole outward towards the round hole. Line up the threaded hole in the Clip with the round hole next to the rectangular opening. **NOTE:** Threaded nut must go towards the inside of the side panel, **(Figures 3 & 4)**.
- Partially attach (1) Mounting Bracket to the Clip Nuts with the included (2) 10mm x 30mm Hex Bolts, (2) 10mm Lock Washers and (2)10mm Flat Washers, **(Figure 5)**. **NOTE:** Cradles on the Mounting Brackets should face the front of the vehicle.
- Bolt the (2) bottom holes in the Mounting Bracket to the (2) holes in the pinch weld with the included (2) 10mm x 30mm Hex Bolts, (4) 10mm Flat Washers, (2) 10mm Lock Washers and (2) 10mm Hex Nuts, **(Figure 5)**. **NOTE:** Insert the Hex Bolt with Flat Washer through the pinch weld first then through the Bracket from the outside to inside. Do not tighten hardware at this time.
- Move along the vehicle to the next(Center) mounting location, **(Figure 6)**. Repeat **Steps 2—5** to install (1) Mounting Bracket in the center location. Do not tighten hardware at this time. **NOTE:** There are (5) mounting locations along the inner body panel. Running Board installation will use the 2nd,3rd,and 5th mounting locations, **(Figure 1)**.
- Repeat **Steps 2—5** to attach (1)Mounting Bracket to the rear location**(Figure 6)**.Do not tighten hardware at this time.

8. Select a Running Board. Slip(12)6mm T-bolts into each bottom channel(**Figure 7**). Carefully position the Running Board onto the (3) Mounting Brackets. **IMPORTANT:** Do not slide, (front to back), the Running Board on the Brackets or damage to the finish may result. Attach the Running Board to each Mounting Brackets with(2) 6mm T-bolts,(2)6mm flat washers and (2)6mm lock nuts (**Figures 8**). Do not tighten at this time.
9. Level and adjust Running Board properly and tighten all hardware.
10. Repeat **Steps 2—9** for passenger/right Running Board installation.
11. Do periodic inspections to the installation to make sure that all hardware is secure and tight.

To protect your investment, wax this product after installing. Regular waxing is recommended to add a protective layer over the finish. Do not use any type of polish or wax that may contain abrasives that could damage the finish.

For Polished Finishes: Aluminum polish may be used to polish small scratches and scuffs on the finish. Mild soap may be used also to clean the Running Board.

For Black Finishes: Mild soap may be used to clean the Running Board.

Driver Side Installation Pictured

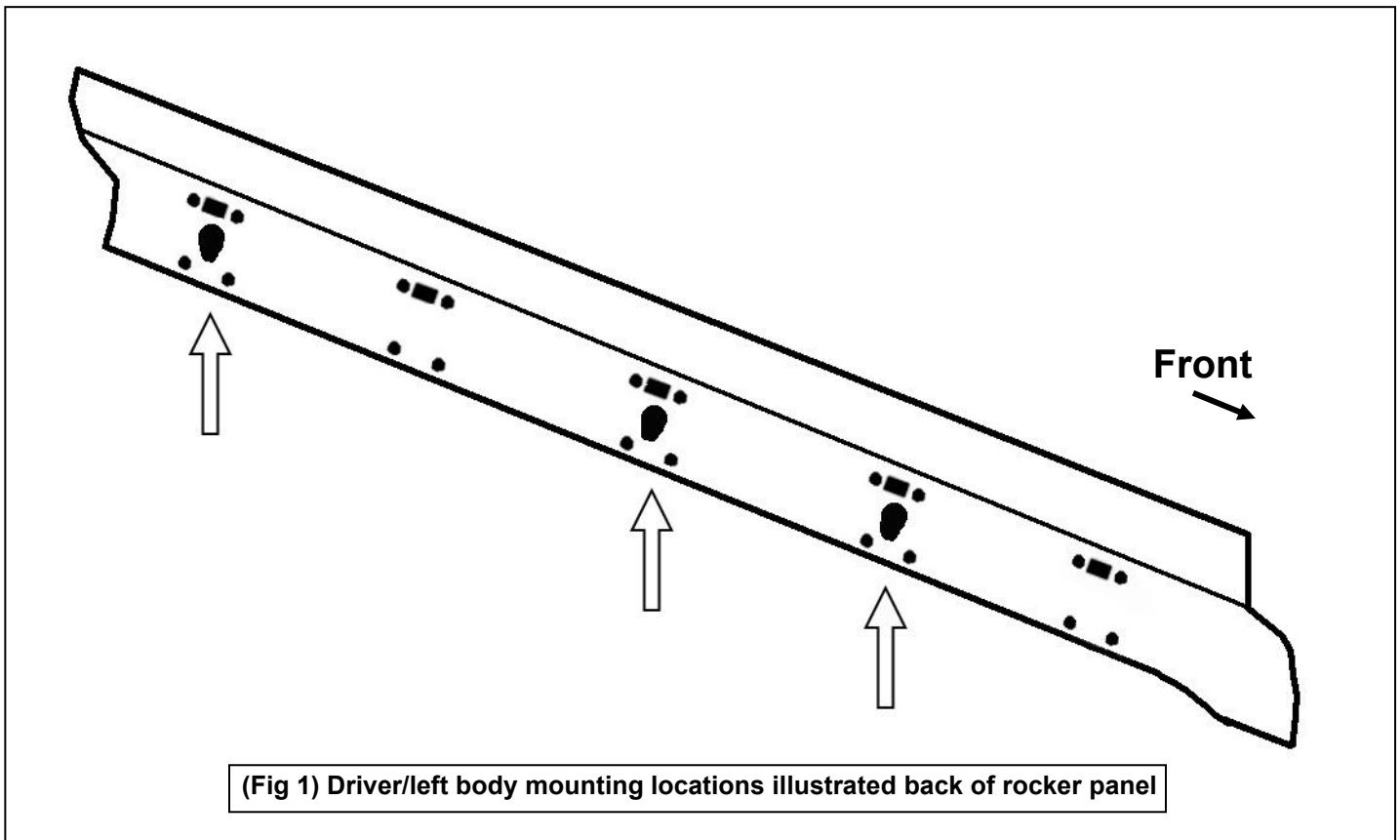

Driver Side Installation Pictured

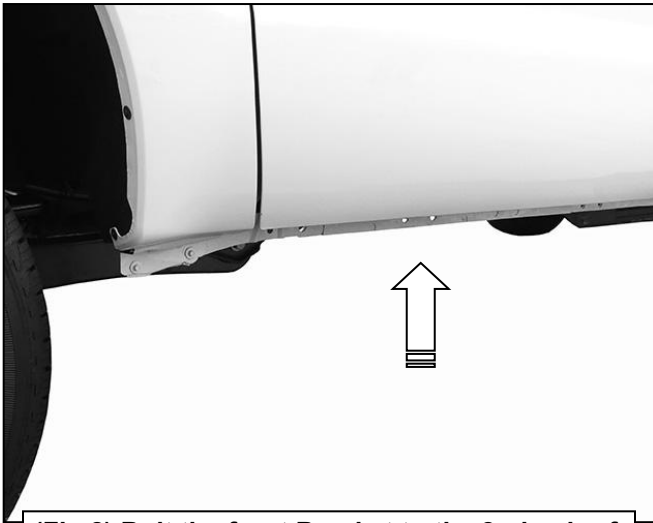

(Fig 2) Bolt the front Bracket to the 2nd pair of factory holes in the bottom of the pinch weld

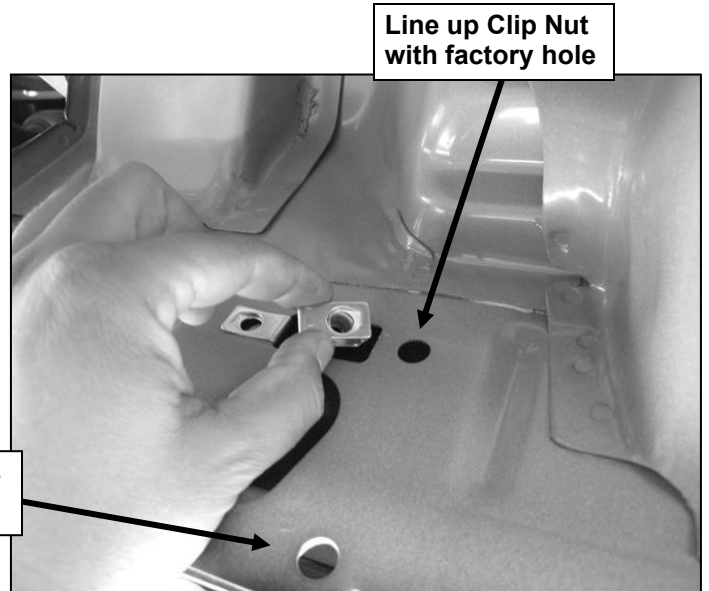

(Fig 3) Typical Mounting Location

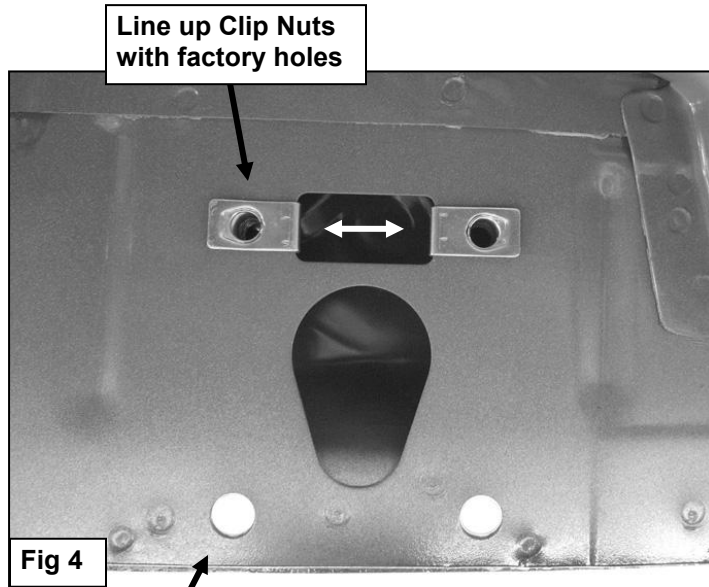

Line up Clip Nuts with factory holes

Fig 4

Factory holes in pinch weld pictured from behind body panel

- (2) 10mm x 30mm Hex Bolts
- (4) 10mm Flat Washers
- (2) 10mm Lock Washers
- (2) 10mm Hex Nuts

- (10) 10mm Clip Nuts
- (10) 10mm x 30mm Hex Bolts
- (10) 10mm Lock Washers
- (10) 10mm Flat Washers



(Fig 5) Front Bracket installation pictured

Driver Side Installation Pictured

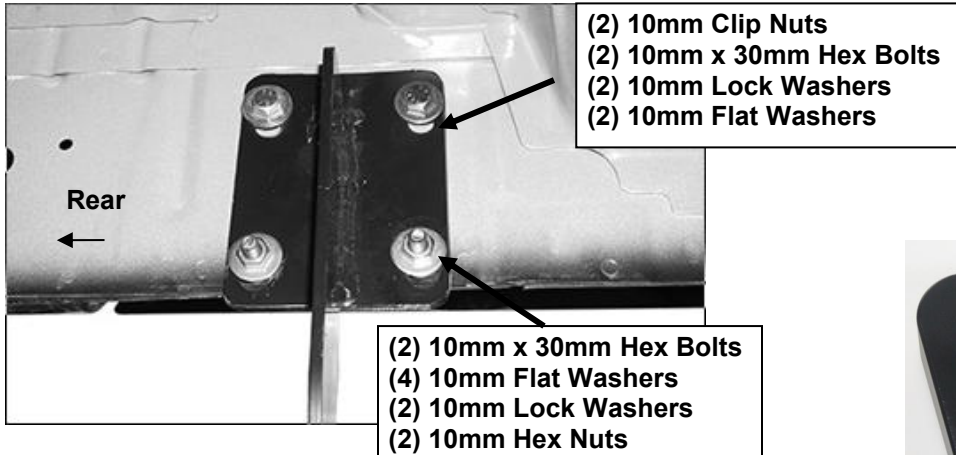

(Fig 6) Driver/left center/rear Bracket installation pictured

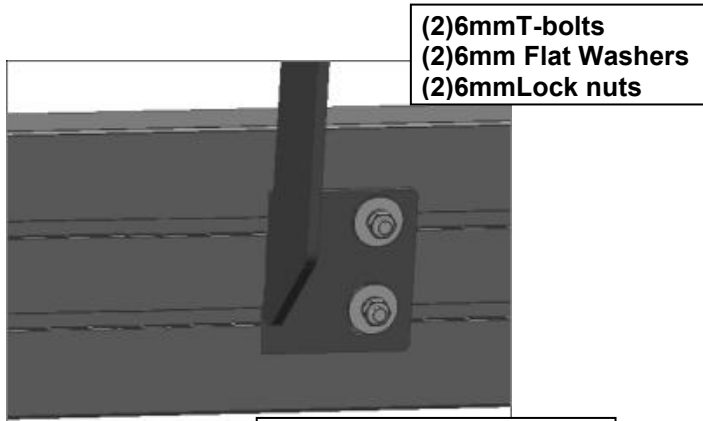

(Fig 7) Slip 6mm T-bolts into the bottom channel

(Fig 8) Bracket Installation



Complete Installation