

PARTS LIST:

Item	QTY	Description	Item	QTY	Description
#1	2	Running Board(use for left or right)	#6	16	10mm Lock Washers
#2	4	Mounting Brackets(left or right)	#7	8	10mm Hex Nuts
#3	8	10mm Clip Nuts	#8	16	6-1.0mm x 20mm T-Bolts
#4	16	10mm x 30mm Hex Bolts	#9	16	6mm x 22mm OD x 2mm Flat Washers
#5	24	10.5mm ID x 30mm OD x 2.5mm Flat Washers	#10	16	6mm Lock Nuts

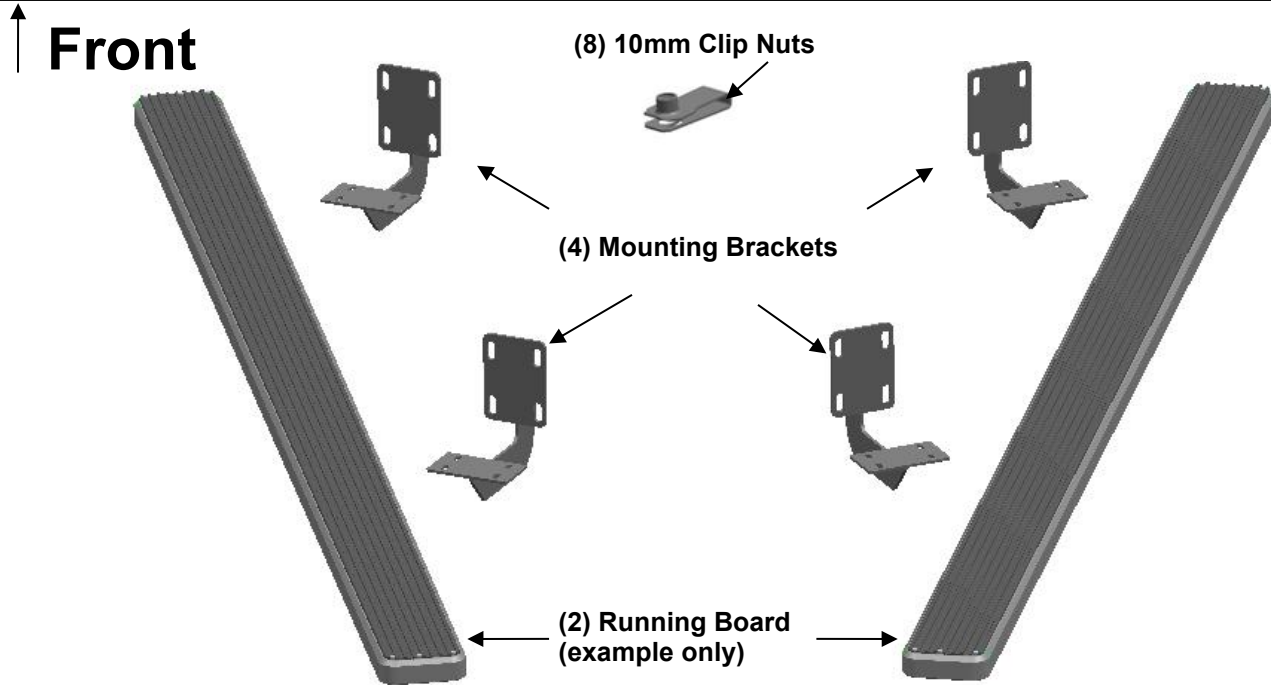

PROCEDURE:

1. REMOVE CONTENTS FROM BOX. VERIFY ALL PARTS ARE PRESENT. READ INSTRUCTIONS CAREFULLY BEFORE STARTING INSTALLATION. ASSISTANCE IS RECOMMENDED.
2. Starting on the driver side-front of the vehicle, For super cab, locate the (4) pairs of factory holes along the bottom of the body, (pinch weld). Move to the 2nd pair of holes directly under the center of the front door, **(Figures 1 & 2)**. Each mounting location on the inner body panel is comprised of a rectangular hole with a round hole on each side directly above each pair of holes in the pinch weld, **(Figures 1 & 3)**.
3. Select (2) 10mm Clip Nuts. Insert Clip Nuts one at a time into the rectangular opening and slide the threaded hole outward towards the round hole. Line up the threaded hole in the Clip with the round hole next to the rectangular opening. **NOTE:** Threaded nut must go towards the inside of the side panel, **(Figures 3 & 4)**.
4. Partially attach (1) Mounting Bracket to the Clip Nuts with the included (2) 10mm x 30mm Hex Bolts, (2) 10mm Lock Washers and (2) 10mm Flat Washers, **(Figure 5A)**. **NOTE:** Cradles on the Mounting Brackets should face the front of the vehicle.
IMPORTANT: On most model years of regular cab., the front mounting location will only use (1) Clip Nut. You can mount the running board with three bolts or once Mounting Bracket is fully installed, use it for a template to mark and drill the fourth hole in the side panel for the additional Clip Nut. Hardware has been provided **(Figure 5B)**.
5. Bolt the (2) bottom holes in the Mounting Bracket to the (2) holes in the pinch weld with the included (2) 10mm x 30mm Hex Bolts, (4) 10mm Flat Washers, (2) 10mm Lock Washers and (2) 10mm Hex Nuts, **(Figure 5)**. **NOTE:** Insert the Hex Bolt with Flat Washer through the pinch weld first then through the Bracket from the outside to inside. Do not tighten hardware at this time.

6. Move along the vehicle to the rear driver side, mounting location, (**Figure 6**). Repeat **Steps 2—5** to install a Mounting Bracket in the rear location. **NOTE:** There are (4) mounting locations along the inner body panel. Running Board installation will use the 2nd, and 4th mounting locations, (**Figure 1**).
7. Select a Running Board. Slip (8) 6mm T-bolts into each bottom channel (**Figure 7**). Carefully position the Running Board onto the (2) Mounting Brackets. **IMPORTANT:** Do not slide, (front to back), the Running Board on the Brackets or damage to the finish may result. Attach the Running Board to the Mounting Brackets with (4) 6mm T-bolts, (4) 6mm flat washers and (4) 6mm lock nuts (**Figures 8**). Do not tighten at this time.
8. Level and adjust Running Board properly and tighten all hardware.
9. Repeat **Steps 2—9** for passenger/right Running Board installation.
10. Do periodic inspections to the installation to make sure that all hardware is secure and tight.

To protect your investment, wax this product after installing. Regular waxing is recommended to add a protective layer over the finish. Do not use any type of polish or wax that may contain abrasives that could damage the finish.

For Polished Finishes: Aluminum polish may be used to polish small scratches and scuffs on the finish. Mild soap may be used also to clean the Running Board.

For Black Finishes: Mild soap may be used to clean the Running Board.

Driver Side Installation Pictured

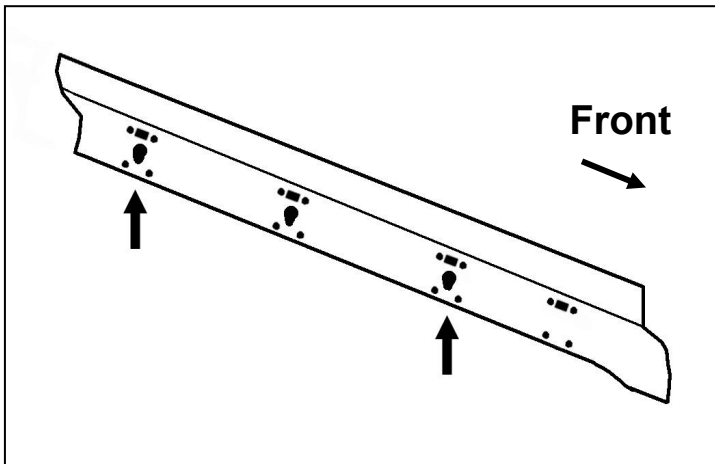

(Fig 1) Driver/left body mounting locations illustrated back of rocker panel (for super cab)

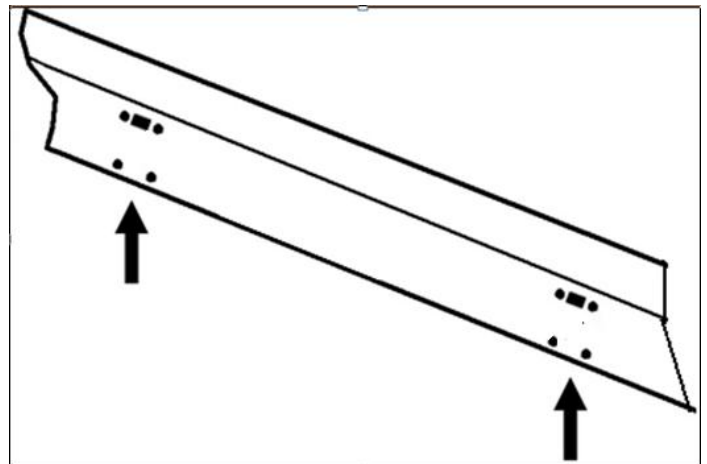

(Fig 1) Driver/left body mounting locations illustrated back of rocker panel (for regular cab)

Driver Side Installation Pictured

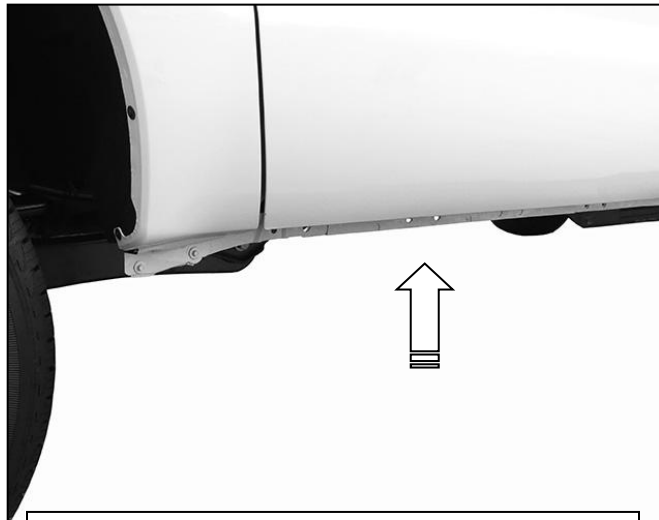

(Fig 2) Bolt the front Bracket to the 2nd pair of factory holes in the bottom of the pinch weld

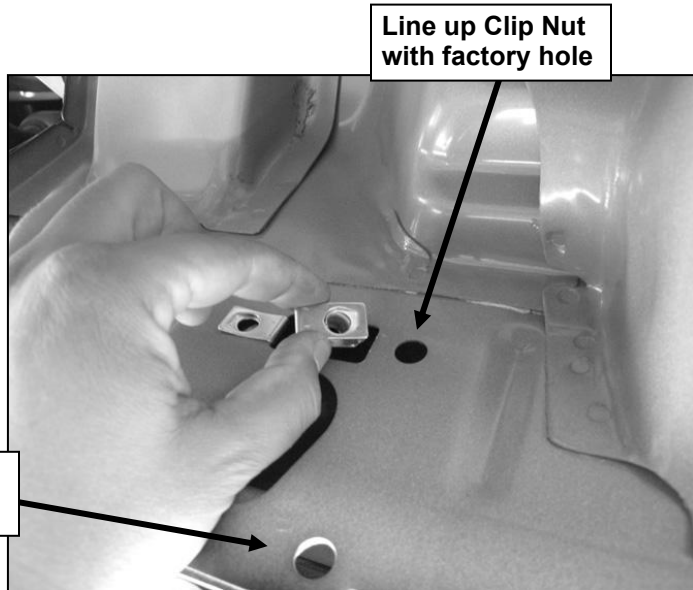

Line up Clip Nut with factory hole

Factory holes in pinch weld

(Fig 3) Typical Mounting Location

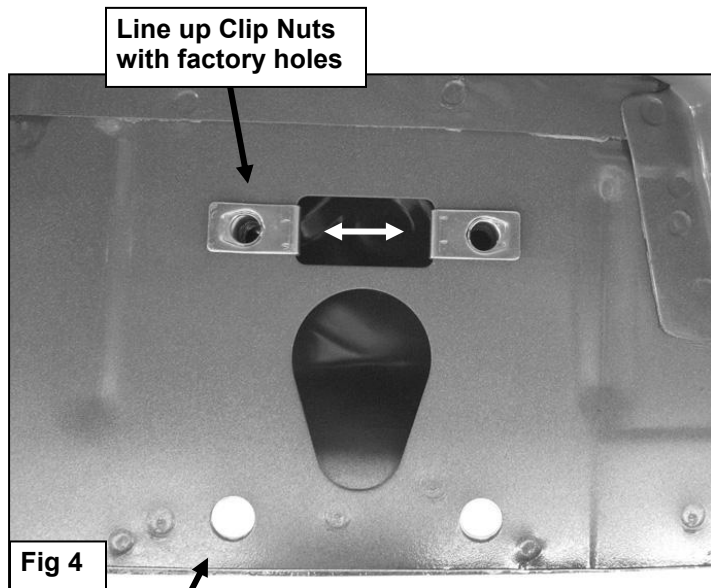

Line up Clip Nuts with factory holes

Fig 4

Factory holes in pinch weld pictured from behind body panel

- (2) 10mm x 30mm Hex Bolts
- (4) 10mm Flat Washers
- (2) 10mm Lock Washers
- (2) 10mm Hex Nuts

- (2) 10mm Clip Nuts
- (2) 10mm x 30mm Hex Bolts
- (2) 10mm Lock Washers
- (2) 10mm Flat Washers



Front
→

(Fig 5A) Front Bracket installation pictured

Driver Side Installation Pictured

Drilling required here to install optional 4th Clip Nut for mounting bolt on Front Bracket

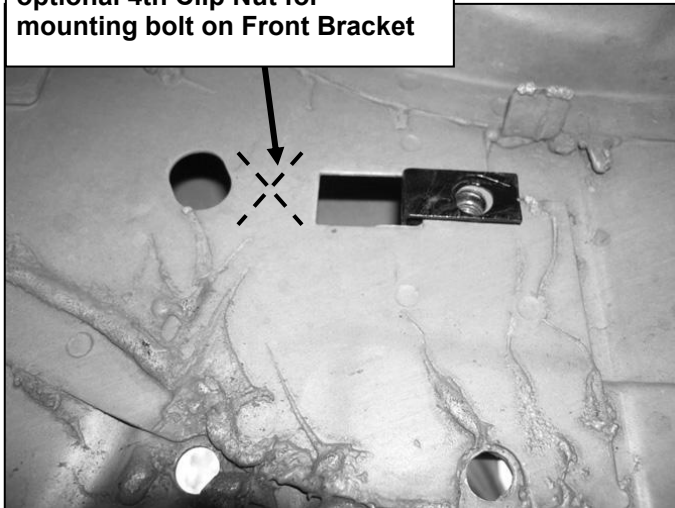

(Fig 5B) Typical Front Mounting Location for regular cab

- (2) 10mm Clip Nuts
- (2) 10mm x 30mm Hex Bolts
- (2) 10mm Lock Washers
- (2) 10mm Flat Washers

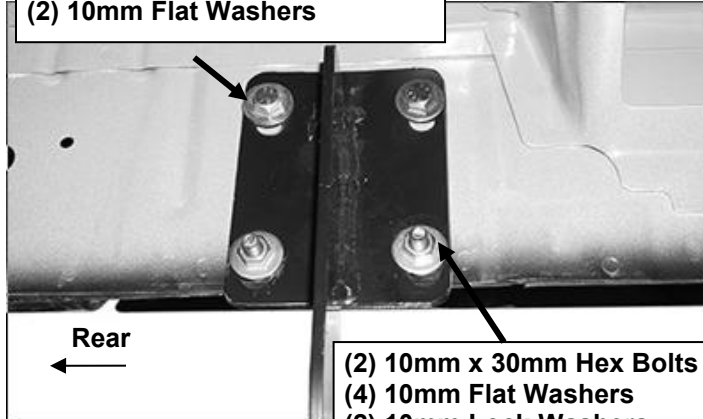

- (2) 10mm x 30mm Hex Bolts
- (4) 10mm Flat Washers
- (2) 10mm Lock Washers
- (2) 10mm Hex Nuts

(Fig 6) Driver/left rear Bracket installation pictured



(Fig 7) Slip 6mm T-bolts into the bottom channel

- (4) 6mm T-bolts
- (4) 6mm Flat Washers
- (4) 6mm Lock nuts

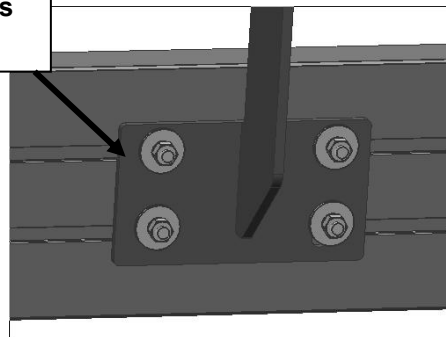

(Fig 8) Drive side Front/Rear Bracket Installation

