

## Installation Instructions for **IB04EAG9/IB04EBJ8/IB04EBJ9** by APS Auto Parts Specialist Inc.

Application: For 2009-2018 Dodge Ram 1500 Quad Cab/Crew Cab/  
2010-2018 Dodge Ram 2500/3500/4500/5500 Crew Cab/  
2010-2018 Dodge Ram 2500/3500 Mega Cab

Estimated Time: 1 to 2 hours



Disclaimer: Instructions intended for persons aged 18+ please do not attempt without adult supervision. Instructions are not intended to replace professional installation. Damage from improper installation, misuse or modification to the product voids the manufacturer's warranty.

**PARTS LIST:**

Item	QTY	Description	Item	QTY	Description
#01	2	Running Board(use for left or right)	#09	24	M8 Flat Washers
#02	3	Driver Mounting Brackets (DFM/DCM/DRM)	#10	12	M8 Lock Washers
#03	3	Passenger Mounting Brackets(PFM/PCM/PRM)	#11	6	M8 Hex Nuts
#04	3	Driver Support Brackets(DFS/DCS/DRS)	#12	6	M8 Nylon Lock Nuts
#05	3	Passenger Support Brackets (PFS/PCS/PRS)	#13	12	M6 Hex Bolts
#06	6	M8 Nut/Bolt Plates	#14	36	M6 Flat Washers
#07	6	M8 Plastic Retainers	#15	24	M6 Nylon Lock Nuts
#08	18	M8 Hex Bolts	#16	12	M6 T- Bolts

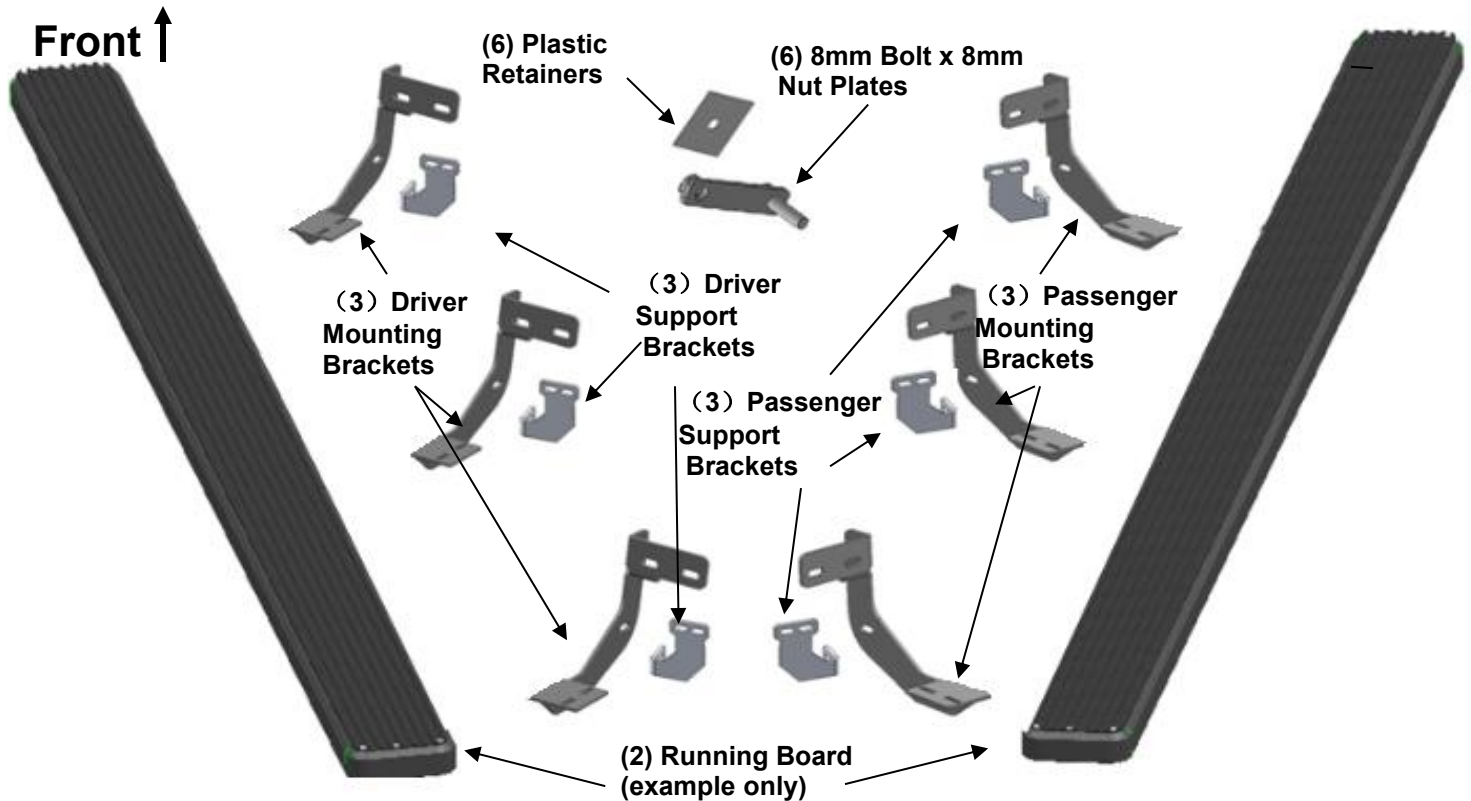

**PROCEDURE:**

1. REMOVE CONTENTS FROM BOX. VERIFY ALL PARTS ARE PRESENT. READ INSTRUCTIONS CAREFULLY BEFORE STARTING INSTALLATION. DRILLING MAY BE REQUIRED.
2. Starting at the driver side-front of the vehicle, remove the sealing tape covering the factory holes in the side of the inner panel, (Figure 1).
3. Determine the correct procedure to attach one driver side Bracket for your model/year:
 

**Models without factory threaded inserts in body panel:**

  - a. Partially thread an 8mm Hex Bolt onto the threaded end of a 8mm Bolt and Nut Plate, (Figure 2). Thread the Hex Bolt in until it is flush with the welded nut, (Figure 3). Use the Hex Bolt as a handle and insert the Bolt and Nut Plate into the oval hole, (Figure 4). Feed the threaded bolt on the Bolt Plate through one of the hex shaped factory holes. Thread (1) M8 Plastic Retainer onto the threaded end and down tight against the body panel, (Figure 5). **NOTE:** The Plastic Retainer is designed to keep the Bolt/Nut Plate from falling into the body panel and to aid in Bracket installation.
  - b. Select a driver side Mounting Bracket, (Figure 6). Attach the Bracket to the threaded end of the Bolt Plate with (1) M8 Flat Washer, (1) M8 Lock washer and (1) M8Hex Nut, (Figure 7). Do not tighten at this time.

- c. Remove the M8 Hex Bolt from the nut on the Bolt Plate from **Step 3a**. Rotate the Bolt on the Bolt Plate until the threaded nut lines up with the remaining hole in the Mounting Bracket and body panel, (**Figures 7 & 8**). Attach the Bracket to the threaded Nut Plate with (1) M8 Hex Bolt, (1) M8 Lock Washer and (1) M8 Flat Washer, (**Figure 8**). Do not fully tighten hardware at this time.

**Models with factory threaded inserts:**

- a. Attach the driver side Bracket to the threaded inserts with (2) M8 Hex Bolts, (2) M8 Lock Washers and (2) M8 Flat Washer, (**Figures 9 & 10**). Leave hardware loose.
4. Next, select a driver side Support Bracket. Attach the Bracket to the front facing side of the front Bracket with (1) M8 Hex Bolt, (2) M8 Flat Washers and (1) M8 Nylon Lock Nut, (**Figure 11**). Rotate the Support Bracket to the back of the pinch weld. Line up the slots in the top of the Support Bracket with the (2) factory holes in the pinch weld. Attach the Bracket to the back of the pinch weld with (2) M6 Hex Bolts, (4) M6 Flat Washers and (2) M6 Nylon Lock Nuts, (**Figures 12 & 13**). Do not fully tighten hardware at this time. **IMPORTANT:** 2009-10 models are not equipped with factory holes and will require drilling through the pinch weld to attach the Support Bracket. Do not drill through pinch weld at this time, (**see Step 8**).
5. Move along the side of the body panel to the center mounting location, (**Figure 14**). Repeat the appropriate **Step 3** to install the driver side center Bracket, (**Figure 1**). **IMPORTANT:** The front , center and rear driver Mounting Brackets are universal. Select (1) driver side Support Bracket. Repeat **Step 4** to attach the Support Bracket to the back of the center bracket and factory holes (if equipped) in the pinch weld, (**Figure 14**).
6. Move to the rear location, (**Figure 15**). Repeat **Step 5** to install the rear Mounting Bracket, (**Figure 16**).
7. Once all (3) Brackets have been installed, Select a Running Board. Slip (12) M6 T- Bolts into each bottom channel (**Figure 17**). Carefully position the Running Board onto the Mounting Brackets. Attach the Running Board to the Mounting Brackets with (2) M6 T- Bolts, (2) M6 flat washers and (2) M6 nylon lock nuts, (**Figure 18**). Do not tighten hardware at this time
8. Properly level and adjust the Running Board and fully tighten all hardware. **NOTE: Torque all M6 nylon lock nuts to 7 lb-ft.**

**2009-10 models requiring drilling for driver side Support Brackets:**

- a. Make sure the Running Board is level to the vehicle. Adjust and tighten all mounting hardware.
- b. Line up the slots on the Support Brackets with the back of the pinch weld. Mark the location of the slots onto the pinch weld.
- c. Drill (2) 1/4" holes through the pinch weld for each Support Bracket. **IMPORTANT:** Do not drill too close to the bottom edge of the pinch weld. Adjust the Brackets as necessary to move the slots up the body panel away from the edge. Drill the holes toward the outside of the marked slots.
- d. Attach each Support Bracket to the pinch weld with (2) M6 Hex Bolts, (4) M6 Flat Washers and (2) M6 Nylon Lock Nuts, (**Figures 12, 13, 16,**). Check for level then fully tighten all hardware.
9. Move to the passenger side of the vehicle. Remove tape covering front, center and rear locations. Repeat **Steps 2—8** for passenger side Mounting Bracket installation. **NOTE:** Refer to the illustration on **Page 1** to identify the correct Mounting Bracket for each of the remaining locations.
10. Do periodic inspections to the installation to make sure that all hardware is secure and tight.

**To protect your investment**, wax this product after installing. Regular waxing is recommended to add a protective layer over the finish. Do not use any type of polish or wax that may contain abrasives that could damage the finish.

**For Polished Finishes:** Aluminum polish may be used to polish small scratches and scuffs on the finish. Mild soap may be used also to clean the Running Board.

**For black finishes:** Mild soap may be used to clean the Running Board.

**Driver Side Installation Pictured**

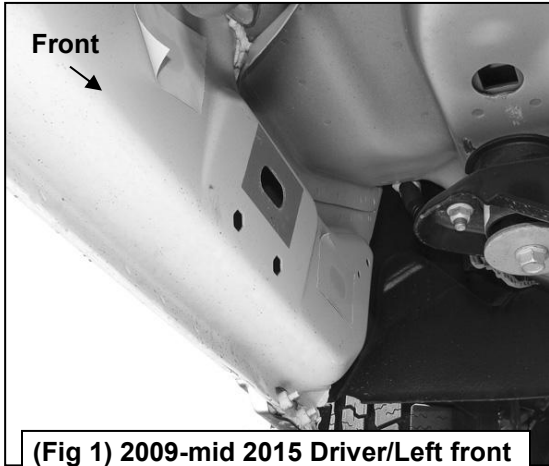

**(Fig 1) 2009-mid 2015 Driver/Left front mounting location (No factory holes in pinch weld 2009-2011 models)**

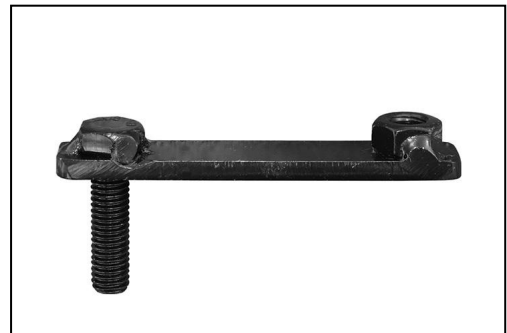

**(Fig 2) 8mm Bolt-8mm Nut Plate, NOTE: 8mm Bolt-Nut Plate is not required on models with threaded inserts**

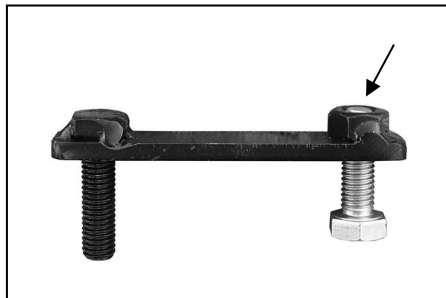

**(Fig 3) Thread (1) 8mm Hex Bolt into the nut on the plate. Stop when bolt reaches end of nut as pictured**

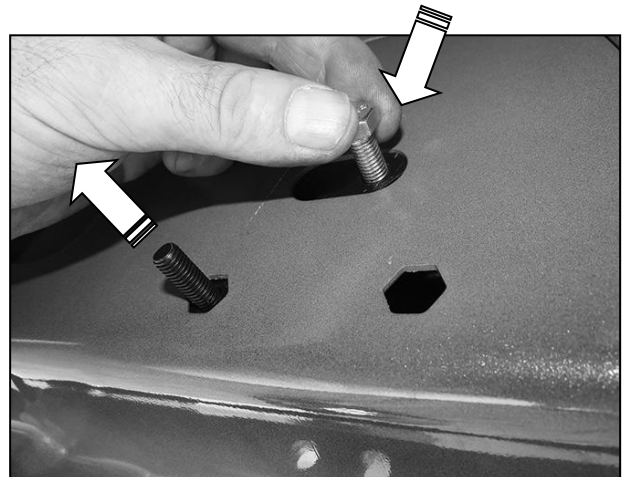

**(Fig 4) Use the loose Hex Bolt as a handle. Insert the Bolt Plate into the oval hole and feed the threaded end out either factory hex shaped hole. IMPORTANT: Do not let go of the hex bolt until after Plastic Retainer has been threaded onto bolt (Fig 5)**

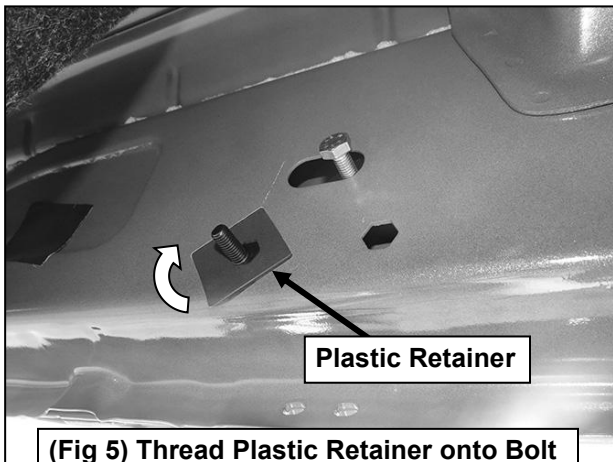

**Plastic Retainer**

**(Fig 5) Thread Plastic Retainer onto Bolt Plate to hold Bole Plate in position.**

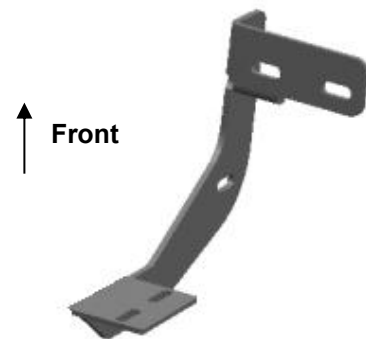

**(Fig 6) Driver side Bracket**

### Driver Side Installation Pictured

Remove Hex Bolt, rotate Bolt/Nut Plate to line up threaded nut with body panel and Mounting Bracket (see arrow)

8mm Flat Washer  
 8mm Lock Washer  
 8mm Hex Nut

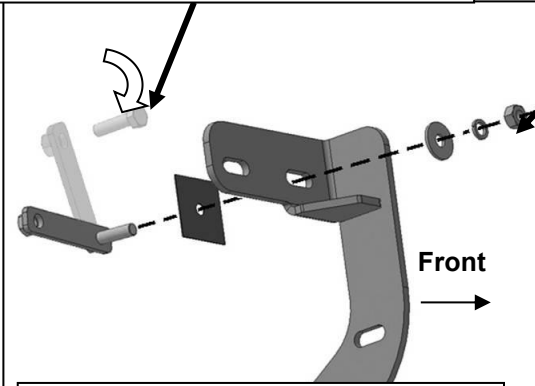

(Fig 6A) Attach Bracket to Bolt Plate

Plastic Retainer

8mm Hex Bolt  
 8mm Lock Washer  
 8mm Flat Washer

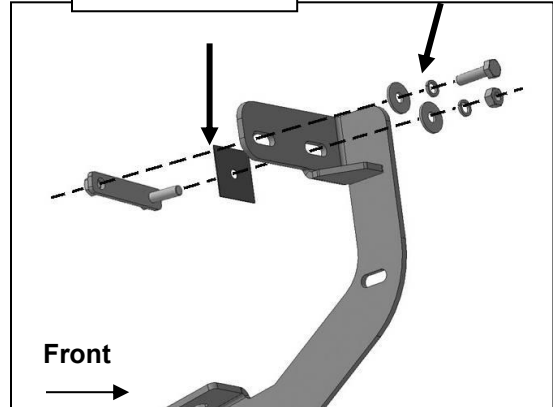

(Fig 6B) Attach Bracket to threaded end of Bolt Plate first. Remove 8mm Hex Bolt (see Fig 3). Rotate Bolt Plate to line up with remaining factory hex shaped hole.

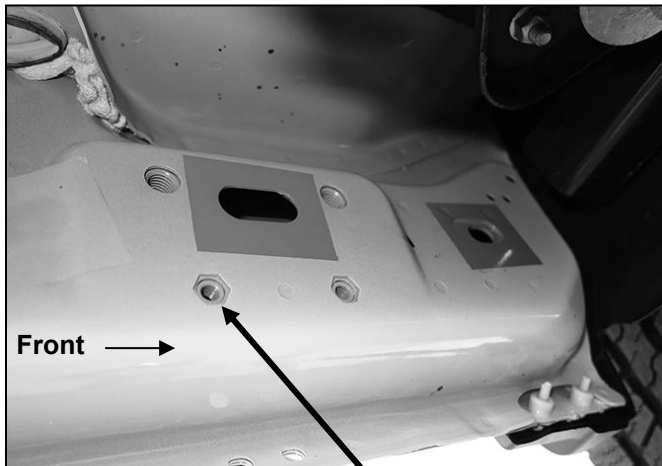

(Fig 7) Driver side front mid 2015-on, an example of models with factory installed threaded inserts

(2) 8mm Hex Bolts  
 (2) 8mm Lock Washers  
 (2) 8mm Flat Washers

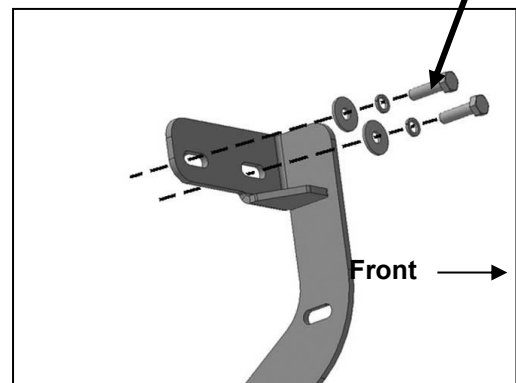

(Fig 8) Driver side front models with factory installed threaded inserts. Bolt Plate not required

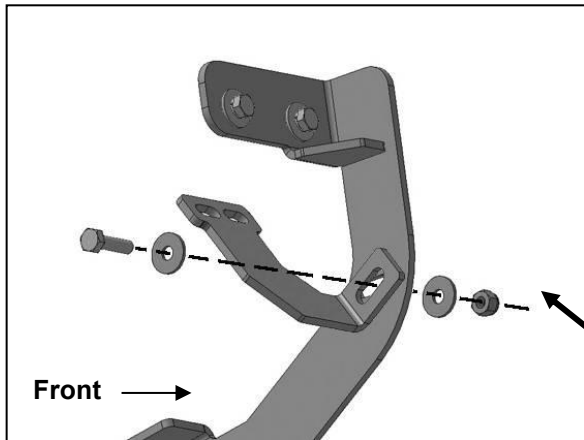

(Fig 9) Attach Driver/Left front Support Bracket to front facing side of Mounting Bracket

8mm Hex Bolt  
 (2) 8mm Flat Washers  
 8mm Nylon Lock Nut

### Driver Side Installation Pictured

- (2) M6 Hex Bolts
- (4) M6 Flat Washers
- (2) M6 Nylon Lock Nuts

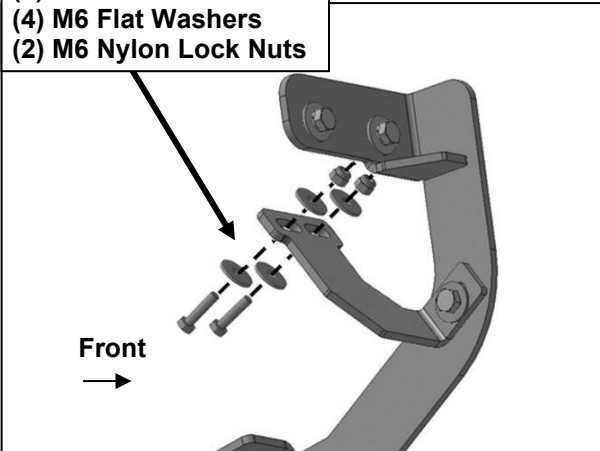

**(Fig 10) Attach Support Bracket to back of pinch weld (models with factory holes in pinch weld only)**

- (2) M6 Hex Bolts
- (4) M6 Flat Washers
- (2) M6 Nylon Lock Nuts

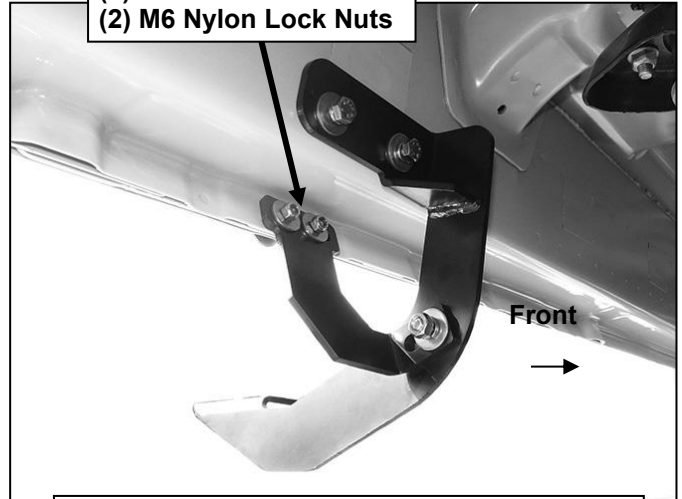

**(Fig 11) Driver side front Bracket assembly**

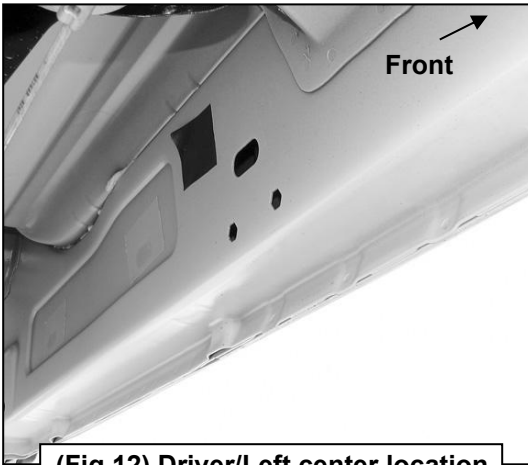

**(Fig 12) Driver/Left center location**

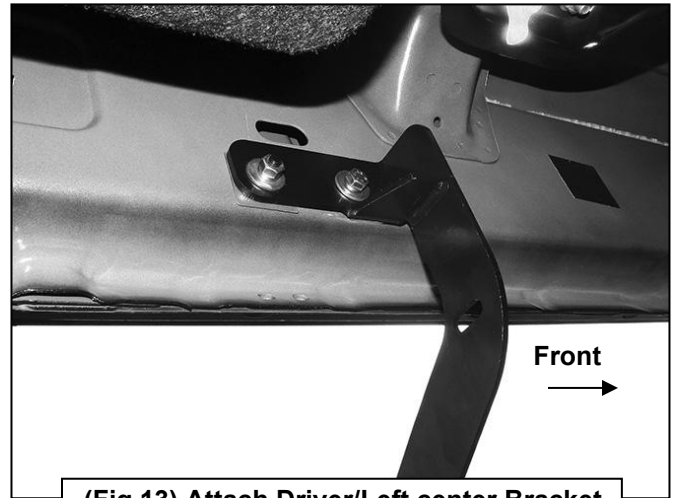

**(Fig 13) Attach Driver/Left center Bracket**

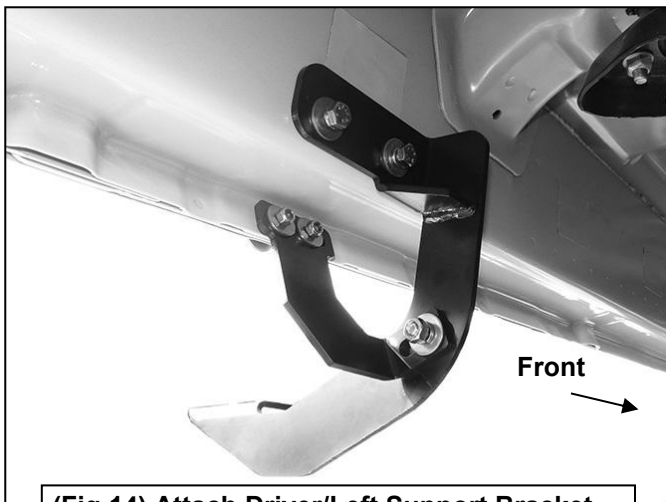

**(Fig 14) Attach Driver/Left Support Bracket to back of Center Mounting Bracket**

**IMPORTANT: 2009-2010 models without holes in pinch weld will require drilling 1/4" holes through pinch weld to attach driver side front support bracket. Do complete installation of running board first, level board before drilling holes for support bracket.**



### Driver Side Installation Pictured



(Fig 15) Driver/Left rear mounting location



(Fig 16) Driver/Left rear Mounting Bracket assembly



(Fig 17) Slip 6mm T-bolts into the bottom channel

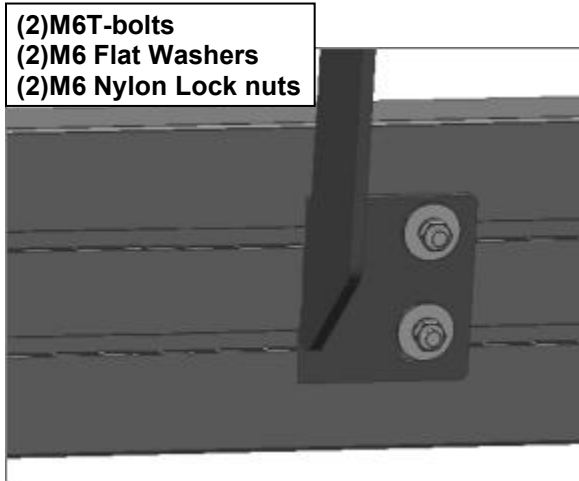

Fig 18 Bracket Installation