

iRunning Board Installation Instruction

Rev. 20170601

Application: For 07-17 Chevy/GMC Silverado/Sierra Regular Cab

PARTS LIST:

Item	QTY	Description	Item	QTY	Description
#1	2	Running Board(Driver side & Passenger Side)	#8	9	8-1.25mm x 25mm Hex Bolt
#2	1	Passenger/right Front Upper Bracket	#9	9	8mm x 24mm x 2mm Flat Washer
#3	1	Passenger/right Front Lower Bracket	#10	9	8mm Lock Washer
#4	1	Passenger /Right Rear Mounting Brackets	#11	7	8-1.25mm Clip-On Nuts
#5	2	Driver/Left Mounting Brackets	#12	8	6-1.0mm x 20mm T-Bolts
#6	1	8mm Bolt Plate	#13	8	6mm x 22mm OD x 2mm Flat Washers
#7	1	8mm Nylon Lock Nut (use w-bolt plate)	#14	8	6mm Lock Nuts



PROCEDURE:

REMOVE CONTENTS FROM BOX. VERIFY ALL PARTS ARE PRESENT. READ INSTRUCTIONS CAREFULLY BEFORE STARTING INSTALLATION. ASSISTANCE IS RECOMMENDED. ON MODELS WITH DEF TANK, SELECT A FLAT, LEVEL AREA FOR INSTALLATION.

1. Start the installation under the driver side of the vehicle. Locate the tabs along the bottom edge of the body, (pinch weld). Mounting Brackets will bolt to 2 mounting tabs, **(Figure 1)**. Directly above each tab is a top mounting location on the side of the body panel. Hold a Bracket up in place to help determine the mounting holes to use along the body.
2. Determine the correct procedure for your model year and each Bracket location.

Bottom mounting location on the edge of the pinch weld.

Flat tab on pinch weld with factory installed weld nut:

Thread hex bolt into weld nut from the backside-down to clear paint from threads, **(Figure 2)**.

Flat tab on pinch weld with hole:

Select (1) 8mm Clip Nut. Slide the Clip Nut over the tab with the nut facing up behind the tab, **(Figures 3—5)**. Line up threaded nut with hole in tab. Repeat for each mounting location.

Top mounting location on the side of the body panel.

Models with factory installed threaded insert in body panel:

Thread 8mm Hex Bolt into threaded insert to clear paint as required, **(Figures 2 & 3)**.

Large and small hole in side of body panel:

Remove the rubber plug from the larger hole, **(Figure 4)**. Select (1) 8mm Clip Nut. Slide the Clip Nut into the larger hole. Line up the threaded nut with the smaller hole, **(Figure 5)**.

3. Select (1) Mounting Bracket. **NOTE:** Bolt the Mounting Bracket to the Clip Nuts and/or the factory threaded holes with (2) 8mm Hex Bolts, (2) 8mm Lock Washers and (2) 8mm Flat Washers, **(Figures 6 & 7)**. Snug but do not fully tighten the hardware.
4. Repeat **Steps 1—3** to install the (2) remaining driver side Brackets, **(Figure 7)**.
5. Select the Running Board. Slip (2) 6mm T-Bolts into each bottom channel **(Figure 20)**. Carefully position the Running Board onto the (2) Mounting Brackets. **IMPORTANT:** Do not slide the Running Board on the Brackets or damage to the finish may result. Attach the Running Board to the Mounting Brackets with (4) 6mm T-bolts, (4) 6mm flat washers and (4) 6mm lock nuts, **(Figure 21)**. Do not tighten hardware.
6. Level and adjust the Running Board and tighten all hardware.

Application: For 07-17 Chevy/GMC Silverado/Sierra Regular Cab

7. Move to the passenger side of the vehicle. On the passenger side, determine if the vehicle is equipped with a plastic diesel exhaust fluid (DEF) tank, **(Figures 8 & 9)**.
Models without DEF tank, skip to Step 8.
Models with DEF tank: The tank sits close to the side of the body. With specialized tools, the passenger front upper and lower Bracket can be installed but room is limited. It may be easier to drop the tank down to access the inner side of the body panel for upper bracket installation. Tank will not need to be removed, only dropped down for access to mounting location. **IMPORTANT:** If tank is full, it will be very heavy and assistance is highly recommended to avoid injury or damage to the vehicle or the tank. It is recommended that installation is performed when the DEF tank is low on fluid before dropping the tank.
 - a. On models with plastic lower tray under the tank, remove the (3) hex bolts attaching the tray to the frame, **(Figure 8)**, and remove the tray. and remove tray. **2017 2500/3500 models:** Remove the (4) hex bolts attaching the plastic cover to DEF tank, **(Figure 9A)** and remove the plastic cover, **(Figure 9B)**.
 - b. Release the tank filler hose. Release the plug for the sending unit on the top of the tank.
 - c. Support the tank with a floor jack. Place a smooth flat surface, (wooden block for example), between the floor jack and the tank to avoid damaging the plastic tank. Do not push up on the tank; only support the weight of the tank with the jack.
 - d. Remove the (2) bolts securing the tank straps to the vehicle, **(Figure 10)**. Tilt the straps to release from the brackets. Slowly lower the tank until the top of the tank is almost visible. Use blocks or stands to support the tank while installing the front Upper and Lower Brackets.
 - e. Proceed to **Step 8**.
8. Locate the first tab on the edge of the pinch weld on the passenger side, **(Figures 2—4, 12 & 14)**. Select the Upper Bracket, **(Figure 11)**. Repeat **Steps 2 & 3** to attach the passenger front Upper Bracket to the side of the body panel, **(Figure 12)**. Do not tighten hardware at this time.
9. Line up the hole in the bottom of the Upper Bracket with the hole in the tab on the pinch weld.
 - a. **Models with a weld-nut:** Slide the Bracket over the weld-nut, **(Figure 12)**. Attach the Lower Bracket to the bottom of the body and weld-nut with (1) 8mm x 25mm Hex Bolt, (1) 8mm Lock Washer and (1) 8mm Flat Washer, **(Figures 15 & 16)**. Leave loose at this time.
 - b. **Models with flat tab and hole:** Insert the 8mm Bolt Plate down through the hole in the Upper Bracket and mounting tab, **(Figures 13 & 14)**. Attach the Lower Bracket to the bottom of the body and Bolt Plate with (1) 8mm Flat Washer and (1) 8mm Nylon Lock Nut, **(Figures 15 & 16)**. Leave loose at this time.
10. Line up the side tab on the Lower Bracket with the threaded hole in the side of the Upper Bracket. Attach the Lower Bracket to the Upper Bracket with (1) 8mm x 25mm Hex Bolt, (1) 8mm Lock Washer and (1) 8mm Flat Washer, **(Figure 16)**. Leave loose at this time.
11. Repeat **Steps 1—3** for the (2) remaining passenger side Bracket installations.
 - a. **2017 2500/3500 DEF tank models:** Locate the 2nd tab bracket location along the bottom edge of the body, (pinch weld), **(Figure 17)**. Hold the DEF cover in place and mark the 2nd Bracket location onto the cover, **(Figure 18)**. Use a sharp knife or hacksaw blade to carefully cut a slot in the plastic cover to clear the rear Bracket, **(Figure 19)**. Remove as little plastic as possible.
12. Repeat **Steps 5 & 6** to install the passenger Side Step, **(Figure 20)**.
13. Once the Side Steps are installed and all hardware fully tightened, reinstall the DEF tank and cover, if equipped, as described in **Step 7 & 11**.
14. Do periodic inspections to the installation to make sure that all hardware is secure and tight.

To protect your investment, wax this product after installing. Regular waxing is recommended to add a protective layer over the finish. Do not use any type of polish or wax that may contain abrasives that could damage the finish.

For Polished Finishes: Aluminum polish may be used to polish small scratches and scuffs on the finish. Mild soap may be used also to clean the Running Board.

For Black Finishes: Mild soap may be used to clean the Running Board.

iRunning Board Installation Instruction

Rev. 20170601

Application: For 07-17 Chevy/GMC Silverado/Sierra Regular Cab

Driver/Left Side Installation Pictured

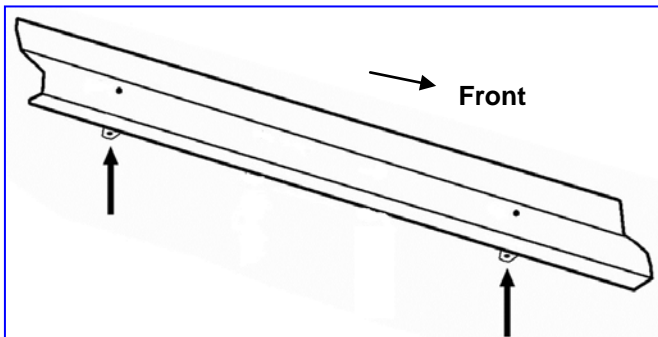

(Fig 1) Back of driver side (3) mounting locations

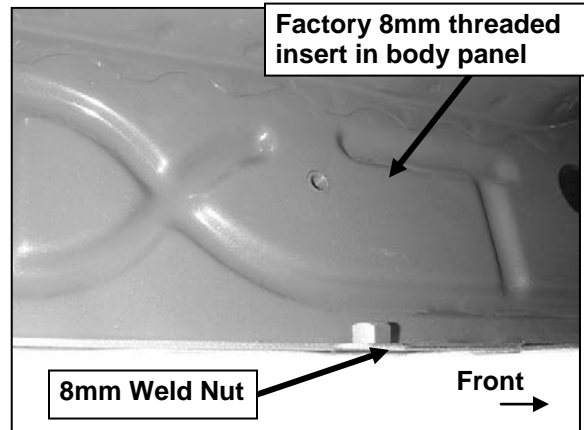

(Fig 2) Passenger side front mounting location

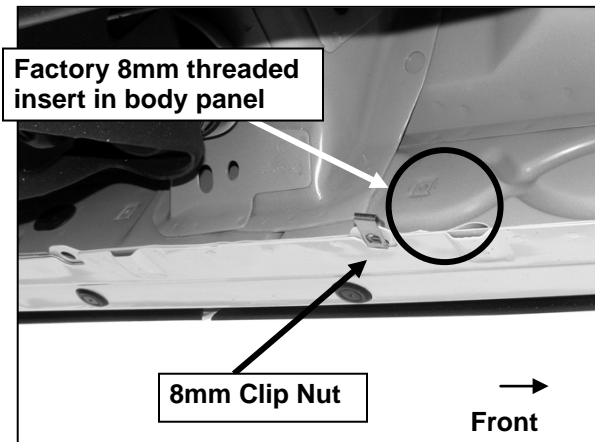

(Fig 3) Driver side rear mounting location

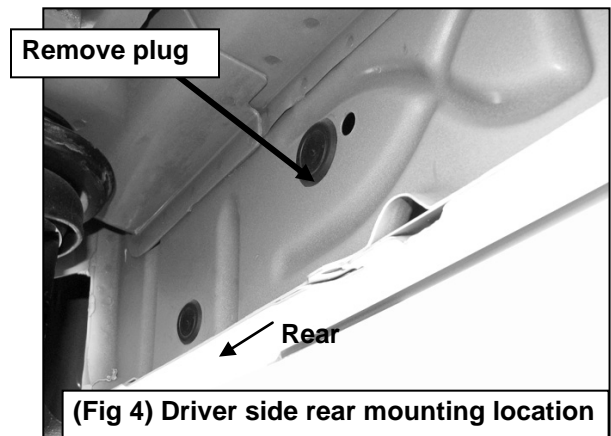

(Fig 4) Driver side rear mounting location

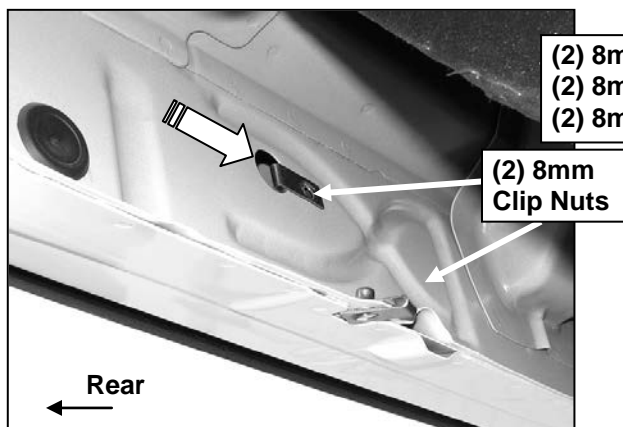

(Fig 5) Driver side rear mounting location

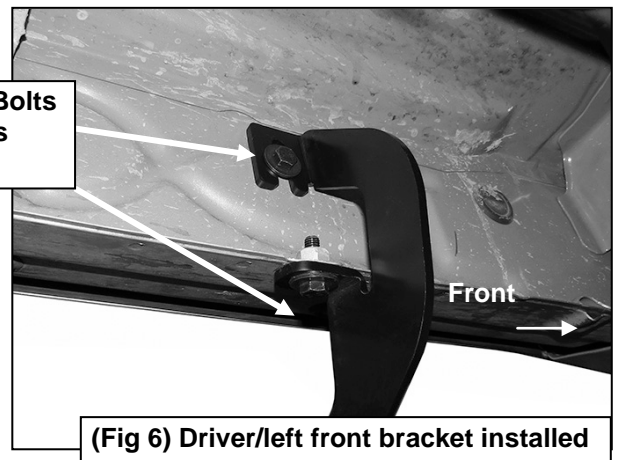

(Fig 6) Driver/left front bracket installed

iRunning Board Installation Instruction

Rev. 20170601

Application: For 07-17 Chevy/GMC Silverado/Sierra Regular Cab

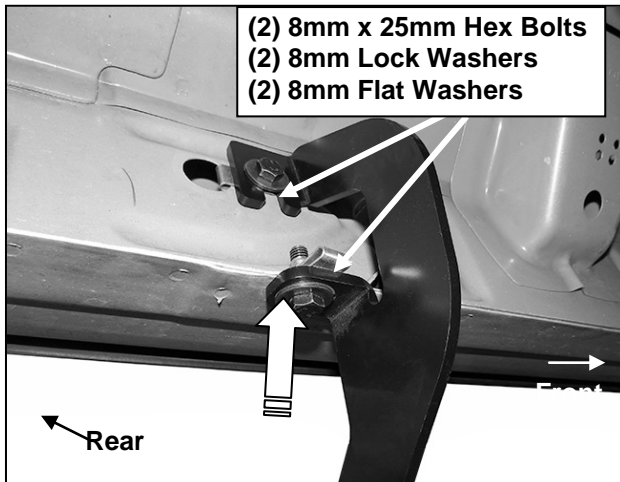

(Fig 7) Driver/left rear bracket installed

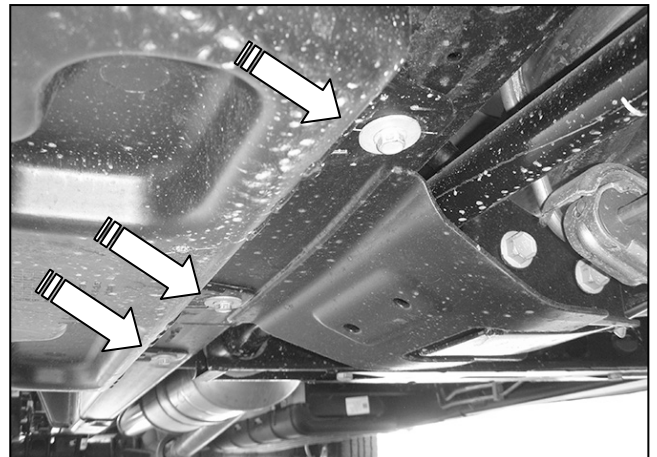

(Fig 8) 07-16 Passenger side front pictured with DEF tank cover. Remove (3) hex bolts to remove cover

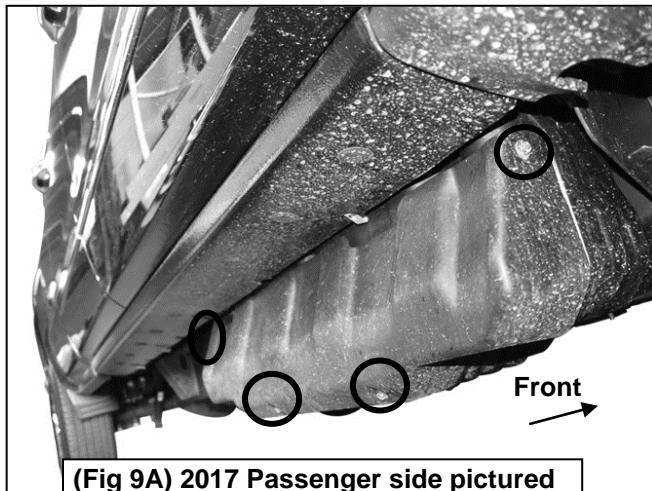

(Fig 9A) 2017 Passenger side pictured with DEF plastic tank cover. Remove (4) hex bolts to remove plastic cover

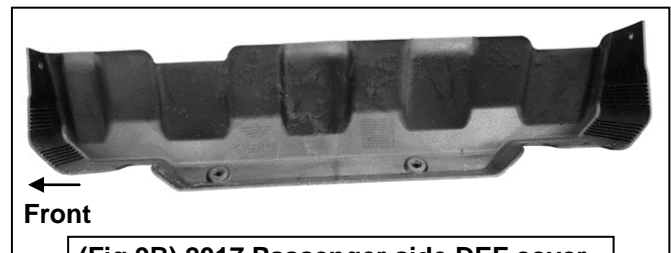

(Fig 9B) 2017 Passenger side DEF cover

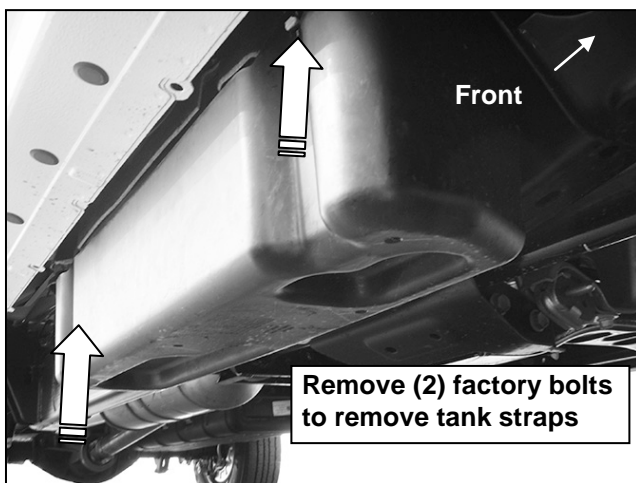

(Fig 10) 07-16 Passenger side DEF tank and cover

iRunning Board Installation Instruction

Rev. 20170601

Application: For 07-17 Chevy/GMC Silverado/Sierra Regular Cab

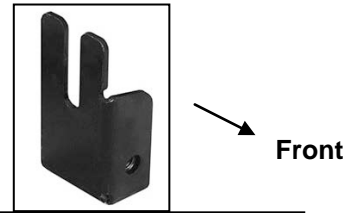

(Fig 11) Passenger/right Front Upper Bracket (all models)



(Fig 13) 8mm x 35mm Bolt Plate

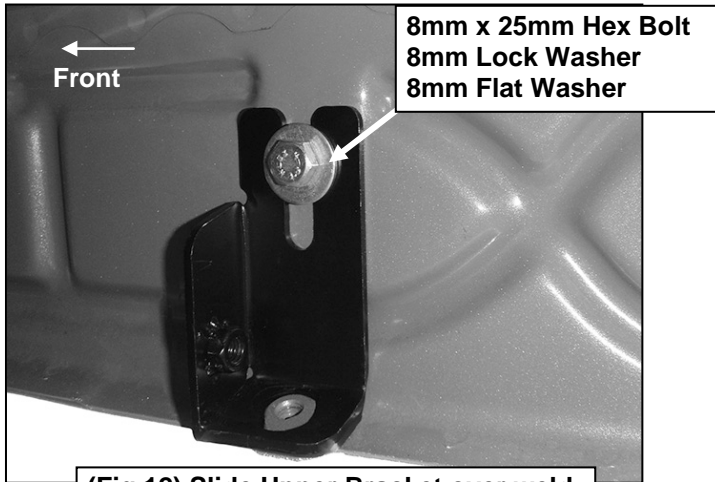

(Fig 12) Slide Upper Bracket over weld nut if equipped-also see Figure 2

Passenger/right Side Installation Pictured

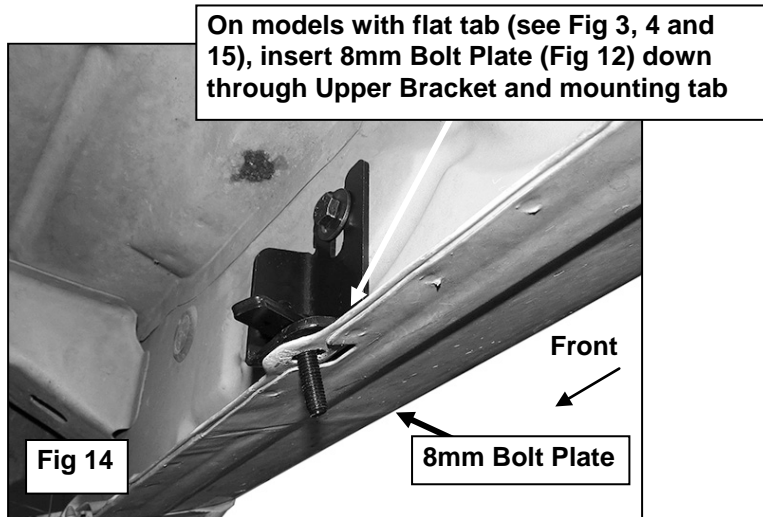

Passenger/right Side Installation Pictured

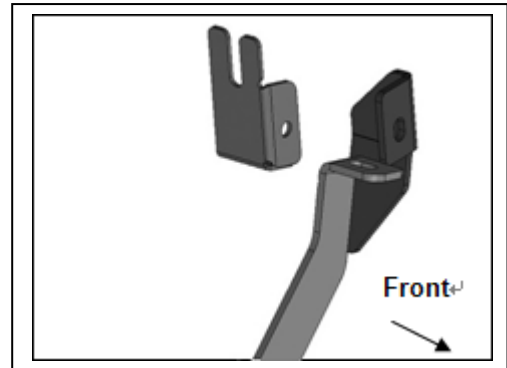

(Fig 15) Passenger/right Front Lower Bracket (all models)

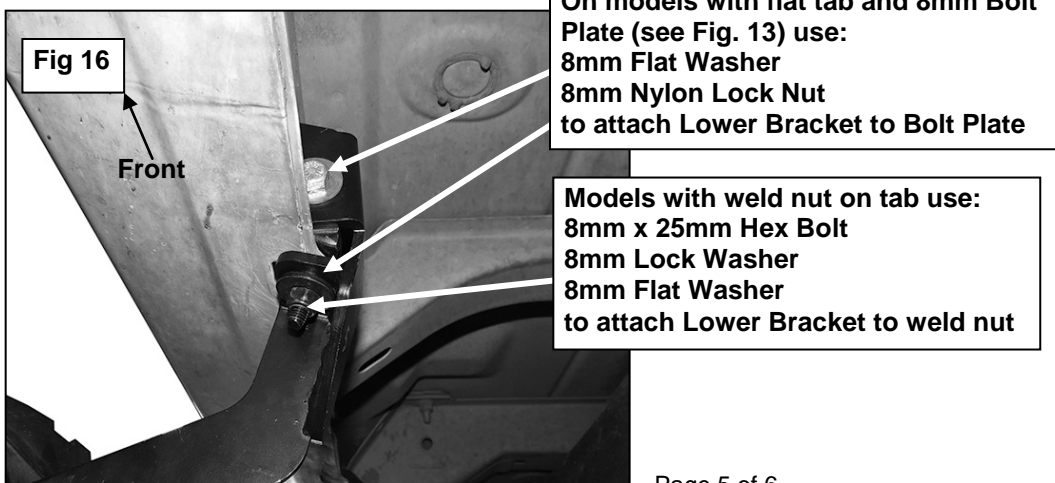

iRunning Board Installation Instruction

Rev. 20170601

Application: For 07-17 Chevy/GMC Silverado/Sierra Regular Cab

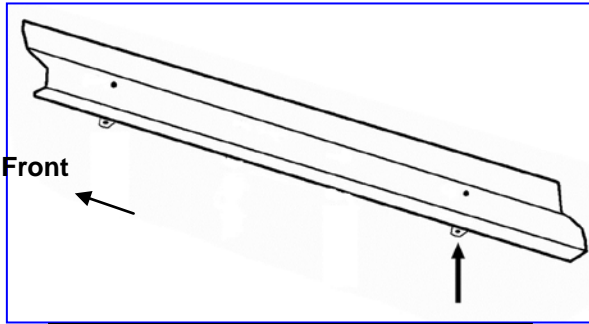

(Fig 17) Passenger side Rear bracket location from back of body

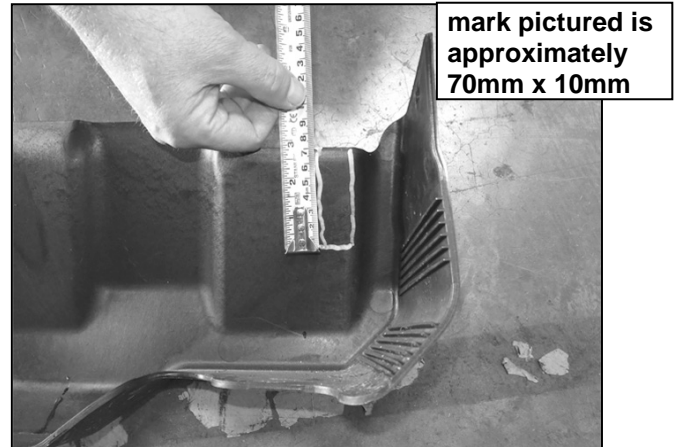

(Fig 18) 2017 Passenger side DEF cover marked for trimming

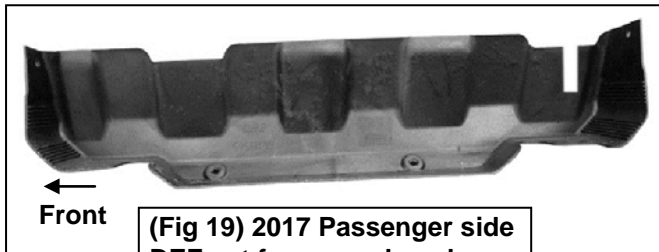

(Fig 19) 2017 Passenger side DEF cut for example only

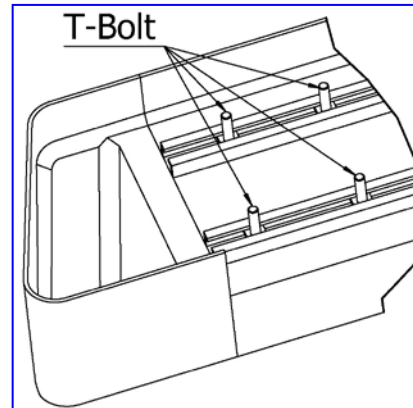

(Fig 20) Slip 6mm T-bolts into the bottom channel



Complete Installation

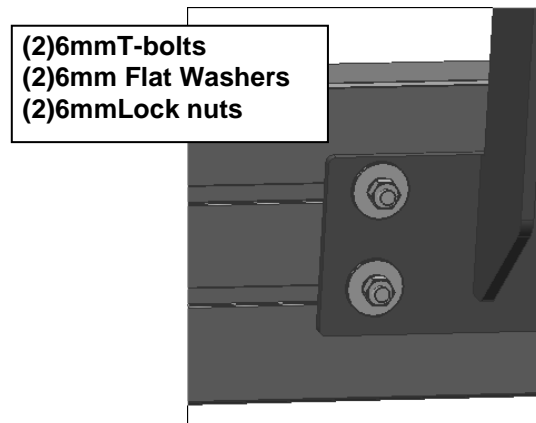

(Fig 21) Passenger/right bracket installed