

iRunning Board Installation Instructio

**Application: For 2004-2006 Chevy Trailblazer EXT /2002-2006 GMC Envoy XL/XUV/
(Excl. Vehicles With Cladding)**

Rev:20181201

PARTS LIST:

Item	QTY	Description	Item	QTY	Description
#01	1	Driver/Left Sidebar	#07	16	M8 Lock Washers
#02	1	Passenger/Right Sidebar	#08	20	M8 Flat Washers
#03	2	Driver/Left Mounting Brackets(DFM)	#09	4	M8 Hex Nuts
#04	2	Passenger/Right Mounting Brackets(PFM)	#10	16	M6 T- Bolts
#05	4	"L" Support Brackets(DFS)	#11	16	M6 Flat Washers
#06	16	M8 x 30mm Hex Bolts	#12	16	M6 Nylon Lock Nuts



PFM



DFS



DFM

INSTALLATION INSTRUCTION:

REMOVE CONTENTS FROM BOX. VERIFY ALL PARTS ARE PRESENT. READ INSTRUCTIONS CAREFULLY BEFORE STARTING INSTALLATION.

1. Start installation on the passenger side front of the vehicle. Locate the (2) factory threaded holes in the side of the body panel and the (2) lower threaded holes near the pinch weld, **(Figure 1)**. Select (1) passenger side Mounting Bracket. Bolt the Bracket to the (2) upper threaded holes with (2) M8 x 30mm Hex Bolts, (2) M8 Lock Washers and (2) M8 Flat Washers, **(Figure 2)**. Do not tighten hardware at this time.
2. Next, select (1) "L" shaped Support Bracket. Bolt the short end of the Support Bracket to the forward threaded hole near the pinch weld with (1) M8 x 30mm Hex Bolt, (1) M8 Lock Washer and (1) M8 Flat Washer, **(Figure 3)**. Line up the remaining hole in the Support Bracket with the slot in the Mounting Bracket. Bolt the Support Bracket to the Mounting Bracket with (1) M8 x 30mm Hex Bolt, (1) M8 Lock Washer, (2) M8 Large Flat Washers and (1) M8 Hex Nut. Do not tighten hardware at this time.
3. Repeat **Steps 1-2** for the passenger side rear Mounting Bracket installation.
4. Once all (2) Brackets have been installed, Select a Running Board. Slip (8) M6 T-Bolts into each bottom channel **(Figure 4)**. Carefully position the passenger Sidebar onto the Mounting Brackets. Bolt the Sidebar to the Mounting Brackets with the included (4) M6 T- Bolts, (4) M6 Flat Washers and (4) M6 Nylon Lock Nuts, **(Figure 5)**.
5. Level and adjust the Sidebar properly and tighten all hardware at this time. **NOTE: Torque all M6 nylon lock nuts to 7 lb-ft.**
6. Repeat **Steps 1-5** for driver Sidebar installation.
7. Do periodic inspections to the installation to make sure that all hardware is secure and tight.

To protect your investment, wax this product after installing. Regular waxing is recommended to add a protective layer over the finish. Do not use any type of polish or wax that may contain abrasives that could damage the finish.

iRunning Board Installation Instructio

**Application: For 2004-2006 Chevy Trailblazer EXT /2002-2006 GMC Envoy XL/XUV/
(Excl. Vehicles With Cladding)**

Rev:20181201

For Polished Finishes: Aluminum polish may be used to polish small scratches and scuffs on the finish. Mild soap may be used also to clean the Running Board.

For black finishes: Mild soap may be used to clean the Running Board.

Passenger Side Mounting Brackets Shows

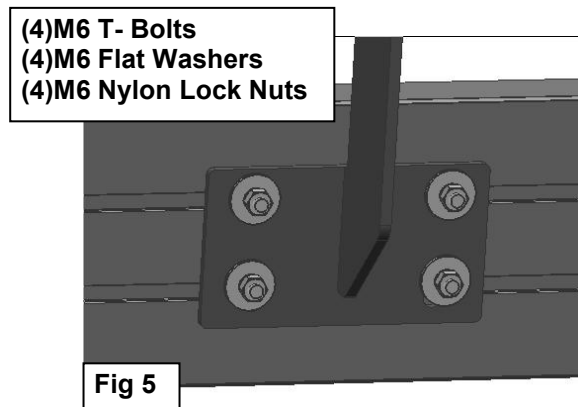
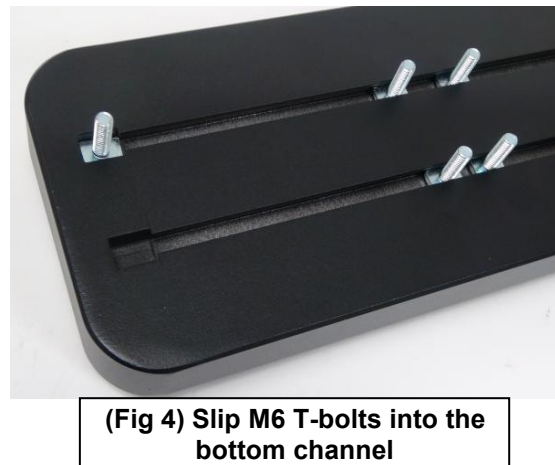
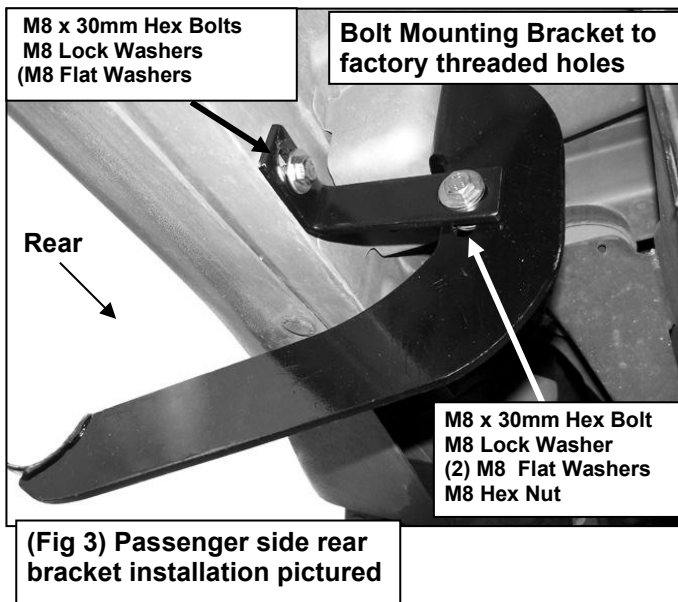
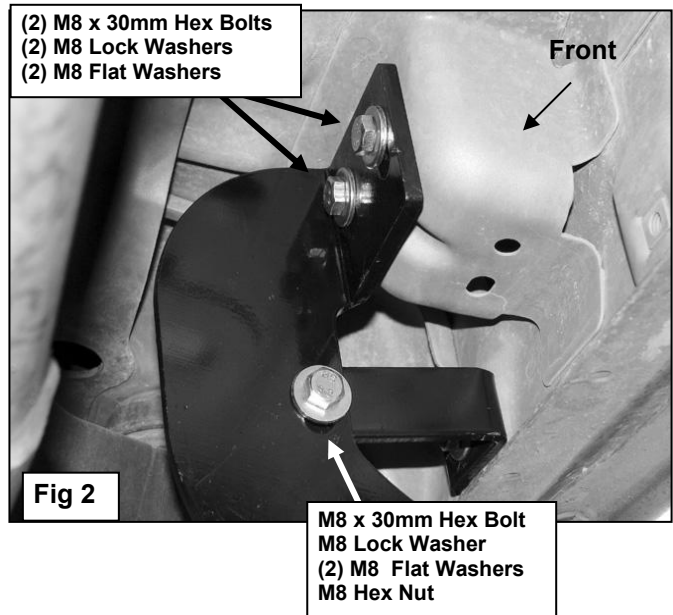
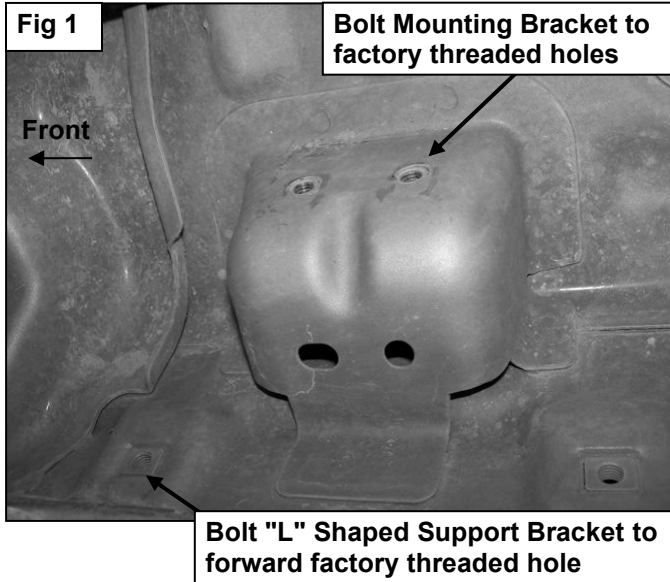

***Pictures are for reference only, actual brackets & bars may be a little different ***