

INSTALLATION INSTRUCTIONS

SBX-5006 Standalone mounting base with risers for SBX-1000 series Drawers in 2020 Interceptor Utility

TOOLS REQUIRED:

Standard socket set

Standard wrench set

Phillips screwdriver

PARTS and MOUNTING HARDWARE:

<u>QTY</u>	<u>DESCRIPTION</u>	<u>PART#</u>
1	Mounting base	CM010159
1	DS upper mounting bracket	CM010328
1	PS upper mounting bracket	CM010327
1	DS lower mounting bracket	CM009683
1	PS lower mounting bracket	CM009682
1	Forward block off plate	CM010385
6	10-32 x 1/2" Machine screws	GSM33118
6	#10 Flat washers	GSM31003
2	U-bolt (with nuts)	GSM20406
4	1/4" Serrated nut	GSM30023
4	5/16" x 3/4" Thread forming screw	GSM32038
4	5/16" x 1" bolt	GSM33012
8	5/16" Split lock washer	GSM31027
8	5/16" Flat washer	GSM31006
2	3/8" x 1" Hex bolt	GSM33028
2	3/8" Nylock nut	GSM30018
4	3/8" Flat washer	GSM31144

Always!

- Read all instructions before installing any Havis, Inc. products.
- Check for obstructions (Wires, brake lines, fuel tank, etc.) before drilling any holes!
 - Use hardware provided with install kit

SBX-5006

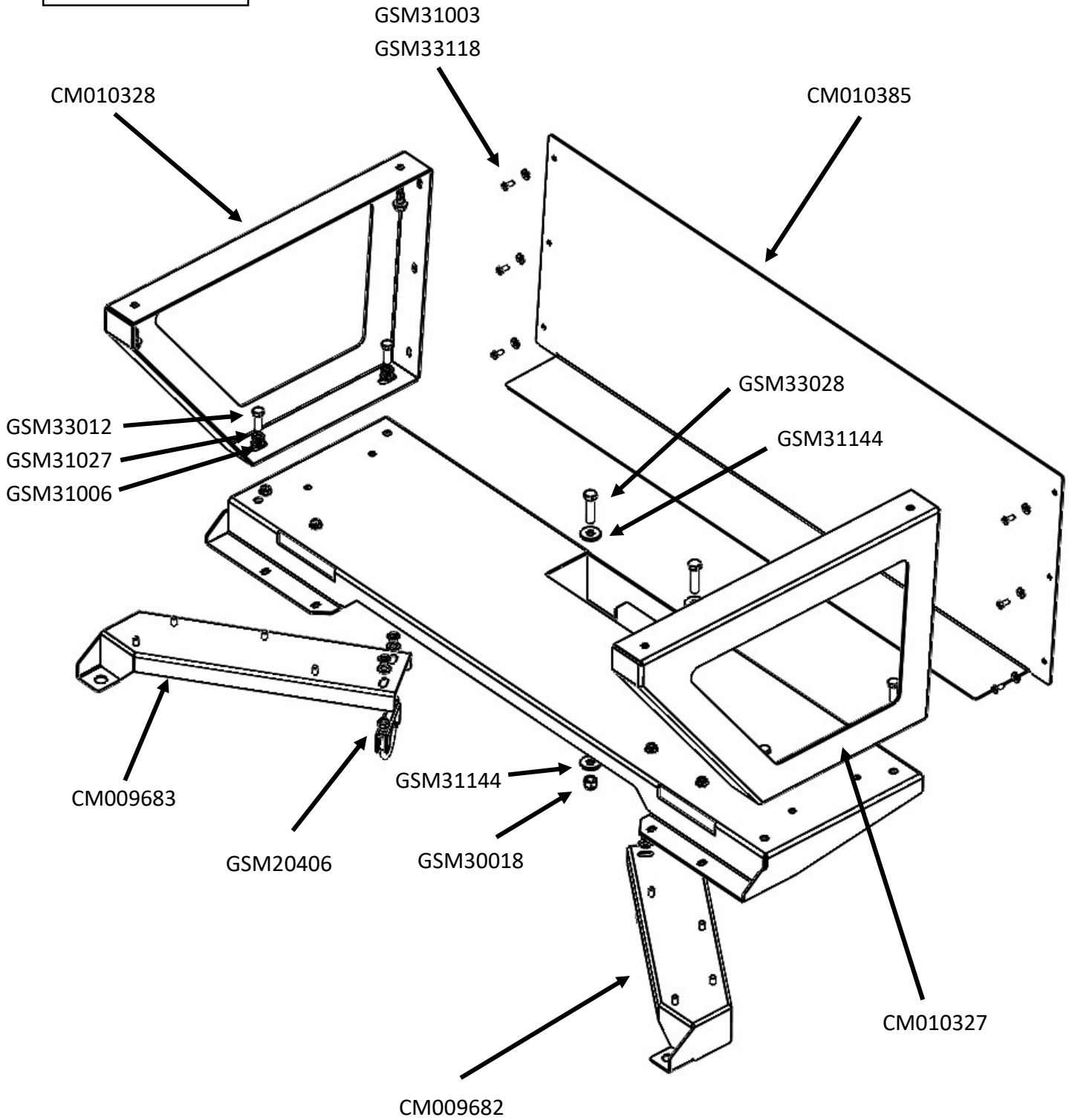



Remove both sections of the OEM trunk floor.

T-55 Torx socket



Remove rear bolt from OEM cross brace and install lower mounting bracket re-using OEM bolt.

Repeat for passenger side



Attach other end of lower support bracket with supplied U-bolt, flat washers, lock washers and nuts.

Repeat for other side



Place mounting base in the vehicle and attach to studs using (4) 1/4" serrated nuts.



Attach forward section of mounting base to OEM cross brace using (2) 3/8" x 1" bolts, washers, and nylock nuts.



Place rear section of factory floor back in vehicle.

This can also be placed back in vehicle at end of installation if desired.



Attach upper mounting brackets to the bottom of the SBX box using (4) 5/16" x 3/4" thread forming bolts. *Run bolts in and out once prior to attaching bracket to start threads.*



Place drawer assembly into vehicle and line up to the mounting points in the mounting base. Attach using (4) 5/16" x 1" bolts, flat washers and split lock washers.



Attach block off plate to forward section of risers using (6) 10-32 x 1/2" screws and washers.

Block off plate not shown.

SBX-5006_INST_1-20