

<THESE INSTRUCTIONS MUST BE GIVEN TO THE END USER>



B&W Trailer Hitches
 1216 Hawaii Rd / PO Box 186
 Humboldt, KS 66748
 P:800.248.6564
 F:620.869.9031

Call or Email us for
 Installation Support
 hitches@turnoverball.com
 bwtrailerhitches.com

See Limited Lifetime Warranty at
bwtrailerhitches.com/warranty

Turnoverball® Gooseneck Hitch Installation Instructions

MODEL 1123

2023 Ford F250 & F350 trucks, and Ford F450 trucks with Factory Installed Bed.

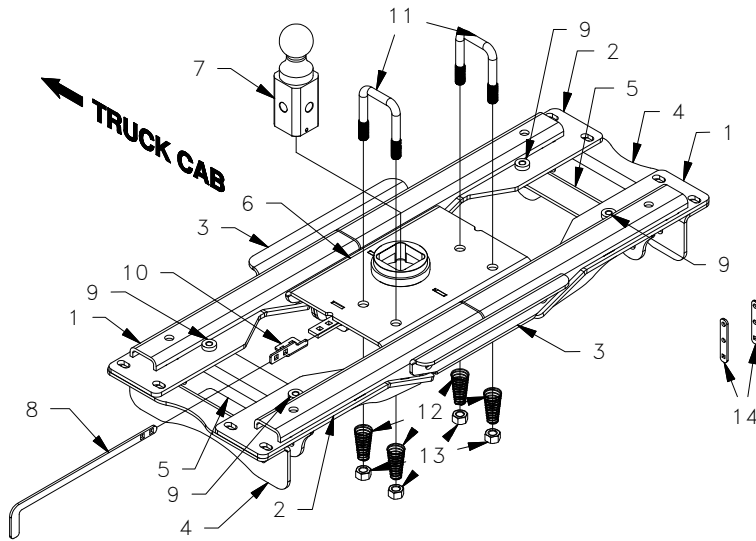

Mounting Kit Box (GNRM1123)		
ITEM	DESCRIPTION	QTY
1	Cross Member A	2
2	Cross Member B	2
3	Cross Member Brace	2

Center Box (GNRC823)		
ITEM	DESCRIPTION	QTY
4	Outer Side Plate	2
5	Inner Side Plate	2
6	Center Section	1
7	2-5/16" Ball	1
8	Latch Pin Handle	1

Hardware Bolt Bags 1 & 2		
ITEM	DESCRIPTION	QTY
9	1/2" Threaded Bushing	4
	1/2" Flange Bolt w/ Thread Locker	4
	1/2" x 1-1/2" Cap Screw	12
	1/2" x 1-1/4" Carriage Bolt	4
	1/2" Flat Washer	24
	1/2" Lock Washer	16
	1/2" Finish Nut	16
	5/8" x 4-1/2" Cap Screw	8
	5/8" Flat Washer	12
	5/8" Lock Washer	8
	5/8" Finish Nut	8

Hardware Bolt Bag 3		
ITEM	DESCRIPTION	QTY
10	Latch Pin Handle Bracket	1
11	5/8" x 2-1/2" x 4" U-Bolt	2
12	Conical Spring	4
13	5/8" Center Lock Nut	4
14	Exhaust Bracket	2
	5/16" x 3/4" Carriage Bolt	4
	5/16" Flange Nut	4
	1/4" x 3/4" Carriage Bolt	2
	1/4" Flange Nut	2

⚠ WARNING

Failure to comply with the safety information in these instructions could result in serious injury or death.

- ⚠ Read all installation and operating instructions along with all labels before using this product.
- ⚠ Adding components such as a Turnoverball hitch to the chassis of any vehicle can be hazardous. There is potential for unexpected combustion of fuel, electric shock, burns, shifting or falling of unstable vehicle, damage to vehicle, injury from tool usage and many other hazards. This installation must be completed by someone who is aware of the hazards involved. This person must be knowledgeable of proper safety procedures for a vehicle modification of this nature, and for usage of the equipment required to perform the installation.
- ⚠ Without proper knowledge, towing can be a dangerous activity. Understand all the risks involved with towing before proceeding. For information on towing safety, see "**The Trailer Handbook: A Guide to Understanding Trailer and Towing Safety**" from the National Association of Trailer Manufacturers, www.NATM.com and your trailer manufacturer's owner's manual.
- ⚠ Do not exceed tow or tongue rating of coupler, tow or tongue rating of hitch, or tow or weight ratings of truck or trailer. See vehicle and trailer manufacturer information for ratings. Exceeding these ratings may cause damage to towing components or loss of attachment between the trailer and truck.
- ⚠ Do not modify this product in any manner. Doing so could alter its integrity and lead to a loss of attachment between the trailer and the tow vehicle.
- ⚠ Additional caution must be used when towing a wedge car trailer. Towing stability greatly depends on keeping the center of gravity as low as possible. Load heavy cars over the axles. Never tow with a single car on the front of the trailer. When towing a wedge car trailer, never exceed speeds that are reasonable for the roadway conditions (e.g. turns, going around a curve, etc.). Failure to account for proper trailer center of gravity and speeds that are reasonable for the roadway conditions may cause damage to the truck, trailer, towing components, and loss of attachment between the truck and trailer.
- ⚠ This product was designed to fit vehicles in their original, "as manufactured" condition. Compatibility with vehicles having replacement parts, or other modifications is not guaranteed. Inspect vehicle for modifications before installation of this product.
- ⚠ The Turnoverball hitch comes equipped with a 2-5/16" ball. Trailers towed with the ball provided must have a 2-5/16" coupler. Towing with a larger coupler could cause loss of attachment between the trailer and the tow vehicle.
- ⚠ A visual inspection of the hitch should be performed before each time you tow. Regularly check that all pinned connections are secure, and that all bolted connections are at the correct torque specification. Check for cracks or damage to the hitch. Do not tow with the hitch if cracks or damage outside of normal wear is found. Towing with a hitch that has cracks or damage could result in damage to the tow vehicle, trailer, towing components or loss of attachment between the tow vehicle and trailer.

PREPARE TO INSTALL

NOTE: Remove all parts from the packaging and familiarize yourself with all the parts and tools required. Use the parts list on the front page to verify that all parts and hardware are present.

Installation of the Turnoverball hitch requires several common tools and a few specialized tools. Below is a listing of equipment used during a typical installation.

TOOLS REQUIRED

- Impact wrench or ratchet with 10mm, 7/16", 1/2", 3/4", & 15/16" sockets.
- 1/2", 3/4" & 15/16" Box end wrench
- Marking tool (pencil or permanent marker)
- 4" hole saw
- Drill with 11/16" bit
- Ear protection
- Pry bar
- Lifting device
- Flashlight
- Eye protection
- Torque wrench
- Tape measure
- Pilot hole bit

1. **Determine cab clearance.** The Turnoverball hitch is designed so that the ball can be inverted and stored below the surface of the truck bed while not in use. The ball location is determined by this design feature and the truck geometry. Measure the trailers to be towed with this hitch to be sure that the location of the 2-5/16" ball listed in Step 5 will provide ample turning clearance between the nose of the trailers and the cab of the truck.

WARNING: Cab clearance on short bed trucks is very limited when towing certain trailers. Failure to ensure that there will be adequate clearance, may result in significant property damage, or serious injury.

2. **Remove the spare tire.** Following the vehicle manufacturer's instructions, remove the spare tire. This will provide easier access to the area where the hitch will be installed.
3. **Position the vehicle.** Installation of the hitch requires the installer to be under the truck bed in the area of the rear axle. Lifting the vehicle makes this area more accessible to the installer, and improves the installation process.

WARNING: Lift vehicle using only equipment designed for lifting and positioning vehicles for service. Failure to do so may result in property damage, serious injury, or death.

4. **Prepare a lifting device.** The purpose of the device is to safely hold the hitch in position during part of the installation. See Figure A1 for an example. A simple mechanical lifting device is available for purchase from B&W.

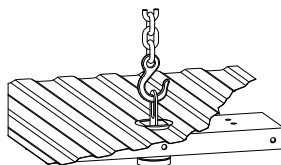

Figure A1.

WARNING: Turnoverball hitch components are heavy and may be cumbersome to handle. Failure to use proper lifting techniques and caution when handling these items could result in serious injury.

5. **Mark the 4" hole location.** In most installations a dimple in the bed will be used to drill the 4" hole. If the dimple is hard to see due to a spray in bed liner it can be located under the truck bed. If the dimple cannot be found, the 4" hole location can be located manually. Using a tape measure hooked over the rear edge of the bed (at tailgate end), measure the location for the hole as shown in Figure A2. Next, locate the center of the bed by measuring the distance between the wheel wells and dividing by two. The center of the hole will be at the intersection of the center of the bed and the first distance measured.

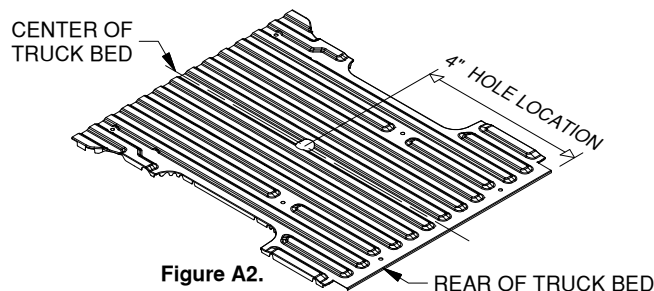

Figure A2.

4" HOLE LOCATION

8' LONG BED AND SHORT BED (BED LESS THAN 8' LONG): USE DIMPLE IN BED OR 45-3/4"

IMPORTANT: The hitch is designed to install only at the described location. Failure to place the 4" hole precisely may result in added difficulty during installation or property damage.

IMPORTANT: If the bed is equipped with a plastic bed liner, the hole may be cut through both the liner and the bed. However, the center of truck bed may be more difficult to locate, and the mark may be harder to hit if the liner slides or moves. Failure to cut the hole in the correct location may adversely affect the install and may result in property damage.

IMPORTANT: If your truck has a spray-in bed liner you will need to take this into account when you are measuring, and add the thickness of the applied liner that has been sprayed over the end of the bed.

6. **Cut the 4" diameter hole.** Cut the hole in the marked location using a 4" hole saw or by marking out the 4" hole and using a saber saw equipped with a metal cutting blade. Remove any burrs created while cutting hole.

NOTICE: Galvanic corrosion information.

When installing the GNRK 1123, B&W recommends that the installer references Ford SVE Bulletin Q-222R1 for attaching accessories to aluminum panels and structure. It can be found at fordbbas.com/bulletins.

⚠ WARNING: Most trucks have fuel lines, brake lines, electrical wires or other vehicle systems located along the frame rails or in the general area where B&W Turnoverball hitches install. Carefully examine the locations of these systems before installation. Make certain that these are not damaged during positioning hitch components, drilling holes, or tightening fasteners. Damage to these systems may result in property damage, serious injury, or death.

INSTALL EXHAUST BRACKETS DIESEL TRUCKS ONLY

- 1. Lower the exhaust.** To install the hitch on a diesel truck the exhaust will need to be lowered. Locate the two exhaust brackets, 1/4" carriage bolts, and 1/4" flange nuts. Remove the four bolts holding the exhaust hanger bracket as shown in Figure A2. Pull down on the exhaust and place an exhaust bracket on the outside of the hanger bracket. Reattach the exhaust bracket one hole lower as shown in Figure A3. Use the 1/4" hardware on the lowest hole with the carriage bolts installed so the nuts attach on the outside of the brackets. Install the second exhaust bracket on the other side of the frame.

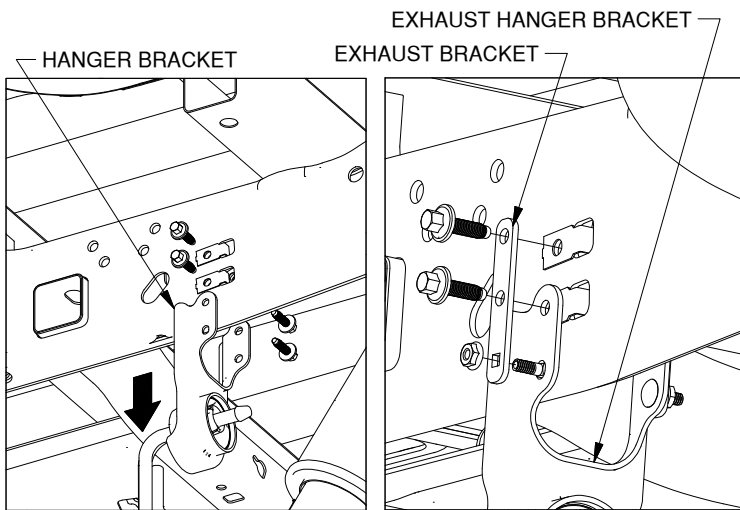

Figure A2: View looking inside passenger side wheel well

Figure A3: View looking inside passenger side wheel well

INSTALL SIDE PLATES

- 1. Side plates.** Each hitch install will require a set of inner side plates and a set of outer side plates. Some truck models have inner side plates welded to the frame at the factory. Others do not. If your truck has the inner side plates installed at the factory you may discard the inner side plates provided with this kit and only install the outer side plates in Step 3.

- 2. Relocate wiring.** Locate the wiring harness bracket under the bed and over the axle attached to the driver side frame, see Figure B1. On top of the bracket, there are two large wiring plugs. Remove the plugs from the bracket by pulling the plastic ratchet connector out of the bracket. Move both plugs below the bracket. Reattach the plug on the outer edge of the bracket to the underside of the bracket. If the frame has inside side plates welded to it, push the large wiring bundle beneath the top edge of the side plate if it is above the side plates.

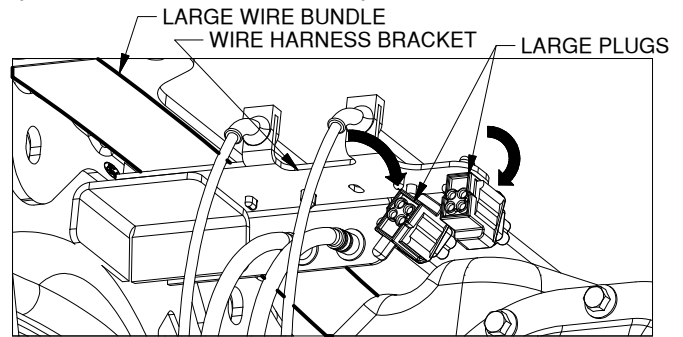

Figure B1: View looking up under the bed.

- 3. Install side plates.** Locate the outer, and if needed, the inner side plates. Install the side plates as shown in Figures B2 & B3, so that there is a side plate on the inside and outside of each frame member. Attach the side plates to the frame four places using a 5/8" x 4-1/2" cap screw, two flat washers, lock washer, and nut. Fasten hardware tight enough to hold the side plates against the frame but loose enough that they can still move up and down. Ensure that the large wiring bundle, shown in Figure B1, is under the driver side inner side plate.

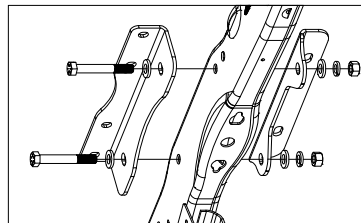

Figure B2: Driver side plates

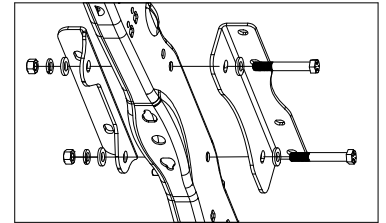

Figure B3: Passenger side plates

INSTALL CROSS MEMBERS

- 1. Install threaded bushings.** Install a 1/2" threaded bushing into each of the four cross members. Align each bushing into the "D" shaped hole on top of each cross member and tap or press the bushing into the hole. The rim of the bushing must be flat against the cross member, see Figure C1. Do not damage threads.

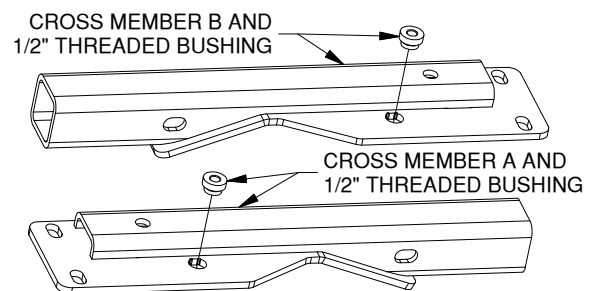

Figure C1: Cross members

- Place cross members.** Locate the two A and B cross members and the four 1/2" flange bolts with a thread locker. Pass each of the cross members up and over the inside side plates, as shown in Figure C2. Attach each cross member to the inner side plate with the 1/2" flange bolts. Loosely attach the flange bolts by a few threads only.

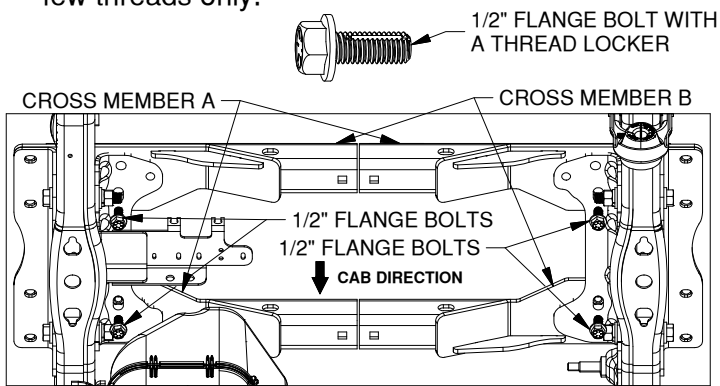

Figure C2: View looking up under the bed.

- Place carriage bolts into cross members.** Move the cross members so that the open end of the tube is accessible. Place a 1/2" carriage bolt into each of the four cross members, as shown in Figure C3.

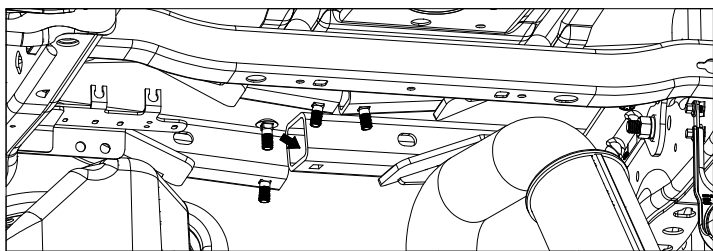

Figure C3: View looking up under the bed.

- Place the cross member brace.** The two front cross members will be joined by a cross member brace. Locate a cross member brace and two 1/2" flat washers, lock washers, and finish nuts. Hold the two front cross members up so that the carriage bolts are in line with each other. Place the cross member brace over two 1/2" carriage bolts, as shown in Figure C4. The brace will need to be moved around the protruding edges of the cross members as the bolts are inserted into the brace. Attach the brace with the 1/2" hardware. Leave the the hardware loose at this time.

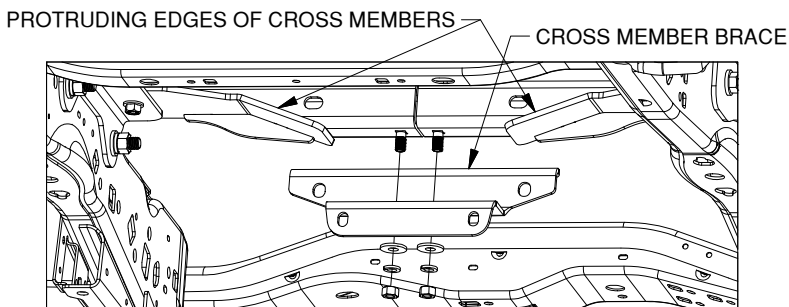

Figure C4: View looking up under the bed.

- Secure the cross member brace.** Locate two 5/8" x 4-1/2" cap screws, 5/8" flat washers, and finish nuts. Temporarily install the 5/8" hardware into the large holes in the cross members and the brace as shown in Figure C5. Tighten the 5/8" cap screws enough to ensure that the brace and the cross member tubes are flush. Tighten the two 1/2" nuts on the bottom of the cross member brace until the lock washers start to flatten. Remove the 5/8" cap screws and hardware.

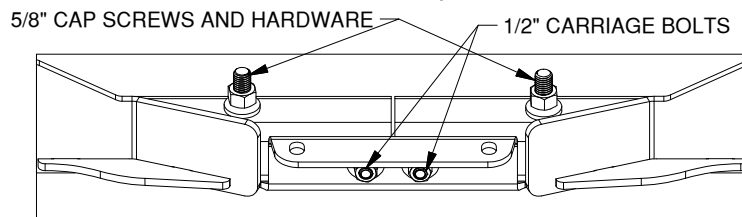

Figure C5: View looking up under the bed.

INSTALL CENTER SECTION

- Install latch pin handle bracket.** Locate the latch pin handle bracket, two 5/16" x 3/4" carriage bolts, and two 5/16" flange nuts. Pull the handle out all the way until it stops then slide it forward to keep it in place. Install the latch pin handle bracket in the orientation shown in Figure D1. Attach the bracket using the 5/16" hardware. Align the bracket with the latch pin. The carriage bolts must be installed from the bottom up as shown. Torque the nuts to 30 ft. lbs.

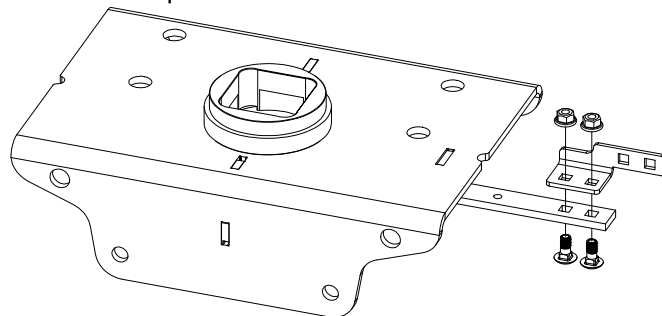

Figure D1: Center section with latch pin pulled out.

- Position center section.** Place a 5/8" x 4-1/2" cap screw with a 5/8" washer into the driver side cross member so the threaded side is flush with the outside of the cross member. With the latching mechanism on the drive side, raise the center section up under the 4" hole, see Figure D2. Align the hole in the front of the center section with the 5/8" cap screw and push the cap screw through the center section. Loosely secure the cap screw with a 5/8" lock washer and nut.

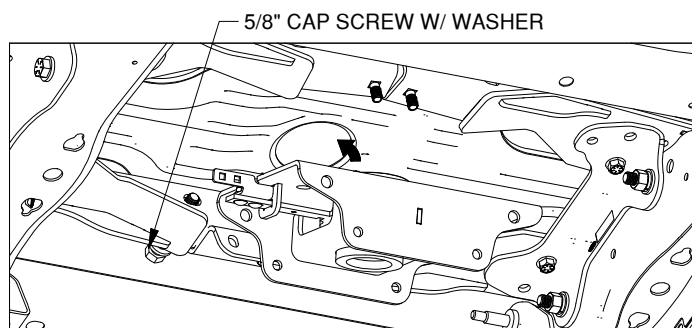

Figure D2: View looking up under the truck bed.

- 3. Place second center section cap screw.** Place a 5/8" x 4-1/2" cap screw into the hole on the passenger side of the center section from the inside of the center section toward the front of the truck, as shown in Figure D3. Loosely secure the cap screw with a 5/8" flat washer, lock washer, and nut.

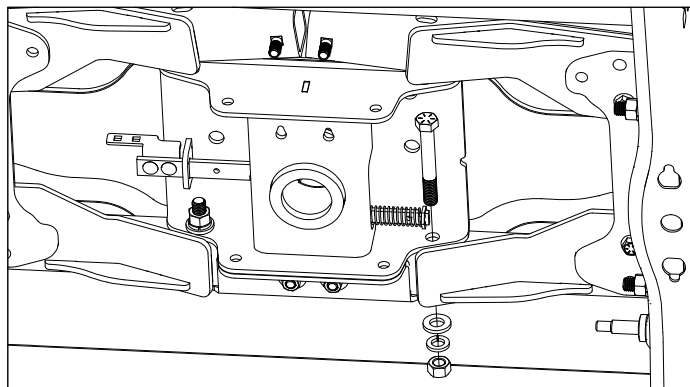

Figure D3: View looking up under the truck bed.

- 4. Place the second cross member brace.** Locate a cross member brace and two 1/2" flat washers, lock washers, and finish nuts. Hold the two rear cross members up so that the carriage bolts are in line with each other. Place the cross member brace over two 1/2" carriage bolts, as shown in Figure D4. Attach the brace with the 1/2" hardware. Push the brace tight against the cross members, then tighten the 1/2" nuts on the carriage bolts until the lock washers start to flatten.

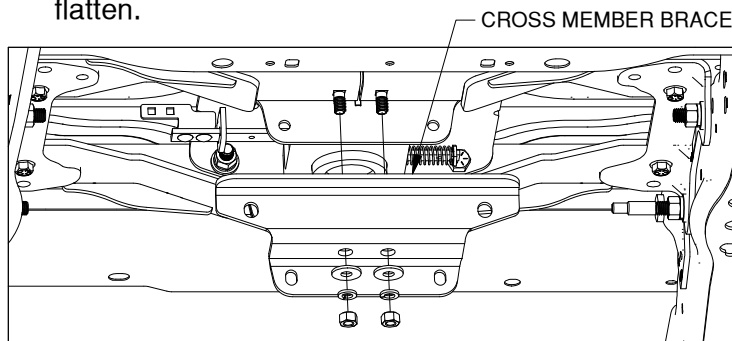

Figure D4: View looking up under the truck bed.

- 5. Position center section.** Place two 5/8" x 4-1/2" cap screws into the two large holes in the rear of the center through the two rear cross members, as shown in Figure D5. Loosely secure the cap screws with a 5/8" flat washer, lock washer, and nut.

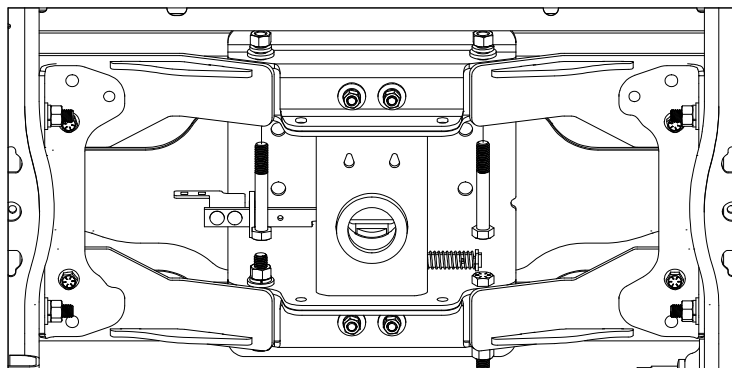

Figure D5: View looking up under the truck bed.

- 6. Install center section bottom cap screws.** Place four 1/2" x 1-1/2" cap screws into the four holes in the bottom of the center through the two cross member braces, as shown in Figure D6. Loosely secure the cap screws with a 1/2" flat washer, lock washer and nut.

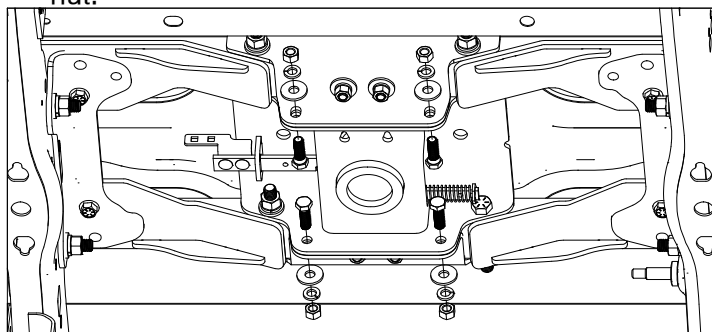

Figure D6: View looking up under the truck bed.

- 7. Install outside side plate hardware.** Inside each wheel well, place four 1/2" x 1-1/2" cap screws into the four holes that connect the cross members to the outside side plates, as shown in Figure D7. Due to the limited clearance under the bed stiffener, one of the cap screws will need to be installed from the bottom up. Loosely secure the cap screws with two 1/2" flat washers, a lock washer, and a nut. Repeat on the other side of the truck.

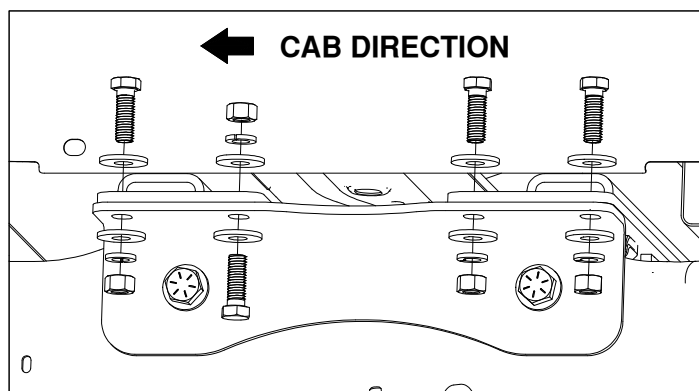

Figure D7: View looking into the driver side wheel well.

SECURE HITCH

NOTE: To ensure the correct positioning of hitch components, secure the hitch in the sequence provided below. Most components are currently installed loosely, expect components to shift and move until they are completely secure.

1. **Position the center section.** Attach a lifting device through the 4" hole and into the center section latch pin. Pull the center section up so that it is flat against the bottom of the truck bed. Do not deform the bed. Center the raised portion of the center section in the 4" hole.
2. **Tighten the four 5/8" cap screws in the center section.** Tighten the four 5/8" x 4-1/2" cap screws attaching the center section to the four cross members until the lock washers start to flatten. After tightening the cap screws double check that the raised portion of the center section is centered in the 4" hole.

IMPORTANT: The hitch must be square in the truck. If the latch pin is not parallel with the axle, certain accessories to the Turnoverball hitch will not be square with the truck.

3. **Square the center section.** The center section has two small notches on each side, see Figure E1. To properly align the center with the bed stiffener, compare the location of these notches with the grooves on the stiffener. Rotate the center and cross members until the notches in the center section are equally aligned on both sides with the stiffener.

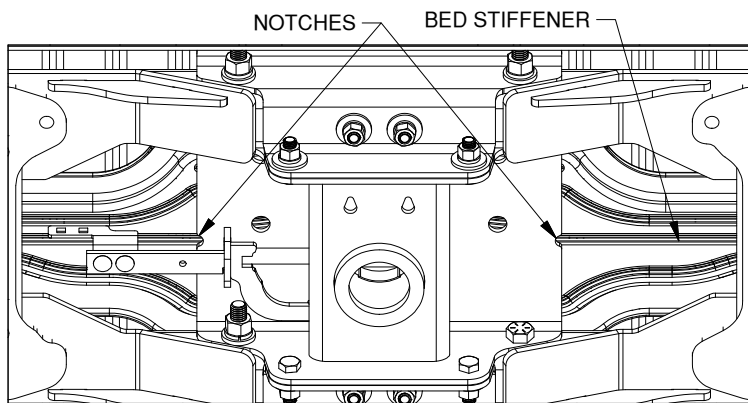

Figure E1: View looking up under the bed.

NOTE: Due to the installation method, the most effective practice for squaring the hitch is by referencing the center section only.

4. **Tighten the four 1/2" flange bolts with thread locker.** Tighten the four vertical 1/2" flange bolts. Tighten the bolts until the cross members are tightly secured against the inner side plates. If the inner side plates are not welded to the frame they should move up to meet the cross members. If the center section has shifted and is no longer centered or squared, loosen the four 1/2" flange bolts and adjust the hitch as needed.

5. **Tighten the eight 1/2" side plate cap screws.** Inside the wheel wells, tighten the eight 1/2" cap screws attaching the outside side plates to the cross members. Tighten the cap screws until the cross members are tightly secured against the outer side plates.
6. **Tighten the four 5/8" side plate cap screws.** Tighten the four 5/8" x 4-1/2" cap screws attaching the inner and outer side plates to the truck frame.
7. **Tighten the four 1/2" center section cap screws.** Tighten the four 1/2" cap screws attaching the cross member braces to the center section.
8. **Torque all hitch hardware.** Once hitch is in the correct position and all hardware is tight, torque the hitch bolts in the order outlined below, starting with the 5/8" cap screws in the center section, see Figure E2. Torque all 5/8" hardware to 150 ft. lbs. and all 1/2" hardware to 110 ft. lbs.

1st - The 5/8" cap screws attaching the center section to the cross members.

2nd - The four 1/2" carriage bolts attaching the cross member braces to the cross members.

3rd - The four 1/2" flange bolts attaching the inner side plates to the cross members.

4th - The eight 1/2" cap screws attaching the outer side plates to the cross members.

5th - The four 5/8" cap screws attaching the inner and outer side plates to the frame.

6th - The four 1/2" cap screws attaching the bottom of the center section to the cross member braces.

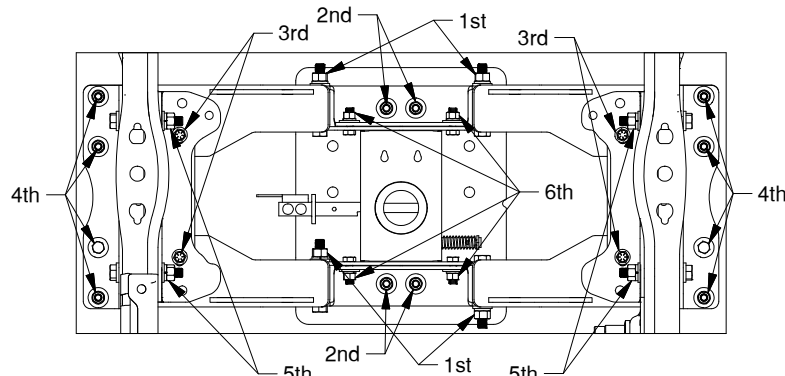

Figure E2: View looking up at hitch installation showing bolt torque sequence.

⚠ WARNING: Failure to follow the bolt tightening sequence may result in the hitch components being misaligned which could affect the performance of the hitch, or result in property damage, or serious injury.

9. **Remove the lifting device.** With the hitch torque sequence complete, remove the lifting device.

INSTALL LATCH PIN HANDLE

IMPORTANT: The latch pin will not function properly if handle is not installed correctly.

⚠ WARNING: If the latch pin becomes latched after being unlatched, it will forcefully return and may cause injury. Use caution when working under the center with the latch pin pulled out.

1. **Install handle.** With the handle pointing down, pass the handle under the driver side bed between the cross members, as shown in Figure F1. Under the bed, align the square holes in the handle with the holes in the latch pin handle bracket. Insert a 5/16" carriage bolt in each of the square holes in the handle and secure with a flange nut, see Figure F2. Torque the nuts to 30 ft. lbs.

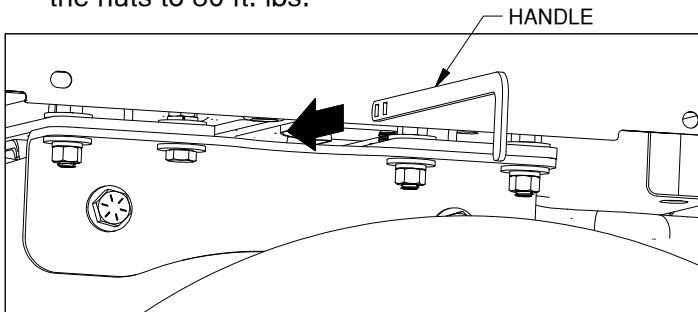

Figure F1: View looking into the driver side wheel well.

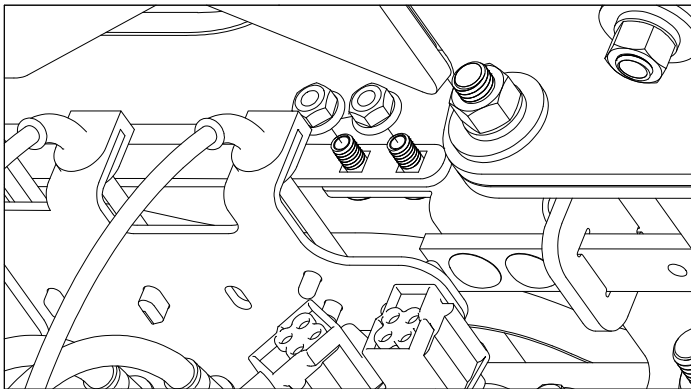

Figure F2: View looking up under the bed.

2. **Verify clearance.** The general area under the truck where the handle operates contains several brake lines, wires, plugs, and other objects. Cycle the latch pin with the handle attached and observe the travel path of the handle. Make sure that its travel path is clear. It may be necessary to relocate objects that interfere with the handle's operation. To operate the latch mechanism from the wheel well, pull the handle away from the truck frame and push toward the cab. This will hold the pin in the unlatched position. Move handle toward rear of truck to engage latch pin.
3. **Secure large wiring plug.** Secure the large wiring plug that was removed from the middle top of the wiring harness bracket in Step 2 of the INSTALL SIDE PLATES section. Use a wire tie or cable tie to secure it in place.

INSTALL SAFETY CHAIN U-BOLTS

1. **Drill holes.** From under the bed, using a drill and small drill bit, drill a pilot hole into each of the safety chain locations, shown in Figure G1. The pilot will have to drill through the the bed stiffener and the bed. From the top of the bed, drill each hole with a 11/16" drill bit. Drill the holes perpendicular to the surface of the bed. It is possible to drill the holes from under the bed if necessary.

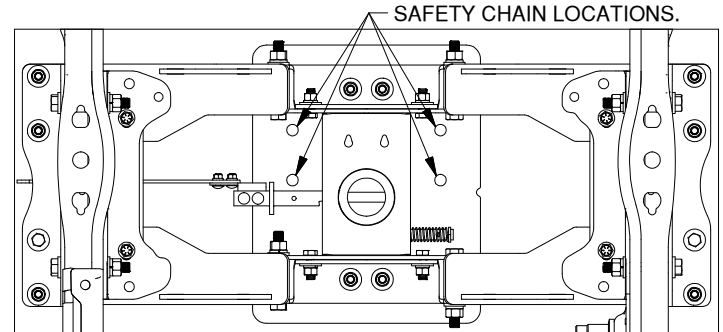

Figure G1: View looking up at hitch installation.

2. **Install U-bolts.** From the top side of the truck bed, drop a U-bolt in each set of holes.
3. **Add springs.** Place a conical spring over each leg of the U-bolts and secure with a 5/8" lock nut, see Figure G2. Tighten the lock nut until the nut is flush with the end of the U-bolt.

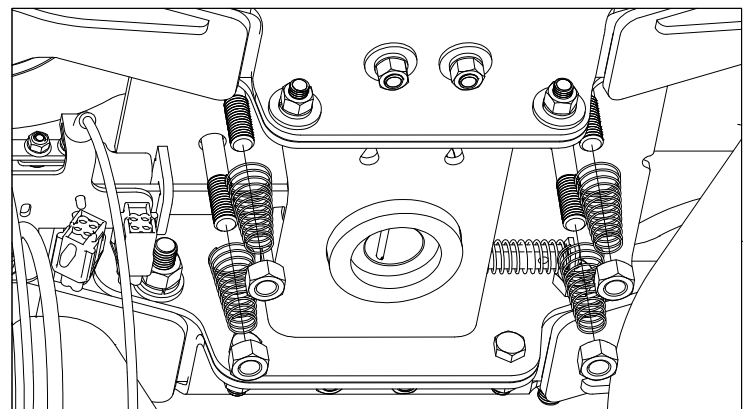



Figure G2: View looking up under the bed.

PREPARE FOR TOWING

1. **Replace spare tire.** If the spare tire was removed prior to installing the hitch, replace it at this time.
2. **Retract the pin.** Pull the handle out all the way until it stops then slide it toward the cab. The handle should stay in this position. The latch should only be put in this open position when inverting the 2-5/16" ball or installing a B&W towing accessory.

 **WARNING:** The handle operates in a very tight space within the wheel well of the truck. Use caution when operating the handle so that your hands and fingers do not get injured on the sharp edges of the truck, or by getting pinched against the frame due to the force of the spring loaded latch pin.

 **WARNING:** Operating the tow vehicle while the latch is in the open position may allow the handle to come into contact with the rear tire. This may damage the tire or the handle and could lead to serious injury or death.

3. **Lubricate 2-5/16" ball.** Apply a light coating of grease to the corners on the square shank of the 2-5/16" ball.
4. **Engage pin.** Move handle toward rear of truck until the handle retracts and engages the 2-5/16" ball.

 **WARNING:** When installed properly the latch pin will pass through the 2-5/16" ball and fully engage through both walls of the hitch receiver. Failure of the pin to engage the ball and hitch properly could result in a loss of attachment between the trailer and the tow vehicle.

 **WARNING:** Inverting the ball while hauling heavy loads may cause the ball to strike the truck's differential, drive line, or other components. Inspect the relationship between the ball and truck components to ensure the proper clearance. Failure to remove the ball when hauling heavy loads may result in property damage, injury or death. A cover to prevent debris from entering the socket while operating without the ball in place is available from B&W.

5. **Re-read front page.** Re-read all warnings on front page of these instructions. If you are not the end user, make sure that users of this product receive a copy of these instructions.