

Winch System Grille Guard

Installation Instructions

ET004

2019 - 2020 Chevrolet Silverado
 4500HD 5500HD 6500HD

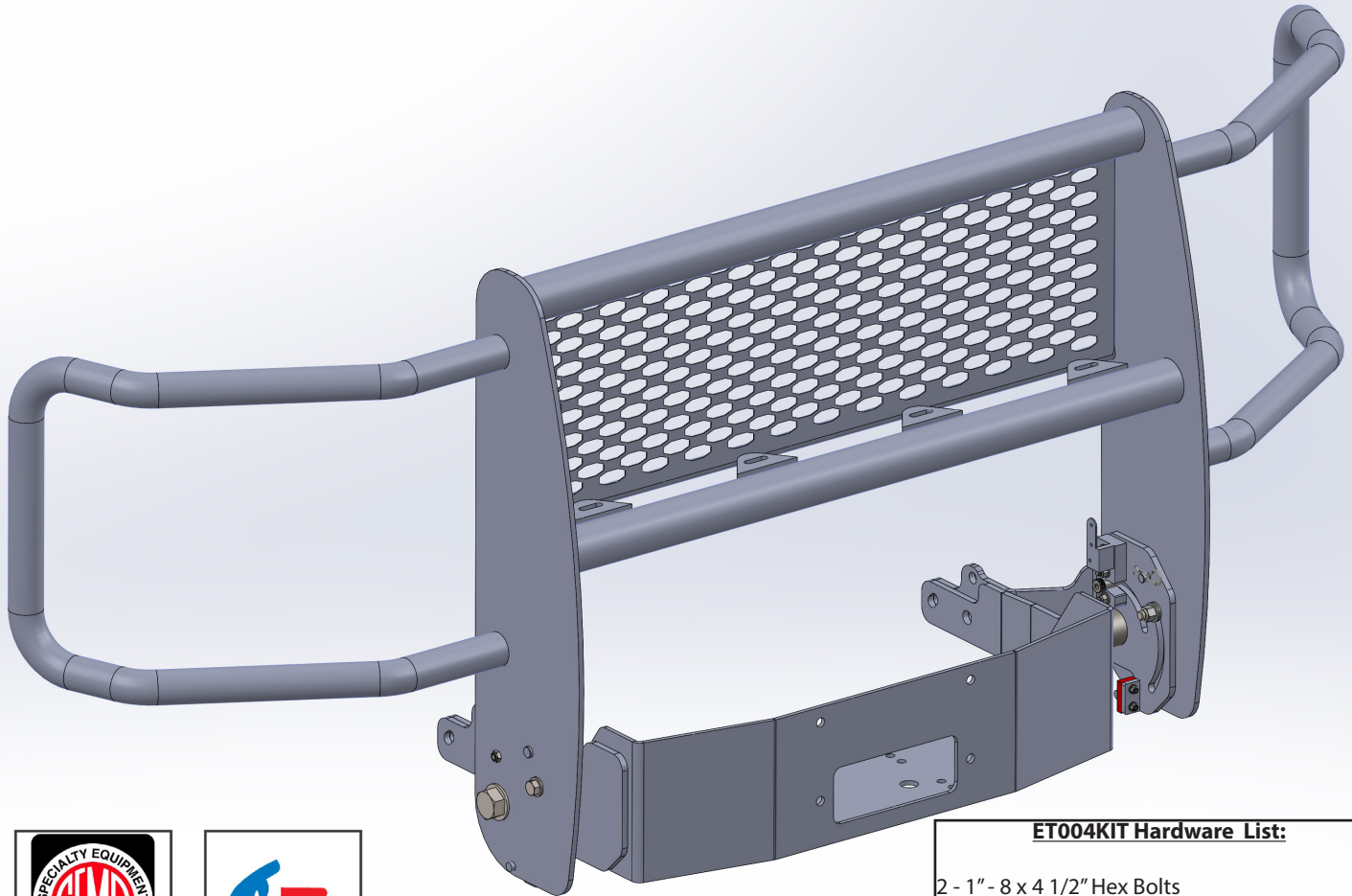

Parts List:

- 1 - Grill Guard ET004BL
- 1 - Winch Carrier ET004WC
- 2 - Long Nylon Sleeves
- 2 - Short Nylon Sleeves
- 2 - Urethane Bump Pads
- 1 - Pair of Rotary Latches
- 1 - ET004KIT Hardware Kit

ET004KIT Hardware List:

- 2 - 1" - 8 x 4 1/2" Hex Bolts
- 4 - 1" Flat Washers
- 2 - 1" - 8 Nylon Locking Nuts
- 4 - 5/8" - 11 Hex Bolts
- 8 - 5/8" Flat Washers
- 4 - 5/8"-11 Nylon Locking Nuts
- 2 - 1/2" - 13 x 2" Hex Bolts
- 4 - 1/2" Flat Washers
- 4 - 1/2" Nylon Washers
- 2 - 1/2" - 13 Nylon Locking Nuts
- 2 - 3/8" Striker Bolts
- 2 - 3/8" - 16 Thin Nylon Locking Nuts
- 6 - 5/16" - 18 x 1 3/4" Flat Head Phillips Bolts
- 6 - 5/16" Flat Washers
- 6 - 5/16: - Nylon Locking Nuts
- 4 - 10-32 x 3/4" Pan Head Phillips Screws
- 4 - #10 Flat Washers
- 4 - 10-32 Nylon Locking Nuts
- 2 - Clevis Pins
- 2 - Keeper Pins

*May include extra hardware.

Note: Completely read instructions before beginning installation!



420 N. Grove, Richardson, TX 75081
Tele: (800) 527 - 4345 Fax: (800) 442 - 5263
Web site: www.goindustries.com
E-mail: gosupport@goindustries.com

Winch System Grille Guard

Installation Instructions

ET004

2019 - 2020 Chevrolet Silverado
4500HD 5500HD 6500HD

Note: Completely read instructions before beginning installation!

1. Remove the contents from the box and check for missing or damaged parts. If parts are missing or damaged, contact the original place of purchase.
2. Using the 10-32 hardware, install the Bump Pads onto the main brackets as shown in **Diagram 1**.
3. Referring again to **Diagram 1**, install the Rotary Latches using the 5/16" hardware as shown. When tightening the 5/16" hardware, it is important to only secure the latches enough to firmly secure them to the main brackets.
If overtightened, the latches may be damaged and not work properly.
4. Loosen the six bolts that secure the bumper brackets as well as the tow hooks (if equipped) to the vehicle frame. The bumper will need to be supported so that it stays in the same general location, or you may support one side at a time, to install the mounting brackets in the following steps.
5. Remove the factory hardware, and install the winch carrier (ET004WC) between the frame rails. You may relocate the tow hooks (if equipped) as shown in **Diagram 2** using the 5/8" hardware provided. Once installed you may re-install the factory hardware and tighten until barely loose to allow for adjustment.

Note: Refer to Diagram 3 for the remaining installation steps

6. Once the brackets are installed, place the long and short nylon sleeves into the mounting bracket hub. Next, with the grille guard face down and in a flat position, Align the corresponding 1" holes in the grille guard with the mounting bracket hubs. Insert the 1" bolts with washer from the outside of the grille guard through the mounting bracket hub and place the remaining 1" flat washer along with the 1" nylon locking nut onto the bolt. This should help support the grille guard for all other hardware installation.
The 1" hardware should only be tightened until snug to allow for movement of the grille guard once installation is complete.
7. The next piece of hardware for installation is the 1/2" x 2" bolt with a washer from the outside of the grille guard. You will first need to slide one of the 1/2" nylon washers in between the inside of the grille guard upright and the mounting bracket. Insert the bolt with flat washer through the upright, through the nylon washer, and through the mounting bracket followed by another nylon washer, flat washer, and a 1/2" nylon locking nut.
This hardware should also only be tightened until snug to allow for movement of the grille guard once installation is complete.
8. The last piece to be installed will be the striker pin for the latch mechanism. Simply insert the striker bolt through the slot in the mounting bracket and into the 3/8" hole in the upright. Secure the pin using the slim 3/8" nylon locking nut. You may tighten this hardware to approximately 30 ft. lbs.
9. Raise the grille guard up so that it latches, and install the Clevis pins and keepers to secure the guard in the upright position.
10. Now you will want to adjust and level the grille guard and factory bumper before tightening the factory hardware to final torque to complete the installation. The recommended torque value for these bolts as well as the 5/8" hardware for the tow hooks is between 150 and 170 ft. lbs.

Note: Re-check all hardware for proper tightness upon completion and periodically inspect hardware and parts for signs of wear throughout the life of the product.

420 N. Grove, Richardson, TX 75081
 Tele: (800) 527 - 4345 Fax: (800) 442 - 5263
 Web site: www.goindustries.com
 E-mail: gosupport@goindustries.com

2019 - 2020 Chevrolet Silverado
 4500HD 5500HD 6500HD

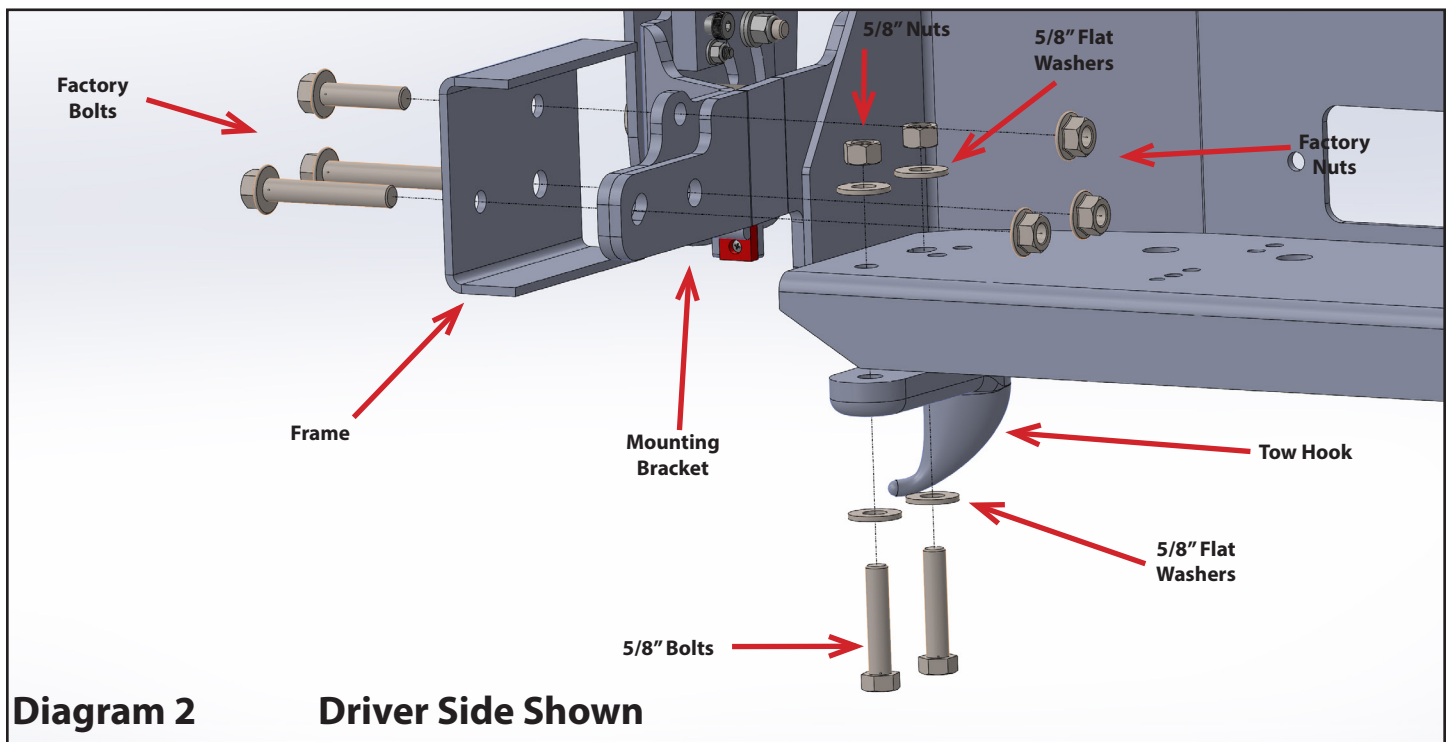
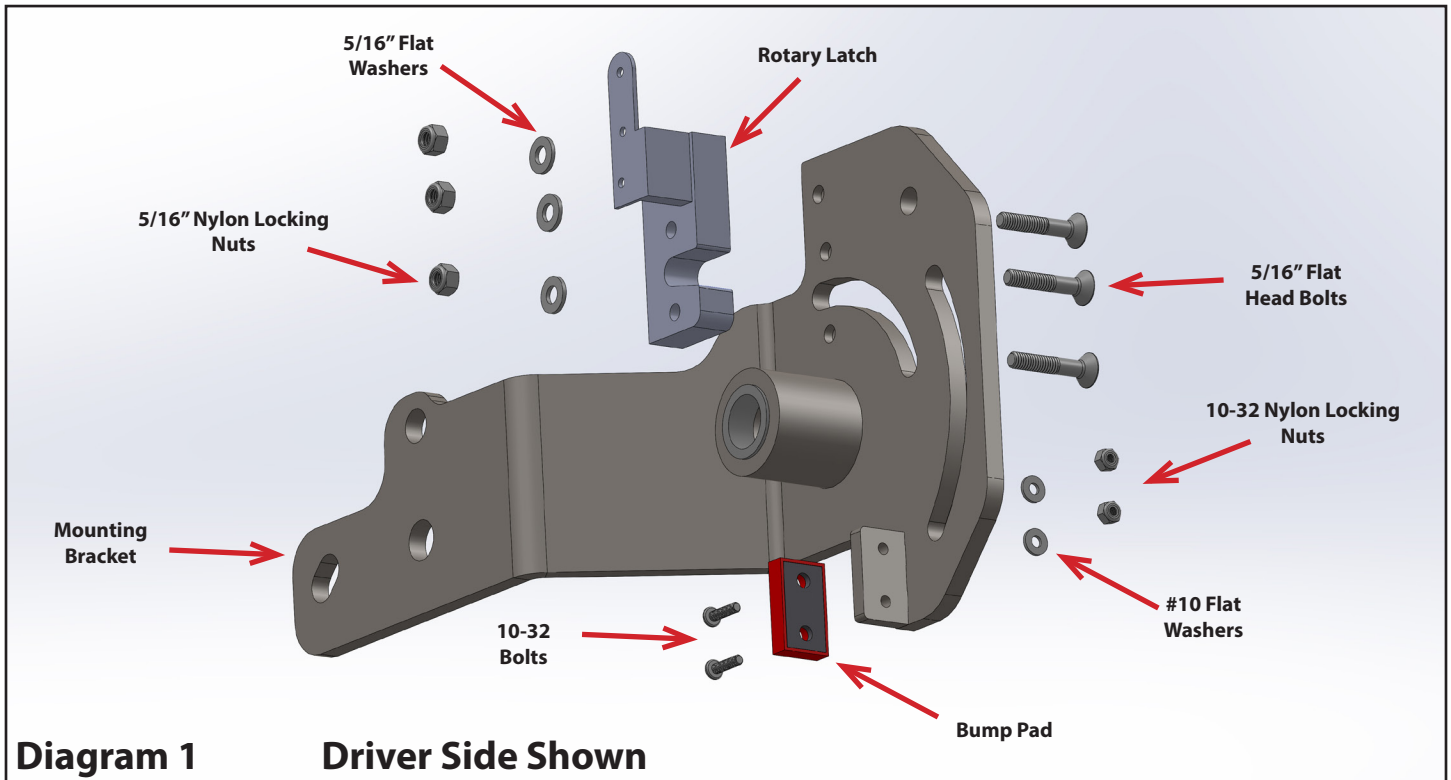

420 N. Grove, Richardson, TX 75081
 Tele: (800) 527 - 4345 Fax: (800) 442 - 5263
 Web site: www.goindustries.com
 E-mail: gosupport@goindustries.com

2019 - 2020 Chevrolet Silverado
 4500HD 5500HD 6500HD

