



1-800-779-2102

Mon – Thurs: 8:00am - 5:00pm | Friday: 8:00am - 4:00pm CST

**INSPECT YOUR PRODUCT FOR DAMAGE & MISSING
PARTS BEFORE PROCEEDING TO INSTALLATION**

PROCEDURE FOR RETURNS OR MISSING HARDWARE

-PLEASE CONTACT THE ORIGINAL POINT OF PURCHASE FOR:
SHIPPING DAMAGE, RETURNS, OR WARRANTY CLAIMS

-CONTACT DEE ZEE DIRECTLY FOR MISSING PARTS OR HARDWARE

WWW.DEEZEE.COM

REGISTER YOUR PRODUCT ONLINE: www.deezee.com/registration

VIEW INSTRUCTIONS ONLINE: www.deezee.com/instructions

⚠ WARNING: Cancer and Reproductive Harm
www.P65Warnings.ca.gov

Operating, servicing, and maintaining a passenger vehicle can expose you to chemicals such as lead, phthalates, engine exhaust, and carbon monoxide that are known to the State of California cause cancer and birth defects or other reproductive harm. To minimize exposure, service your vehicle and its accessories in a well-vented area and wear gloves or wash your hands frequently.



DEE ZEE, INC. WARRANTY AGREEMENT

Dee Zee, Inc. guarantees the original purchaser a limited lifetime warranty against manufacturer defects in materials, workmanship, and design under normal use, excluding damage resulting from road hazards such as gravel or other debris, product misuse, improper installation, impairments from accidents, product modifications, improper repairs, spills, vandalism, product neglect, or acts of God.

This warranty applies only to the original purchaser of new product(s) and is limited to the replacement of genuine Dee Zee products. Modification of any kind to Dee Zee products voids all warranty coverage. Warranty does not include electrical components, installation, cost of removal, labor, transportation costs, loss of use, inconvenience, or consequential damages.

WARRANTY COVERAGE - MATERIALS & WORKMANSHIP

LIMITED LIFETIME WARRANTY:

- STAINLESS STEEL: Side Steps, Grill Guards, Bull Bars, Bed Caps, and Side Rails
- ALUMINUM: Side Steps, Running Boards, Storage Boxes, Transfer Tanks, Bed Protection, Side Rails, Invis-A-Racks, and Cab Racks
- PLASTIC: Storage Boxes
- OTHER: Front and Rear Bumpers

THREE-YEAR WARRANTY:

- POWDER-COATED / E-COATED STEEL: Side Steps, Running Boards, Storage Boxes, Transfer Tanks, Cab Racks, Sport Bar Ladder Racks, Cargo Carriers, Mounting Brackets (NX, Rough Step, and Bumper Guards only)
- OTHER: Tailgate Assist, Bed Mats, Floor Mats, Auxiliary Fuel Connection Kits, and All Products Not Otherwise Listed Individually

WARRANTY COVERAGE – FINISH PROTECTION

The finish of all Dee Zee products is covered for one-year (1) from the date of purchase. Dee Zee products have a high quality finish that must be cared for and maintained like any other exposed finish on the vehicle. Protect the finish with non-abrasive automotive wax (e.g. Pure Carnuba) on a regular basis. Applying soaps, polishes, or waxes that contain an abrasive compound may scratch the finish and leave the exposed material susceptible to corrosion.

WARRANTY COVERAGE – COMPONENT PARTS

Operational items such as shocks, latches, hinges, and wear items including, but not limited to, mud flaps, step pads, toolbox tray, end caps, hardware, seals, etc. have a one-year (1) warranty. Replacement component parts can be ordered via credit card (MasterCard or VISA) by calling 1-800-779-2102. All replacement parts are non-returnable and non-refundable.

GPI® FUEL PUMPS & ACCESSORIES

All Great Plains Industries (GPI) products, including transfer tank pumps and fuel meters are covered by GPI's warranty policies. Dee Zee's warranty terms do not apply to GPI products. To submit a warranty claim, please contact GPI at 1-800-835-0113 or visit www.gpi.net.

WARRANTY SUBMISSION PROCEDURE

All warranty claims will be initiated at the place of purchase. The original purchaser will be required to present the original sales receipt with purchase date shown and provide photographs of the defect.

In the event the originally purchased product style is no longer available, Dee Zee will warranty the defective part with a current equivalent. If a comparable product is no longer available, the product would be returned to the store of purchase for a refund or the applicable cost difference can be paid to choose an alternate style.

DISCLAIMER

All products are sold as appearance accessories and should not be relied upon as protection for the vehicle or its occupants in the event of an accident. Vehicles equipped with a supplemental restraints system (air bags) deployed by impact and collision avoidance systems should not be modified in any way. Always consult the vehicle manufacturer if you have any questions regarding supplemental restraint systems and sensors.

Buyer must accommodate front and rear sensors during product installation and assumes all risk should these be tampered, rerouted, severed, or disconnected. This includes disabling visual, audio, or vibration alerts into the cab. Buyer assumes all risk and responsibility for wiring any supplemental auxiliary lights.

Buyer assumes all risk, liability, and cost for the installation and use of Dee Zee products. Dee Zee, Inc. assumes no liability for injury, loss, incidental or consequential damages in the event of an accident.



Thank you for choosing Dee Zee to add function and accessorize your vehicle. Dee Zee has been a staple brand in the truck accessory market since 1977 and we hold a reputation of quality manufacturing based in America's Heartland. Our products are born through careful engineering and backed by industry leading warranty programs. We appreciate the opportunity to serve you and your vehicle!

Review the instruction pages in their entirety to prepare the required tools

Warning: Please check for wiring or other obstructions before drilling any holes in the vehicle. If it is necessary to drill any holes, Dee Zee recommends putting a sealant or rust inhibitory around all holes drilled into the body of the vehicle.

It is the sole responsibility of the vehicle owner to check for tire clearance. It is unlawful and dangerous to ride on any external vehicle step while the vehicle is in motion.

Cleaning: To be entitled to all warranty rights offered with the product, Dee Zee steps need to be cleaned regularly with a mild detergent. Do NOT use abrasive cleaners. For stainless steel products, the application of a high grade automotive wax is recommended.









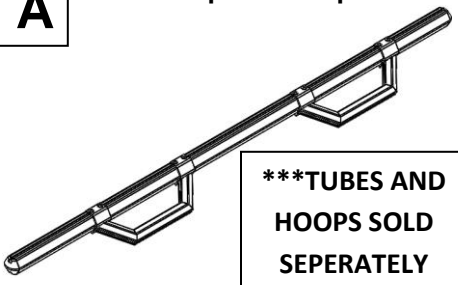
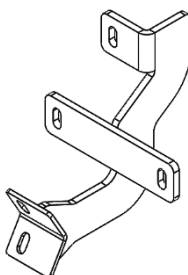
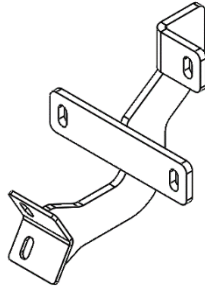
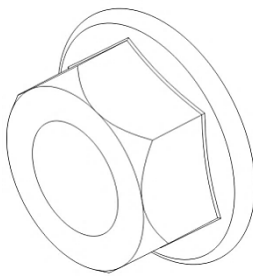
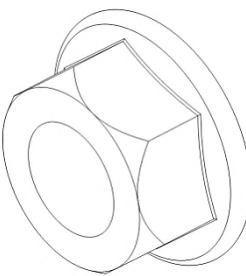

Dee Zee Cares - Please Recycle

For an electronic version of these instructions visit: www.deezee.com/instructions

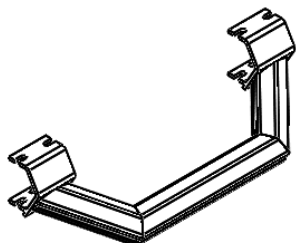
Register your product online: www.deezee.com/registration

Hex Hoop Side Step Installation Instructions

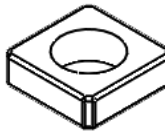
DZ 66327 (2015-Current) FORD F150 Pickup, (2017-Current) SuperDuty

<p>A Hex Hoop Side Step</p>  <div style="border: 1px solid black; padding: 5px; width: fit-content; margin: 10px auto;"> <p>***TUBES AND HOOPS SOLD SEPERATELY</p> </div> <p>Various X2</p>	<p>B Front Bracket</p>  <p>B 2510RP X2</p>	<p>C Middle and Rear Bracket</p>  <p>B 2510LP X4</p>
<p>D M8 Hex Paint Clearing Nut</p>  <p>PN 1140 X18</p>	<p>E 8mm Hex Flange Nut</p>  <p>PN 526 X12</p>	<p>F Main Tube</p>  <p>FROM HEX HOOP SIDE STEP X2</p>
<p>G Side Step</p>  <p>FROM HEX HOOP SIDE STEP Reg Cab X2 Ext/Crew Cab X4</p>	<p>H 8mm X 20mm Square Head Bolt</p>  <p>FROM HEX HOOP SIDE STEP Reg Cab X8 Ext/Crew Cab X12</p>	<p>I 8mmX 16mm Button Head Bolt</p>  <p>FROM HEX HOOP SIDE STEP Reg Cab X16 Ext/Crew Cab X32</p>
<p>J 1/4" Flat Washer</p>  <p>FROM HEX HOOP SIDE STEP Reg Cab X16 Ext/Crew Cab X32</p>	<p>K 8mm X 1.25 Square Nut</p>  <p>FROM HEX HOOP SIDE STEP Reg Cab X16 Ext/Crew Cab X32</p>	<p>L Endcap</p>  <p>FROM HEX HOOP SIDE STEP X4</p>

Tools Required

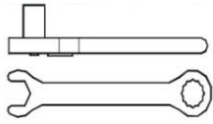

Ratchet / Wrench
13mm

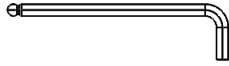

Allen Wrench
5mm

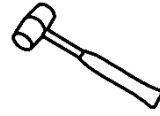

Rubber Mallet

Tools Recommended



Tape Measure

NOTE: FOR REGULAR CAB AND SUPERCAB, THE MIDDLE BRACKET LOCATION IS NOT AVAILABLE. PROCEED AS DIRECTED USING FRONT AND REAR MOUNTING LOCATIONS. The Middle Brackets (C) and extra hardware may be discarded.

1

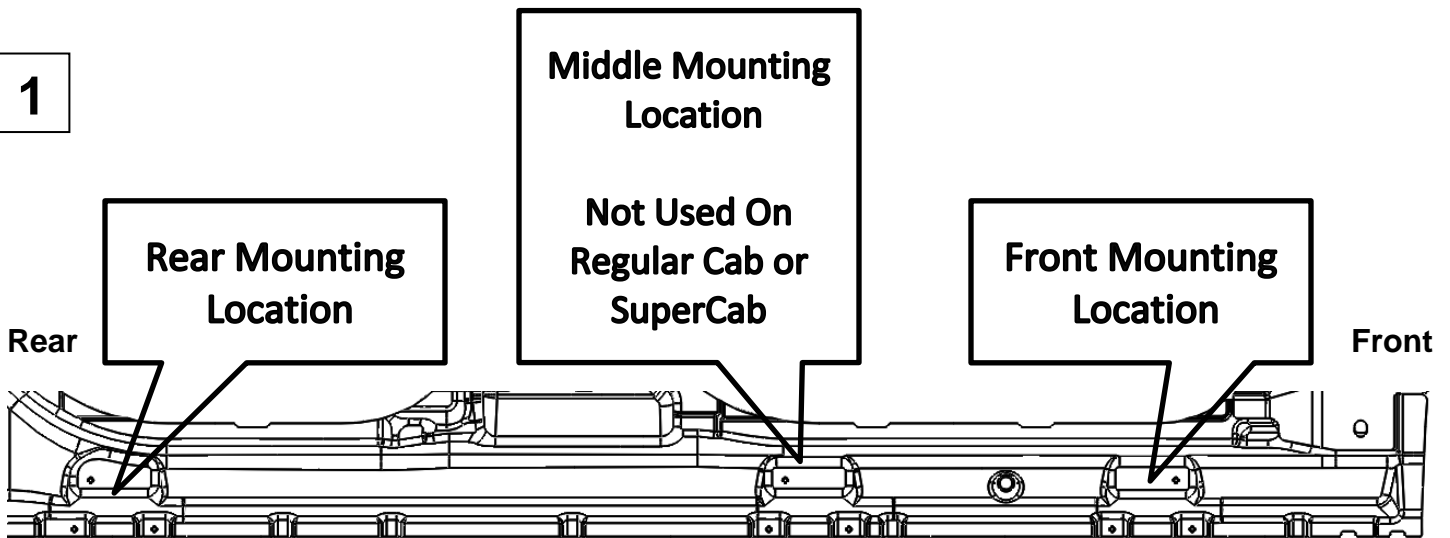

Driver's Side SuperCrew Shown Above

2

Attach the Front Bracket (B) to the Front Mounting Location on both sides with two M8 Nuts (D) by using a 13mm ratchet or wrench. **Do not completely tighten the nuts at this time.**

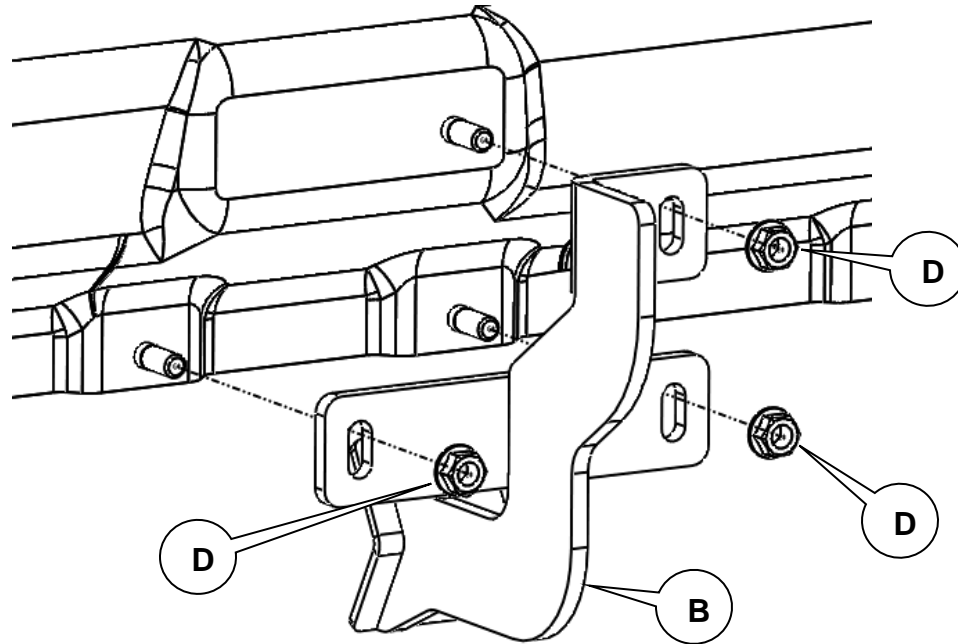

3

Attach the Middle and Rear Bracket (C) to the Middle Mounting Location and the Rear Mounting Location on the Driver's Side with two M8 Nuts (D) by using a 13mm ratchet or wrench. **Do not completely tighten the nuts at this time.** If you have a Regular Cab, There is no Middle Location.

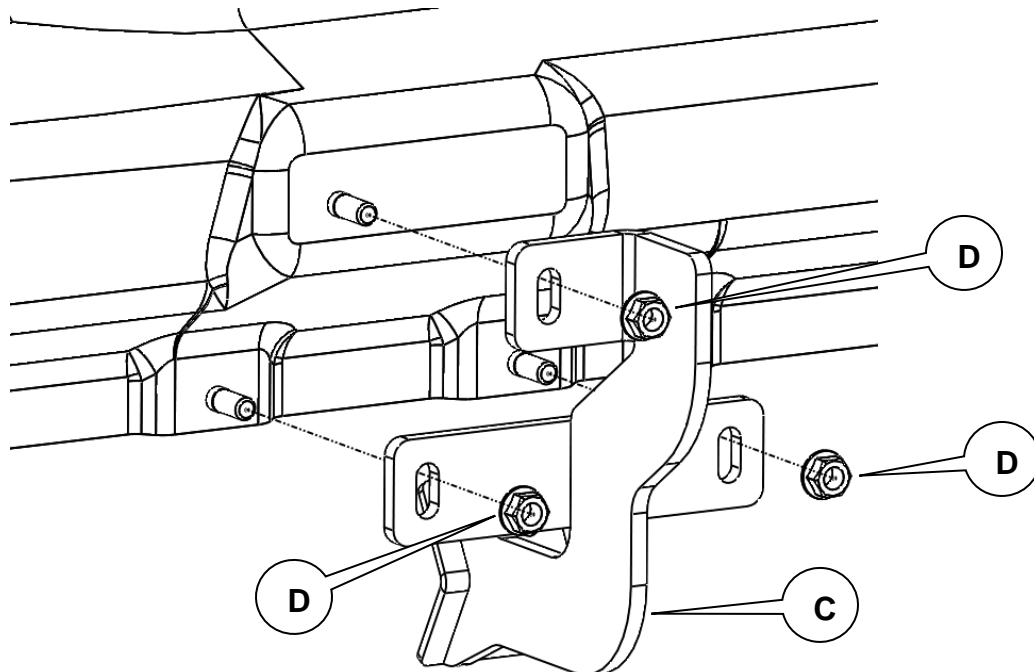

- 4** Install the 8mm square head bolts (H) evenly into the rear two channels of the main tube (F). For two braces on vehicle install four bolts, for three braces on vehicle install six bolts.

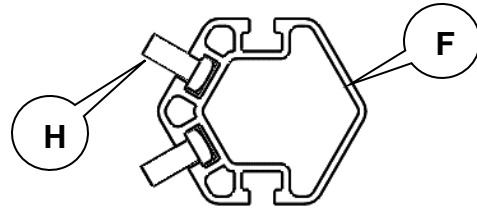
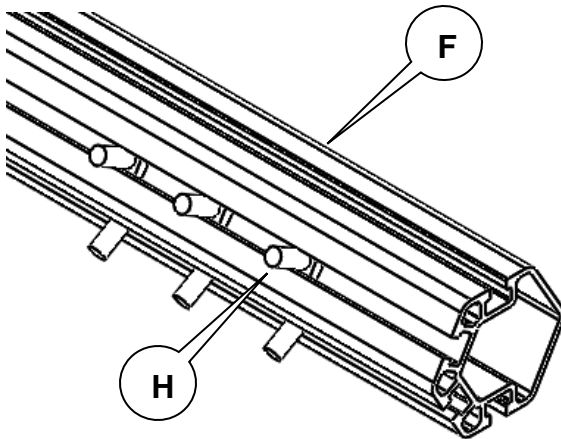

If using 2 brackets from steps 2 and 3, install 4 bolts (H).

If using 3 brackets from steps 2 and 3, install 6 bolts (H).

- 5** Install endcaps (L) on both ends of the main tube (F) by first hand pushing them to set in place, then hitting them with a rubber mallet. Make sure that the spring clip is positioned the correct way (see image below). **Complete this step before installing the tube on the vehicle.**

Towards channels with bolts from step 4

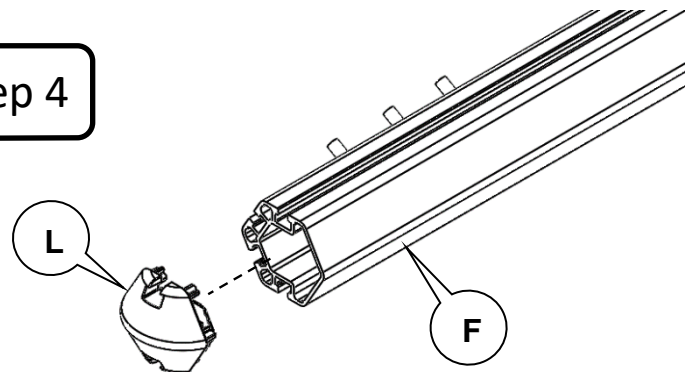
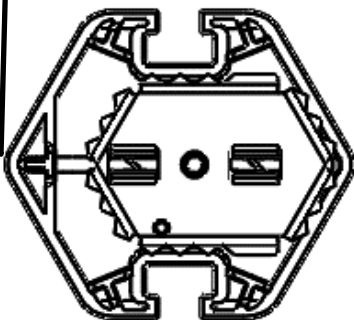

Before completing this step ensure that the correct amount of bolts are in the channels. Installing the endcaps will lock the bolts in the channels.

6

Mount the tube to the brackets by sliding the bolts into the slots of the brackets and install an M8 nut (E). Depending on the tube color, there may be hook marks from the paint process. Install the tube with the hook mark side down. Center the main tube using tape measure. **Fully tighten the tube to the brackets. Then tighten the brackets to the vehicle.**

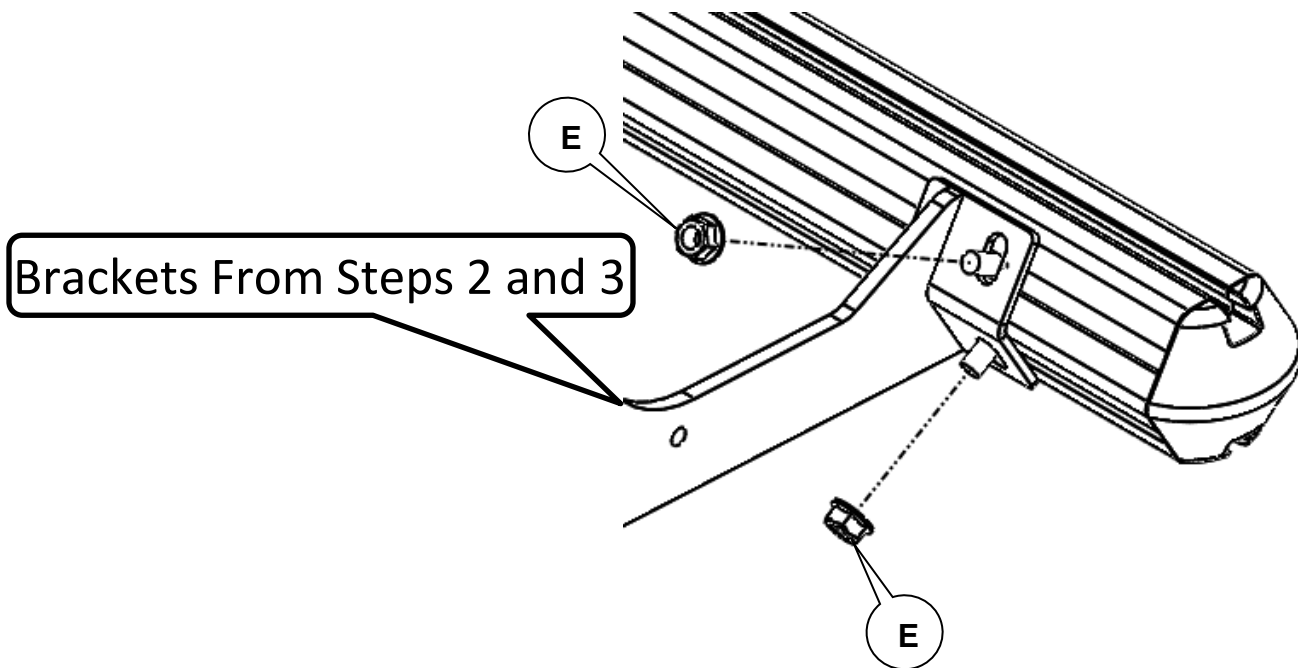

7

Assemble bolts (I), washers (J), and nuts (K). Only turn the bolts two times into the nuts. There will be eight bolts per Side Step. Four bolts in the top, and four in the bottom channel per Side Step. Then slide the nut into the upper and lower channels roughly where the Side Step(s) (G) will be located.

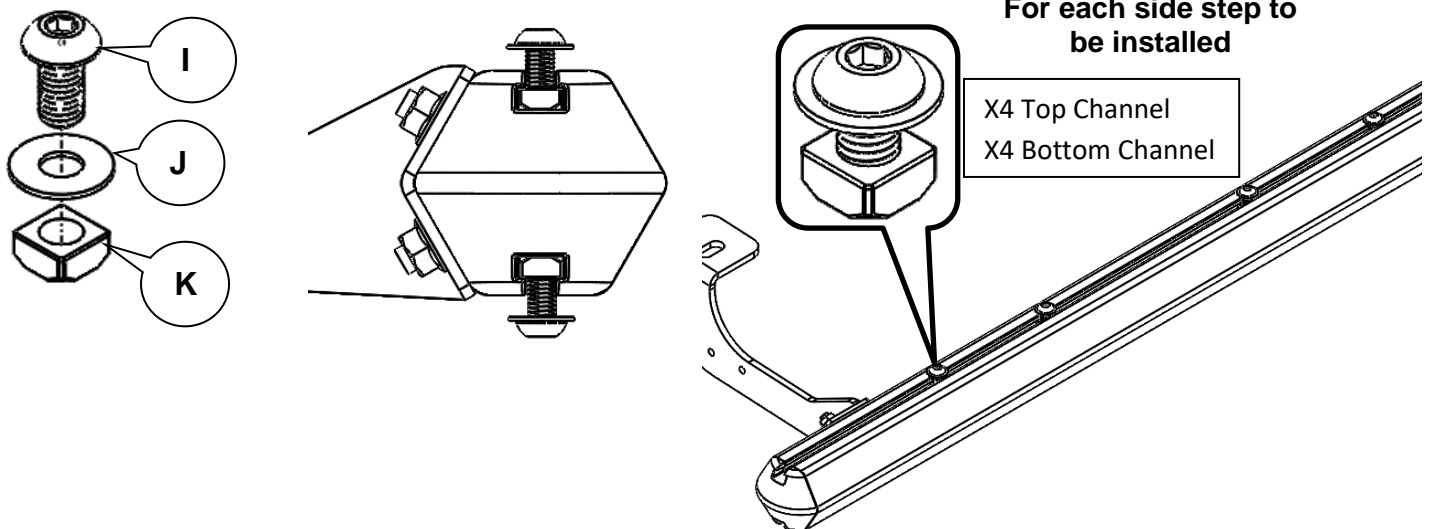

- 8** Install Side Step (G) by placing the side step(s) on the main tube (F) and sliding the button head bolts into the slots of the side step with the washer on top of the Side Step. Double check the placement of the side step by opening the door(s) then adjust as necessary. **Fully tighten all hardware at this time.**

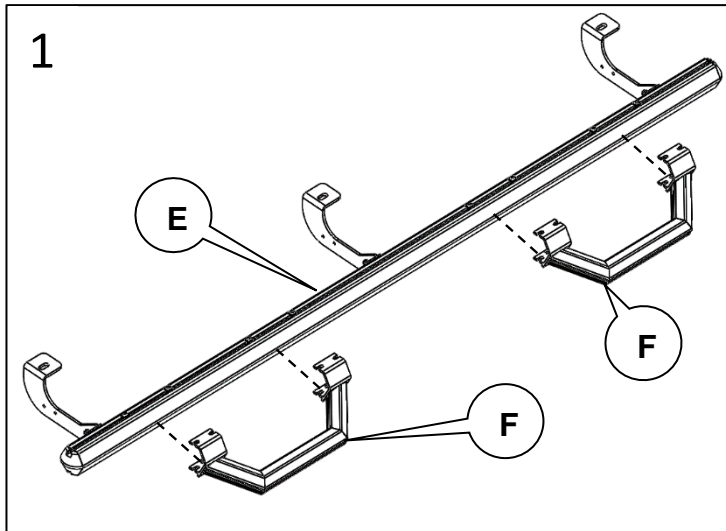

Use tape measure to ensure tubes and step locations match on both sides

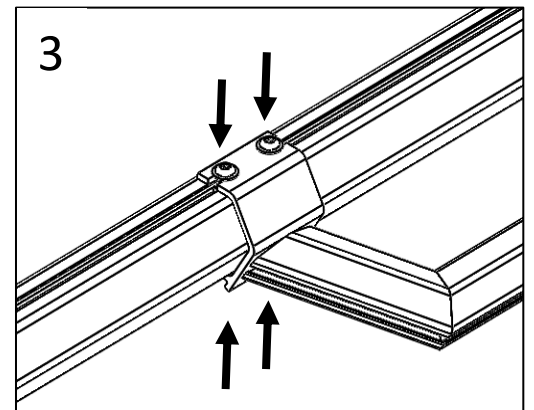
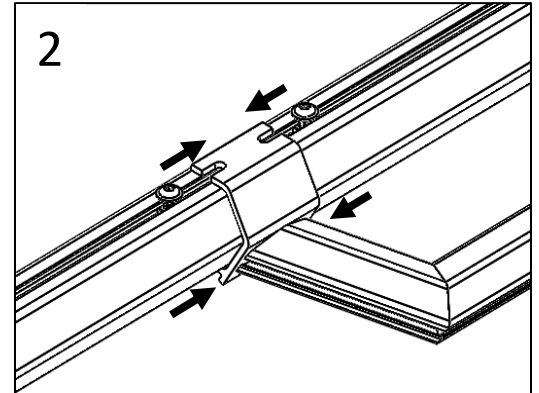

Repeat Steps 1-8 on Passenger side.