



# INSTALLATION INSTRUCTIONS

152501 KITS

6-7" LIFT KIT

300 W. Pontiac Way Clovis, CA 93612 toll free: 1-800-445-3767 web: www.belltech.com

## 2015-2020 Ford F150 4WD

### 6-7" Lift Kit

Thank you for being selective enough to choose our high quality BELLTECH PRODUCT. We have spent many hours developing our line of products so that you will receive maximum performance with minimum difficulty during installation

Note: Confirm that all of the hardware listed in the parts list is in the kit. **Do not** begin installation if any part is missing. Read the instructions thoroughly before beginning this installation.

**Warning: DO NOT** work under a vehicle supported by only a jack. Place support stands securely under the vehicle in the manufacturer's specified locations unless otherwise instructed.

**Warning: DO NOT** drive vehicle until all work has been completed and checked. Torque all hardware to specified values.

Reminder: Proper use of safety equipment and eye/face/hand protection is absolutely necessary when using these tools to perform procedures!

Note: It is very helpful to have an assistant available during installation.

Note: Please refer to component and hardware list before beginning installation to insure all necessary pieces have been supplied and packaged.

#### Exceptional Customer Experience Guarantee:

**STOP!** We strive for an exceptional experience for all of our valued customers. If, for any reason, you need assistance with your Belltech products, please do not return the products to the store or website you purchased from. Please call our dedicated experts at (1-800-445-3767) from 6am to 5pm PST.

#### RECOMMENDED TOOLS:

- Properly rated floor jack and support stands
- Wheel chocks
- Torque wrench up to 200 ft/lbs range
- Metric socket wrench set
- Metric wrench set
- Metric hex key set
- Tape measure
- Dead blow hammer
- Marking pen
- Safety Glasses
- Reciprocating Saw and/or Angle Grinder with metal cutting blades



DIFFICULTY:



INSTALLATION TIME: 6-8hrs + Alignment

## 1) KIT PREPERATION

- a) Before beginning the install process, measure the hub to fender heights for your vehicle so you can compare the resulting height to the original. Measure vertically from the center of the wheel to the inner edge of the fender. Record the results here:

LF: \_\_\_\_\_ RF: \_\_\_\_\_ LR: \_\_\_\_\_ RR: \_\_\_\_\_

- b) Park the vehicle on a smooth, level concrete or seasoned asphalt surface and activate the parking brake. Block the rear wheels of the vehicle with appropriate wheel chocks; making sure the vehicle's transmission is in 1st gear ( manual) or " Park" (automatic).

! It is very important that the vehicle is properly supported during this installation to prevent personal injury and chassis damage. Make sure that the support stands are properly placed prior to performing the following procedures. We **DO NOT RECOMMEND** using wheel ramps while performing this installation. !

## 2) FRONT REMOVAL INSTRUCTIONS

- a) Jack up the front of the vehicle. Place jack stands under the frame rails and lower onto jack stands letting the front suspension hang.
- b) Remove the factory splash guards under the engine and transmission. **(PHOTO 1)**
- c) Undo the lug nuts (21mm if OEM) and remove the wheels.
- d) Remove the sway bar with end links from the vehicle. **(PHOTO 2)**
- e) Remove the tie-rod nut. Strike the side of the mount with a dead blow hammer or use a puller tool to dislodge the tie rod end. **(PHOTO 3)**
- f) Remove all mounting points for the brake line and abs sensor wire from the control arm and spindle. **(PHOTO 4)**

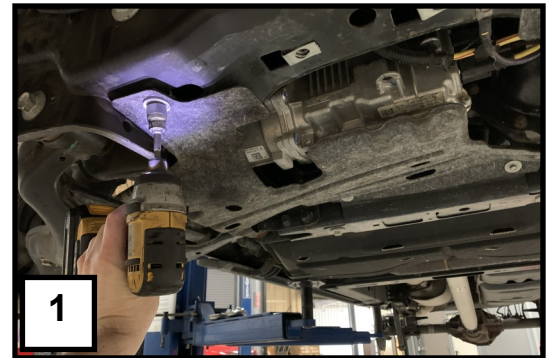
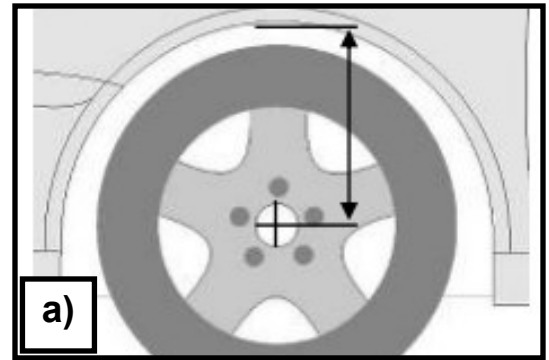

- a) Undo the Brake Caliper mounting bolts. Hang the calipers to prevent stretching of the lines using large zip ties or hangers. Remove the rotors. **(PHOTO 5)**
- b) Remove the brake backing plate and the ABS sensor from the Spindle. **(PHOTO 6)**
- h) Remove the cap in the center of the hub assembly with a pair of wide jaw pliers to expose the axle nut. Remove the nut using a 13mm socket. **(PHOTO 7)**
- i) Remove the Vacuum actuator line from the behind the Spindle/hub assembly by carefully pulling it. **(PHOTO 8)**
- j) Loosen but do not remove the nuts from the upper and lower ball joints. Use a hammer or puller tool to dislodge the spindle from the ball joints.
- k) Remove the spindle from the vehicle.

**! Always be careful not to damage the vacuum actuator or grease seals with the axle shaft while removing or installing spindles.! (PHOTO 9)**

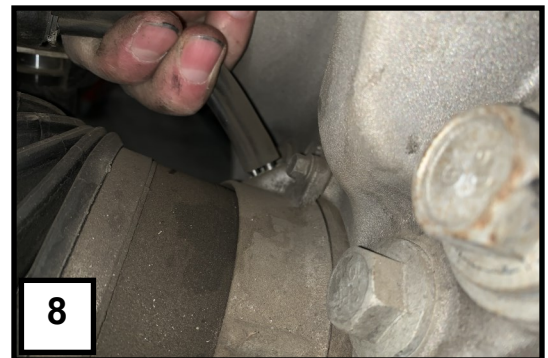

- h) Using a 18mm socket, remove the lower strut mounts from the control arms (**PHOTO 10**)
- i) Using a 21mm and 27mm wrench, remove both lower control arms. (**PHOTO 11**)
- j) Remove top mount nuts and remove both front struts from the vehicle. Set aside (**PHOTO 12**)
- k) Unplug the electrical wires for the power steering rack. Pull back red lock tabs, and squeeze release buttons to remove connectors (**PHOTO 13**)
- l) Use the drivers seatbelt, or a steering wheel holder tool to hold the steering wheel from rotating. Remove the pinch bolt from the steering input shaft and separate shaft from steering rack. (**PHOTO 14**)

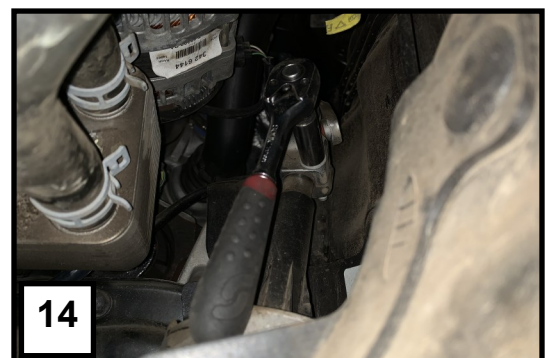
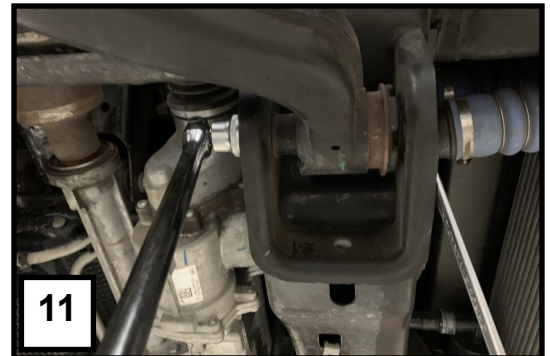

- m) Remove the 2 bolts holding the steering rack to the frame and carefully remove the power steering rack. Do not turn the input shaft, so it can be reinstalled in the same orientation. **(PHOTO 15)**
- n) Disconnect driveline and rubber vent hose from the front differential. Support the front driveline by hanging it to prevent damage. **(PHOTO 16, 17)**
- o) Remove center section of rear crossmember (near the rear of the front differential)
- p) Remove front differential from vehicle.
- q) Once the differential is out, reinstall the power steering rack in reverse order of removal. Once installed, you may remove the steering wheel holder.
- r) Using the template in the back of these instructions, mark a guide line on the DRIVERS SIDE of the rear crossmember mount. Cut on the marked line to create room for the re-located differential. Grind any rough edges and apply paint to prevent rust. **(PHOTO 18, 19, 20)**
- s) Remove factory hubs and vacuum actuators from front spindles. Take note of the orientation of the ABS port and vacuum nipples **(PHOTO 21)**

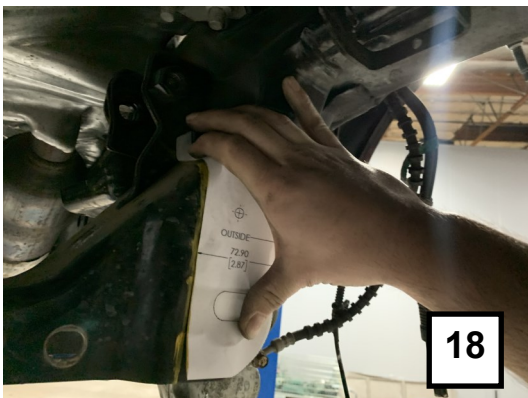
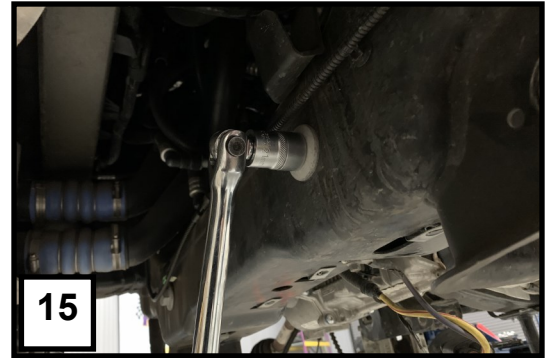

## 2) FRONT INSTALL INSTRUCTIONS

- a) Install front differential drop bracket to differential using supplied hardware. Do not fully tighten the bolts yet. Attach the new extended differential vent hose as shown. **(PHOTO 22)**
- b) Supporting the front differential with a floor jack, install it into the frame using OE hardware.
- c) Install the rear crossmember into the frame using supplied M18 hardware. Insert bolts from the rear, but do not install nuts yet. Align the rear differential mounting bushing into the crossmember and install with supplied hardware. **(PHOTO 23)**
- d) Support rear crossmember with a floor jack. One side at a time, remove crossmember mounting bolt, and reinstall with the sway bar drop bracket attached. **(PHOTO 24)**
- e) Attach top of sway bar drop bracket to the frame with OE hardware. Snug nuts up, but do not tighten fully.
- f) Torque all rear crossmember bolts to 180 ft lbs. Torque front differential/bracket bolts and sway bar drop bracket bolts to OE spec.
- g) Using the supplied front driveline spacer and extended hardware, reattach the front driveline to the differential. Torque to OE spec. **(PHOTO 25)**
- h) Attach the new extended differential vent hose extension to the factory plastic hose.
- i) Install front crossmember with supplied hardware. Torque bolts to 180 ft lbs **(PHOTO 26)**

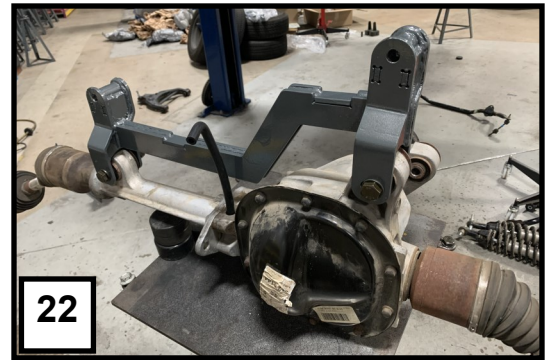

- j) Loosely install lower control arms into the new cross-members with OE hardware. **(PHOTO 27)**

---

**For Strut Spacer Installation:**

Please refer to the included instructions for strut spacer 152501-120. All required hardware is provided.

**For Trail Performance Strut Installation:**

Please refer to the instructions for setting ride height included within the strut 28007.

---

- k) Reinstall factory hubs and vacuum actuators into the new lift spindles. Make sure to keep proper alignment of the ABS sensor port and vacuum hose fittings. Tighten hardware to OE specs. **(PHOTO 28)**
- l) Install new lift spindles onto vehicle. Make sure the front axle is fully seated into the hub. Tighten upper and lower ball joints, as well as the axle nuts. Torque all to OE spec and reinstall dust caps over spindle nuts. **(PHOTO 29)**
- m) Unbolt front brake line brackets from frame. Unclip the lines from any attachments to the frame near the control arm mount to allow everything to be moved downward. **(PHOTO 30 & 31)**

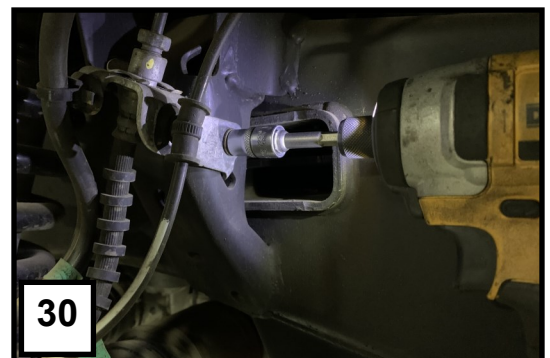
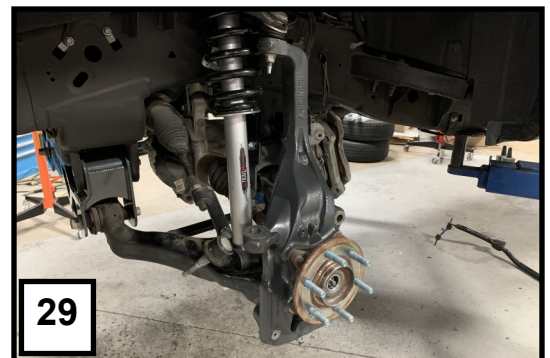
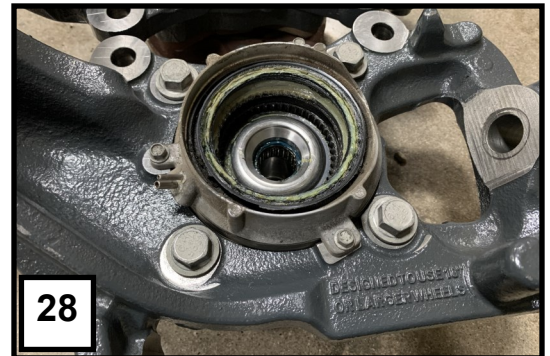

- n) Install new brake line drop brackets to the frame with OE hardware. **(photo 32)**
- o) Install OE brake line to new bracket with supplied hardware. Remove any retaining clips necessary to allow hard lines to flex downward toward the new bracket.
- p) Attach vacuum actuator hoses and ABS sensor to spindle.
- q) Install brake rotor and caliper onto spindle. **(PHOTO 33 &34)**
- r) Attach outer tie rod to spindle. Torque to OE spec. **(PHOTO 35)**
- s) Double check all ABS and brake lines to confirm they will not interfere with other moving parts or be pulled on while steering.
- t) Install sway bar onto new drop brackets using supplied hardware. Attach end links to control arms using OE nuts. **(PHOTO 36)**

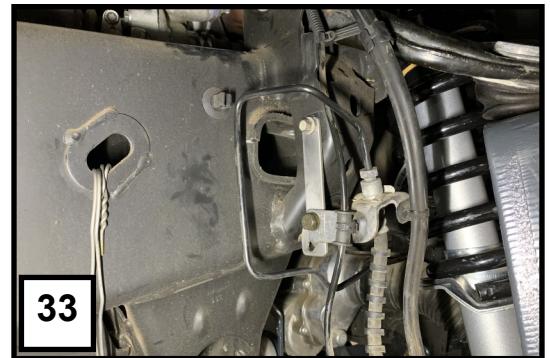

- u) Remove nuts from the center crossmember near the transmission. **DO NOT REMOVE THE BOLTS.** **(PHOTO 37)** \*\*Some models may have a wire harness on the passenger side. Temporarily remove the bolts holding the harness to the crossmember to access the crossmember bolts.\*\* **(PHOTO 38)**
- v) Install compression arm rear mounting brackets using OE nuts and bolts. Reattach wire harness if removed. **(PHOTO 39)**
- w) Press the supplied compression arm bushings and sleeves into the compression arms. Using supplied hardware, install the compression arms into the tabs on the rear crossmember, and the previously installed brackets. **(PHOTO 40)**
- x) Mount Skid plate across both crossmembers using supplied hardware. **(PHOTO 41)**
- y) Install wheels. Lower vehicle back onto the ground. Torque the wheels and lower control arm bolts.
- z) Check torque of all fasteners and check for interference of all brake lines and moving parts.

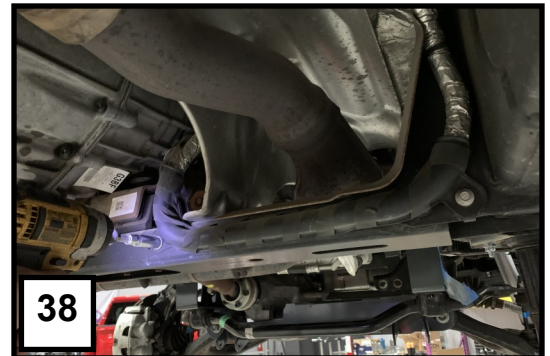

### 3) REAR REMOVAL INSTRUCTIONS

- a) Jack up the rear of the vehicle. Place jack stands under the frame rails and lower onto jack stands letting the rear suspension hang.
- b) Supporting the differential with a floor jack, Remove Rear shocks. Hardware will be reused. **(PHOTO 1)**
- c) Disconnect brake line bracket from the inside of the driver frame rail above the axle. **(PHOTO 2)**
- d) Using a pry tool. Release the rear 2 brake line retention clips from the frame rail. This will allow the brake line bracket to be lowered without kinking the hard lines. **(PHOTO 3)**
- e) Using a 13mm socket on an extension, remove factory bump stop cup from the frame. **(PHOTO 4)**
- f) Keeping the axle fully supported, lower it until the leaf springs are decompressed.
- g) Remove all 8 U bolt nuts and U bolts. The lower U bolt plates will be reused. **(PHOTO 5)**
- h) Lower the axle to make room to install the new lift blocks. Remove OE blocks if equipped.

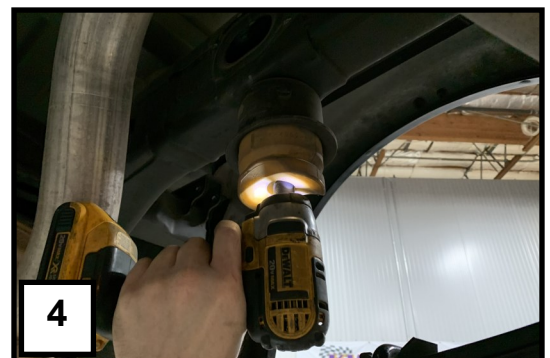

#### 4) REAR INSTALL INSTRUCTIONS

- i) Install rear lift blocks with the taller end in the back to aim the pinion up toward the transmission. **(PHOTO 6)**
- j) Making sure all pins and holes are aligned and seated. Raise the axle against the leaf springs to close all gaps.
- k) Install the new U-bolts using the provided hardware and OE lower U bolt plates. Torque to 90 ft lbs.
- l) Install new rear BELLTECH TRAIL PERFORMANCE shocks (TP2722EE) using the OEM hardware. **(PHOTO 7)**
- m) Install Brake line drop bracket onto frame, reusing OE bolt. **(PHOTO 8)**
- n) Install brake lines to the drop bracket using the provided M8 hardware. **(PHOTO 9)**
- o) Remove the OEM bump stop cup/bump stop **(PHOTO 10)**
- p) Flatten or cut off locating tabs on bump stop cups. **(PHOTO 11)**
- q) Reinstall bump stops with provided composite spacer and extended hardware, making sure it is rotated in the correct orientation. **(PHOTO 12)**
- r) Reinstall wheels if removed, and lower truck to the ground.
- s) Double check torque of all components.



## 4) **Post Install**

- a) Check that all components and fasteners have been properly installed, tightened and torqued.
- b) Check brake hoses, and other components for any possible interference.
- c) Torque all lug nuts to OEM ( factory) specifications.
- d) Test drive the vehicle in a remote location so that you can become accustomed to the altered driving characteristics and handling. Be aware that the vehicle will handle substantially different now that it has been modified.
- e) We recommend the vehicle be taken to a qualified wheel alignment facility to be realigned to factory specifications after completing the install.
- f) Installation is complete. Check ALL of the hardware and re-torque at intervals for the first 10, 100, 1000 miles.

# COMPONENTS PARTS LIST

152501BK KIT		
P/N	ITEM DESCRIPTION	QTY
LK51000	COMPONENTS KIT	1
LK5001	COMPONENT KIT	1
LK2352	COMPONENT KIT	1
LK2003	STRUT SPACER KIT	1
LK9705R	LK SHOCK SET	1

LK51000		
P/N	ITEM DESCRIPTION	QTY
152501-101-99	FRONT CROSSMEMBER	1
152501-102-99	REAR CROSSMEMBER	1
152501-113L-99	SWAYBAR DROP DOWN BRKT DRIVER SIDE	1
152501-113R-99	SWAYBAR DROP DOWN BRKT PASSENGER SIDE	1
152501-107L-99	COMPRESSION ARM BRKT DRIVERSIDE	1
152501-107R-99	COMPRESSION ARM BRKT PASSENGER SIDE	1
152501-201-99	LIFT BLOCK	2

LK5001		
P/N	ITEM DESCRIPTION	QTY
152501-106-99	COMPRESSION ARM	2
152501-108-99	SKIT PLATE	1
152501-104-99	DIFFERENTIAL DROP DOWN BRKT	1
152501-202	U-BOLT (M14-2.0 x 12.5" x 3.75")	4
LK5001A	SUB-KIT -A	1

LK2352		
P/N	ITEM DESCRIPTION	QTY
152501-103L	SPINDLE DRIVER SIDE	1
152501-103R	SPINDLE PASSENGER SIDE	1

152501TP KIT		
P/N	ITEM DESCRIPTION	QTY
LK51000	COMPONENTS KIT	1
LK5001	COMPONENT KIT	1
LK2352	COMPONENT KIT	1
LK9705F	LK SHOCK SET	1
LK9705R	LK SHOCK SET	1

LK2003		
P/N	ITEM DESCRIPTION	QTY
152501-120	STRUT SPCER	2

LK9705F		
P/N	ITEM DESCRIPTION	QTY
28007	TRAIL PERFORMANCE STRUT	2

LK9705R		
P/N	ITEM DESCRIPTION	QTY
TP2722EE	TRAIL PERFORMANCE SHOCK	2

LK5001A		
P/N	ITEM DESCRIPTION	QTY
152501-141	VENT TUBE EXTENSION	1
152501-111-95	FRONT BRAKE LINE BRKT	2
152501-140-95	DRIVE-LINE SPACER	1
150210-203	REAR BUMP STOP EXTENSION	2
152501A-777	HARDWARE KIT CROSSMEMBERS	1
152501B-777	HARDWARE KIT DIFFERENTIAL DROP BRKT	1
152501C-777	HARDWARE KIT COMPRESSION ARMS	1
152501D-777	HARDWARE KIT U-BOLT/BUMP STOPS	1
152501F-777	HARDWARE KIT SKID PLATE	1
152501G-777	HARDWARE KIT BRAKE LINE BRKTS	1
152501J-777	HARDWARE KIT	1

# HARDWARE PARTS LIST

<b>152501A-777</b>		
<b>P/N</b>	<b>ITEM DESCRIPTION</b>	<b>QTY</b>
<b>112131</b>	M18-2.5 x 140 BOLT	4
<b>112132</b>	M18-2.5 NUT	4
<b>112133</b>	M18 WASHER	8

<b>152501B-777</b>		
<b>P/N</b>	<b>ITEM DESCRIPTION</b>	<b>QTY</b>
<b>110220</b>	M14-2.0 x 100 BOLT	3
<b>110222</b>	M14-2.0 NUT	3
<b>110223</b>	M14 WASHER	6

<b>152501C-777</b>		
<b>P/N</b>	<b>ITEM DESCRIPTION</b>	<b>QTY</b>
<b>150201-100-HW</b>	COMPRESSION ARM	1
<b>110227</b>	M12-1.75 x 110MM BOLT	4
<b>110243</b>	M12-1.75 NUT	4

<b>152501F-777</b>		
<b>P/N</b>	<b>ITEM DESCRIPTION</b>	<b>QTY</b>
<b>112142</b>	M10-1.5 X 25MM BOLT	4

<b>152501G-777</b>		
<b>P/N</b>	<b>ITEM DESCRIPTION</b>	<b>QTY</b>
<b>110232</b>	M8-1.0 X 16MM BOLT	4
<b>110233</b>	M8-1.0 NUT	4
<b>110245</b>	M8 WASHER	8

<b>152501D-777</b>		
<b>P/N</b>	<b>ITEM DESCRIPTION</b>	<b>QTY</b>
<b>110287</b>	M10-1.5 x 130MM BOLT	2
<b>110223</b>	M14 WASHER	8
<b>110222</b>	M14-2.0 NUT	8

<b>152501J-777</b>		
<b>P/N</b>	<b>ITEM DESCRIPTION</b>	<b>QTY</b>
<b>110230</b>	M10-1.25 X 25MM	4
<b>110244</b>	M10-1.25 NUT	4
<b>110239</b>	M10 WASHER	8

# Crossmember Cut Template

Scale to print vertical height of 209mm

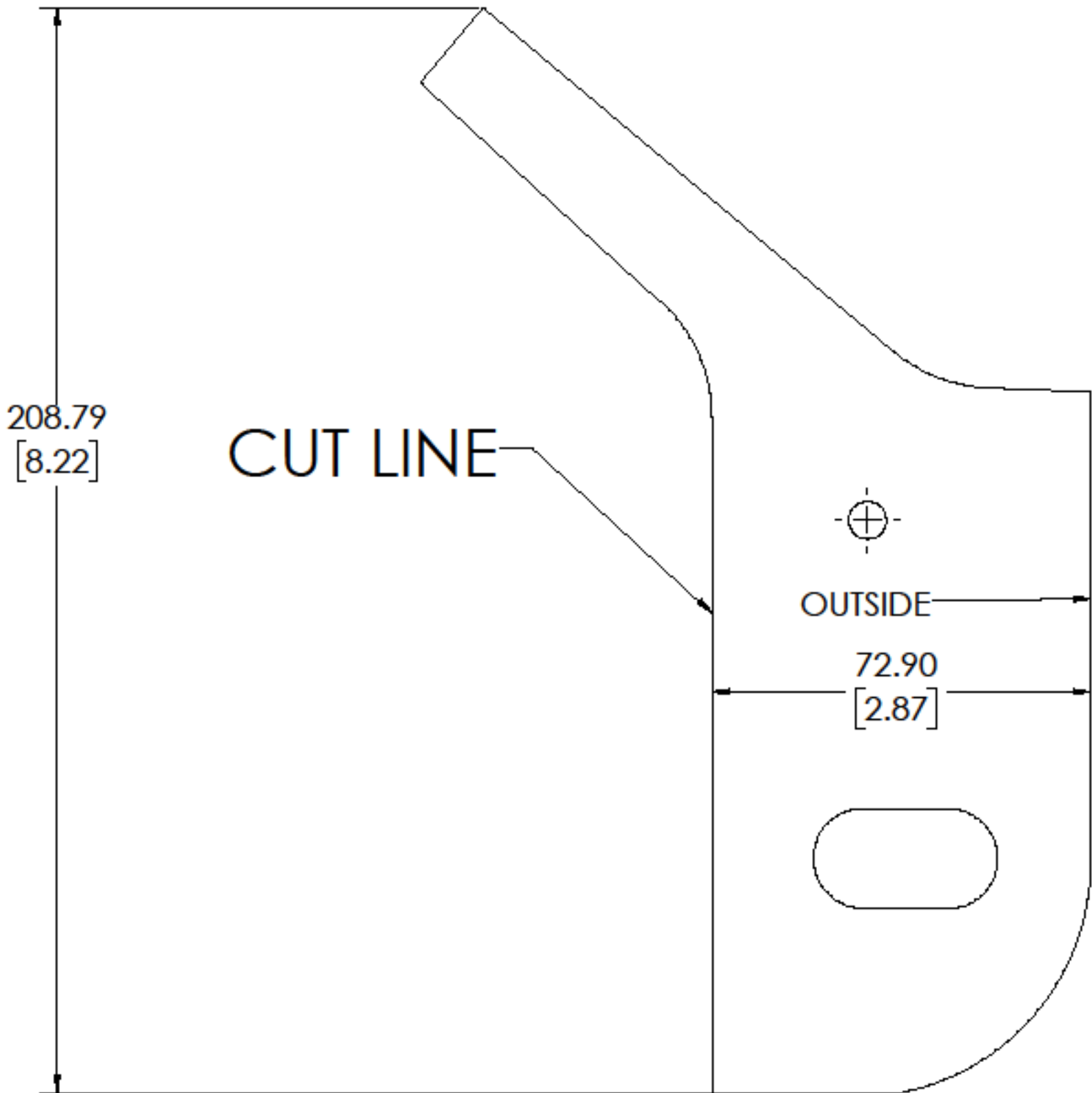



# INSTALLATION GUIDE

**PART NUMBER: 15301**  
**5" TO 7" LIFTING COILOVER**  
**FORD F-150 2WD/4WD | 2015 TO 2020**

This coilover kit was designed to be used with Belltech lift kit number 152501. It cannot be used alone to achieve a 5" to 7" lift. It may be used on a vehicle that has been lifted 5" to 7" using another brand. However, Belltech has not tested cross-compatibility with other brands and cannot speak to how well each will work together.

300 W. PONTIAC WAY. CLOVIS, CA 93612  
PHONE: 800-445-3767 | EMAIL: [INFO@BELLTECH.COM](mailto:INFO@BELLTECH.COM)

# THANK YOU

Thank you for choosing our high quality Belltech product. We have spent a great deal of time developing our line of products so that you will receive maximum performance with minimal difficulty during installation. Soon your vehicle will be on the road looking and feeling much improved.

**Please take a moment to read all instructions and warnings prior to installation of your new Belltech product and before operating your vehicle. If you have any questions or concerns regarding any step in the installation process, please do not hesitate to call or email our customer support specialists who are trained to help you through any portion of this process.**

## Before You Begin:

**It is of the utmost importance that you confirm all of the components listed on the parts list is in the kit. You can find this list located on the last page(s) of your instructions. Do not begin installation if any part is missing. Instead, please call our Belltech customer service specialists.**

### Belltech Customer Support:

Phone: 1-800-445-3767

Email: [info@belltech.com](mailto:info@belltech.com)

## Safety Information:

**Warning:** Do not work under a vehicle supported only by a jack. Place support stands securely under the vehicle in the manufacturer's specified locations unless otherwise instructed.

Proper use of safety equipment and eye/face/hand protection is absolutely necessary when performing any of the following instructions.

We strive for an exceptional experience for all our valued customers. If for any reason you need assistance with your Belltech products, please do not return the product to the store you purchased from, but rather call our dedicated customer service experts, from 6am to 5pm PST.

We recommend that a qualified mechanic, at a properly equipped facility, perform this installation.

It is very helpful to have an assistant available during installation.

## Before Driving Your Vehicle:

It is important to double check all brake hoses, cables, and other components to be sure there is no interference. You must also check for wheel/tire to chassis/body interference. If any issues are found, review your installation instructions to be sure no steps were missed and any problems are corrected.

Make sure your vehicle is aligned immediately following installation.

Check all hardware and re-torque at intervals for the first 10, 100, and 1000 miles.

Some of Belltech's products are designed to improve your vehicle's off-road performance. Leveling/lifting your vehicle may result in an altered center of gravity. It is crucial to use extreme care when operating your vehicle to prevent rollover and/or loss of control.

Any changes in your vehicle's suspension may result in transformed handleability. Please test-drive your vehicle in a remote location so you can become accustomed to the revised driving characteristics.

Perform headlight check and adjustment.

Failure to drive any modified vehicle in a safe manner may result in harm or death.

Never operate your modified vehicle under the influence of drugs, alcohol, or lack of adequate sleep.

Always wear your seatbelt.



**DIFFICULTY:**

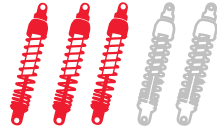

**INSTALLATION TIME:**

2-4 Hours + Alignment

## RECOMMENDED TOOLS:

- Properly rated floor jack
- Support stands
- Wheel chocks
- Metric socket wrench set
- Metric wrench set
- Tape measure
- Marking Pen

## SPECIALTY TOOLS:

- High quality spring compressor
- Torque wrench up to 200ft/lbs



### Technician note:

Before making any adjustments to your new Belltech coilover, please be sure to loosen the set screw. Failure to do so will damage the threads. After the adjustments are made, you may then tighten the set screw to keep the settings in place.

## INSTALLATION PREPARATION:

Before beginning the installation process, measure the hub to fender heights for your vehicle and record them in the “Before” section. After your vehicle has been modified, record the new measurements in the, “After” section. This way, you can compare the resulting height to the original. When taking the measurements, measure vertically from the center of the wheel to the inner edge of the fender.

**Before:**

LF: \_\_\_\_\_

RF: \_\_\_\_\_

LR: \_\_\_\_\_

RR: \_\_\_\_\_



**After:**

LF: \_\_\_\_\_

RF: \_\_\_\_\_

LR: \_\_\_\_\_

RR: \_\_\_\_\_

## JACKING, SUPPORTING, AND PREPARING THE VEHICLE

1. Park your vehicle on a smooth, level, concrete or seasoned asphalt surface.
2. Block the rear wheels of the vehicle using wheel chocks. Make sure the vehicle's transmission is in "PARK" (automatic) or 1st gear (manual).
3. Activate the parking brake.
4. Loosen, but do not remove, the front wheel lug nuts.
5. Lift the front of the vehicle off the ground using a properly rated floor jack. Lift the vehicle so the front tires are approximately 6-8 inches off the ground.
6. Place support stands rated for the vehicles weight. The stands should be positioned in the factory specified locations. (Refer to owners manual). Prior to lowering the vehicle onto stands, make sure the support stands will contact the chassis. It is very important that the vehicle is properly supported to prevent any harm to ones self or to the vehicle.
7. Lower the vehicle slowly onto the stands.
8. Remove the front wheels.



### Technician reminder:

Never work under a vehicle supported only by a jack. It is necessary to place support stands securely under the vehicle in the manufacturer's specified locations unless otherwise instructed.

## OEM STRUT REMOVAL

9. Using a marking pen, mark the alignment cams to reference placement later.



10. Working on one side at a time, loosen and remove the lower control arm bolts that connect the lower control arm and frame.

11. Loosen and remove the nuts securing the lower strut mount to the control arm.



12. Push the lower control arm down until the lower strut studs are clear of the control arm.



13. Remove the three flanged nuts that secure the top of the strut to the chassis using an 18mm wrench.



# OEM STRUT REMOVAL CONTINUED

14. Carefully drop the strut out of the strut tower



# BELLTECH COILOVER HEIGHT SETUP AND ASSEMBLY

15. The coilover comes as shown below. Remove the nylock nut from the top of the Belltech coilover.



16. Using the table below as reference, remove the main spring and slide the required packers onto the strut rod.

2015 to 2020 Ford F-150 2WD/4WD		
Lift (Inches)	Perch height (milli-meters/inches)	15mm Packer
+5	357mm/14.1in	0
+6	375mm/14.8in	1
+7	393mm/15.5in	2

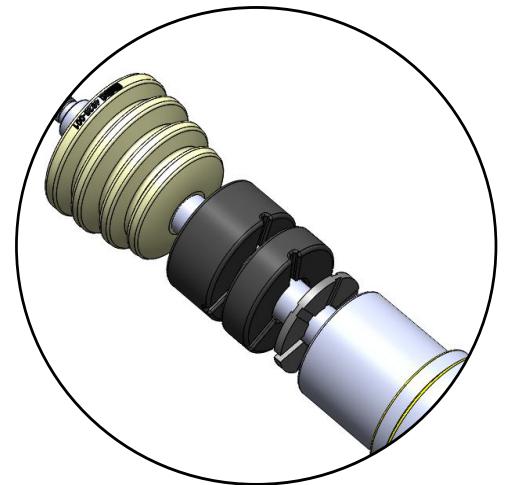

### Technician note:

Belltech uses packers to maintain the correct bump stop engagement at various height ranges. Using the appropriate packer will prevent excessive body roll. If a packer is needed, according to the above charts, please place the packer on top of the vent disc, channel side down, as shown by the image to the right of this text box.

## BELLTECH COILOVER HEIGHT SETUP AND ASSEMBLY CONTINUED

17. Confirm the vent disk is located on the strut, under the dust boot. If for any reason your vent disk is not present, please call our technical support staff before proceeding, as driving on the strut without it could cause the shock to fail.
- 18. Loosen the set screw on the spring perch.**
19. Using the provided spanner wrench, turn the bottom spring perch to obtain desired spring perch height, measuring from the top of the perch to the center of the bushing. Find the appropriate spring perch height by referencing the tables above. We do not recommend adjusting beyond what is shown on the tables, as the performance of the shock may decrease greatly.
20. Tighten the set screw.
21. Place the Belltech upper spring seat onto the OE top mount.
22. Assemble the helper spring, intermediate ring, main spring, upper spring seat and OE top mount onto the Belltech coilover.
23. Torque the supplied nylock nut onto the strut. Reference the OE strut markings and ensure the top mount is oriented in the same fashion it was before disassembly.

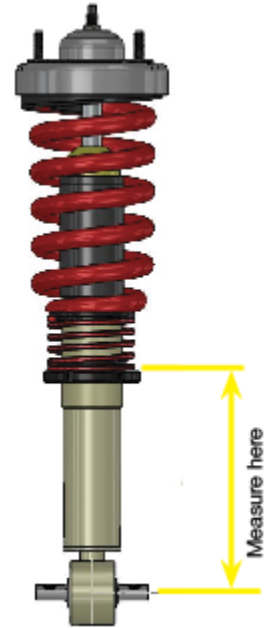

## COILOVER INSTALLATION

24. Install the top mount into the chassis and secure using the OE nuts. Torque the nuts to factory specifications.

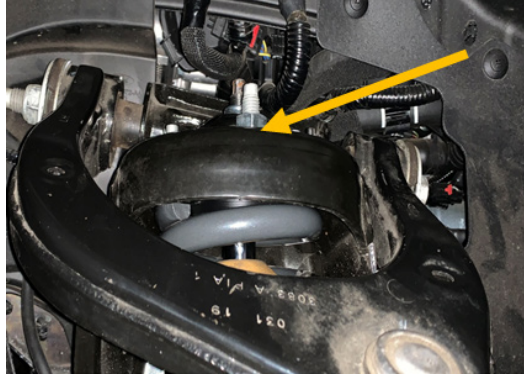

25. Attach the lower strut mount to the lower control arm using the supplied bolts, washers and Nylock nuts. Torque to factory specifications.

26. Reattach the lower control arm to the frame using the OE alignment hardware. Do not tighten or torque until your vehicle is back on the ground.

27. Set the alignment settings to the markings made before installation.

# FINALIZING THE INSTALLATION

28. Re-install the wheels and tighten the lug nuts.
29. Lift the vehicle and remove the support stands.
30. Carefully lower the vehicle onto the flat ground.
31. Torque the lug nuts to manufacturer's specifications.
32. Check that all components and fasteners have been properly installed and torqued.
33. Re-read and perform all tasks in the "Before Driving Your Vehicle" section of page 1 of your instructions.



belltechsuspension



Belltech Suspension



@belltechsuspension

## THANK YOU FOR CHOOSING BELLTECH.

You are now a part of the Belltech family and we are eager to catch a glimpse of your newly modified vehicle. Give us a shout out and let us know how much you love our product. Don't forget, we offer other Belltech related merchandise for you and your vehicle on our website, [www.belltech.com](http://www.belltech.com)!

If you have any questions, concerns, or warranty related issues regarding your Belltech product, please call or email our experienced customer service specialists.

### Belltech Customer Support:

Phone: 1-800-445-3767

Email: [info@belltech.com](mailto:info@belltech.com)

# KIT CONTENTS



15301		
Part number	Description	Qty
15301-100	Belltech Coilover	2
68510039	Spanner Wrench	1
25007-777	Hardware Kit	2

25007-777 Hardware Kit		
Part number	Description	Qty
112307	Bolt Flanged Hex	2
112308	Flanged Nylock Nut	2

15301-100		
Part number	Description	Qty
15301-245	Top Spring Perch Adapter	1
65210800	Dust Boot	1
15002105	Vent Disc	1
65210799	Bump Stop	1
4935-001	15mm Packer	2
65050577	Upper Spring Seat	1
15001-003	Coilover Spring Adapter	1
15001275	Top Mount	1
68320103	Set Screw M5x12	1
70130-330-993	Belltech Linear Spring	1