



INSTALLATION INSTRUCTIONS 150210BK / 150210SP / 150210SPS

300 W. Pontiac Way Clovis, CA 93612 toll free: 1-800-445-3767 web: www.belltech.com

2019+ GM1500 SILVERADO / SIERRA 2WD / 4WD ** EXCLUDING 2019 CLASSIC BODY STYLE**

Thank you for being selective enough to choose our high quality BELLTECH PRODUCT. We have spent many hours developing our line of products so that you will receive maximum performance with minimum difficulty during installation

Note: Confirm that all of the hardware listed in the parts list is in the kit. **Do not** begin installation if any part is missing. Read the instructions thoroughly before beginning this installation.

Warning: DO NOT work under a vehicle supported by only a jack. Place support stands securely under the vehicle in the manufacturer's specified locations unless otherwise instructed.

Warning: DO NOT drive vehicle until all work has been completed and checked. Torque all hardware to specified values.

Reminder: Proper use of safety equipment and eye/face/hand protection is absolutely necessary when using these tools to perform procedures!

Note: It is very helpful to have an assistant available during installation.

Note: Please refer to component and hardware list before beginning installation to insure all necessary pieces have been supplied and packaged.

Exceptional Customer Experience Guarantee:

STOP! We strive for an exceptional experience for all of our valued customers. If, for any reason, you need assistance with your Belltech products, *please do not return the products to the store or website you purchased from.* Please call our dedicated experts at (1-800-445-3767) from 7am to 5pm PST.

RECOMMENDED TOOLS:

- Properly rated floor jack and support stands
- Wheel chocks
- Torque wrench up to 200 ft/lbs range
- Standard and Metric socket wrench set
- Standard and Metric wrench set
- Tape measure
- Dead blow hammer
- Marking pen
- Safety Glasses
- Reciprocating Saw with metal cutting blades

BOX 1: LK1004

PART NUMBER	DESCRIPTION	QUANTITY
150210-101	Front Crossmember	1
150210-102	Rear Crossmember	1
150210-104	Differential Drop	1
150210-110	Tie Rod End	2
150210-888	Instructions	1
150210-777	Hardware Kit	1
150210A-777	Hardware Pack: Front/Rear Crossmember	1
110218	M16 x 2 - 120 Hex Bolt	4
110219	M16 Flat Washer	8
110242	M16 x 2 Nylock Nut	4
150210B-777	Hardware Pack: Differential Drop	1
110220	M14 x 2.0 - 100mm Hex Bolt	2
110221	M14 x 2.0 - 120mm Hex Bolt	1
110222	M14 x 2 Nylock Nut	2
110223	M14 Washer	4
110224	M14 Washer (45-50mm OD)	1
150210C-777	Hardware Pack: Compression Arms	1
150201-100-HW	Bushing Kit	1
110227	M12 x 1.75 - 110 Hex Bolt	4
110228	M12 Washer	8
110243	M12 x 1.75 Nylock Nut	4
150210D-777	Hardware Pack: U-Bolt / Bump Stop	1
110240	9/16"-18	8
110241	9/16" Washer	8
110287	M10 x 1.5 - 130mm	2
150210E-777	Hardware Pack: Replacement Strut Bolts	1
110237	M10 x 1.5 - 70mm Hex Bolt	4
110238	M10 x 1.5 Nylock Nut	4
110239	M10 Washer	8
150210F-777	Hardware Pack: Skid Plate Hardware	1
110226	M12 X 1.75 - 100mm Hex Bolt	1
110225	M12 x 1.75 - 30mm Hex Bolt	1
110243	M12 x 1.75 Nylock Nut	1
110228	M12 Washer	3

BOX 1: LK1004 Continued

PART NUMBER	DESCRIPTION	QUANTITY
150210G-777	Hardware Pack: Rear Brake Line Bracket	1
110232	M8 x 1.0 - 16mm	2
110233	M8 X 1.0 Nylock Nut	2
110245	M8 Washer	4
150210H-777	Hardware Pack: Front/Rear Brake Brackets	1
110234	M6 x 1.0 - 16mm Hex Bolt	4
110235	M6 x 1.0 Nylock Nut	4
110117	M6 Washer	8

BOX 2: LK1005

150210-107RD	Compression Arm Bracket	1
150210-107RP	Compression Arm Bracket	1
150210-212	Rear Bracket Bracket	1
150210-111	Front Bracket Relocating Bracket	2
150210-211	Rear Diff. Brake Bracket	1
150210-108	Skid Plate	1
150210-201	Lift Block	2
150210-203	Bump Stop Extenders	2
150201-106	Boxed Compression Arms	2
6593-007	9/16" - 18 U-bolts	4

BOX 3: LK2000

150210-103L	Driver Side Lifting Knuckle	1
150210-103R	Passenger Side Lifting Knuckle	1

KIT PREPERATION:

Before beginning the install process, measure the hub to fender heights for your vehicle so you can compare the resulting height to the original. Measure vertically from the center of the wheel to the inner edge of the fender. Record the results here:

LF: _____ RF: _____ LR: _____ RR: _____

Park the vehicle on a smooth, level concrete or seasoned asphalt surface and activate the parking brake. Block the rear wheels of the vehicle with appropriate wheel chocks; making sure the vehicle's transmission is in 1st gear (manual) or " Park" (automatic).

It is very important that the vehicle is properly supported during this installation to prevent personal injury and chassis damage. Make sure that the support stands are properly placed prior to performing the following procedures. We **DO NOT RECOMMEND** using wheel ramps while performing this installation.

FRONT REMOVAL / INSTALL:

1. Jack up the front of the vehicle. Place jack stands under the frame rails and lower onto jack stands letting the front suspension hang.
2. Using a 13mm socket, remove the factory plastic front skid plate. **(PHOTO 1)**
3. Use a 22mm socket to undo the lug nuts and remove the wheels.
4. Remove the sway bar from the vehicle completely by disconnecting it from the end link using an 18mm wrench, and removing the brackets using a 10mm socket. **(PHOTO 2)**
5. Using a 21mm wrench, remove the tie-rod nut. Strike the side of the mount with a dead blow hammer to dislodge the tie rod end. A 10mm wrench may be needed if the ball joint is spinning. **(PHOTO 3)**
6. Using a 10mm wrench, remove brake line and abs sensor wire from the control arm and spindle. Undo the brake caliper mounting bolts with an 18mm socket and remove them, hang the calipers to prevent stretching of the lines using large zip ties or hangers. Remove the rotors by removing the T30 Torx screw and put it to the side. **(PHOTO 4)**
7. Remove ABS sensor from hub with a 10mm socket.

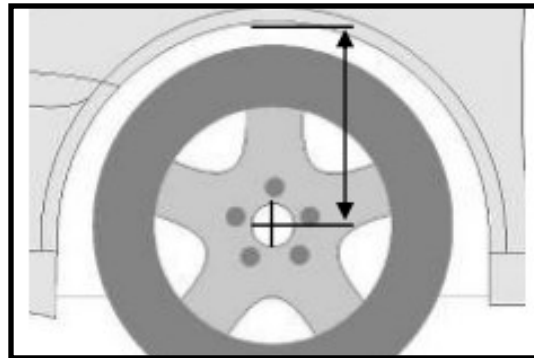

8. Remove the axle nut using a 36mm Socket. This will help prevent the axle from pulling out of the differential and causing damage. **(PHOTO 5)**
9. Support the spindle by gently lifting against it with a jack. This is to prevent the spindle assembly from falling during the next two steps
10. Remove the upper ball joint nut using an 18mm wrench. Strike the spindle on the designated Bosses to help separate the upper control arm from the spindle. Be careful, the upper control arm could be under tension. Allow the spindle to droop as you slide the axle shaft out of the hub. **(PHOTO 6)**
11. Remove the lower ball joint nut using a 24mm wrench and strike it on the designated areas to separate from the lower control arm. Be sure to hold the spindle as it breaks free to prevent damage. **(PHOTO 7)**
12. Uninstall the strut. The top nuts can be removed with an 18mm wrench. Remove the hardware holding the bottom of the strut to the control arm using a 15mm wrench and socket and remove the strut from the vehicle. **(PHOTO 8)**
13. Remove the Lower control arms from the frame using a 27mm Socket and wrench. **(PHOTO 9)**
14. Remove the OEM crossmember underneath the front differential to create clearance for the differential to drop down. All mounting points of the differential can be undone using a 21mm wrench and socket. Use a reciprocating saw to cut the driver side mount as shown in to allow for the differential to clear. **(FIGURE: 1)**

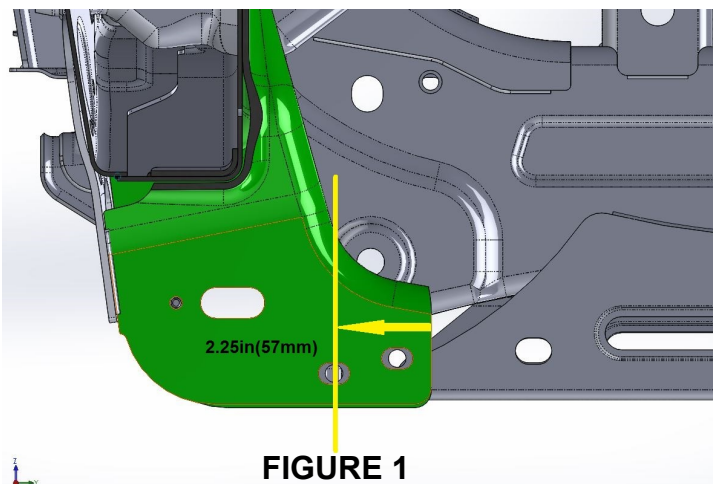
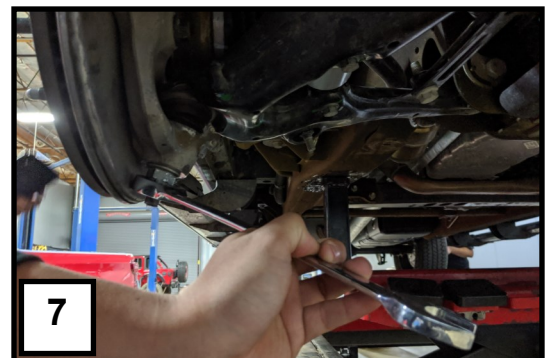
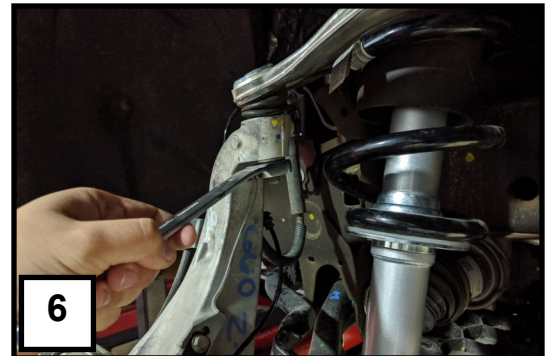

15. Install the rear crossmember using the supplied M16 bolts, washers and nylock Nuts within the **150201A-777** hardware kit. Torque to 180 ft-lbs. **(PHOTO 10)**

16. Place a jack underneath the front differential and remove the hardware mounting the differential to the frame. Lower until it is almost in contact with the rear crossmember

17. Install the differential bracket against the OEM frame mount using the supplied M14x2—120mm bolt and large washer within the **150210B-777** hardware kit. Use a jack, lift the differential into the bracket and secure with the remaining M14 hardware. Using the OEM bolt align the differential and the tabs of the rear crossmember. Tighten all bolts and torque to 120 ft-lbs. **PHOTO 11 (Passenger) / Photo 12 (Drivers)**

18. Install the front crossmember using the remaining M16 hardware from **150210A-777** kit. Torque to 180 ft-lb. Reinstall the lower control arms into the slots in the new crossmembers using the factory hardware. **(Photo 10)**

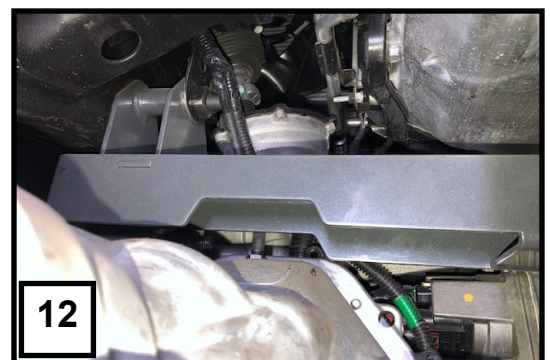
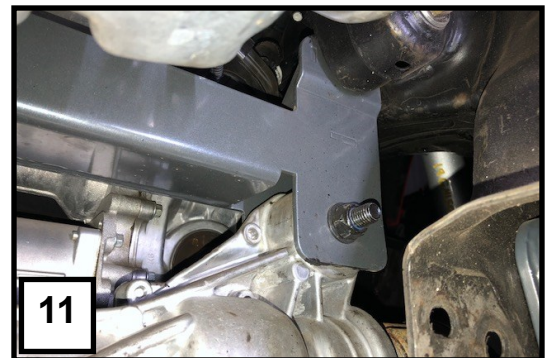
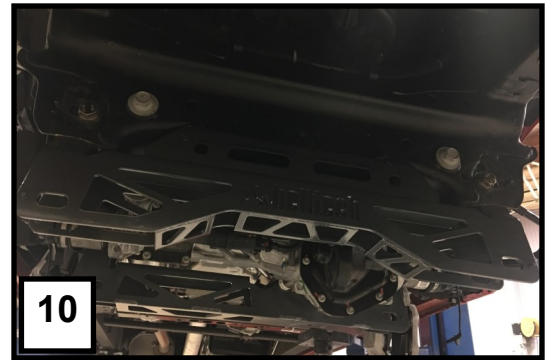

For Strut Spacer Installation:

Please refer to the included instructions for strut spacer 150210-120. All required hardware is provided.

For Trail Performance Strut Installation:

Please refer to the instructions for setting ride height included within the strut 28019.

For both instances use the provided M10 hardware within packet 150210E-777 for mounting the lower bushing to the control arm, bolt head up.

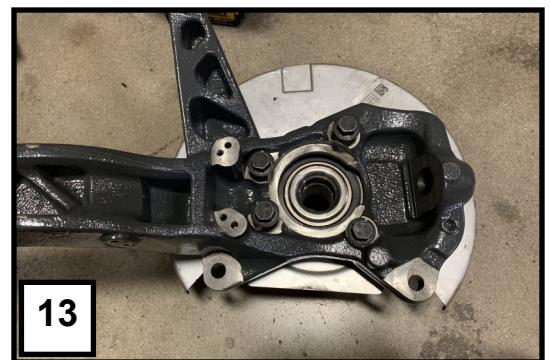

19. Remove the hub and brake backing plate from the factory spindle using an 18mm socket. Install on the Lift Spindle. **(PHOTO 13)**

20. Install the assembled lift spindle in the reverse order of the deinstallation, making sure the axle shaft does not pull out of its mounting point on the differential. Tighten the axle nut to 180ft-lbs.

21. Torque the upper and lower ball joints to 85 ft-lbs.

22. Reconnect the ABS harness, sensor, and brake calipers using the OEM hardware.

23. Reinstall the outer tie rod to the spindle using the factory hardware. Torque to 65 ft-lbs. **(PHOTO 14)**



For Sway Bar Drop Downs:

Please refer to the included instructions for 150210–113.

All required hardware is provided.

For New Sway Bar Installation:

Please refer to the included instructions within the 5426 sway bar kit. All required hardware is provided.

23. After installation of either options, reconnect the sway bar end link using the OEM hardware. Torque to 35 ft-lbs. **(Photo-15)**
24. Install the skid plate using the supplied hardware in kit **150210F-777** and torque to 50 ft-lbs on the front crossmember, and 30 ft-lbs on the rear crossmember. **(PHOTO 16)**
25. Using a 21mm socket remove the two nuts holding the factory crossmember located towards the center of the vehicle and install the rear compression arm bracket. The crossmember does not get removed so removing the bolts is not necessary. Factory hardware is retained. **(PHOTO 17)**
26. Assemble the Compression arms by pushing the bushings and tubes found in hardware kit 150201-100-HW.. Once assembled mount the compression arms into the brackets and use the hardware supplied in the 150210D-777 hardware pack mount them. Torque to 60 ft-lbs. **(PHOTO 18)**
27. Mount the brake line to the upper control arms as shown using the front brake line relocation bracket and the M6 hardware found in 150210H-777. **(PHOTO 19)**
28. Lower the front of the vehicle to the ground . The front installation is complete. Check that all hardware is torqued and installed properly.



Rear Installation:

29. Chock the front wheels to prevent the vehicle from moving while the rear end is lifted
30. Jack up the rear of the vehicle from the differential.
31. Place jack stands under the frame rails and lower the vehicle onto the jack stands carefully.
32. Remove the wheels.
33. Remove the bolts holding the rear brake line bracket located on the inside of the frame using a 13mm socket. Keep the hardware as it will be reused. It is helpful to locate the brake line holders and to undo them to create slack. This prevents overstretching of any lines during the installation. **(PHOTO 20)**
34. Remove the bolts holding the rear brake line bracket located on top of the rear differential using a 10mm socket. Keep the hardware as it will be reused **(PHOTO 21)**
35. Remove the factory shock absorbers using a 21mm wrench & socket. The factory hardware will be reused.
36. Remove the factory u-bolts by evenly undoing the nuts using a 21mm socket, then remove the factory blocks. Slowly lower the axle to allow for the new 3" block to be installed. **(PHOTO 22)**
37. Install the block on the factory spring pad with the flat part of the block on the spring and the tapered end towards the front. Jack up the axle to meet the springs, making sure to align the center pin. **(PHOTO 23)**
38. With the floor jack applying slight pressure to the rear axle to keep the pin aligned, install the new supplied u-bolts and tighten in a crossing pattern, using the **150210D-777** hardware packet.
39. Uninstall the Bump stops using a 10mm socket, and re-attach them with the supplied bump stop extenders and allen head bolt found in packet **150210D-777**. **(PHOTO 24)**

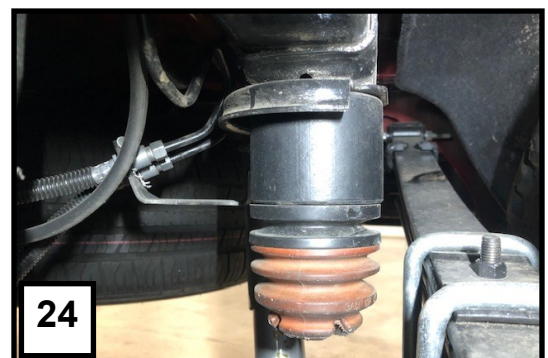

40. Install the new shock absorbers in the factory mounting locations using the factory hardware. Tighten using a 21mm wrench & socket. **(PHOTO 25)**

41. Install the extended brake line located on top of the differential using the factory hardware to mount it to the differential and the supplied bolts and nuts within **150210H-777** to mount the brake lines to the bracket. **(PHOTO 26)**

42. Install the Extended brake line bracket located on the rear of the frame as shown. Use the factory hardware to mount the bracket and the supplied hardware within **150210G-777** to mount the OEM bracket to the drop down. **(PHOTO 27)**

43. Reattach the brake lines and harness wherever it was undone from its factory locations to create slack. Ensure that once reinstalled, none of the brake lines are being stretched before continuing.

44. Install the tires/wheels.

45. Jack up the vehicle to remove the jack stands. Remove the jack stands and lower the vehicle to the ground.

46. Torque the wheels and rear installation is now complete.





INSTALLATION GUIDE

PART NUMBER: 15303
FRONT COILOVER KIT
GM 1500 TRUCK 2WD / 4WD | 2019-2024

+6" TO +8" HEIGHT ADJUSTABLE

****DESIGNED TO BE USED WITH BELLTECH LIFT KIT 150210TPC AND 150210HK****

300 W. PONTIAC WAY. CLOVIS, CA 93612
PHONE: 800-445-3767 | EMAIL: INFO@BELLTECH.COM

THANK YOU

Thank you for choosing our high quality Belltech product. We have spent a great deal of time developing our line of products so that you will receive maximum performance with minimal difficulty during installation. Soon your vehicle will be on the road looking and feeling much improved.

Please take a moment to read all instructions and warnings prior to the installation of your new Belltech product and before operating your vehicle. For any questions or concerns regarding the steps in the installation process, please do not hesitate to call or email our customer support team who are trained to help you through any portion of this process.

Before You Begin:

It is of the utmost importance that you confirm all of the components listed on the parts list is in the kit. You can find this list located on the last page(s) of your instructions. Do not begin installation if any part is missing. Instead, please call our Belltech customer service specialists.

Belltech Customer Support:

Phone: 1-800-445-3767

Email: info@belltech.com

Safety Information:

Warning: Do not work under a vehicle supported only by a jack. Place support stands securely under the vehicle in the manufacturer's specified locations unless otherwise instructed.

Proper use of safety equipment and eye/face/hand protection is absolutely necessary when performing any of the following instructions.

We strive for an exceptional experience for all our valued customers. If for any reason you need assistance with your Belltech products, please do not return the product to the store you purchased from, but rather call our dedicated customer service experts, from 7am to 5pm PST.

We recommend that a qualified mechanic, at a properly equipped facility, perform this installation.

It is very helpful to have an assistant available during installation.

Before Driving Your Vehicle:

It is important to double check all brake hoses, cables, and other components to be sure there is no interference. You must also check for wheel/tire to chassis/body interference. If any issues are found, review your installation instructions to be sure no steps were missed and any problems are corrected.

Make sure your vehicle is aligned immediately following installation.

Check all hardware and re-torque at intervals for the first 10, 100, and 1000 miles.

Some of Belltech's products are designed to improve your vehicle's off-road performance. Leveling/lifting your vehicle may result in an altered center of gravity. It is crucial to use extreme care when operating your vehicle to prevent rollover and/or loss of control.

Any changes in your vehicle's suspension may result in transformed handleability. Please test-drive your vehicle in a remote location so you can become accustomed to the revised driving characteristics.

Perform headlight check and adjustment.

Failure to drive any modified vehicle in a safe manner may result in harm or death.

Never operate your modified vehicle under the influence of drugs, alcohol, or lack of adequate sleep.

Always wear your seatbelt.



DIFFICULTY:

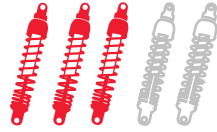

INSTALLATION TIME:

2-4 Hours + Alignment

RECOMMENDED TOOLS:

- Properly rated floor jack
- Support stands
- Wheel chocks
- 1/2" or 3/8" drive wrench
- Metric socket wrench set
- Metric wrench set
- Tape measure
- Marking Pen

SPECIALTY TOOLS:

- High quality spring compressor
- Torque wrench up to 200 ft lbs.

FITMENT NOTE:

This Belltech coilover does NOT fit Models with ARC or Magnetic Ride Shocks.

This Belltech coilover will NOT add the stated additional lift to Chevy Trail Boss / GMC Elevation Models with the 2" Factory Lift.

This Belltech coilover was designed to work specifically with Belltech lift kit 150210TPC and 150210HK to achieve accurate height adjustments, suspension travel, and alignment specifications. Installing this strut in any other lift kit may cause results to vary*

DO NOT drive your 4WD vehicle over 50 mph / 80 km/h while in 4H Auto/ 4H.

INSTALLATION PREPARATION:

Before beginning the installation process, measure the hub to fender heights for your vehicle and record them in the "Before" section. After your vehicle has been modified, record the new measurements in the "After" section. This way, you can compare the resulting height to the original. When taking the measurements, measure vertically from the center of the wheel to the inner edge of the fender.

Before:

LF: _____

RF: _____

LR: _____

RR: _____



After:

LF: _____

RF: _____

LR: _____

RR: _____

JACKING, SUPPORTING, AND PREPARING THE VEHICLE

1. Park your vehicle on a smooth, level, concrete or seasoned asphalt surface.
2. Block the rear wheels of the vehicle using wheel chocks. Make sure the vehicle's transmission is in "PARK" (automatic) or 1st gear (manual).
3. Activate the parking brake.
4. Break loose, but do not spin the wheel lug nuts to ease in removal when the wheels are in the air.
5. Lift the front of the vehicle off the ground using a properly rated floor jack. Lift the vehicle so the front tires are approximately 6-8 inches off the ground.
6. Place support stands rated for the vehicle's weight. The stands should be positioned in the factory specified locations. (Refer to the owner's manual). Prior to lowering the vehicle onto stands, make sure the support stands will contact the chassis. It is very important that the vehicle is properly supported to prevent any harm to oneself or to the vehicle.
7. Lower the vehicle slowly onto the support stands.
8. Remove the front wheels.



Technician reminder:

Never work under a vehicle supported only by a jack. It is necessary to place support stands securely under the vehicle in the manufacturer's specified locations unless otherwise instructed.

ORIGINAL STRUT REMOVAL

9. Locate the three mounting bolts at the top of the strut. Remove the nuts using an 18mm wrench.

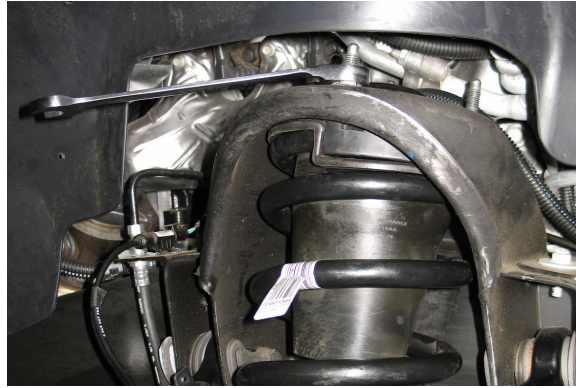

10. Remove the bottom bolts on the original strut and lower control arm using a 15mm wrench.

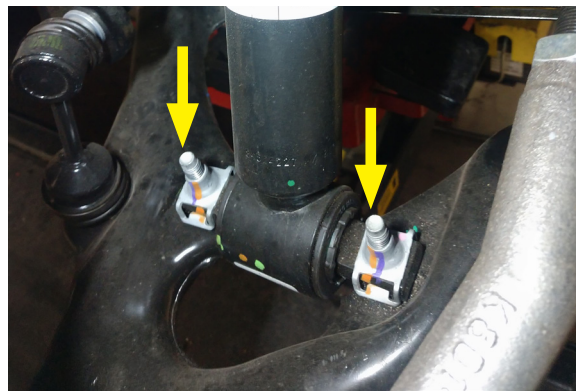

11. Remove the mounting nut holding the sway bar end link to the lower control arm. The nut is located on the underside of the lower control arm. This will allow the lower control arm to swing down and ease the removal of the strut.



12. Push or pry down on the lower control arm to gain clearance and remove the strut front the vehicle.

ORIGINAL STRUT DISASSEMBLY

- Using a proper spring compressor, mount the strut assembly and ensure it is secured before proceeding. To ease the installation of the new Belltech strut, mark the position of the top mount in relationship to the upper spring isolator and strut body.



Technician note:

The installation photograph shown was taken at a professional installation shop. It is important to use a spring compressor to compress the spring before removing the top mount bolt. Failure to do so may result in serious injury.

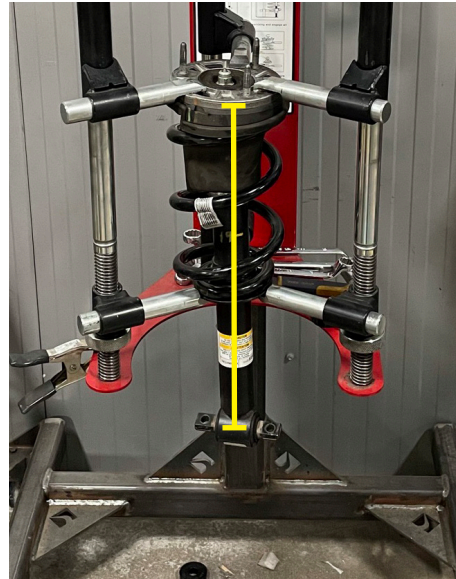

- Compress the spring until tension is relieved from the strut. Remove the 18mm top nut and the top mount. You will use the mount with your new Belltech coilover.



- Remove the spring and strut from the fixture.
- Separate the top mount from the spring isolator using a pry tool or flat head screw driver.



BELLTECH COILOVER HEIGHT SETUP AND ASSEMBLY

17. The coilover is delivered as shown below. Remove the Nyloc nut from the top of the Belltech coilover to proceed.

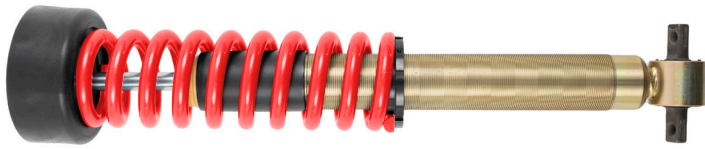

Technician note:

When raising your vehicle more than 1", OE camber may not be achievable. Ensure proper toe alignment to minimize tire wear.

18. Using the table below as reference, remove the main spring and slide the required packers onto the strut rod.

2019+ GM 1500 2WD		
Lift (Inches)	Perch Height "A" Measurement	15mm Packer
6"	294mm / 11.6in	0
7"	310mm / 12.2in	1
8"	326mm / 12.8in	2

2019+ GM 1500 4WD		
Lift (Inches)	Perch Height "A" Measurement	15mm Packer
6"	330mm / 13.0in	0
7"	346mm / 13.6in	1
8"	362mm / 14.3in	2

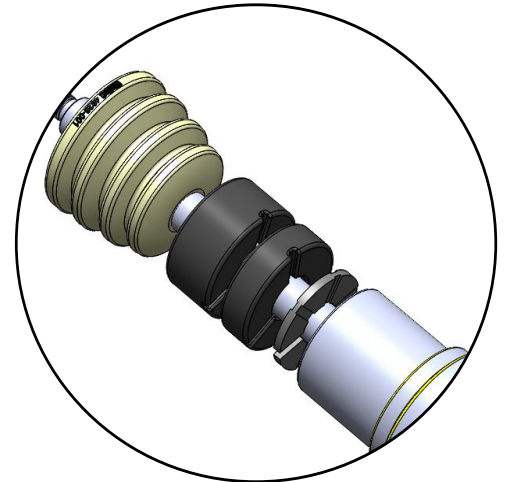

Technician note:

Belltech uses packers to maintain the correct bump stop engagement at various height ranges. Using the appropriate packer will prevent excessive body roll. If a packer is needed, according to the above charts, please place the packer on top of the vent disk, channel side down, as shown by the image to the right of this text box.

19. Confirm the vent disk is located on the strut, under the dust boot. If for any reason your vent disk is not present, please call our technical support staff before proceeding, as driving on the strut without it could cause the shock to fail.
20. Loosen the set screw on the spring perch.
21. Using the provided spanner wrench, turn the bottom spring perch to obtain desired spring perch height, measuring from the top of the perch to the center of the lower bushing. Find the appropriate spring perch height by referencing the tables above. We do not recommend adjusting beyond what is shown on the table as the performance of the shock may decrease greatly.
22. Tighten the set screw. Do not over tighten the set screw. Max torque is 1-2 Nm (1.5 ft-lbs.)

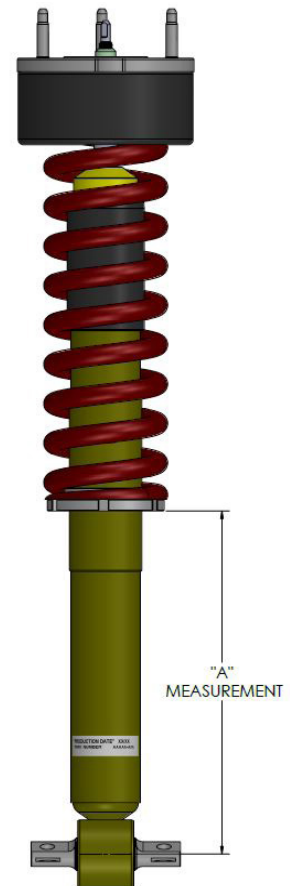

BELLTECH COILOVER HEIGHT SETUP AND ASSEMBLY CONTINUED

23. Place the original top mount onto the Belltech upper spring seat.

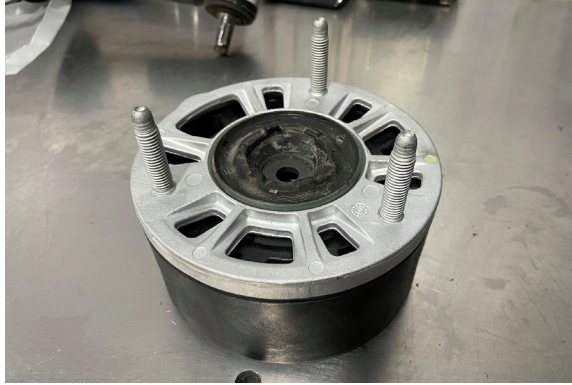

24. Assemble the spring bearing, main spring, upper spring seat, and the original top mount onto the Belltech coilover.

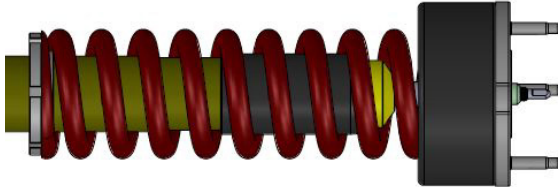

25. Reference the original strut markings and ensure the top mount is oriented in the same direction it was before disassembly. Torque the supplied Nyloc nut onto the strut to 37 ft lbs.

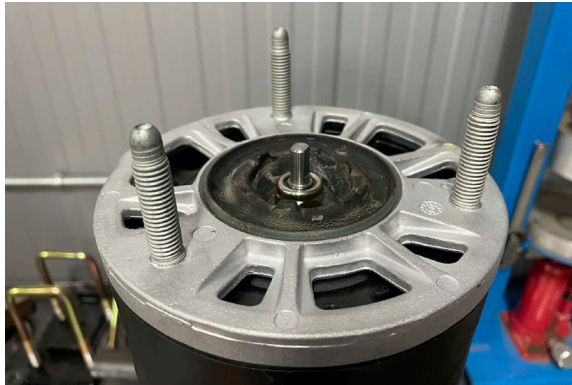

BELLTECH COILOVER INSTALLATION

26. Install the top mount into the chassis and secure the coilover using the three OEM nuts. Torque to 43 ft lbs.



27. Attach the lower strut mount to the lower control arm using the supplied M10x1.50-70mm bolts, M10 washers, and M10 Nyloc nuts. Torque the supplied nuts to 60 ft lbs.

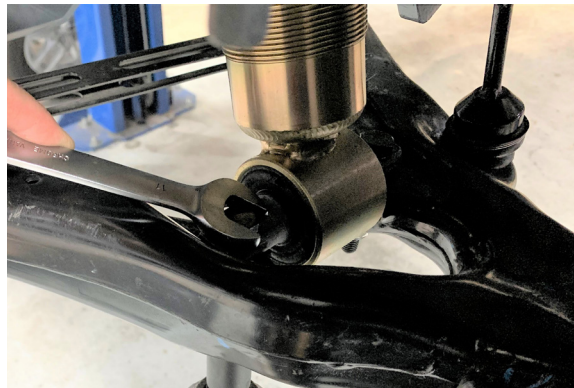

28. Attach the end link to the lower control arm, torque to 74 ft lbs. when the suspension is loaded or the vehicle is back on the ground.



FINALIZING THE INSTALLATION

29. Mount the wheels and tighten the lug nuts.
30. Lift the vehicle and remove the support stands.
31. Carefully lower the vehicle onto the flat ground.
32. Torque the lug nuts to 140 ft lbs.
33. Check that all components and fasteners have been properly installed and torqued.
34. Read and perform all tasks in the “Before Driving Your Vehicle” section of page 1 of your instructions.

THANK YOU FOR CHOOSING BELLTECH.

You are now a part of the Belltech family and we are eager to catch a glimpse of your newly modified vehicle. Give us a shout out and let us know how much you love our product. Don't forget, we offer other Belltech related merchandise for you and your vehicle on our website www.belltech.com

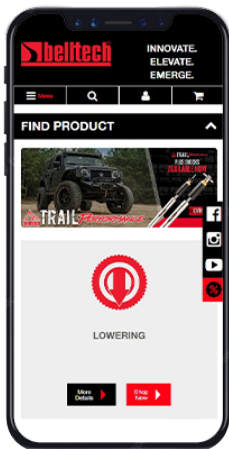

belltechsuspension



Belltech Suspension



@belltechsuspension

If you have any questions, concerns, or warranty related issues regarding your Belltech product, please call or email our experienced customer service specialists.

Belltech Customer Support:

Phone: 1-800-445-3767

Email: info@belltech.com

KIT CONTENTS



15303		
Part number	Description	Qty
15303-100	BELLTECH COILOVER	2
68510039	SPANER WRENCH	1
112310	NYLOC NUT	6
15303-009-992	ANGLED TOP SHIM	2
150210E-777	HARDWARE KIT	1

HARDWARE KIT 150210E-777		
Part number	Description	Qty
110237	M10 X 1.50 - 70MM BOLT	4
110238	M10 X 1.50 NYLOC NUT	4
110239	M10 WASHER	8

15303-100		
Part number	Description	Qty
15303-134	THREADED DAMPER	1
65210800	DUST BOOT	1
15002105	VENT DISC	1
65210799	BUMP STOP	1
4935-001	15MM PACKER	2
65050018	THREADED SPRING PERCH	1
68320103	M5 X 12 SET SCREW	1
15103-103	UPEPR SPRING ADAPTER	1
70150-330-993	LINEAR SPRING	1
15000-010	COIL SPRING BEARING	1



KW automotive North America, Inc.

300 W. Pontiac Way

Clovis, CA 93612

Phone: +1-559-875-0222

Toll Free: 1-800-445-3767

belltech.com