



INSTALLATION SHEET FOR STAINLESS STEEL MUD FLAP

Congratulations on your purchase of a high quality PUTCO product. Should you need any application or technical assistance, feel free to call us at:

1-800-247-3974

Monday-Friday 8:00 a.m.- 5:00 p.m. (Central Standard Time)

Contact your PUTCO dealer for other quality accessories.
PUTCO Inc. - 216 West First Street - Story City, Iowa 50248

PLEASE READ ALL INSTRUCTIONS BEFORE BEGINNING INSTALLATION AND BE SURE TO CHECK TO SEE THAT ALL PARTS AND HARDWARE ARE INCLUDED.

STEP 1: Remove the protective plastic coating from the mud flap and SS trim.

STEP 2: Apply the protective black edge trim to **ONLY** the outer exposed edge. **SEE FIGURE 1**

STEP 3: Attach the stainless steel trim piece to the bottom of the rubber extension. **SEE FIGURE 1**

**BLACK
EDGE
TRIM**

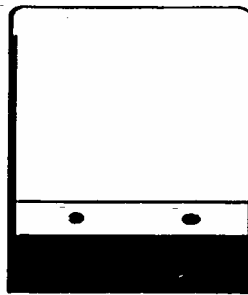
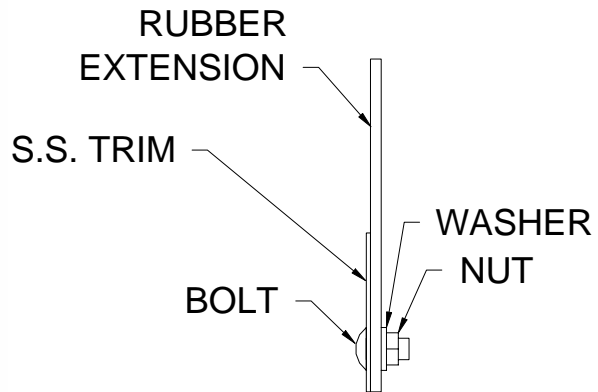
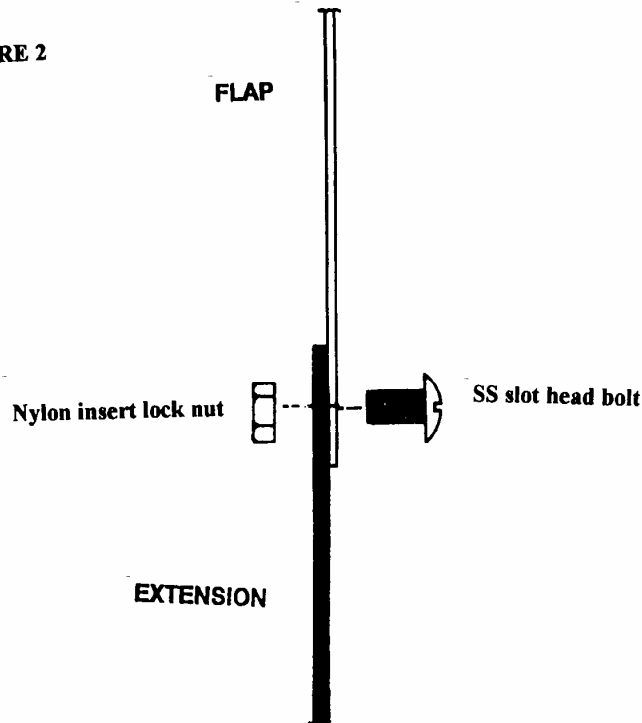

FIGURE 1



STEP 4: Attach the mud flap to the mud flap extension using 1/4" x 3/4" SS slot head bolts and nylon insert lock nuts. **SEE FIGURE 2**

FIGURE 2



92-98 Chevy/GMC, 87-97 Ford, and 81-93 Dodge

STEP 5: Using hex head bolts, lock washers, and nuts, bolt the mounting plate to the long angle bracket. Clamp the mud flap to the long angle bracket **SEE FIGURE 3**

STEP 6: Position mud flap assembly into the fender well and drill two 1/4" holes through the inner fender well lip. Install hex head bolts, lock washers, and nuts. **SEE FIGURE 3**

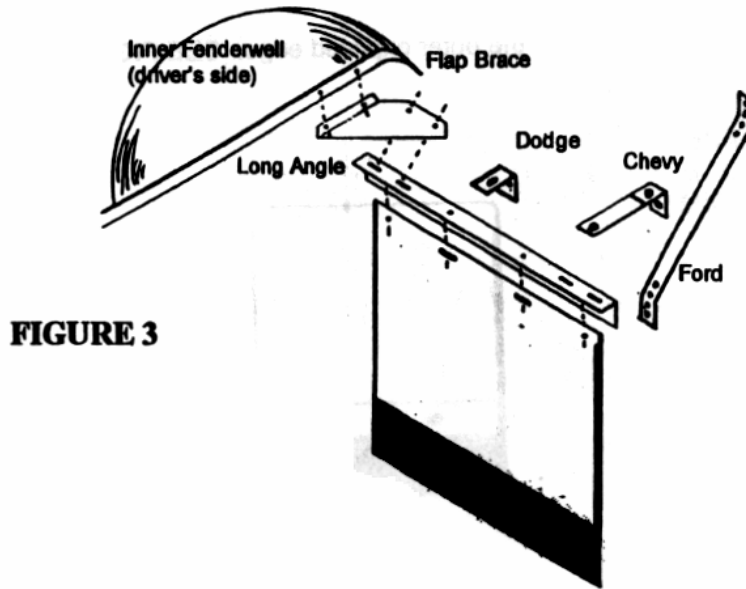

FIGURE 3

STEP 7: Drill four 1/4" holes into the top of the flap and attach it to the long angle bracket. **SEE FIGURE 3**

STEP 8: Bolt on the bracket as shown in **FIGURE 3** for your specific vehicle.

STEP 9: Bolt one end of the brace to an existing bolt in the fender well. The other end bolts to the long angle bracket.

1994-2002 Dodge Ram and 99-UP Ford Super Duty

STEP :5 Drill three 1/4" holes through the inner wheel well flange (this is the metal flange that is part of the truck bed) and the mud flap, attach the flap to the wheel well flange using 1/4" x 1-1/4" SS slot head bolts, lock washers, and hex nuts. In order to see the flange you will have to look from the bumper to the back side of the fender well at ground level.

2001-UP Chevy/GMC Heavy Duty and 2003-up Dodge Ram

STEP 5: Remove the two existing bolts from the fender wheel of your vehicle. Drill two holes in the mud flap using the existing holes as a guide. Attach the flaps to the wheel well using the existing bolts.

Tools Needed
 7/16" wrench and socket
 Flat head screwdriver
 1/4" Drill bit
 Power drill
 Level

LIFETIME WARRANTY

Putco guarantees it's Stainless Steel and Aluminum products against defects in workmanship and material for as long as you own your vehicle. Black products have a 90-day warranty on the painted surface. Any defects resulting from faulty material or workmanship will be warranted by Putco and repaired or replaced at our discretion. Putco assumes no extra labor costs. Damages caused by freight carriers, improper installation, misuse, collision, or neglect will not be warranted by Putco.