

INSTALLATION INSTRUCTIONS



HDX BANDIT REAR BUMPER

APPLICATION:

Chevrolet Silverado/ Sierra 1500 2019-2020 (Excl. 2019 Silverado LD/Limited); 2500/3500 2020

PART NUMBER:

58-341185

CONTENT			
ITEM	QUANTITY	DESCRIPTION	TOOLS NEEDED
1	1	REAR BUMPER	10MM SOCKET
2	1	DRIVER FRAME BRACKET	10MM WRENCH
3	1	PASSENGER FRAME BRACKET	19MM SOCKET
4	1	MAIN DRIVER BRACKET	19MM WRENCH
5	1	MAIN PASSENGER BRACKET	RATCHET
6	1	DRIVER BLIND SPOT MONITOR BRACE	TORQUE WRENCH
7	1	PASSENGER BLIND SPOT MONITOR BRACE	ALLEN
8	1	DRIVER BLIND SPOT MONITOR BRACKET	13MM SOCKET
9	4	SENSOR L-TAB	13MM WRENCH
10	12	M12 SPLIT LOCK WASHER	
11	16	M12 FLAT WASHER	
12	4	M12 HEX HEAD BOLT	
13	12	M12 HEX NUT	
14	2	M6 BUTTON HEAD BOLT	
15	14	M6 FLAT WASHER	
16	2	M6 SERRATED FLANGE NUT	
17	12	M6 CARRIAGE BOLT	
18	12	M6 SPLIT LOCK WASHER	
19	12	M6 HEX NUT	
20	2	M5 BUTTON HEAD BOLT	
21	4	M5 FLAT WASHER	
22	2	M5 NULON HEX NUT	

ANTI-SEIZE LUBRICANT MUST BE USED ON ALL STAINLESS STEEL FASTENERS TO PREVENT THREAD DAMAGE AND GALLING

ITEM 1

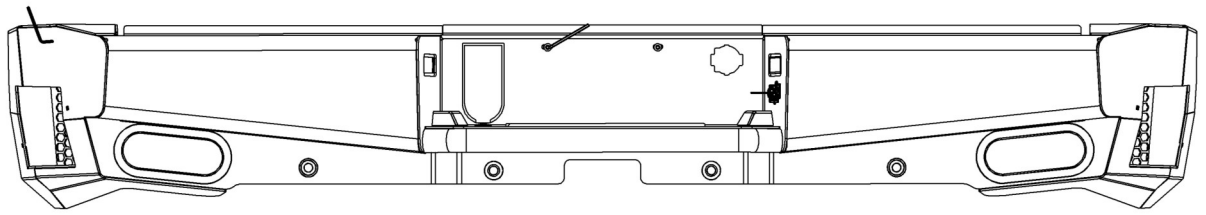

ITEM 2

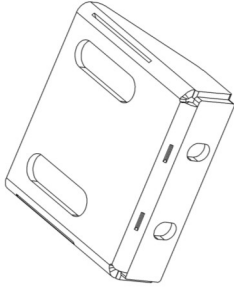

ITEM 4

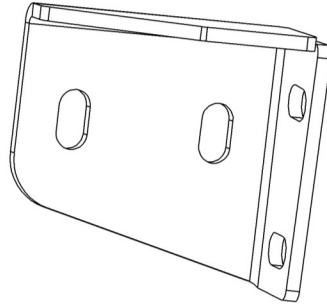

ITEM 8

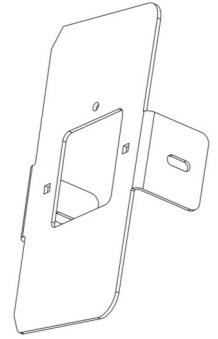

ITEM 9

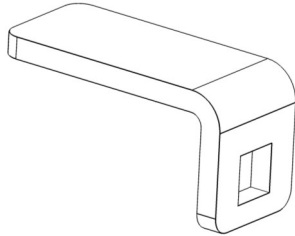

ITEM 10

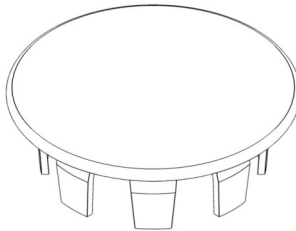

ITEM 6

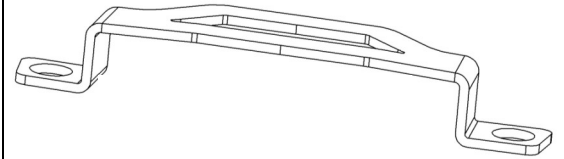

PROCEDURE

1. Remove contents from box, verify if all parts listed are present and free from damage.
Carefully read and understand all instructions before attempting installation.
Failure to identify damage before installation could lead to a rejection of any claim.

2. Remove all electrical connections from the rear bumper.
3. Remove the two nuts and two bolts on each side of the rear bumper. See **Figure 1-2**
4. Remove support tubes on both sides of the bumper.
5. Remove the rear bumper.

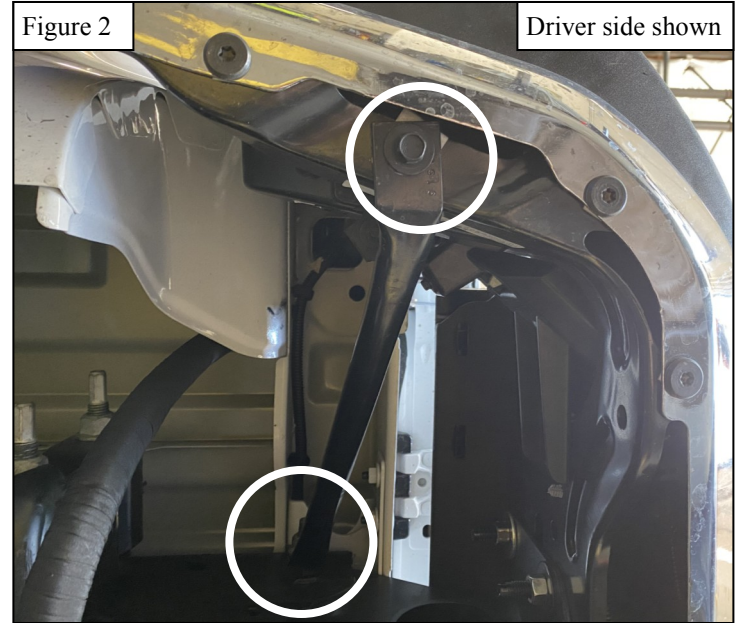

6. Install parking sensors by inserting into the holes on bumper and pressing with sensor L-tabs against bumper plate. Fasten L-tabs with the supplied M6 hardware (15, 17-19). See **Figure 3**.
Note: Be sure to maintain the orientation of the sensor so that it remains consistent with its original orientation.
7. Tighten M6 hardware to 5-7 ft-lbs. *Note: if sensors are not equipped, install the supplied sensor plugs into the holes.*

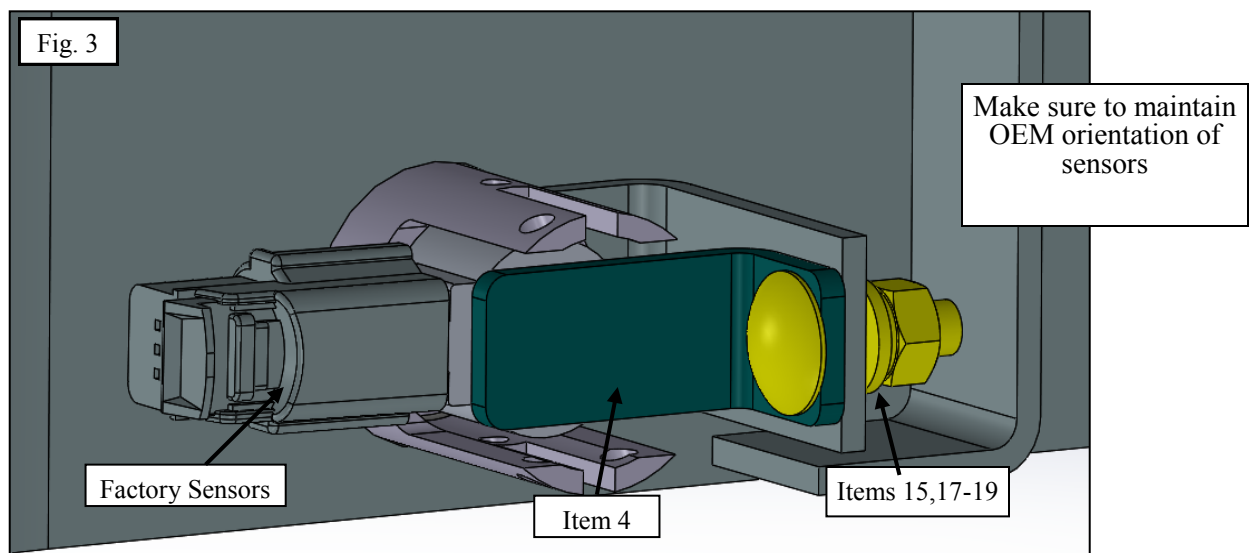
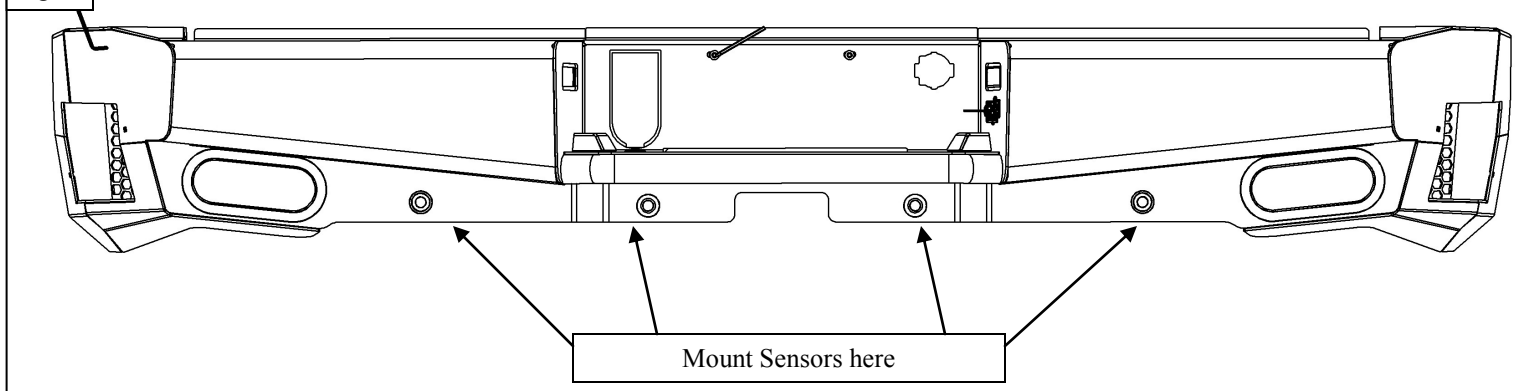
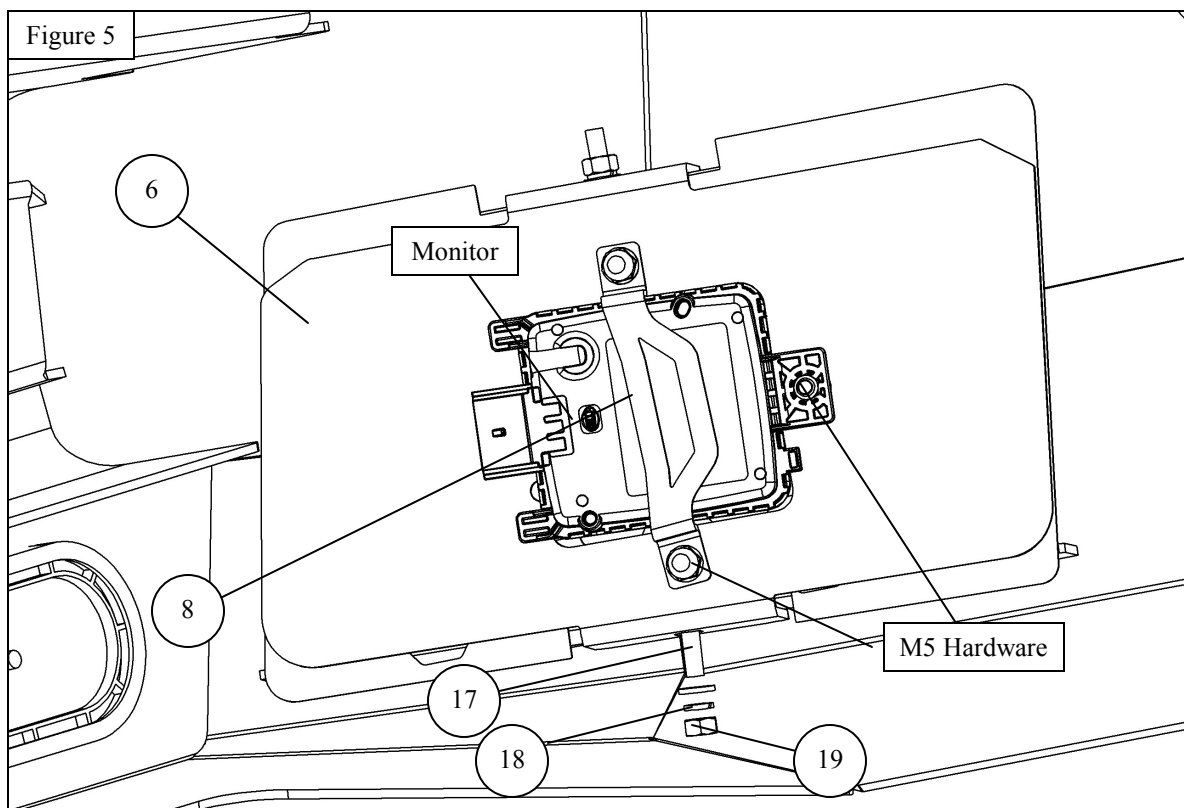

Fig. 4



8. **If blind spot monitor is equipped**– Remove the blind spot monitor from the OE bumper. Remove the cover on the bumper and install the monitor. **See Figure 5**
If blind spot monitor is not equipped- Leave cover attached on bumper and proceed to the next step.

Figure 5



9. Using the supplied M12 hardware, loosely install bumper brackets on to the bumper. Then loosely assemble the bumper to the frame brackets. See Figures 6-7.

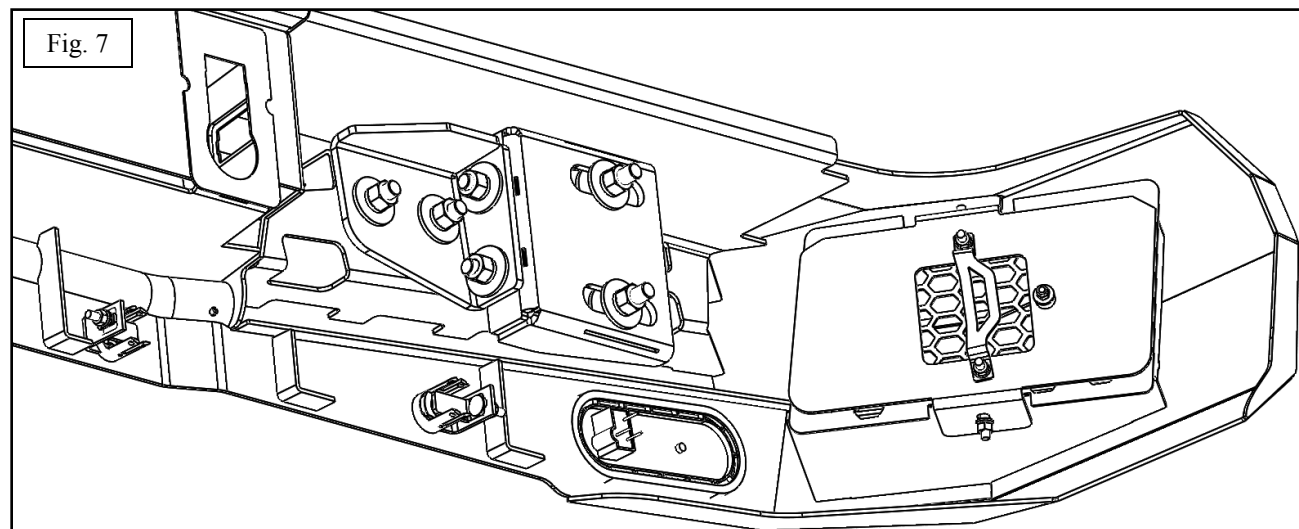
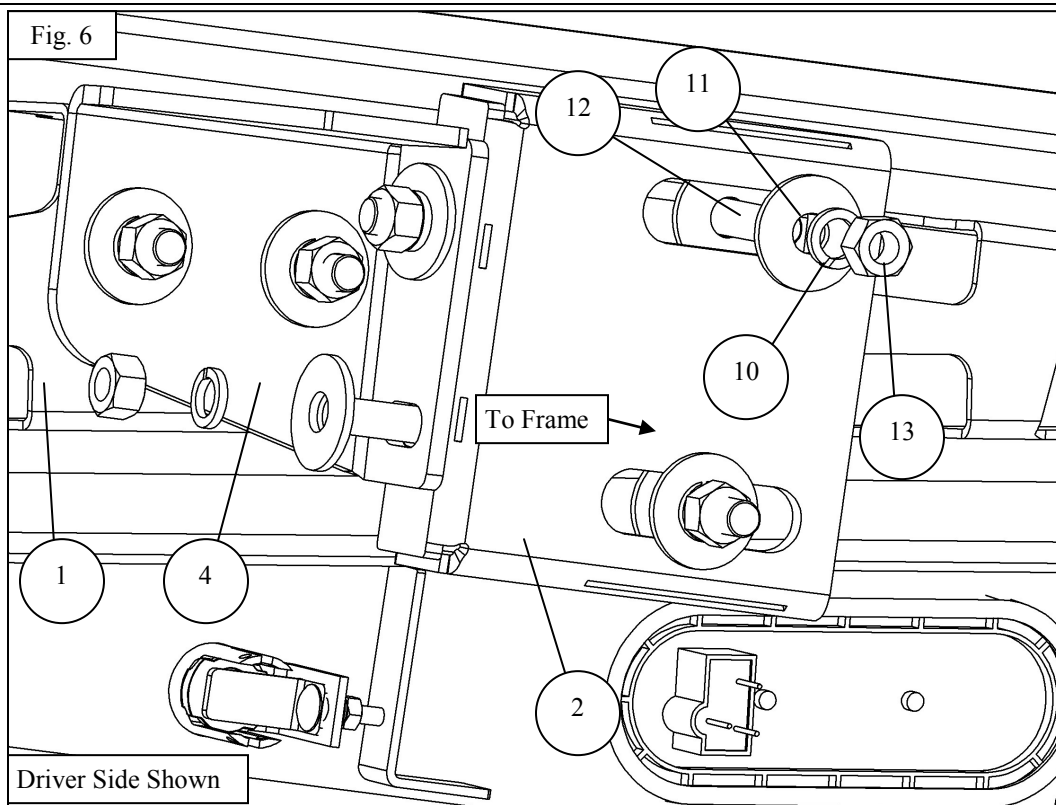

9. Install the Trailer plug and license plate at this time.
10. Install the accessory back up lights if equipped.

WARNING .

After you have mounted bumper on main brackets. **CAREFULLY** open tailgate. While tailgate is open, adjust the height of the bumper so that it has about 3/8" of clearance with respect to the tailgate. Torque M12 to 50-55 ft-lbs.

INSTALLATION COMPLETE



CARE INSTRUCTIONS

- REGULAR WAXING IS RECOMMENDED. DO NOT USE ANY TYPE OF POLISH OR WAX THAT MAY CONTAIN ABRASIVES.
- STAINLESS STEEL PRODUCTS CAN BE CLEANED WITH MILD SOAP AND WATER. STAINLESS STEEL POLISH SHOULD BE USED TO POLISH SMALL SCRATCHES.
- GLOSS BLACK FINISHES SHOULD BE CLEANED WITH MILD SOAP AND WATER.

WESTIN

Westin Automotive Products, Inc.
320 W. Covina Blvd
San Dimas, Ca. 91773

Thank you for choosing Westin products
for additional installation assistance please call
Customer Service (800) 793-7846

www.westinautomotive.com



WARNING



Failure to follow these instructions could lead to death, personal injury, and / or property damage.

Failure to follow these instructions could lead to death, personal injury, and / or property damage.

FASTENERS:

All Westin supplied fasteners must be utilized and installed in accordance with the installation instructions and apply torque to the specifications as defined. **DOUBLE CHECK ALL FASTENERS BEFORE INITIAL USE, AND PERIODICALLY IN THE FUTURE TO ENSURE PROPER FUNCTION AND SAFETY.**

DRILLING:

Most Westin products do not require drilling for installation. If drilling is defined as required, use caution when drilling a vehicle. **FAILURE TO REVIEW AN AREA TO BE DRILLED MAY RESULT IN PERSONAL INJURY AND/OR INJURY TO OTHERS AS WELL AS VEHICLE DAMAGE.**

EYE PROTECTION:

ALWAYS WEAR SAFETY GLASSES OR GOGGLES DURING THE INSTALLATION PROCESS TO AVOID PERSONAL INJURY.

MAXIMUM TOWING/CARRYING CAPACITY: (if applicable)

The Westin Receiver Hitches will have a visible tow rating label affixed directly on the product. User should never exceed the vehicle manufacturers maximum tow and weight rating regardless of the capacity of the hitch. **FAILURE TO FOLLOW THESE GUIDELINES WILL VOID THE WESTIN WARRANTY AND MAY RESULT IN PERSONAL INJURY AND/OR INJURY TO OTHERS AS WELL AS VEHICLE DAMAGE.**

FOR CALIFORNIA RESIDENTS ONLY-PROP 65 WARNING:

Some products may contain chemicals such as DEHP, which can cause cancer, birth defects or other reproductive harm. For more info go to www.p65warnings.ca.gov



Westin Automotive Products, Inc.
320 W. Covina Blvd
San Dimas, Ca. 91773