

INSTALLATION INSTRUCTIONS



HDX BANDIT REAR BUMPER

APPLICATION:

Ram 1500 2009-2018; 1500 Classic 2019-2020; 2500/3500 2010-2020
(Excludes dual exhaust models)

PART NUMBER:

58-341175

CONTENT			
ITEM	QUANTITY	DESCRIPTION	TOOLS NEEDED
1	1	HDX BANDIT REAR BUMPER	15 MM SOCKET
2	1	MAIN BRACKET DRIVER SIDE	RATCHET
3	1	MAIN BRACKET PASSENGER SIDE	10 MM WRENCH
4	1	FRAME BRACKET DRIVER SIDE	18MM SOCKET
5	1	FRAME BRACKET PASSENGER SIDE	21MM SOCKET
6	4	SENSOR L-TAB	PRY TOOL
7	4	SENSOR PLUG	
8	4	M12 DOUBLE BOLT PLATE	
9	12	M12 SPLIT LOCK WASHER	
10	4	M12 HEX HEAD BOLT	
11	16	M12 FLAT WASHER	
12	12	M12 HEX NUT	
13	2	M6 SOCKET DRIVER BUTTON HEAD BOLT	
14	6	M6 FLAT WASHERS	
15	2	M6 SERRATED FLANGE NUT	
16	4	M6 ROUND HEAD SQUARE BOLT	
17	4	M6 SPLIT LOCK WASHERS	
18	4	M6 HEX NUT	

ANTI-SEIZE LUBRICANT MUST BE USED ON ALL STAINLESS STEEL FASTENERS TO PREVENT THREAD DAMAGE AND GALLING

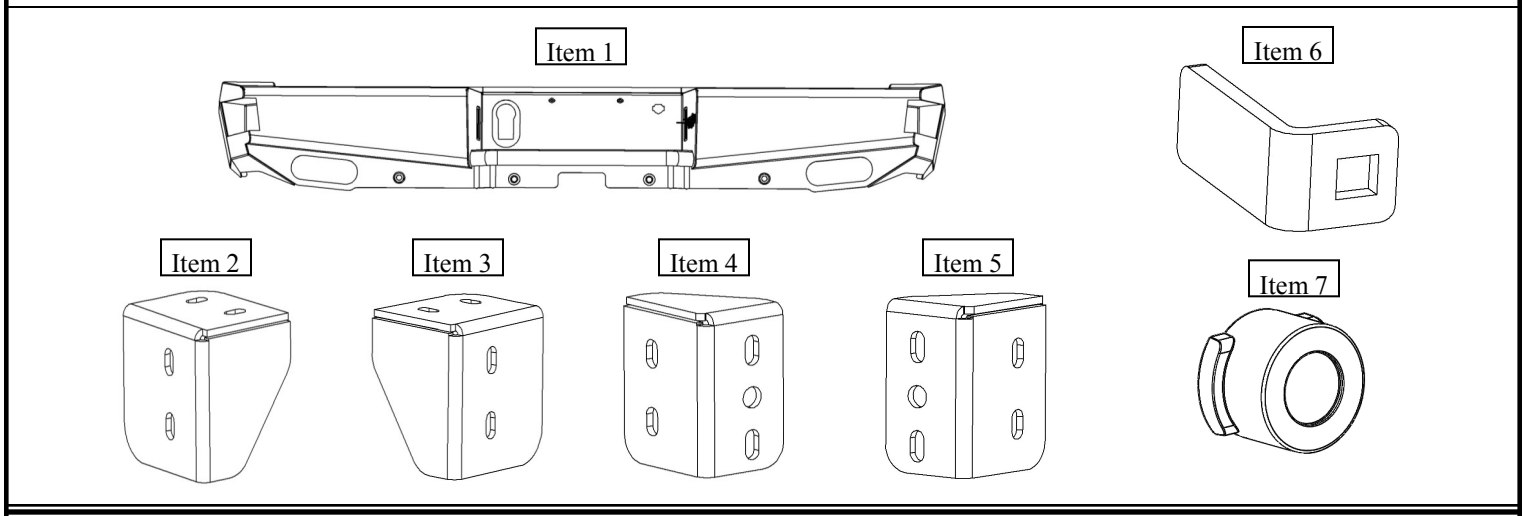

WESTIN Westin Automotive Products, Inc.
320 W. Covina Blvd
San Dimas, Ca. 91773

Thank you for choosing Westin products
for additional installation assistance please call
Customer Service (800) 793-7846

www.westinautomotive.com

DATE: 04/22/20

PROCEDURE

1. Remove contents from box, verify if all parts listed are present and free from damage.
Carefully read and understand all instructions before attempting installation.
Failure to identify damage before installation could lead to a rejection of any claim.
2. Disconnect license plate lights, trailer connector and park assist sensors so that bumper assembly can be removed.
3. Using a 15mm wrench or socket remove the 2 bolts fastened to the bumper behind the license plate and the two plastic pop clips.
4. Using a 15 mm wrench or socket remove 2 bolts fastening the OEM bumper to the bumper mounts (two on each side). See **Figure 1** for reference.

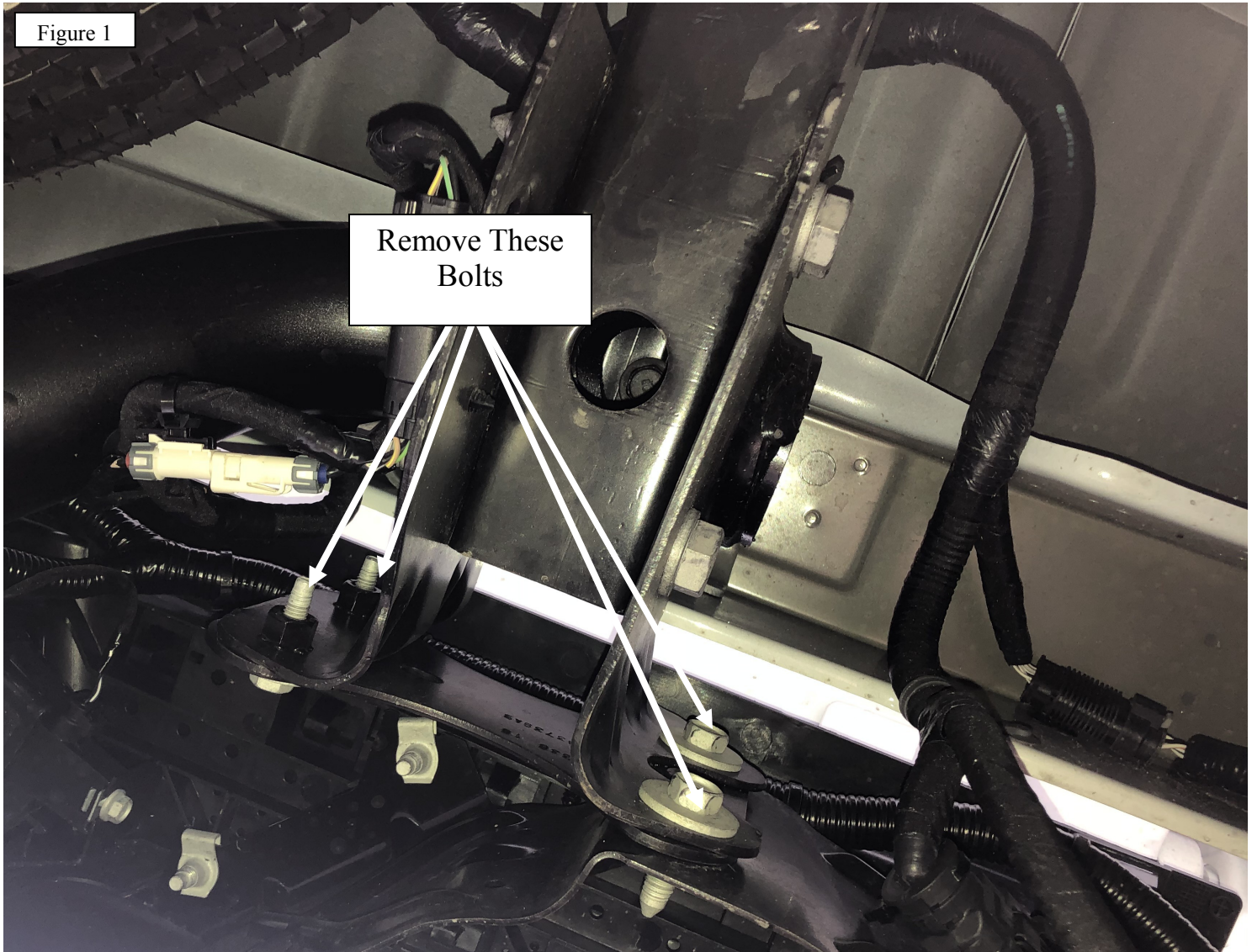

PARKING SENSOR INSTALLATION

***If not installing sensors, install Hole Plugs into holes on bumper and proceed.**

5. Remove the parking sensors from the OEM bumper. Pay attention to the orientation of the sensors. They must be installed in the same orientation. Handle sensors with care, they are very delicate .
6. Use the Sensor Tab (6) along with the supplied M6 Hardware (13, 15-17) to install the sensors as shown in **Figure 2-3**
7. Carefully route the harness around the bumper.

Note: Zip ties or double sided tape can be used to route harness and to hold the sensor in position.

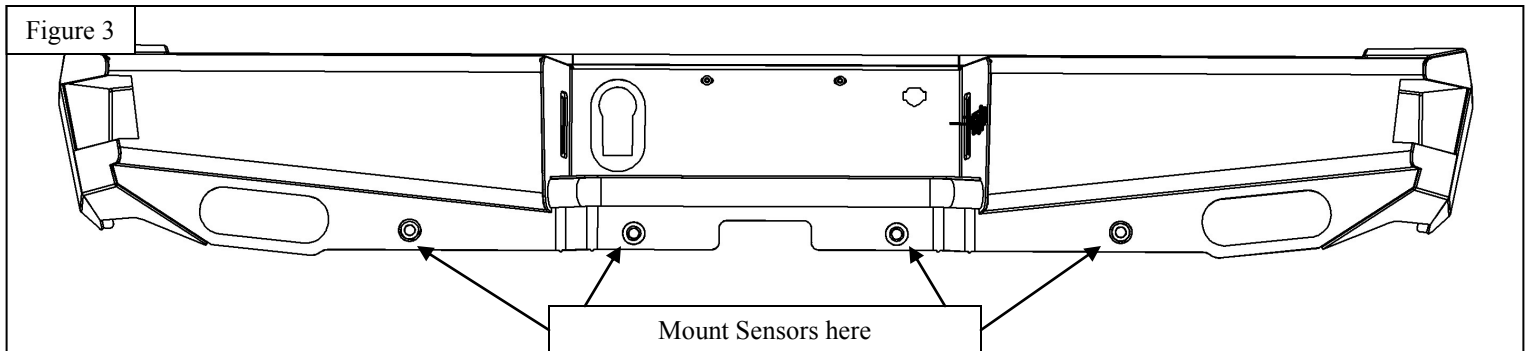
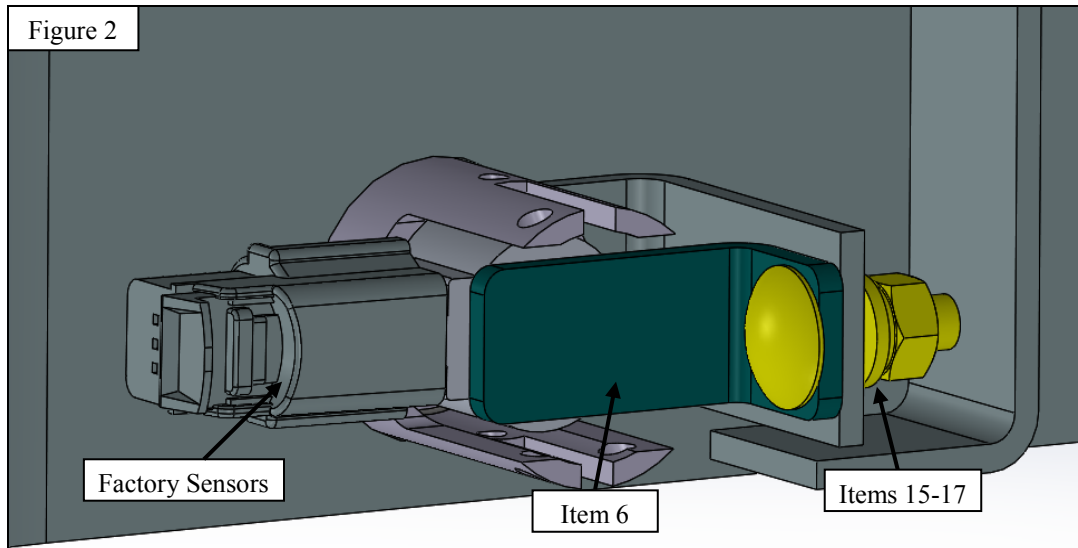

8. Using the supplied M12 hardware, loosely install the bumper to the main mounting brackets (2, 3). See Figures 4-7
9. Use supplied M12 hardware to mount frame bracket items 4 and 5 to frame and hitch.
10. Align and adjust the bumper as needed and make sure that it has enough clearance with open tailgate.
11. Torque all M6 hardware to 7-9 ft-lbs and M12 hardware to 70-80 ft-lbs,

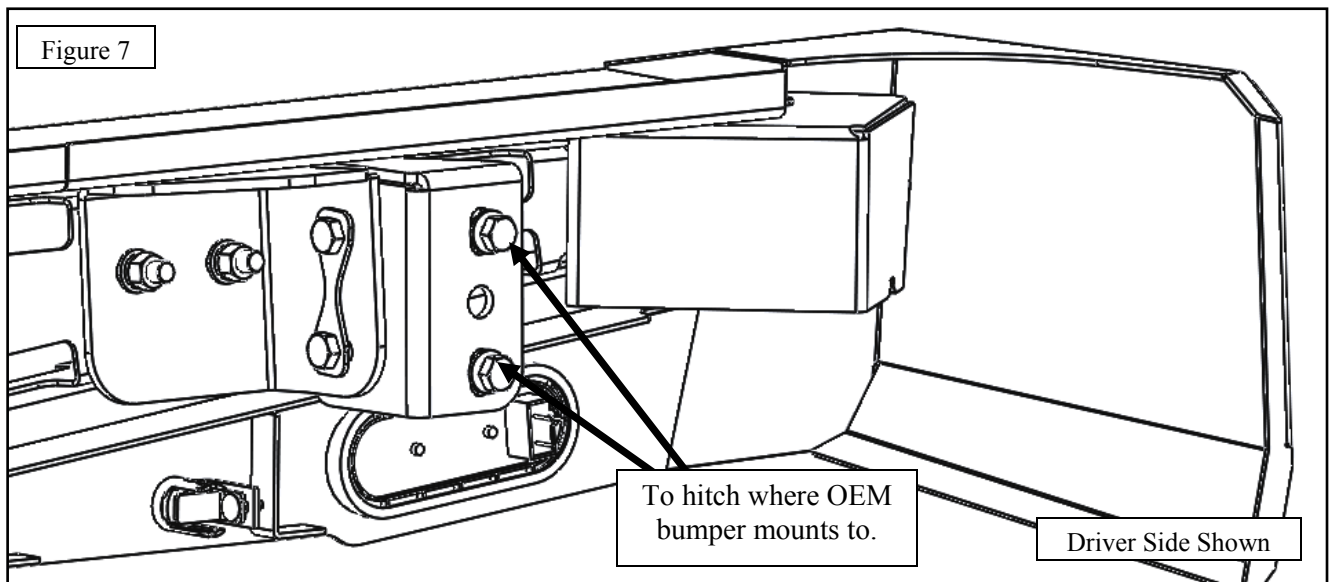
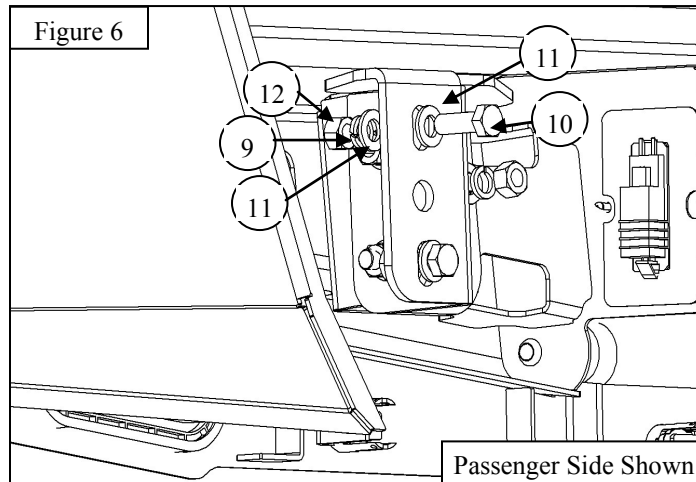
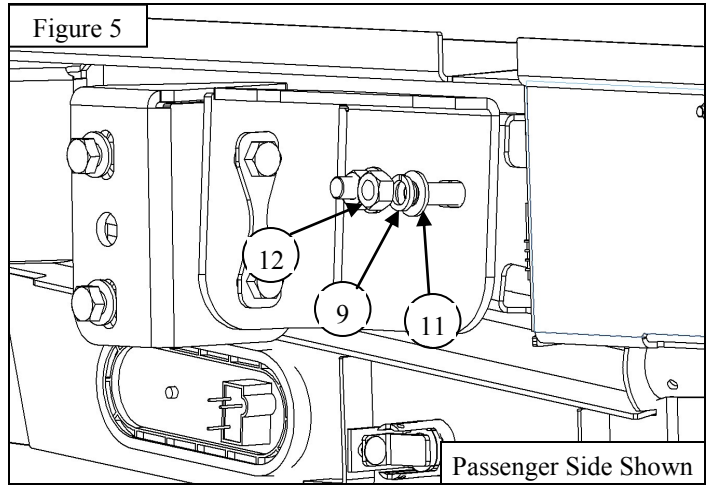
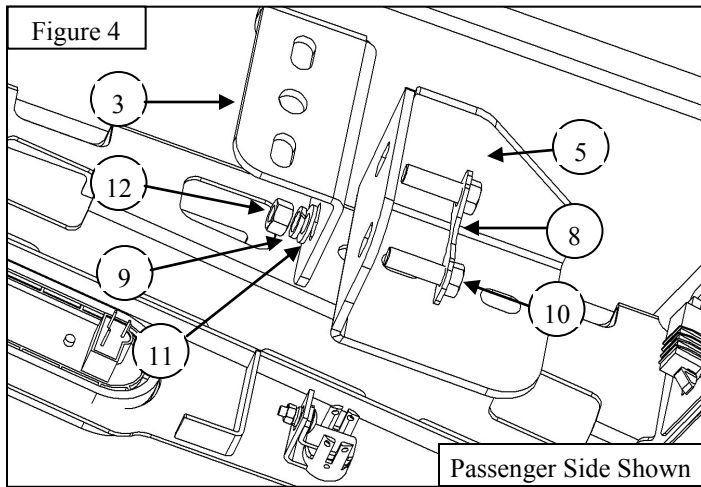

INSTALLATION COMPLETE



CARE INSTRUCTIONS

- REGULAR WAXING IS RECOMMENDED. DO NOT USE ANY TYPE OF POLISH OR WAX THAT MAY CONTAIN ABRASIVES.
- STAINLESS STEEL PRODUCTS CAN BE CLEANED WITH MILD SOAP AND WATER. STAINLESS STEEL POLISH SHOULD BE USED TO POLISH SMALL SCRATCHES.
- GLOSS BLACK FINISHES SHOULD BE CLEANED WITH MILD SOAP AND WATER.

WESTIN Westin Automotive Products, Inc.
320 W. Covina Blvd
San Dimas, Ca. 91773

Thank you for choosing Westin products
for additional installation assistance please call
Customer Service (800) 793-7846



WARNING



Failure to follow these instructions could lead to death, personal injury, and / or property damage.

Failure to follow these instructions could lead to death, personal injury, and / or property damage.

FASTENERS:

All Westin supplied fasteners must be utilized and installed in accordance with the installation instructions and apply torque to the specifications as defined. **DOUBLE CHECK ALL FASTENERS BEFORE INITIAL USE, AND PERIODICALLY IN THE FUTURE TO ENSURE PROPER FUNCTION AND SAFETY.**

DRILLING:

Most Westin products do not require drilling for installation. If drilling is defined as required, use caution when drilling a vehicle. **FAILURE TO REVIEW AN AREA TO BE DRILLED MAY RESULT IN PERSONAL INJURY AND/OR INJURY TO OTHERS AS WELL AS VEHICLE DAMAGE.**

EYE PROTECTION:

ALWAYS WEAR SAFETY GLASSES OR GOGGLES DURING THE INSTALLATION PROCESS TO AVOID PERSONAL INJURY.

MAXIMUM TOWING/CARRYING CAPACITY: (if applicable)

The Westin Receiver Hitches will have a visible tow rating label affixed directly on the product. User should never exceed the vehicle manufacturers maximum tow and weight rating regardless of the capacity of the hitch. **FAILURE TO FOLLOW THESE GUIDELINES WILL VOID THE WESTIN WARRANTY AND MAY RESULT IN PERSONAL INJURY AND/OR INJURY TO OTHERS AS WELL AS VEHICLE DAMAGE.**

FOR CALIFORNIA RESIDENTS ONLY-PROP 65 WARNING:

Some products may contain chemicals such as DEHP, which can cause cancer, birth defects or other reproductive harm. For more info go to www.p65warnings.ca.gov



Westin Automotive Products, Inc.
320 W. Covina Blvd
San Dimas, Ca. 91773