

TITAN pt. no.: 01 0000 0136

Important: Please read these instructions carefully and completely before starting the installation.

TITAN™ Fuel Tanks

INSTALLATION GUIDE



30 Gallon* Spare Tire Auxiliary Fuel System++ (STAFS) for General Motors Diesel-Fueled Vehicles

4010211: General Motors 2500 and 3500 Pickup Models with Duramax Engines for model years 2011-2014

IMPORTANT NOTICE: The Spare Tire Auxiliary Fuel System is to ONLY be installed on vehicles which are equipped with a Class V trailer hitch. All warranties are void if the product is installed on a vehicle which is not equipped with a Class V trailer hitch.

Required Tools:

- 1 ea. Ratcheting socket driver
- 1 ea. SET of metric sockets
- 1 ea. SET of English sockets
- 1 ea. Torque wrench handle and 1 1/8" socket

Recommended Optional Tools:

- 1 ea. Impact wrench
- 1 ea. Vehicle hoist

- 1 ea. Power Drill
- 1 ea. 4.75" Hole Saw
- 1 ea. 3/8" Drill Bit
- 1 ea. 1/4" Drill Bit
- 1 ea. Center punch
- 1 ea. Hammer
- 1 ea. 1/8" Allen Wrench
- 1 ea. Phillips bit screw driver, medium
- 1 ea. Flat blade screw driver, medium size
- 1 ea. 3/8" End Wrench
- 1 ea. Wire Stripper
- 1 ea. Small propane torch to set heat shrink connectors.
- 1 ea. Knife
- 1 ea. Test Light
- 1 ea. Dremel Tool or equivalent
- 1 ea. Pliers, standard
- 1 ea. Pliers, needle nose
- 1 ea. Pliers, large pump

**4010211 TITAN™, 30 Gallon Spare Tire Auxiliary Fuel System (STAFS) with Cross-Linked Polyethylene Tank for FORD vehicles.
Parts List:**

SPARE TIRE TANK BASE PARTS LIST 99 0131 0000		
PART DESCRIPTION	TITAN PART NUMBER	QUANTITY
Spare Tire Tank Body	99 0000 0377	1
1" X 1/2" X 1/2" Double Tapped Tank Bushing	99 0000 0400	1
1/2" Threaded PVC Pipe, 11-1/4" Length	99 0000 0416	1
Rollover Valve, Brass	99 0000 0137	1
Rollover Valve, Brass with Hose	99 0102 0000	1
Electric Fuel Sensor	99 0000 0402	1

SPARE TIRE PUMP KIT PARTS LIST -- 99 0128 0000		
PART DESCRIPTION	TITAN PART NUMBER	QUANTITY
In-Line Fuel Pump	99 0000 0370	1
1/8" NPT to 3/8" Hose Barb Adapter	99 0000 0403	2
Vent Fill Neck Adapter	99 0000 0409	1
3/8" Fuel Hose, 95" Length	99 0000 0419	1
Oval Head Drilling Screw, 8-18 Thread, 1" Length, Zinc-Plated	99 0000 0420	2
5/16" Fuel Hose, 95" Length	99 0000 0421	1

#8 Hose Clamp with 5/16" Band Width	99 0000 0422	9
In-Line Fuel Filter	99 0000 0405	1
1/2" NPT to 3/8" Barbed Hose Eldow, Gray Kynar	99 0000 0401	1
Electronic Controller	99 0130 0000	1
22-18 Gauge Insulated Ring Terminal, 3/8" Stud	99 0000 0264	3
22-18 Gauge Heat-Shrink Butt Splice Terminal	99 0000 0267	6
ATM Fuse Tap	99 0000 0487	1
22-18 Gauge Barrel Quick-Disconnect Terminal	99 0000 0489	1
18 AWG Black Wire, 30" Length	99 0000 0466	2
Polyethylene Electrical Wire Loom, Black, 8 Feet	99 0000 0274	1
18 AWG Blue Wire, 20 ft Length	99 0000 0482	1
18 AWG Purple Wire, 20 ft Length	99 0000 0201	1
#4 Hose Clamp with 5/16" Band Width	99 0000 0483	2
Grounding Wire	99 0120 0000	1
6-32 Machine Screw, 3/16" Length, Zinc-Plated Steel	99 0000 0418	1
Adhesive Backed Velcro (2 Inches)	99 0000 0283	1

UNIVERSAL FILLER NECK KIT PARTS LIST -- 99 0129 0000		
PART DESCRIPTION	TITAN PART NUMBER	QUANTITY
Poly Filler Neck Flange Assembly	99 0134 0000	1
Fuel Cap	99 0000 0368	1
Brushed Aluminum Fuel Door	99 0000 0428	1
Fuel Door Gasket	99 0000 0429	1
10-24 Machine Screw Nut with Tooth Washer, Zinc-Plated Steel	99 0000 0431	5
10-24 Thread, 1" Length, Flat Head Socket Cap Screw, 18-8 Stainless Steel	99 0000 0433	5
5/8" Fuel Hose, 48" Length	99 0000 0434	1
Gasoline Filler Neck Hose - 1 1/2" x 18"	99 0000 0435	1
Molded Gasoline Filler Neck Hose - 1 1/2" x 15 7/8" x 45°	99 0000 0436	1
Molded Gasoline Filler Neck Hose - 1 1/2" x 15 1/8" x 90°	99 0000 0437	1
#28 Hose Clamp with 5/16" Band Width	99 0000 0438	6
#10 Hose Clamp with 5/16" Band Width	99 0000 0439	2
1-1/2" Hose to Hose Coupling	99 0000 0440	2

2011-2014 GM MOUNTING KIT PARTS LIST
Stock #: 4010211 / Kit #: 01 0117 0000

PART DESCRIPTION	TITAN PART NUMBER	QUANTITY
2011-2014 GM Truck Mounting Plate	01 0000 0132	1
2011-2014 GM Tank Mounting Spacer	01 0000 0130	2
3/4"-10 Serrated Flange Hex Locknut, Grade 8	99 0000 0449	3
3/4"-10 Threaded Rod, 16-3/8" Length	01 0000 0134	1
Tank Mounting Plate	99 0000 0407	1
5/16" Flat Washer, Zinc Plated Steel	01 0000 0114	2
5/16"-18 Hex Head Cap Screw, 1-1/4" Length, Zinc Plated, Grade 2	99 0000 0452	2
M10 by 30mm Flange Head Cap Screw, Class 10.9, Black Phosphate Finish	99 0000 0454	1
3/4"-10 Thin Hex Nut, Grade 5 Steel, Zinc Plated	99 0000 0467	1
2011-2014 GM Installation Instructions	01 0000 0136	1
Universal Template for Fuel Door Cutout	99 0000 0480	1

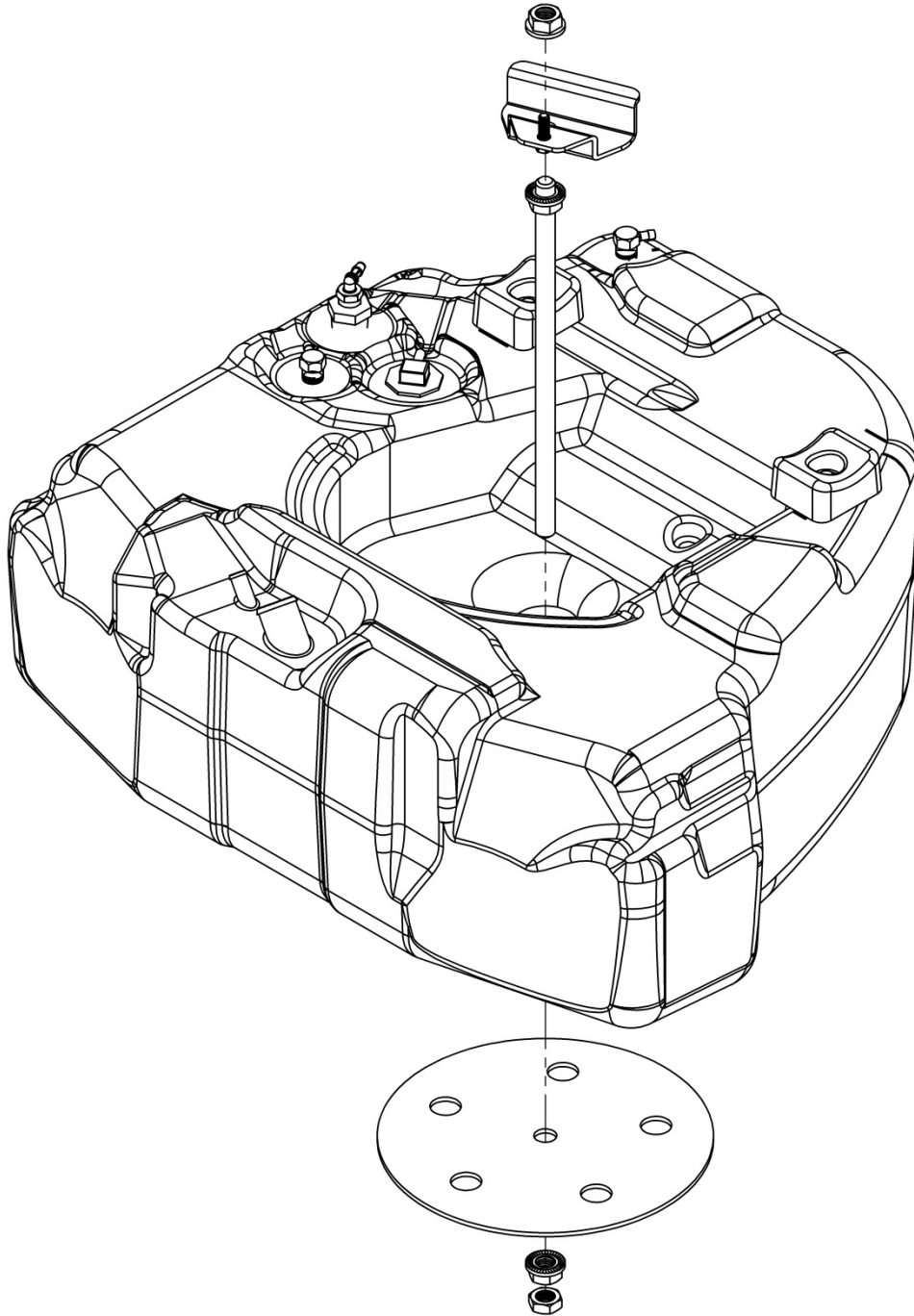

(Fig. 1) Exploded view showing the mounting assembly of TITAN™ model 4010211 Spare Tire Auxiliary Fuel System (STAFS) 30 gallon tank.

I. Remove Vehicle's Spare Tire & Mounting Hardware

<u>Step</u>	<u>Description</u>
1	Lower the spare tire and remove it from the vehicle.

- 2 In a safe and approved manner, place vehicle on hoist and raise to desired working height.
- 3 Remove the vehicle's rear bumper for easy access to the spare tire area.
- 4 Remove the winch assembly that raises and holds the vehicle's spare tire from the vehicle. This should leave a cross member exposed.



(Fig. 2) Cross member in 2011+ GM vehicles showing STAFS top Truck Mounting Plate and Threaded Rod installed.



(Fig. 3) Cross member in 2011+ GM vehicles showing STAFS Truck Mounting Plate close-up.

- 5 Place threaded rod up through Truck Mounting Plate. Using two of the $\frac{3}{4}$ " flanged, serrated nuts provided, fasten it in place. **Screw nut on top of plate so that there are two threads showing above the nut.** Thread bottom nut, up to the bottom of the plate and tighten to 45 ft. lbs. so that the shaft is thoroughly locked in place (See Fig. 4).
- 6 Install Spare Tire Auxiliary Fuel System (STAFS) Truck (top) Mounting Plate on cross member, in place of spare tire winch (See Figs 2 & 3) using M10 flanged cap screw provided. Tighten cap screw securely.

II. Prepare New STAFS Tank for Installation

- 7 Screw in $\frac{1}{2}$ " NPT x $\frac{3}{8}$ " Hose Barb elbow (99 0000 0401) into plated Double Tapped Tank Bushing which is already installed in tank (See Fig. 6) Install $\frac{3}{8}$ " Hose (99 0000 0419) onto barb of the elbow. Use hose clamps on all hoses.

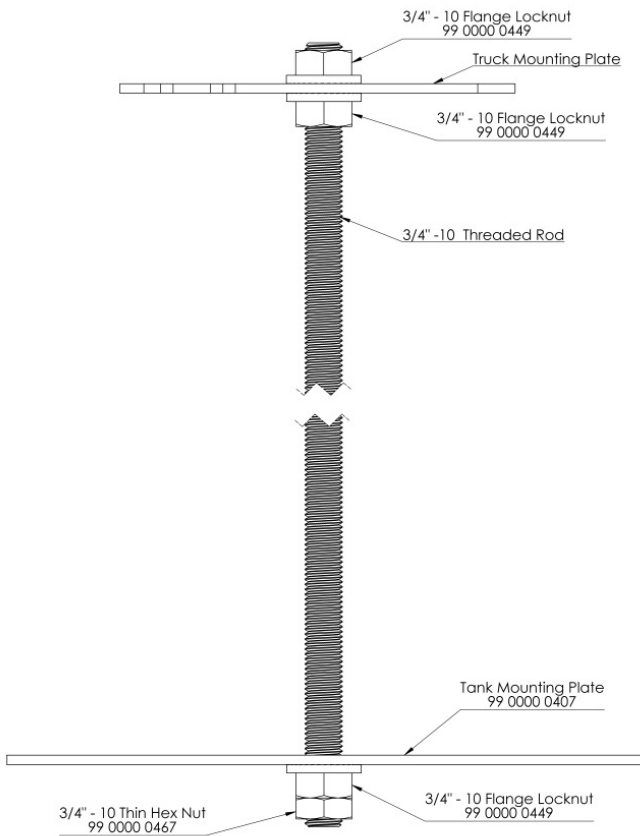

(Fig. 4) Side view of tank mounting plate assembly, threaded rod, and bottom tank mounting plate. Be sure to torque the nuts on the top plate to 45 ft. lbs, the flanged nut on underside of Tank Mounting Plate to 15 ft. lbs. against the tank and the jam nut ("Thin Hex Nut") at the very bottom to 45 ft. lbs.

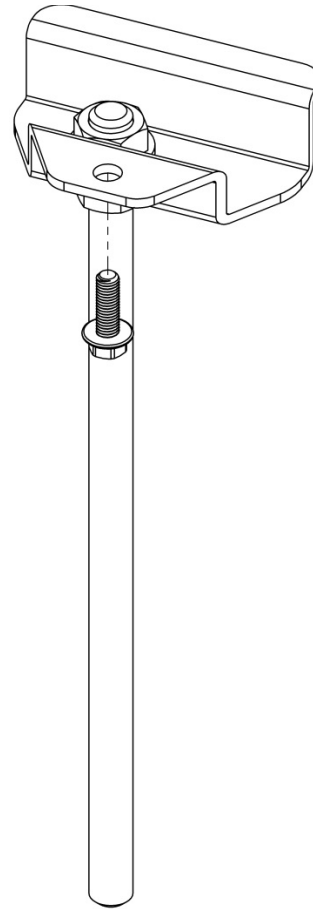

(Fig. 5) Exploded view of Truck Mounting Plate (top plate).



(Fig. 6) Installing 1/2" x 3/8" Hose Barb Elbow into plated Double Tapped Tank Bushing.



(Fig. 7) Install 5/16" hose onto the rollover valve as shown in this photo.



(Fig. 8) Connecting small eyelet end of grounding wire to top of electric fuel sensor. Other end to chassis frame

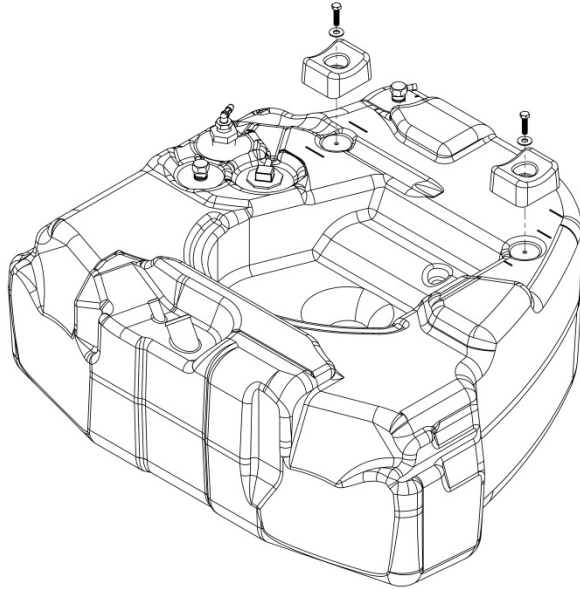

(Fig. 9) Exploded view showing spacers (01 0000 0130) required on 11+ GM attaches vehicles.

- 8 Install 5/16" hose onto the rollover valve (99 0000 0421) which is adjacent to the elbow discussed in Step 7, above (See Fig. 7). Use hose clamps on all hoses.
- 9 Connect small eyelet end of grounding wire (99 0120 0000) to top of electric fuel sensor using 6-32 machine screw (See Fig. 8). The other end will be attached to a substantial place on chassis frame to ground the tank.
- 10 Connect electric fuel sensor leads using supplied heat-shrink butt splice terminals according to wiring diagram in Fig. 10. *Install 2 ea. Spacers (01 0000 0130) on top of tank as shown in Fig. 9 using 5/16" cap screws and washers.*

III. Fit STAFS Tank and Components in Vehicle

- 11 Lift tank into place with Tank Mounting Plate under it on 3/4" threaded rod. Be sure to align circular mounting tabs on the bottom of the tank with the holes in the Tank Mounting Plate. Tighten 3/4" flanged locknut just enough to hold tank snug for now. The hose fittings on the tank are located adjacent to the vehicle's rear bumper.
- 12 Check the path of the 1 1/2" fill hose and 5/8" vent hose (See Fig.11). This path will run from the fittings on the tank to the point where you have decided to install the fuel door. Filler and vent hose will run from tank body, over frame rail, into space in fender behind driver's side rear wheel. NOTE: Some model years may require the trimming of sheet metal or other non-critical structural components to allow clearance for filler and vent hose. Be sure that there are no sharp edges which may rest against any of the hoses (See Figs. 12 & 13). Remove tank and trim the path.

TITAN™ Electronic Controller Pump Wiring Diagram

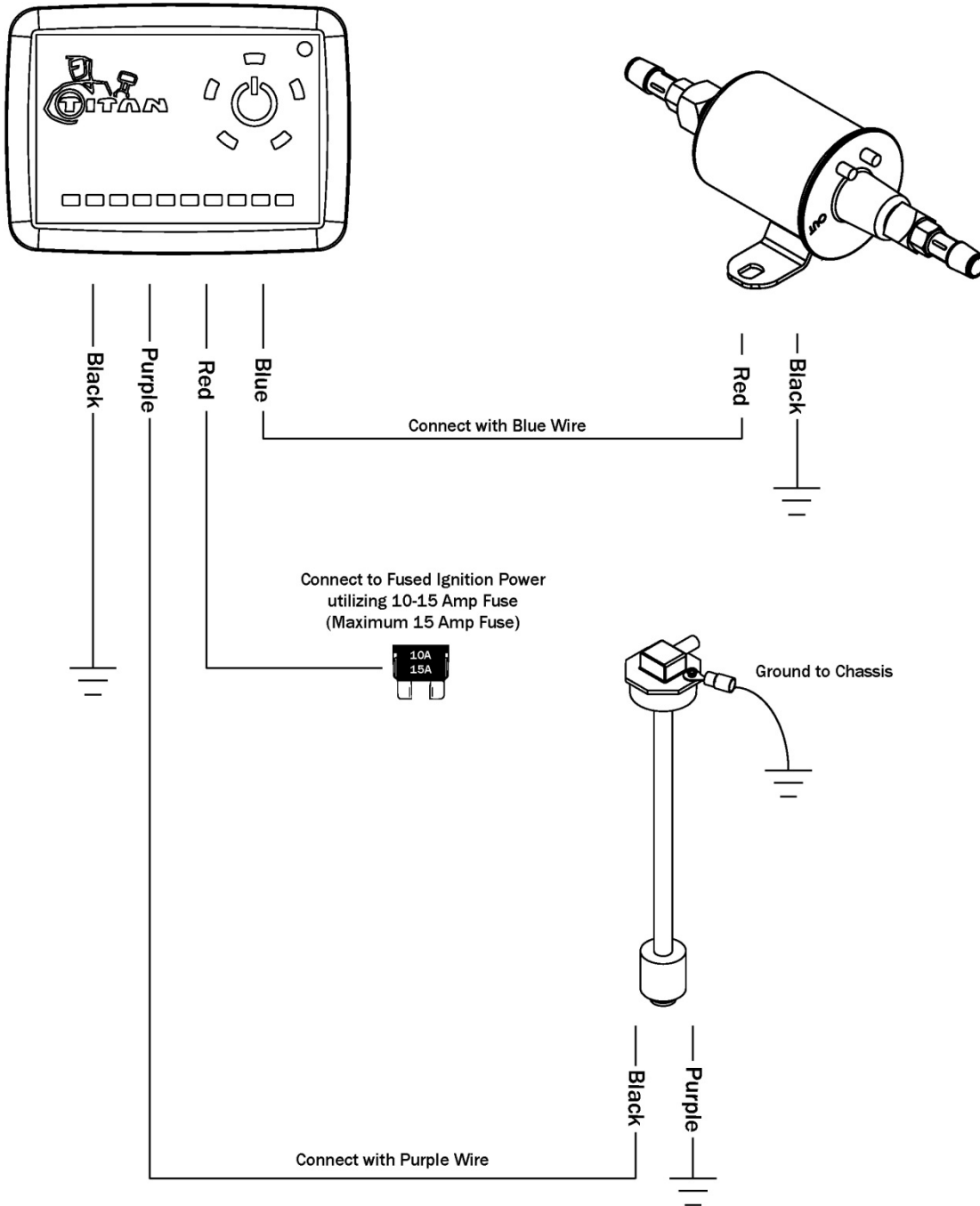

(Fig. 10) TITAN™ Electronic Controller, pump, and sensor wiring diagram.

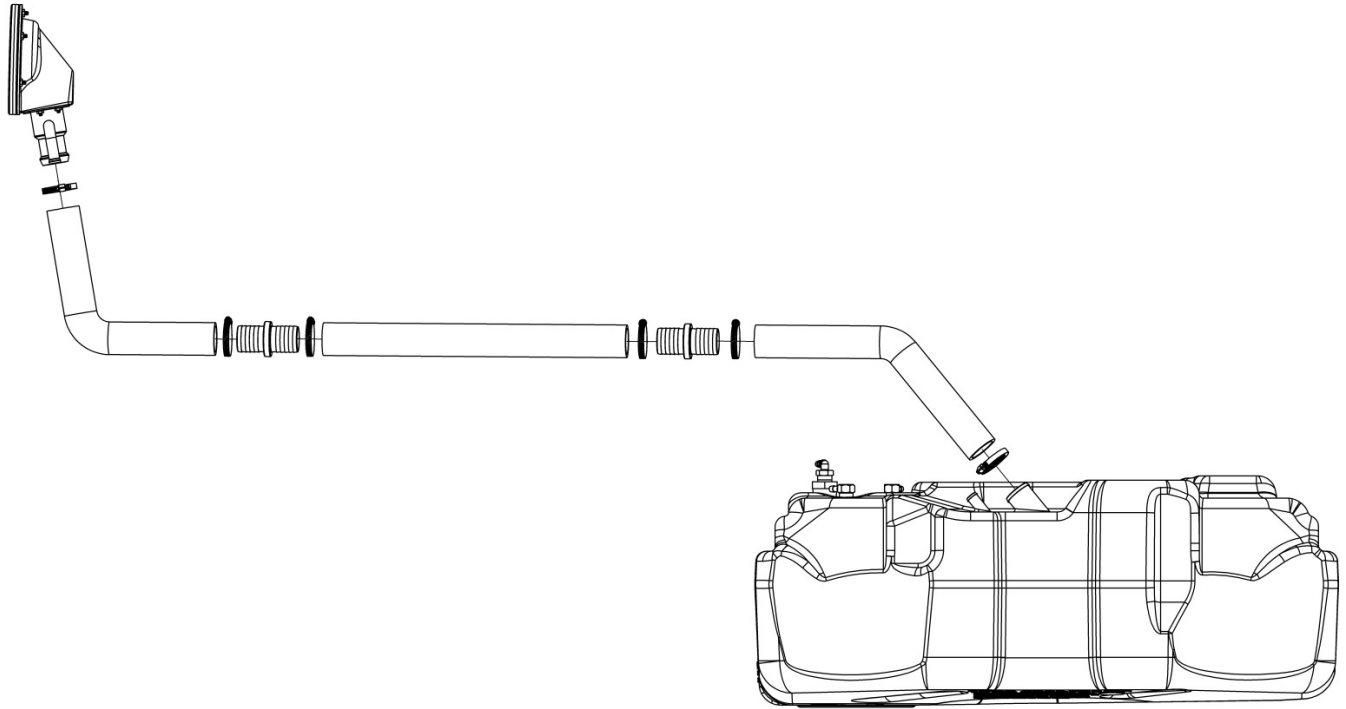

(Fig. 11) Exploded view of the rear of the STAFS tank (side of tank nearest the rear bumper) showing the fill hose plumbing schematic. A 5/8" vent hose running from the vent barb on the tank to the barb on the Poly Filler Neck Flange Assembly is not shown in this view.



(Fig. 12) Using appropriate tools, bend or trim any sharp edges that come in contact with, or obstruct hoses.



(Fig. 13) Using a hammer to bend sheet metal edge out of the way.

- 13 After trimming sharp edges and obstacles from hose path, the tank is ready for permanent installation. Before permanently installing tank, run 3/8" vent line from elbow (See Step 7) and 5/16" hose from rollover valve over top of frame to the vehicle's Original Equipment Manufacture's (OEM) filler neck.
- 14 Install the tank as before. This time tighten the nuts to the torque specifications shown in Fig. 4, that is tighten the nuts at the top Truck Mounting Plate to **45 ft.**

lbs, the flanged nut on the underside of the Tank Mounting Plate to **15 ft. lbs** and the jam nut (“Thin Hex Nut”) at the very bottom to **45 ft. lbs**.

- 15 In the 3/8” hose line, mount pump, using drilling screws and filter and fasten in a convenient location, preferably in a somewhat sheltered place out of the path of water and ice. Be sure the inline filter is located before the suction side of the fuel pump. Filter needs to be accessible for service (See Fig. 14).



(Fig. 14) Fuel pump and inline filter installed.

- 16 Using the supplied ring terminal, ground black fuel pump wire to chassis member using supplied, extra 30” wire, if needed. Attach red power wire on pump to blue 20 ft. wire provided, using supplied heat-shrink butt terminals. Cover with plastic loom. Run wire loom with blue and purple (from Electric Fuel Sensor) wire along frame rail to cab access. Refer to Fig. 10, wiring diagram.
- 17 Cut vent line from vehicle’s OEM fill neck, and install Vent Fill Neck Adapter (99 0000 0409). The small diameter tubing of the adapter should be closest to vehicle’s fill cap.



(Fig. 15) Vent Fill Neck Adapter installed.



(Fig. 16) Fuel Door located in outside fender.

- 18 Connect 3/8" line from pump to largest tubing on Vent Fill Neck Adapter. The 5/16" hose from tank body rollover valve goes to the other one. Use hose clamps on all connections.

IV. Install Filler Neck Kit

- 19 Determine desired location of Fuel Door. Door (See Fig. 16) can be installed in outside of fender OR on the inside wall of the bed wall (See Fig. 17). Check to be sure there is sufficient clearance available in the proposed location for the Poly Filler Neck Flange Assembly (See Fig.18).

When mounting on the outside of the fender, it is generally most attractive if the horizontal center of the TITAN™ Fuel Door is aligned with the horizontal center of the OEM fuel door. If necessary, run masking tape horizontally from the front fuel door to the back to align the centers. If aesthetics is NOT a concern, be aware the tank will fill best when the fuel door is located as high as possible.

NOTE: If mounting inside the vehicle's bed wall, the best location is shown in Fig. 17.



(Fig. 17) Location of Fuel Door located inside of bed wall.



(Fig. 18) Check to be sure there is room in the fender space for the Poly Fuel Neck Flange Assembly BEFORE cutting any holes. Always test fit FIRST. Some fender spaces may require the trimming of sheet metal components to allow proper fit.

- 20 After carefully determining the location for the fuel door, cut a hole in the side of the fender, or the bed wall using 4.75" hole saw (See Fig. 19).



(Fig. 19) Use 4.75" hole saw to cut hole for Fuel Door.



(Fig. 20) Cut out appropriate template and tape it around the 4.75" hole. Use center punch to mark screw positions and then using appropriate drill bit size, drill marked holes.

**TITAN™ Installation Template
for 6-1/2" OD Fuel Door**

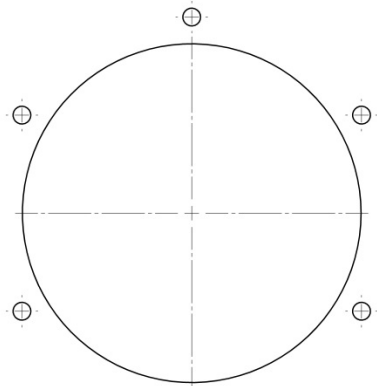

PN: 99 0000 0480



(Fig. 21) Facsimile of template supplied for Fuel Door installation in outside of fender or inside bed wall.

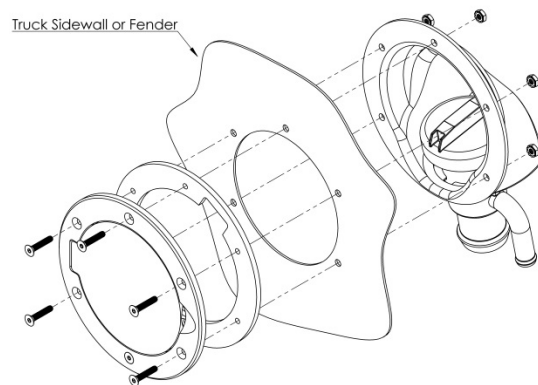

(Fig. 22) Exploded view of Fuel Door and Filler Neck showing assembly on installation.

21 Center and tape the provided Fuel Door Installation Template over the large hole which has been cut in the vehicle and mark the five screw locations with a center punch. Using a 1/4" drill bit, drill out the five screw holes (See Fig. 20).

- 22 Assemble and install Fuel Door and Filler Neck Assembly as shown in Fig. 22.
- 23 Assemble fuel fill line as per view in Fig. 11. Trim the molded hoses as needed to fit the installation. Be sure there are no “sags” in the hose and that it is angled downhill towards the tank. Install 5/8” vent line also making sure it does not “sag” anywhere.
- 24 Recheck all bolts, screws and hose clamps to be sure they are all tight and secure.
- 25 Reinstall rear bumper and lower vehicle to the ground.
- 26 Mount the TITAN™ Electronic Controller in a convenient location in the cab drilling a 3/8” hole and using the supplied Velcro to hold it.
- 27 Complete wiring as per diagram in Fig. 10. Utilize ATM Fuse Tap and Barrel Quick Disconnect Terminal to wire into vehicle’s fuse block utilizing a 10-15 Amp (maximum 15 Amp) fuse.
- 28 **VERY IMPORTANT:** Using filling station pump, completely fill the STAFS tank with diesel fuel. Check for leaks, and the operation of the Electronic Controller (See Fig. 23). This is a critical step as there is no warranty on the system unless it is filled and tested upon installation.

TITAN™ Electronic Controller

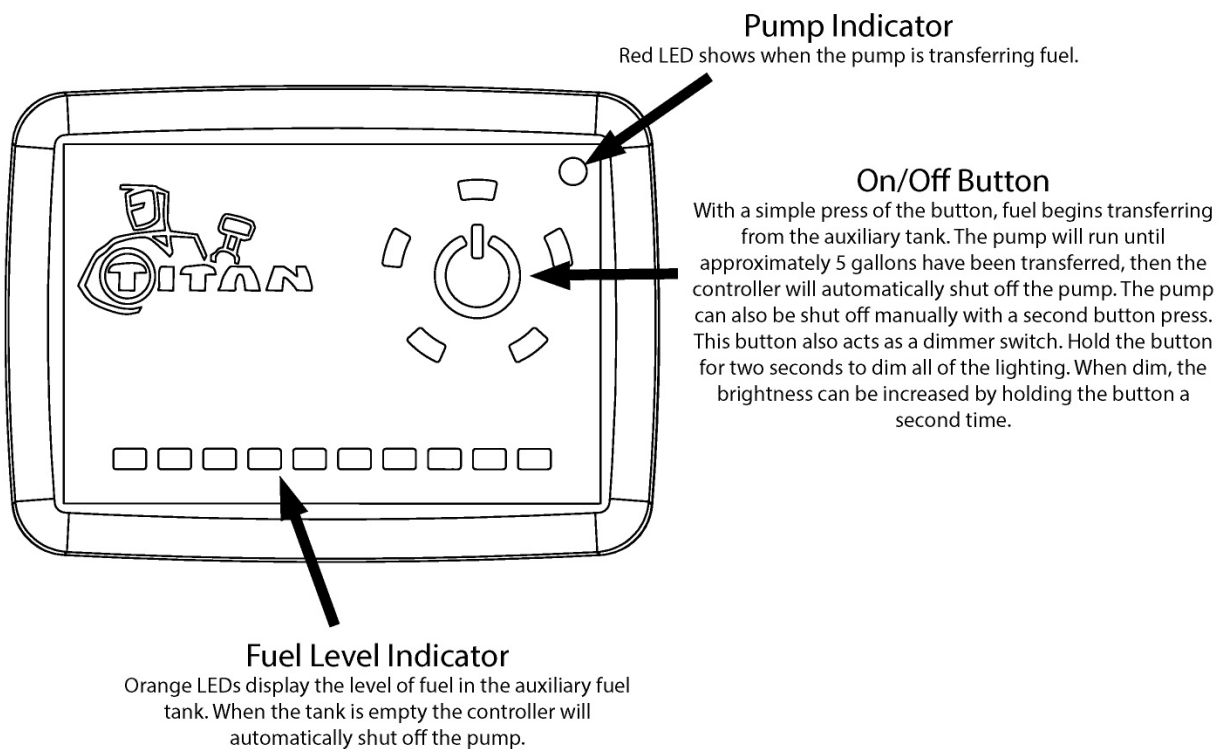

(Fig. 23) Operation instructions for TITAN™ Electronic Fuel Controller.



Installation Complete!

* All capacities are approximate

++ Patent Pending

Be sure to return the completed warranty registration for your new Titan™ fuel tank; or you can register on-line at www.titanfueltanks.com

Write your tank's Serial Number here: _____

A tank must be registered within sixty (60) days of receipt for the warranty to be valid.

Warranty is void if product is improperly installed.

For questions or customer service call (800) 728-4982



**P.O. Box 2225
Idaho Falls, ID 83403 USA
Telephone (800) 728-4982 FAX (208) 529-2162**

www.titanfuel tanks.com

TITAN Fuel Tanks™ are PROUDLY MADE IN THE USA

Revised 11.13.13

©2013 Supertanks, LLC

All Rights Reserved.